

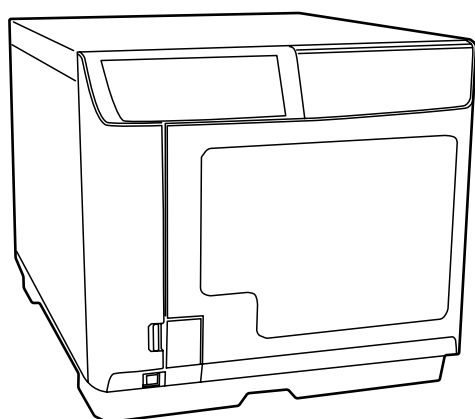

Total Disc Maker

Read Back Function/Merge Function Configuration Guide

About this Guide.....	2
Read Back Function (for the PP-100III/PP-100II/PP-50II/PP-50BD only).....	3
Merge Function.....	6
Appendix.....	23



About this Guide

This guide explains how to configure the Read Back function and the Merge function in Total Disc Maker and Total Disc Setup. For more information, please refer to Help in EPSON Total Disc Maker.

Symbols Used in this Guide

The following symbol is used in this guide to draw attention to important information.

NOTE

Indicates supplementary explanations or additional information the user should know.

Screens Appearing in this Guide

The Windows screens that appear in this guide are from Windows 10, unless specified otherwise.

Supported Versions

The Read Back function and the Merge function are supported by EPSON Total Disc Maker version 5.00 or later.

Read Back Function (for the PP-100III/PP-100II/PP-50II/PP-50BD only)

With the Read Back function, you can copy data (duplicate files or save disc images) from multiple discs set in the stacker to the specified folder with a single operation.

For more information about this function, please refer to Help in EPSON Total Disc Maker.

[Help] - [Operation Mode (Read Back)] - [Reading and Saving Files From Discs]

[Help] - [Operation Mode (Read Back)] - [Creating Disc Image from Data Disc in a Single Operation]

Configuration Procedure

1. Set the disc that contains the data files that you want to read back in the stacker.
2. Start Total Disc Setup. Right-click the printer in which you set the disc in procedure 1, and then click [Properties] in the pop-up menu.

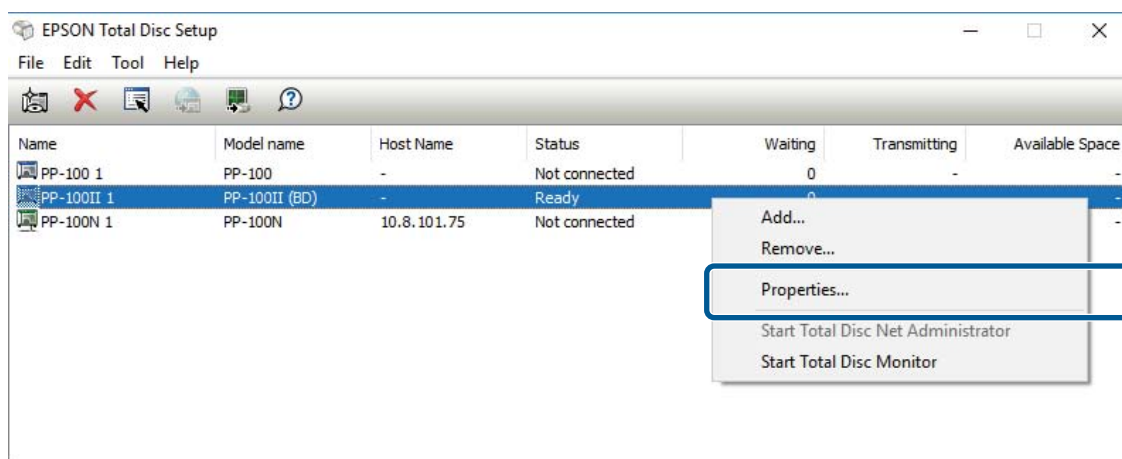

3. On the [General] tab, select [Read Back mode] for [Publish Mode], and then click the [OK] button.

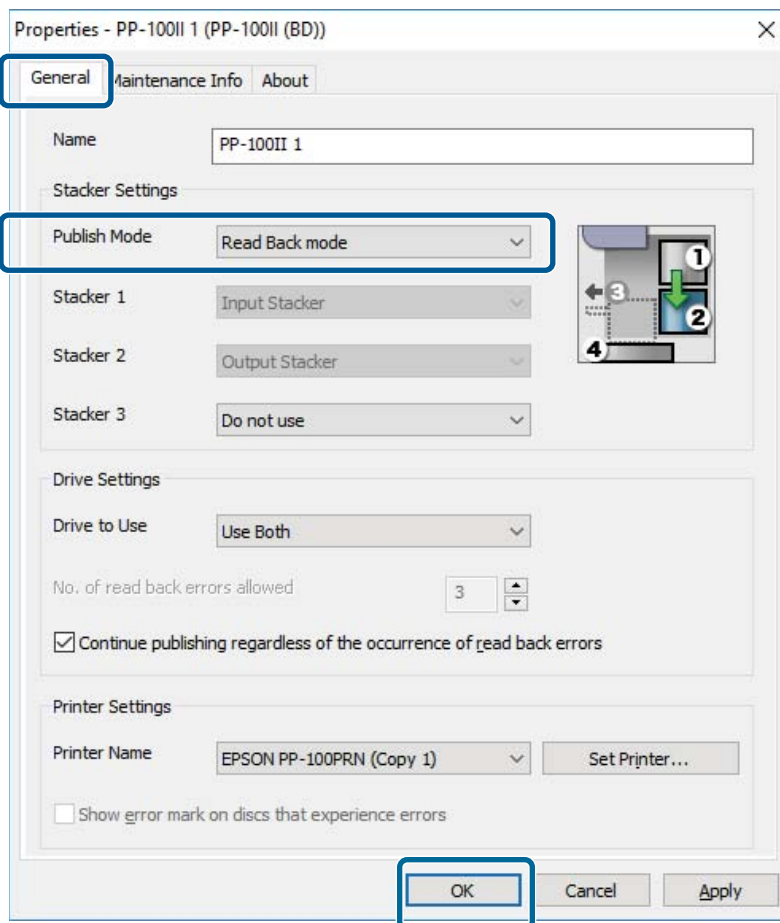

4. Start Total Disc Maker.

On the [Type] tab in Disc view, select [Read Back] and then click the [Apply] button.

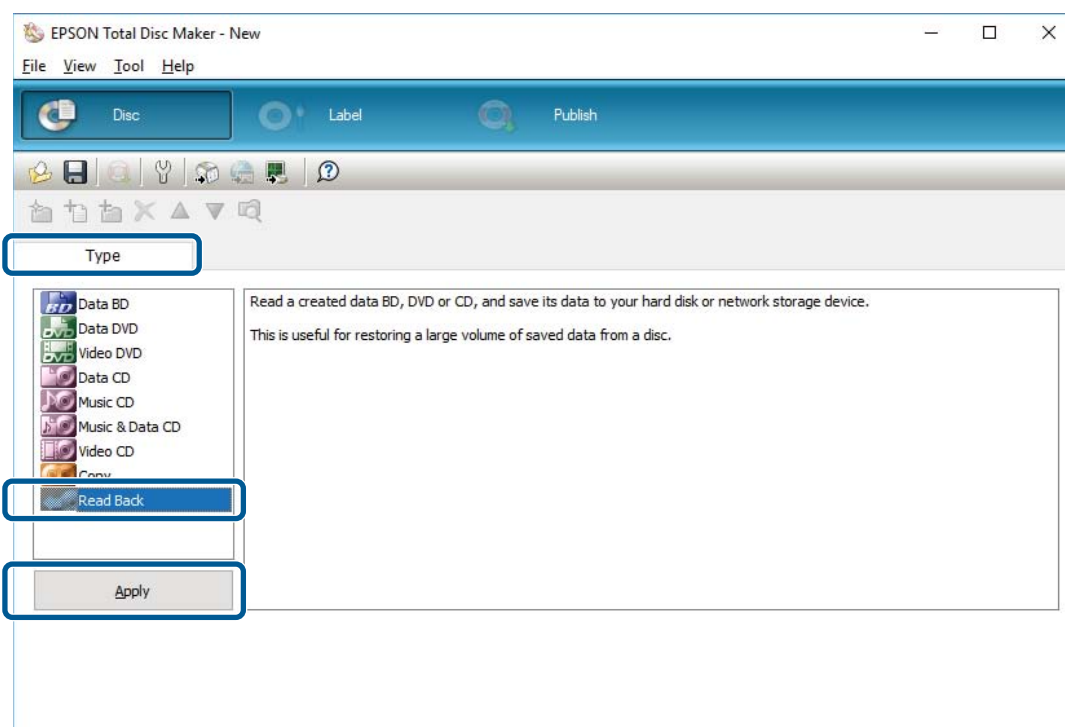

Merge Function

With the Merge function, you can create a CSV file to specify the information to be printed and the data to be written to disc, for each disc.

For more information about CSV files, see [CSV Files on Page 7](#).

There are 3 different uses for this function. For more information, please refer to Help in EPSON Total Disc Maker.

[Help] - [Operation Mode (Creating a Label)] - [Editing Items] - [Merge (print label)]

[Help] - [Operation Mode (Creating a Disc)] - [Creating Data Discs] - [Merge Function (data file)]

[Help] - [Operation Mode (Creating a Disc)] - [Copying a CD/DVD/BD] - [Merge Function (disc image)]

Use 1: Merge Function (print label)

Print different numbers and barcodes on discs.

For more information about the configuration procedure, refer to [Merge Function \(print label\) on Page 8](#).

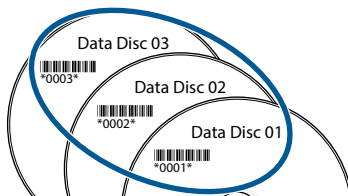

Use 2: Merge Function (data file)

Write different data to each disc.

For more information about the configuration procedure, refer to [Merge Function \(data file\) on Page 13](#).

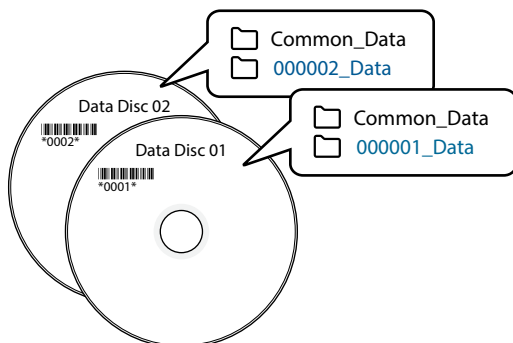

Use 3: Merge Function (disc image)

Write different disc image files to each disc at the same time.

For more information about the configuration procedure, refer to [Merge Function \(disc image\) on Page 18](#).

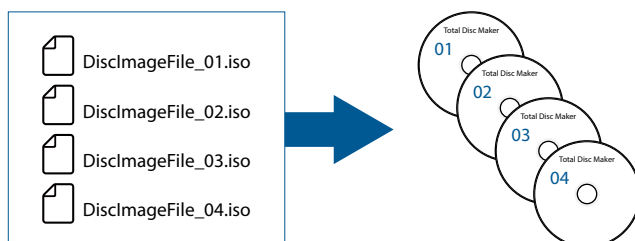

Limitations

The Merge function has the following limitations.

Number of Discs that can be Printed at a Time

Up to 100 discs can be printed at a time with the Merge function.

Number of Items that can be Created in a Label

The following table shows the number of items that can be created in single label.

Item	Item name	Limitation
Maximum number of characters	Text	1,024 characters (2,048 bytes)
Maximum number of items	Thumbnails	10
	Images	50
	All items	255 in total

Types of Items Supported by the Merge Function

The Merge function supports text and barcodes.

CSV Files

Samples of CSV files that you can use with the Merge function are available in the following folder.

EPSON Total Disc Maker installation folder (default setting):

32-bit OS C:\Program Files\epson\Total Disc Maker\sample

64-bit OS C:\Program Files (x86)\epson\Total Disc Maker\sample

No	Title	Subtitle	Coaching/Mentoring Provider	Host Location	Date	Files
3	121002 Coaching and Consultation	Risk Management - Why and How	ABCD Workshops, Inc.	ABCD Training Center, CA	10/1/2012	d:\data\121002
4	121003 Coaching and Consultation	Coaching Vs. Mentoring	ABCD Workshops, Inc.	ABCD Training Center, CA	10/2/2012	d:\data\121003
5	121004 Coaching and Consultation	Building Blocks of an Effective Team	ABCD Workshops, Inc.	ABCD Training Center, CA	10/2/2012	d:\data\121004
6	121005 Coaching and Consultation				10/3/2012	d:\data\121005
7	121006 Coaching and Consultation				10/3/2012	d:\data\121006
8	121007 Coaching and Consultation	The Golden Rule to Effective Leadership	ABCD Workshops, Inc.	ABCD Training Center, CA	10/4/2012	d:\data\121007
9	121008 Coaching and Consultation	Leadership Vs. Management 101	ABCD Workshops, Inc.	ABCD Training Center, CA	10/4/2012	d:\data\121008
10	121009 Coaching and Consultation	The Secret to Effective Meetings	ABCD Workshops, Inc.	ABCD New York Center	10/4/2012	d:\data\121009
11	121010 Coaching and Consultation	Time Management for Coaches	ABCD Workshops, Inc.	ABCD New York Center	10/4/2012	d:\data\121010

The following table shows the limitations regarding the CSV files that can be used.

Item	Limitation
1st row	Must display column names
Maximum number of rows*	101
Maximum number of columns*	257

*: Data in a CSV file that exceeds the maximum number of rows or maximum number of columns is not read.
Column names are included in the maximum number of rows.

Merge Function (print label)

1. Create a CSV file that includes the information you want to merge.

 [CSV Files on Page 7](#)

2. Start Total Disc Maker.

Select Label view and then click the [Edit Item] tab.

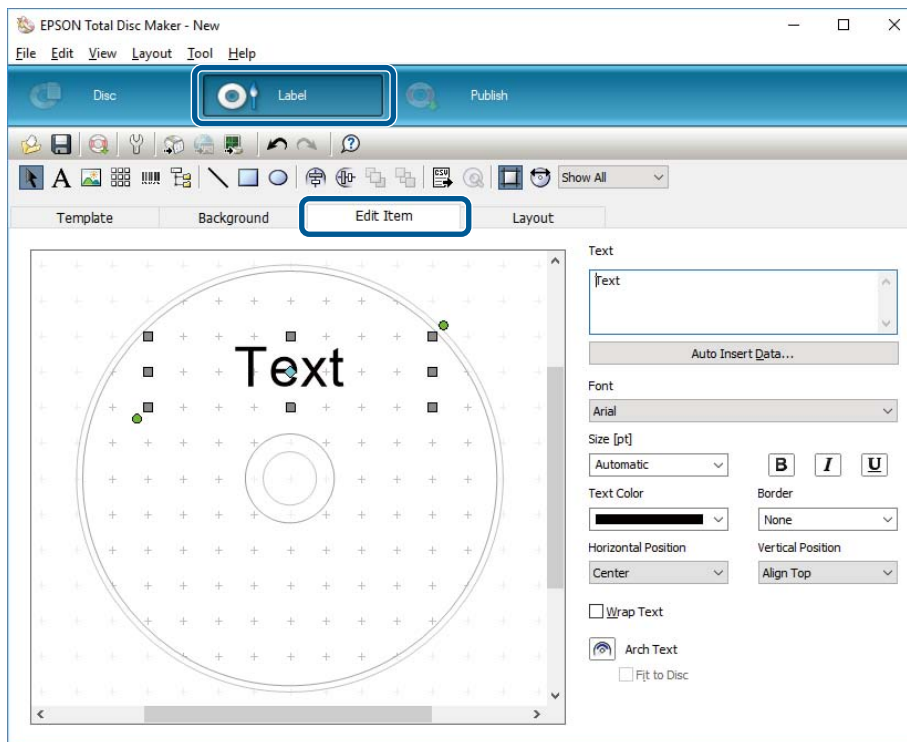

3. Click  [Text] in the tool bar, and then click the location where you want to place the merged text. The text item appears in the edit area.

To merge a barcode item, click  [Barcode].

- Click the [Auto Insert Data...] button. The Auto Insert Data screen appears.

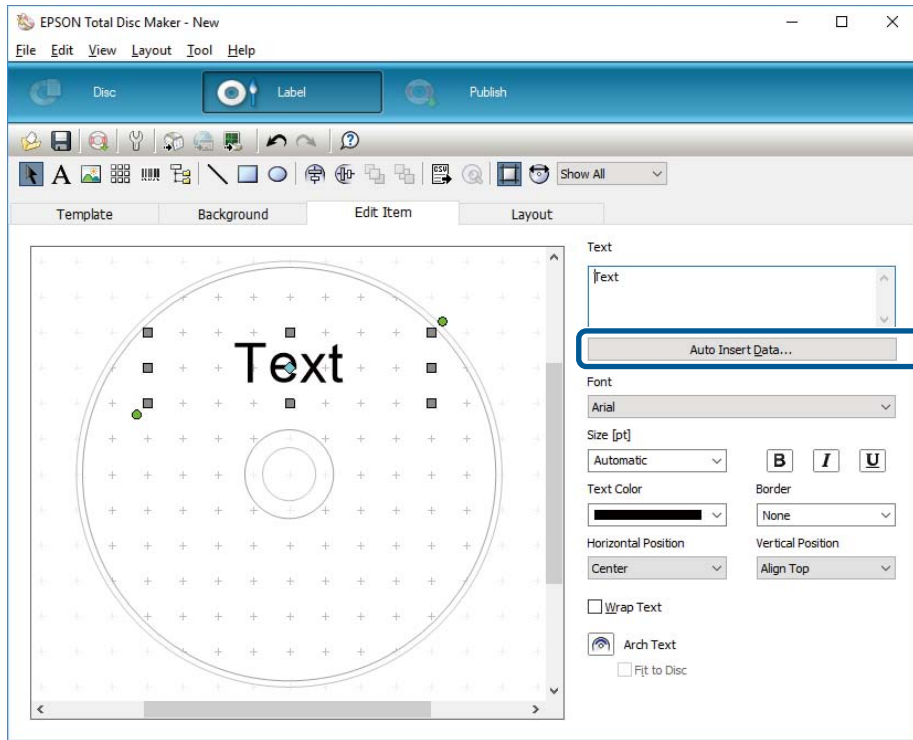

- In the Auto Data list select [Merge Print], and then click the [Specify CSV file] button. The Manage Merge Data screen appears.

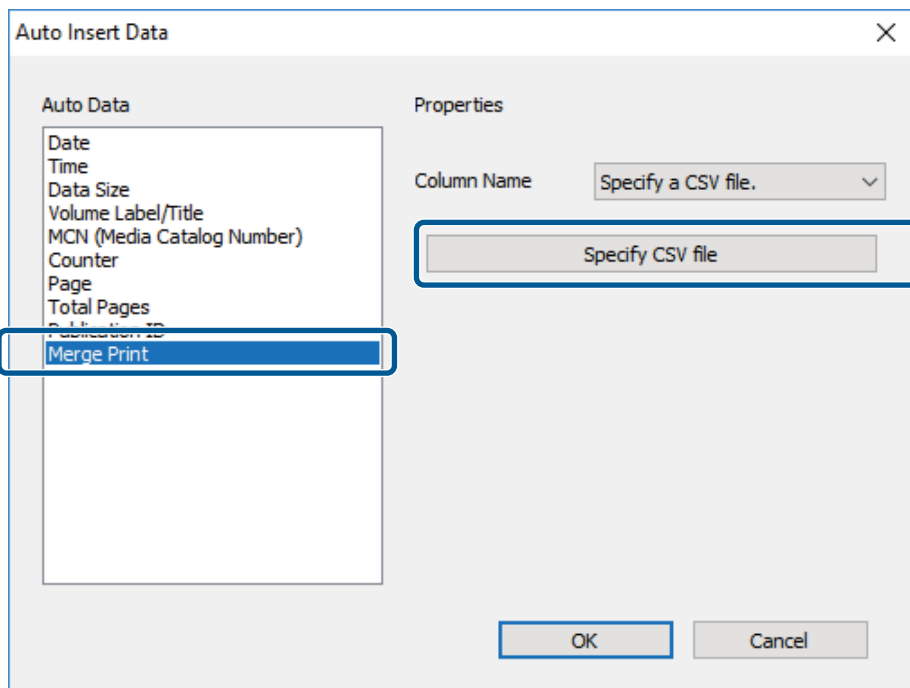

6. Click the [Browse] button, and then select the CSV file that you created in procedure 1. Select the check boxes for the rows that you want to publish, and then click the [OK] button.

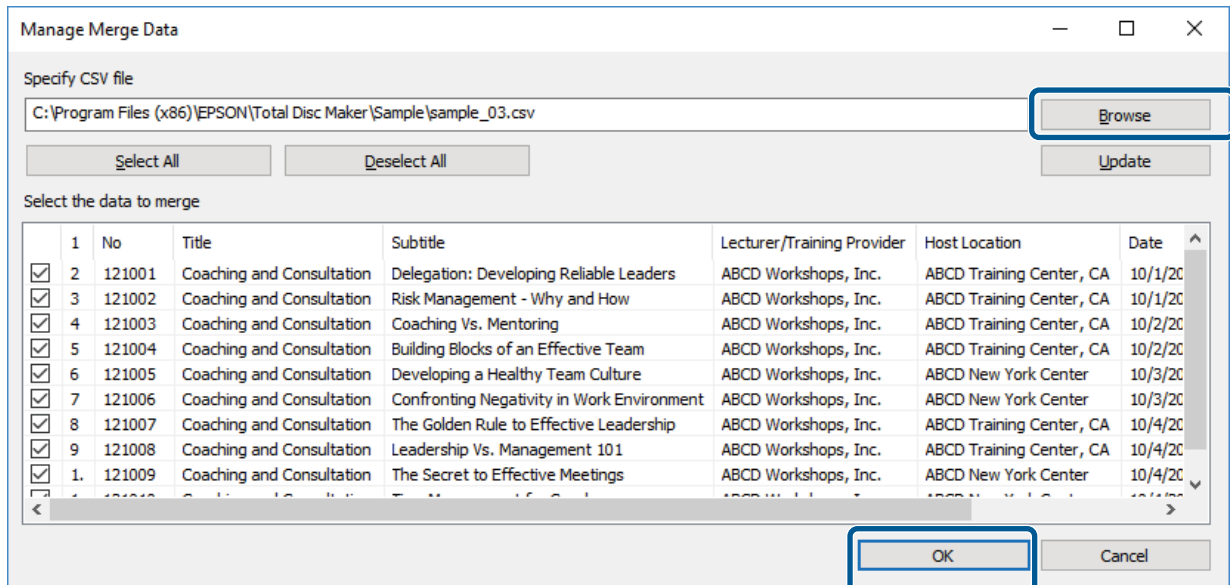

7. Use [Column Name] to select the column name that you want to merge in the text item, and then click the [OK] button.

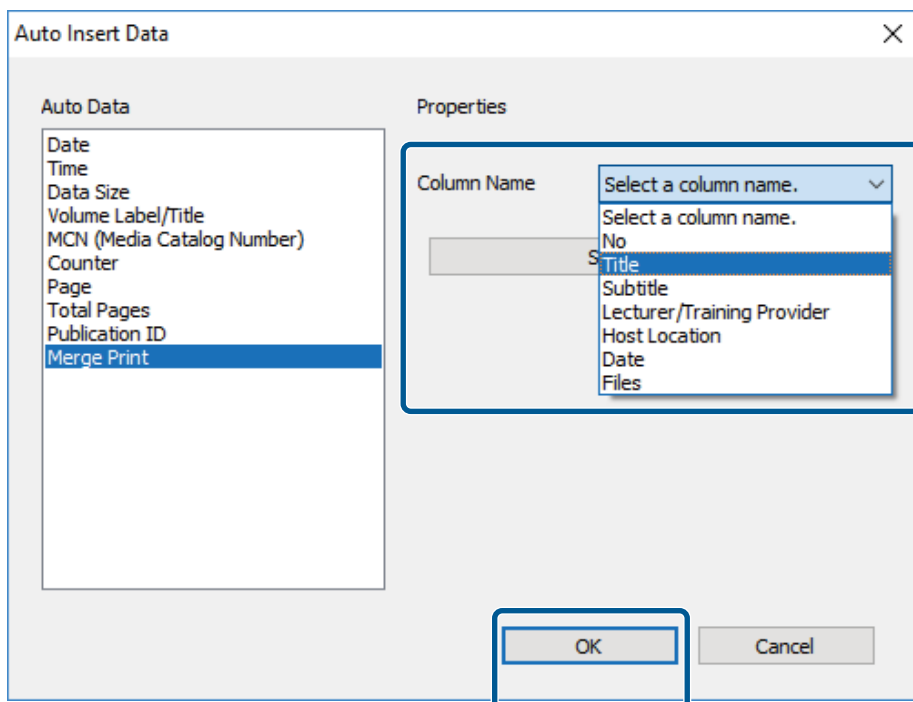

8. When the format check is finished, click the [OK] button.

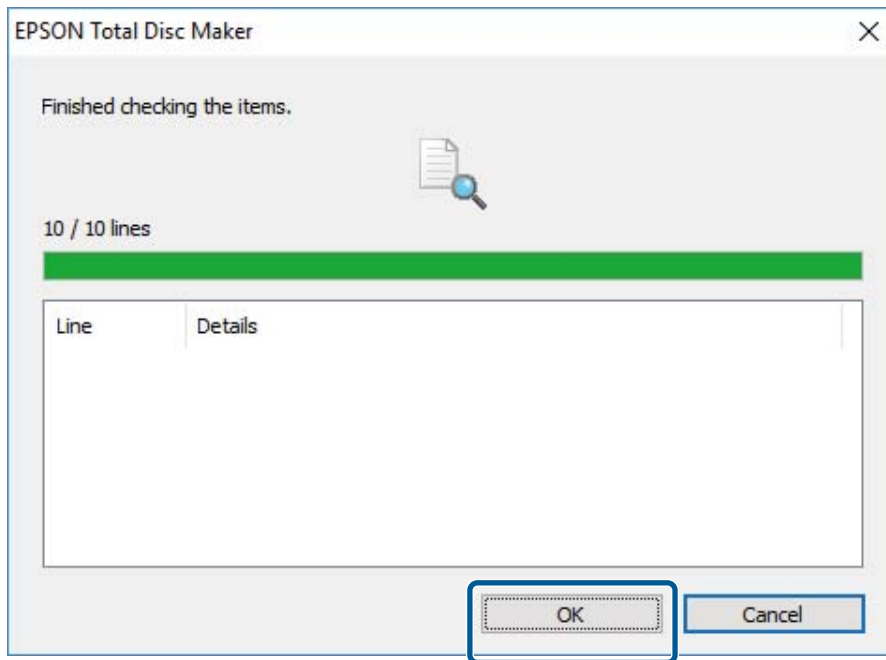
**NOTE**

- If an error is found, click the [Cancel] button and correct the CSV file.
- To read a corrected CSV file, click the [Update] button on the Manage Merge Data screen.

9. Confirm that the data for the selected column name has been merged in the text item.
To continue merging the content of other columns, repeat procedures 7 through 9.

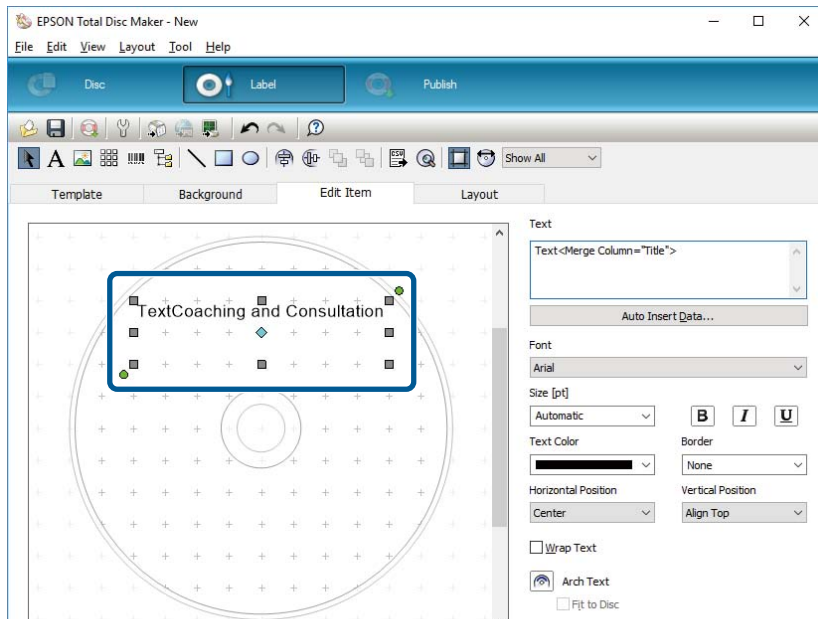

NOTE

- Only the data that will be printed on the label for the 1st disc will appear in the edit area.
- For more information about how to publish a disc, please refer to the User's Guide for the product you are using.

This completes the procedure for configuring the Merge function (print label).

Merge Function (data file)

1. Create a CSV file that specifies the full path to the folder where the merged data will be saved.

 [CSV Files on Page 7](#)

You can specify one folder for each disc.

2. Start Total Disc Maker.

On the [Type] tab in Disc view, select either [Data BD], [Data DVD], or [Data CD] and then click the [Apply] button.

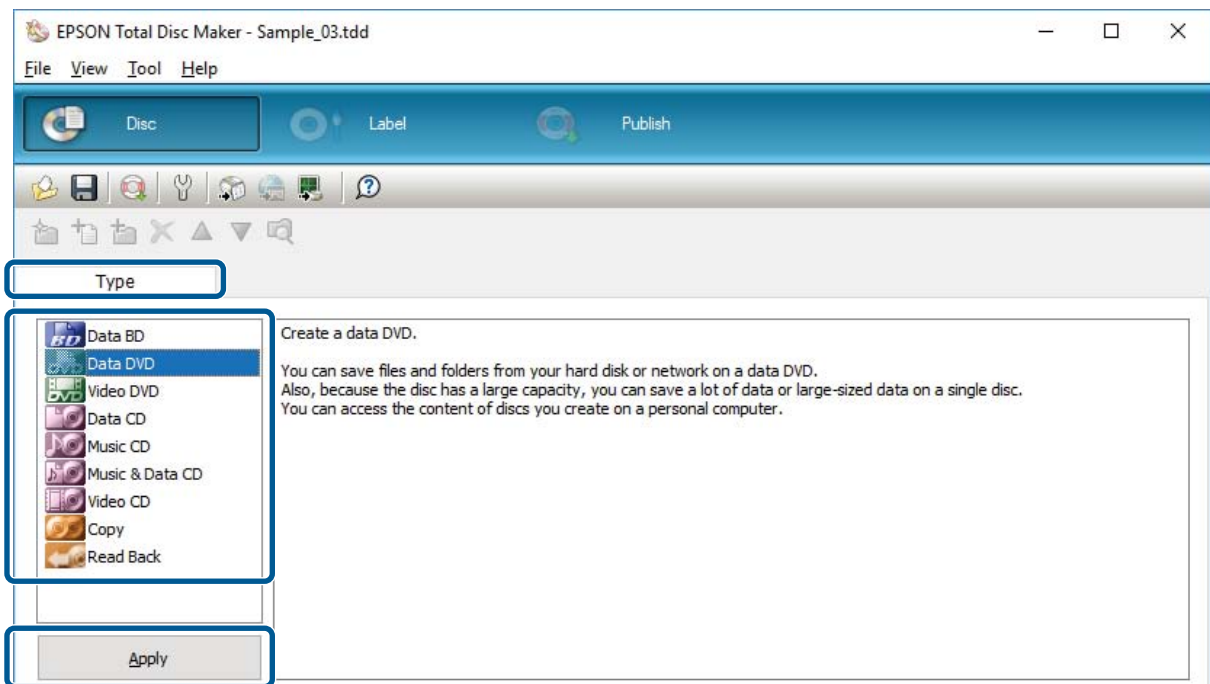

3. On the [Edit Data] tab, click the [Auto Insert Data...] button.
The Auto Insert Data screen appears.

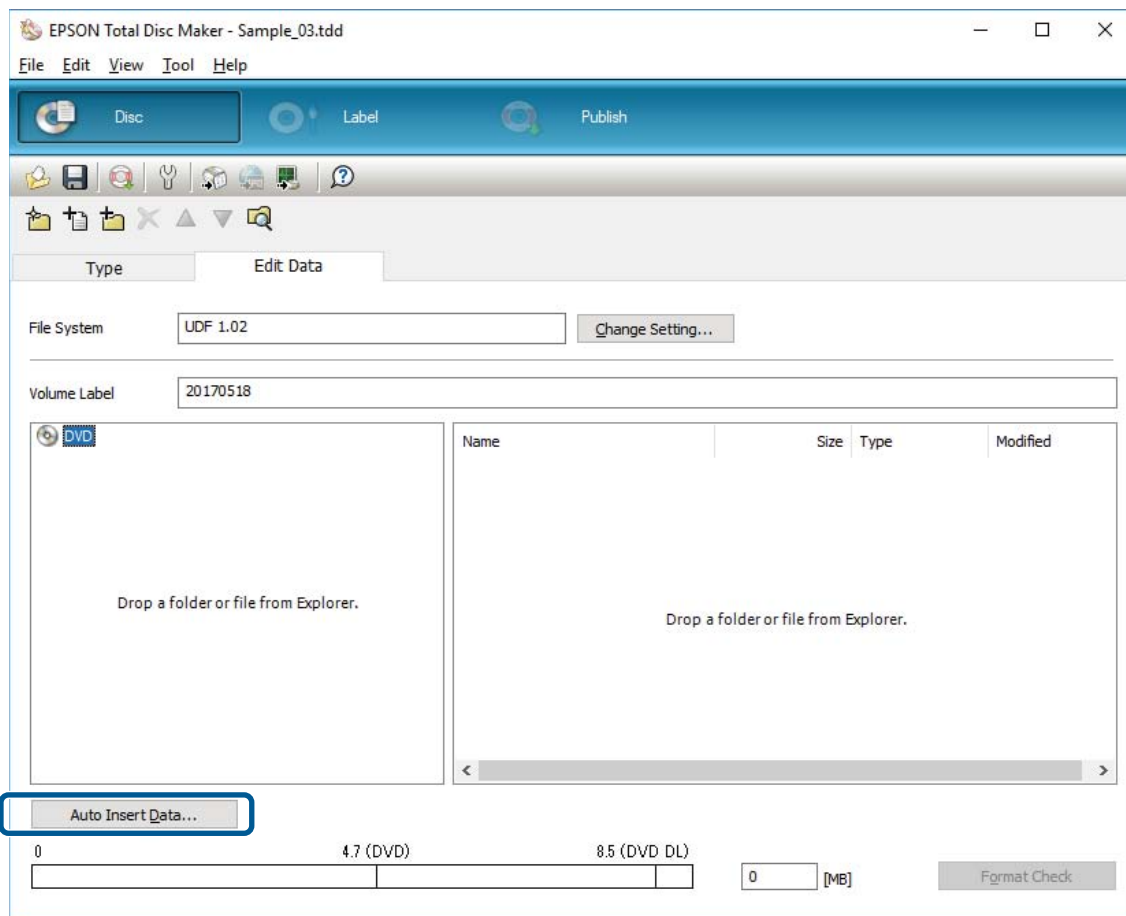

4. Click the [Specify CSV file] button.
The Manage Merge Data screen appears.

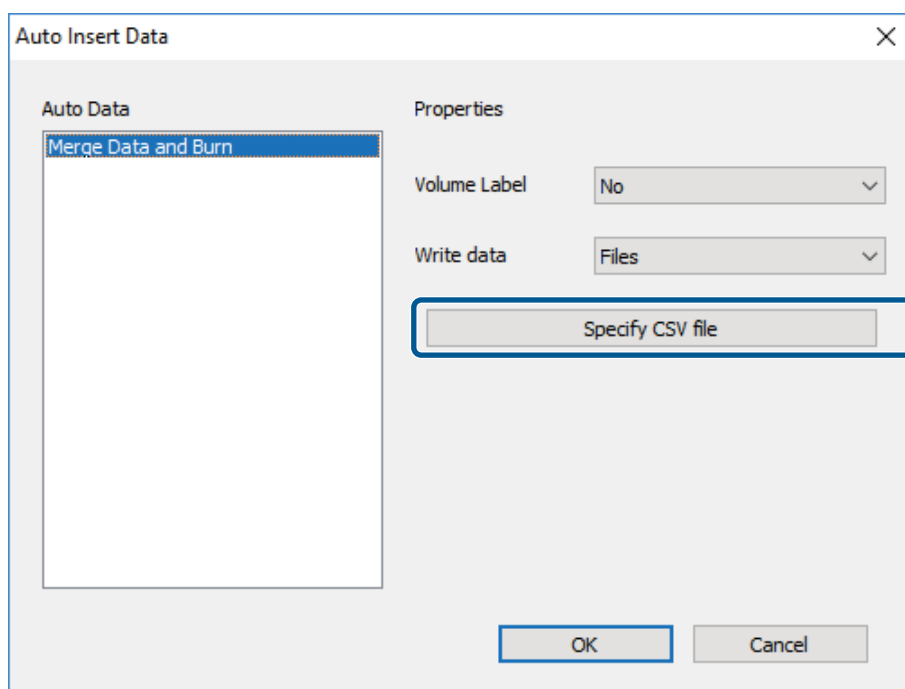

- Click the [Browse] button, and then select the CSV file that you created in procedure 1. Select the check boxes for the rows that you want to publish, and then click the [OK] button.

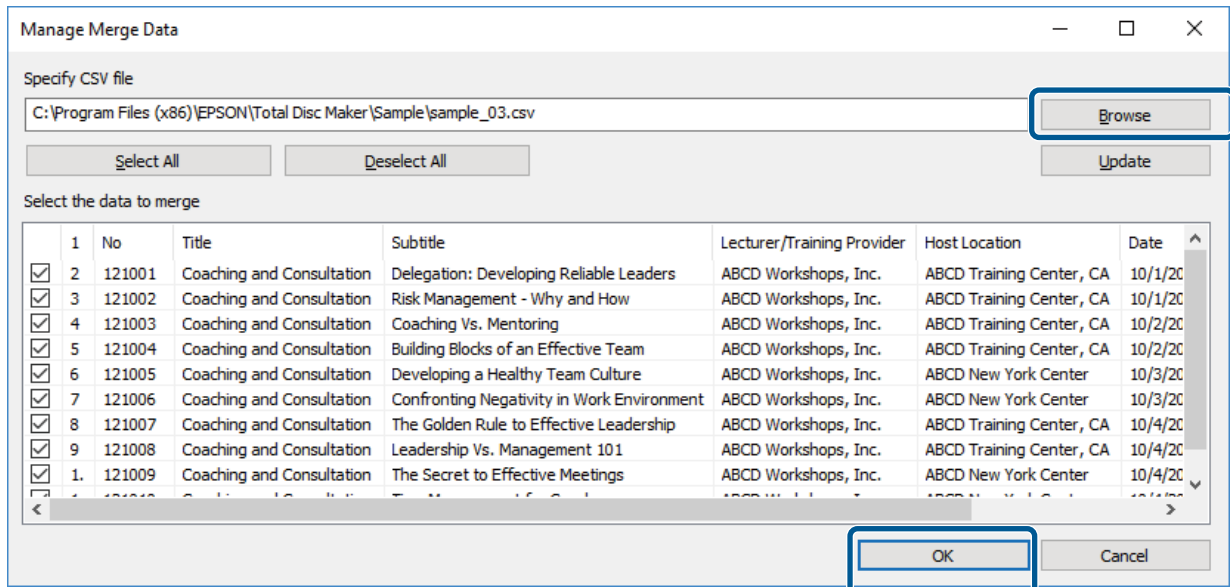

- For [Volume Label] select the column name that has the volume label for the data file that you want to merge, and for [Write data] select the column name that has the full path, and then click the [OK] button.

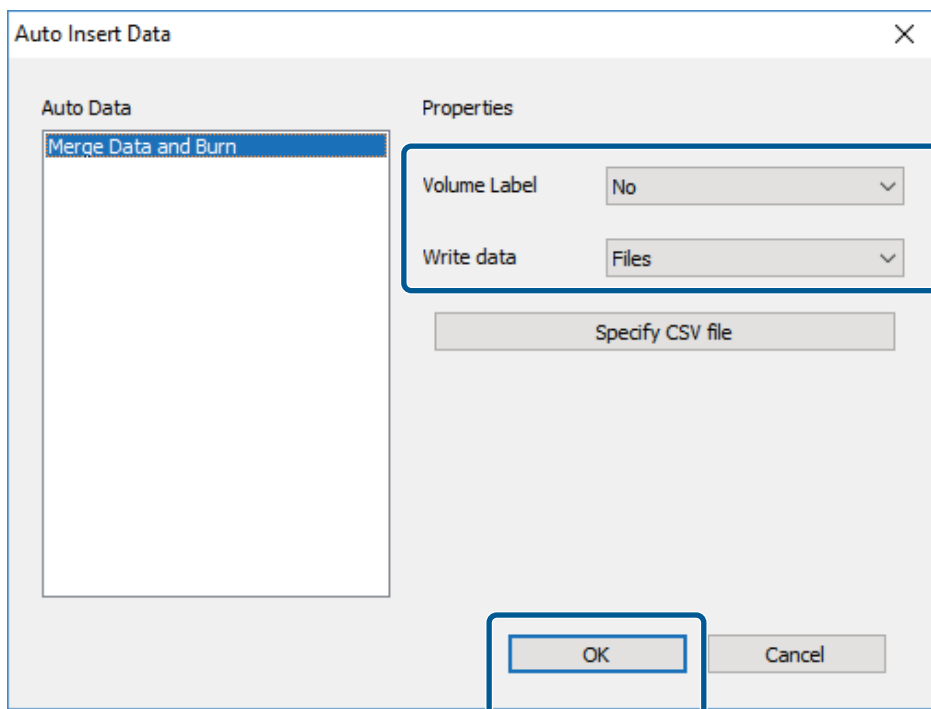

7. When the format check is finished, click the [OK] button.

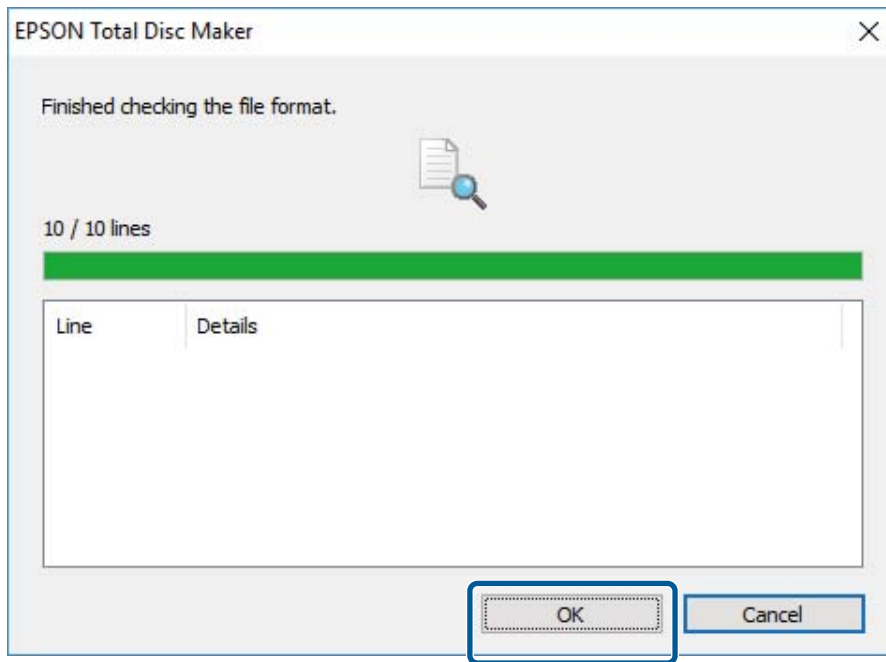
**NOTE**

- If an error is found, click the [Cancel] button and correct the CSV file.
- To read a corrected CSV file, click the [Update] button on the Manage Merge Data screen.

8. Confirm that the data to be written appears on the [Edit Data] tab in Disc view.

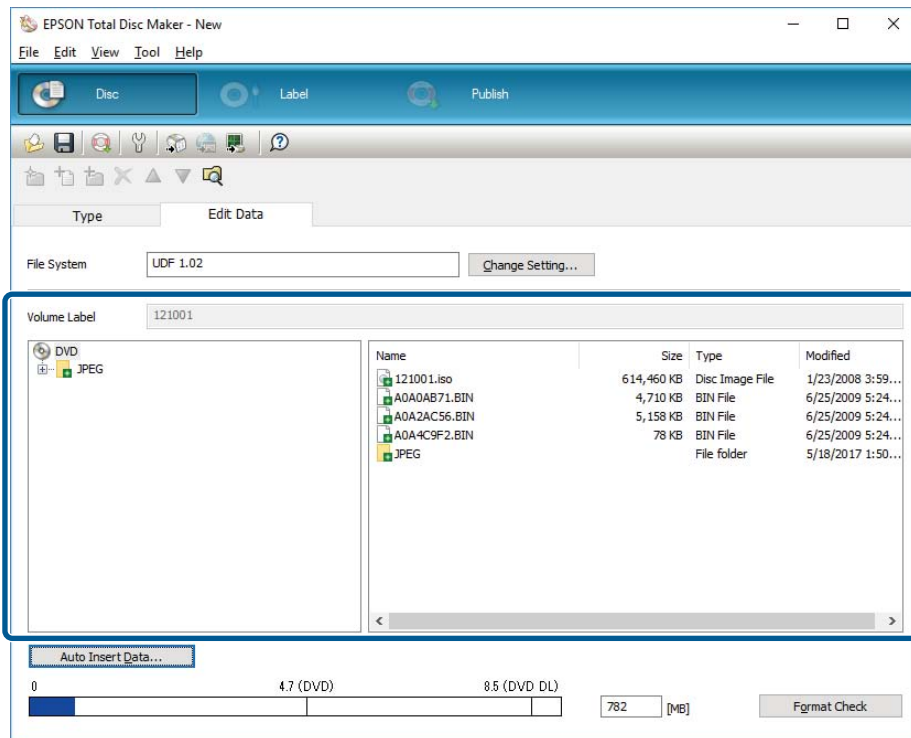

- Only the content that will be written to the 1st disc will appear.

NOTE

- Merged data that has been specified with a CSV file is indicated by .
- For more information about how to publish a disc, please refer to the User's Guide for the product you are using.

This completes the procedure for configuring the Merge function (data file).

Merge Function (disc image)

1. Create a CSV file that specifies the full path to the disc image file that you want to write.

 [CSV Files on Page 7](#)

NOTE

- To create disc image files from multiple discs at the same time, refer to [Read Back Function on Page 3](#).
- The guarantee of operation applies only to disc image files (iso files) created with Total Disc Maker.

2. Start Total Disc Maker.

On the [Type] tab in Disc view, select [Copy] and then click the [Apply] button.

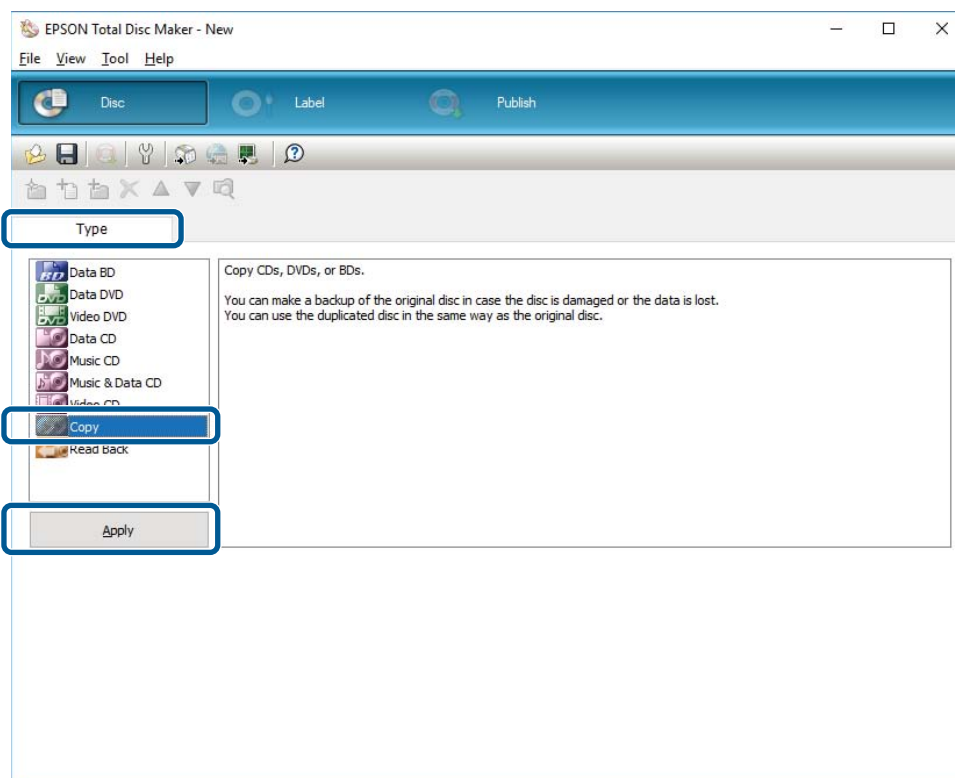

3. On the [Copy] tab, select [Disc Image] and then click the [Auto Insert Data...] button. The Auto Insert Data screen appears.

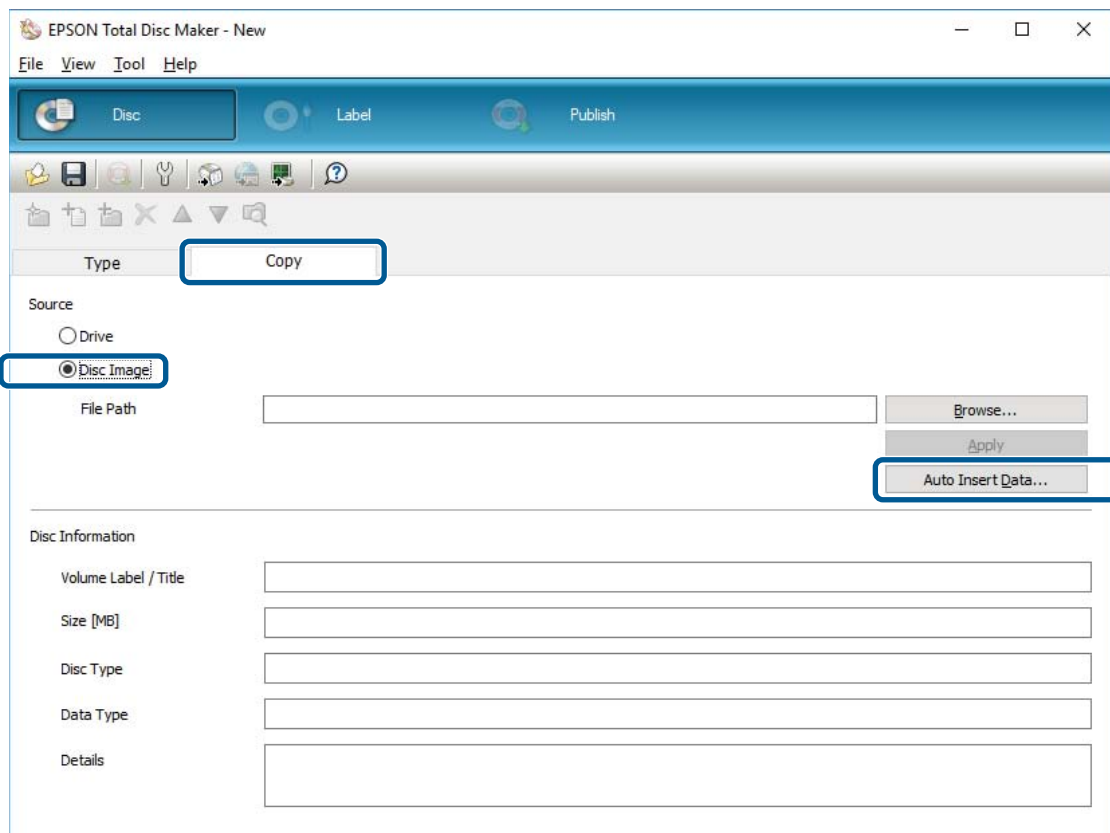

4. Click the [Specify CSV file] button. The Manage Merge Data screen appears.

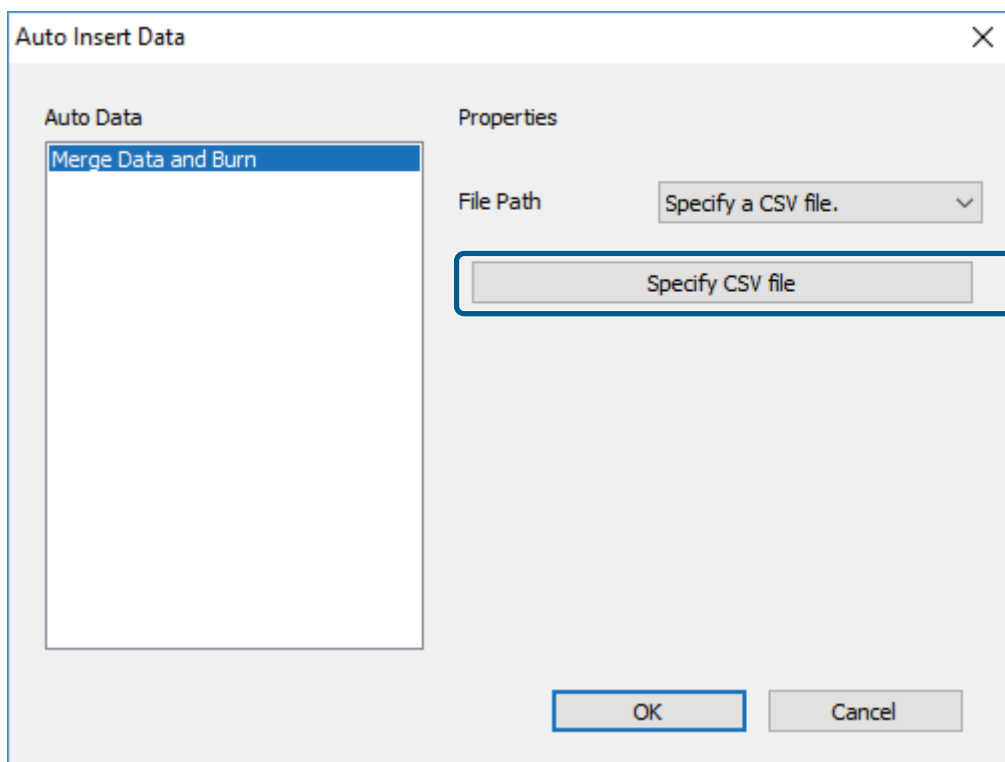

- Click the [Browse] button, and then select the CSV file that you created in procedure 1. Select the check boxes for the rows that you want to publish, and then click the [OK] button.

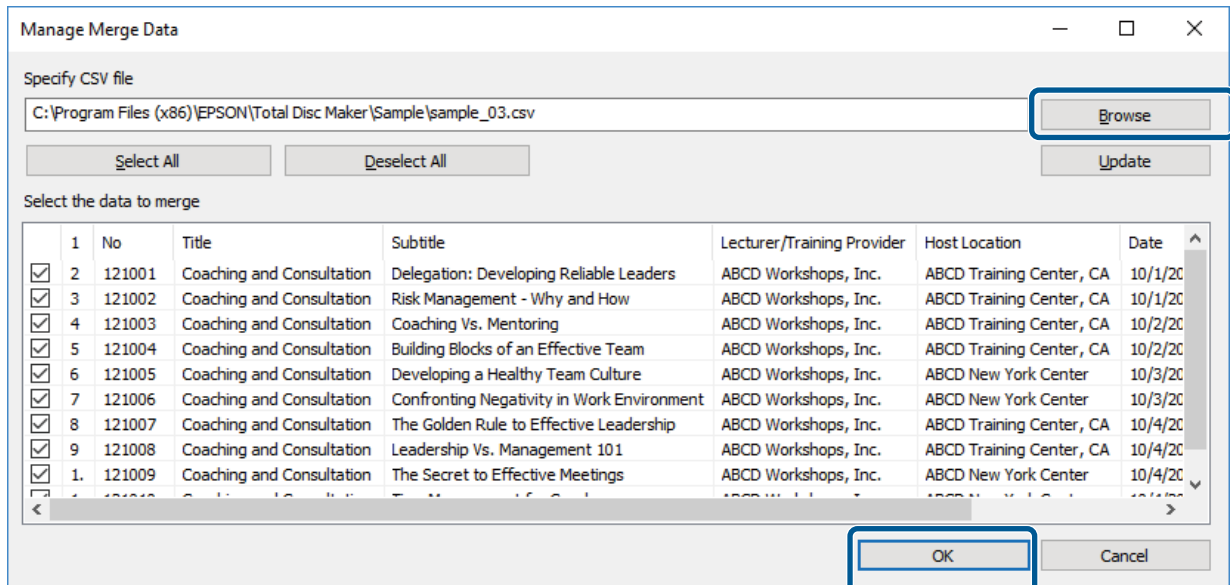

- For [File Path] select the column name that has the full path to the disc image file that you want to write, and then click the [OK] button.

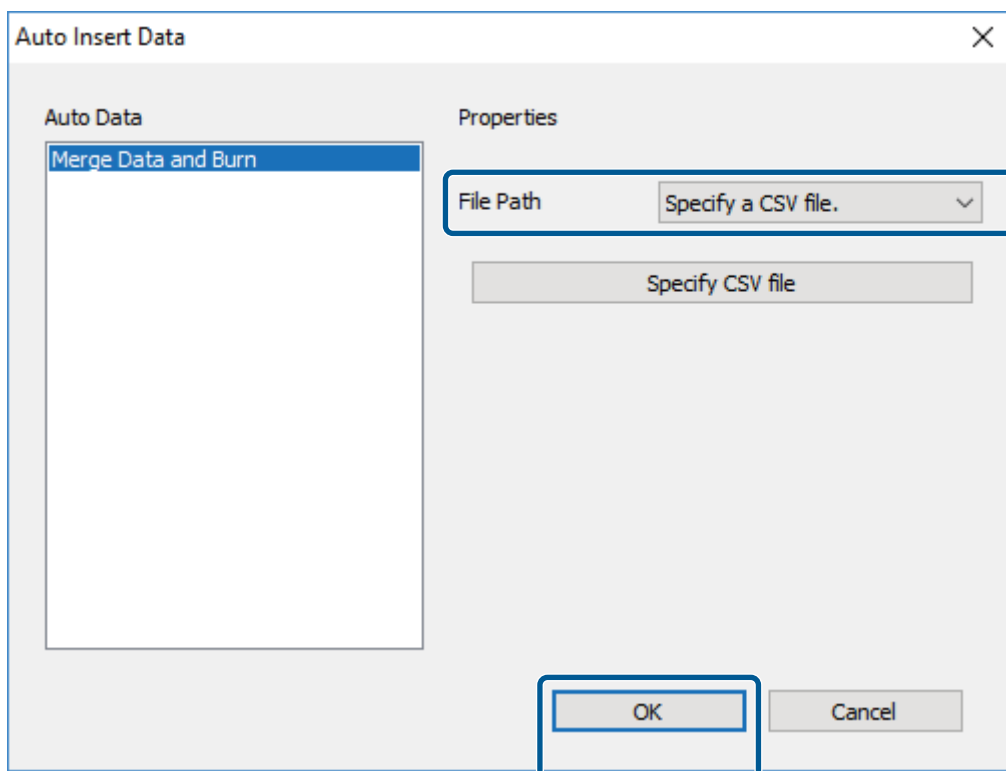

7. When the format check is finished, click the [OK] button.

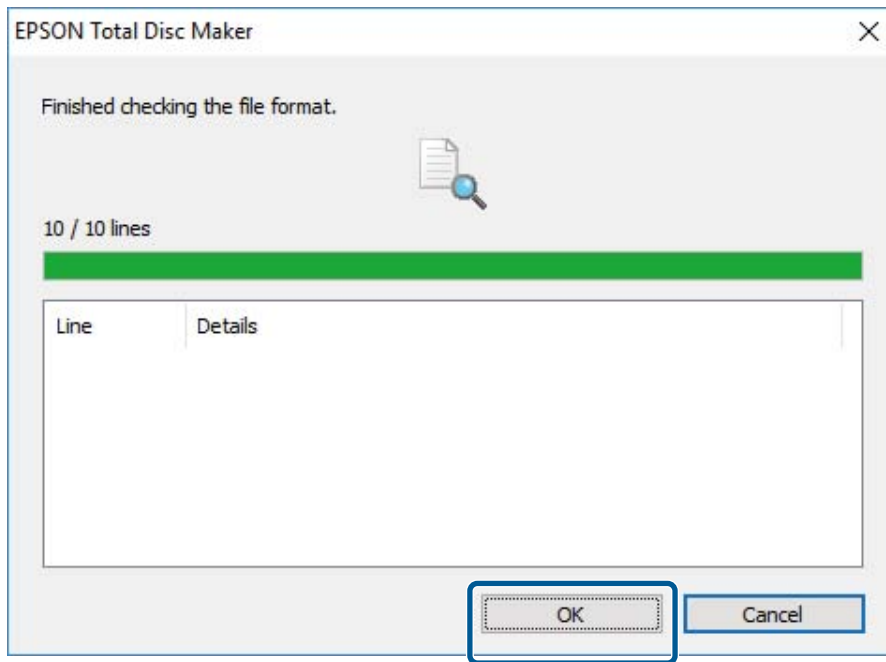
**NOTE**

- If an error is found, click the [Cancel] button and correct the CSV file.
- To read a corrected CSV file, click the [Update] button on the Manage Merge Data screen.

8. Confirm that the disc information for the disc image file that you want to write appears under [Disc Information].

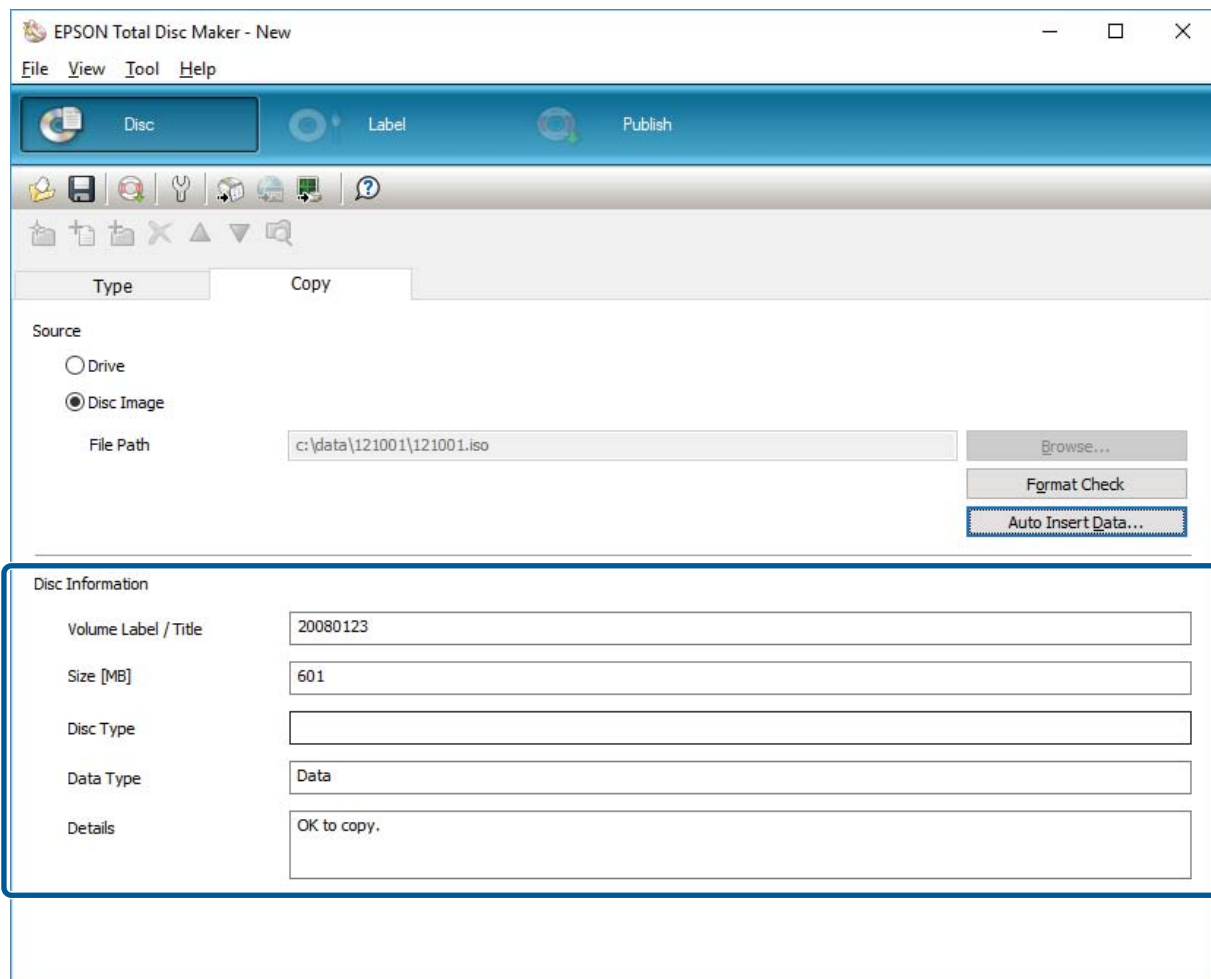
**NOTE**

- Only the disc information for the 1st disc will appear.
- For more information about how to publish a disc, please refer to the User's Guide for the product you are using.

This completes the procedure for configuring the Merge function (disc image).

Appendix

Trademarks

- Windows is a registered trademark of Microsoft Corporation in the United States and/or other countries.
- EPSON and EXCEED YOUR VISION are registered trademarks or trademarks of Seiko Epson Corporation.

All other trademarks are the property of their respective owners and used for identification purpose only.

Cautions

1. No part of this document may be reproduced, stored in a retrieval system, or transmitted in any form or by any means, electronic, mechanical, photocopying, recording, or otherwise, without the prior written permission of Seiko Epson Corporation.
2. The contents of this document are subject to change without notice.
3. While every precaution has been taken in the preparation of this document, Seiko Epson Corporation assumes no responsibility for errors or omissions.
4. Neither is any liability assumed for damages resulting from the use of the information contained herein.
5. Neither Seiko Epson Corporation nor its affiliates shall be liable to the purchaser of this product or third parties for damages, losses, costs, or expenses incurred by the purchaser or third parties as a result of: accident, misuse, or abuse of this product or unauthorized modifications, repairs, or alterations to this product, or (excluding the U.S.) failure to strictly comply with Seiko Epson Corporation's operating and maintenance instructions.
6. Seiko Epson Corporation shall not be liable against any damages or problems arising from the use of any options or any consumable products other than those designated as Original Epson Products or Epson Approved Products by Seiko Epson Corporation.

©Seiko Epson Corporation 2019. All rights reserved.