

TM-S1000II-NW (Network-USB)

Technical Reference Guide

Product Overview

Describes features and general specifications for the product.

Setup

Describes setup and installation of the product.

Advanced Usage

Describes advanced usage methods for the product.

Application Development Information

Describes how to control the scanner and necessary information when you develop applications.

Handling

Describes how to handle the product.

Troubleshooting

Describes what to do when problems occur.

Product Specifications

Provides product specifications and interface specifications.

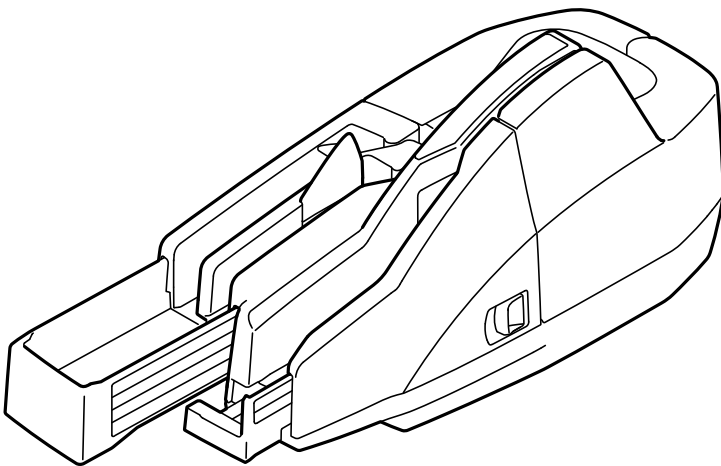

Cautions

- No part of this document may be reproduced, stored in a retrieval system, or transmitted in any form or by any means, electronic, mechanical, photocopying, recording, or otherwise, without the prior written permission of Seiko Epson Corporation.
- The content of this document is subject to change without notice. Please contact us for the latest information.
- While every precaution has been taken in the preparation of this document, Seiko Epson Corporation assumes no responsibility for errors or omissions.
- Neither is any liability assumed for damages resulting from the use of the information contained herein.
- Neither Seiko Epson Corporation nor its affiliates shall be liable to the purchaser of this product or third parties for damages, losses, costs, or expenses incurred by purchaser or third parties as a result of: accident, misuse, or abuse of this product or unauthorized modifications, repairs, or alterations to this product, or (excluding the U.S.) failure to strictly comply with Seiko Epson Corporation's operating and maintenance instructions.
- Seiko Epson Corporation shall not be liable for any damages or problems arising from the use of any options or any consumable products other than those designated as Genuine Epson Products or Epson Approved Products by Seiko Epson Corporation.

Trademarks

Microsoft and Windows are registered trademarks of Microsoft Corporation in the United States and/or other countries.

Mac and macOS are trademarks of Apple Inc., registered in the U.S. and other countries and regions.

Wi-Fi® is a registered trademark of Wi-Fi Alliance®.

QR Code is a registered trademark of DENSO WAVE INCORPORATED in Japan and other countries.



All other trademarks are the property of their respective owners and used for identification purpose only.

©Seiko Epson Corporation 2026

For Safety

Key to Symbols

The symbols in this manual are identified by their level of importance, as defined below. Read the following carefully before handling the product.

 WARNING	You must follow warnings carefully to avoid serious bodily injury.
 CAUTION	Provides information that must be observed to prevent damage to the equipment or loss of data. <ul style="list-style-type: none">• Possibility of sustaining physical injuries.• Possibility of causing physical damage.• Possibility of causing information loss.
CAUTION	Provides information that must be observed to avoid damage to your equipment or a malfunction.
NOTE	Provides important information and useful tips.

Warnings

 WARNING	<ul style="list-style-type: none">❑ Do not set up this product or handle cables during a thunderstorm. There is a risk of electric shock.❑ Never insert or disconnect the power plug with wet hands. Doing so may result in severe shock.❑ Handle the power cable with care. Improper handling may lead to fire or electric shock.<ul style="list-style-type: none">* Do not modify or attempt to repair the cable.* Do not place any heavy object on top of the cable.* Avoid excessive bending, twisting, and pulling.* Do not place the cable near heating equipment.* Check that the plug is clean before plugging it in.* Be sure to push the plug all the way in.❑ Be sure to use the specified power source. Connection to an improper power source may cause fire or shock.❑ Do not place multiple loads on the power outlet. Overloading the outlet may lead to fire.❑ Shut down this product immediately if it produces smoke, a strange odor, or unusual noise. Continued use may lead to fire. Immediately unplug the product and contact qualified service personnel.❑ Never attempt to repair this product yourself. Improper repair work can be dangerous.❑ Never disassemble or modify this product. Tampering with this product may result in injury or fire.❑ Do not allow foreign matter to fall into the product. Penetration by foreign objects may lead to fire.❑ If water or other liquid spills into this product, do not continue to use it. Continued use may lead to fire. Unplug the power cord immediately and contact qualified service personnel.
-------------------------------------------------------------------------------------------------------	------------------------------------------------------------------------------------------------------------------------------------------------------------------------------------------------------------------------------------------------------------------------------------------------------------------------------------------------------------------------------------------------------------------------------------------------------------------------------------------------------------------------------------------------------------------------------------------------------------------------------------------------------------------------------------------------------------------------------------------------------------------------------------------------------------------------------------------------------------------------------------------------------------------------------------------------------------------------------------------------------------------------------------------------------------------------------------------------------------------------------------------------------------------------------------------------------------------------------------------------------------------------------------------------------------------------------------------------------------------------------------------------------------------------------------------------------------------------------------------------------------------------------------------------------------------------------------------------------------------------------------------------------------------------------------------------------------------------------------------------------------------------------------------------------------------

Cautions



- ❑ Do not connect cables in any other way than described in this manual. Improper connection may result in damage to the product or cause fire.
- ❑ Be sure to set this product on a firm, stable, horizontal surface. The product may break or cause injury if it falls.
- ❑ Do not use the product in a humid or dusty place. Excessive moisture or dust may damage the product or cause fire.
- ❑ Do not sit or lean on the product. Do not place heavy objects on the product. Doing so may break the product or cause injury.
- ❑ To ensure safety, unplug this product before leaving it unused for an extended period.
- ❑ Do not use aerosol sprayers containing flammable gas inside or around this product. Doing so may cause fire.

Restriction of Use

If this product is used for applications which require a high level of reliability or safety in terms of functionality or precision for equipment directly related to the operation of aircraft, trains, ships, automobiles etc., disaster or crime prevention equipment, various safety equipment, etc., we ask that you use this product only after including fail-safe and redundancy designs in order to maintain the reliability and safety of said overall systems, ensuring that it is designed in consideration of safety.

This product is not designed for use in applications that require an extremely high level of reliability or safety, such as aerospace equipment, trunk communications equipment, nuclear power control equipment, medical equipment, etc., so we ask that you carefully consider whether or not this product is appropriate for such applications.

Open Source Software License

This product uses open source software in addition to Epson proprietary software.



For information of the open source software used in this product, see the following URL.

<http://xxx.xxx.xxx.xxx/PRESENTATION/ADVANCED/LICENSE/TOP>

For “xxx.xxx.xxx.xxx” in the above URL, input your scanner’s IP address.

Manuals for This Product

The following manuals are available for this product.

<p>Paper manual</p> 	<p>Manuals, such as Setup Guide, included in the product package</p> <p>Explains how to install and set up this product, from checking the bundled items. Precautions for handling this product are also provided. To ensure safe and correct use and to prevent harm to you or others, or damage to property, please read the paper manuals before using the product.</p>
<p>Manuals viewed on computers and smart devices</p> 	<p>User's Manual</p> <p>Describes the functions of this product, how to operate it, information on maintenance, and how to solve various problems. In addition to the URL below, you can also access it from the QR Code attached to the product itself.</p> <p>https://support.epson.net/publist/bsredirect.php?code=M100032</p>
<p>Manuals viewed on computers</p> 	<p>TM-S1000II-NW (Network-USB) Technical Reference Guide (this manual)</p> <p>Describes information necessary to set up this product, perform daily tasks, and develop your own system. You can access the manual from the URL below.</p> <p>For customers in North America: https://www.epson.com/support/</p> <p>For customers in other countries or regions: https://epson.sn</p>

About This Manual

Aim of the Manual

This manual is intended to provide developers with the information they need to develop and design scanner application software.

Manual Content

This manual consists of the following sections.

Chapter 1	Product Overview
Chapter 2	Setup
Chapter 3	Advanced Usage
Chapter 4	Application Development Information
Chapter 5	Handling
Chapter 6	Troubleshooting
Appendix	Product Specifications

Contents

■ For Safety	3
Key to Symbols.....	3
Warnings	3
Cautions.....	4
■ Restriction of Use	4
■ Open Source Software License.....	4
■ Manuals for This Product	5
■ About This Manual	6
Aim of the Manual	6
Manual Content.....	6

Product Overview 11

■ Features	11
■ Product Configuration	12
Model.....	12
Included.....	12
■ Part Names and Functions	13
Body	13
LED Indicators.....	14
Connectors	15
Online and Offline.....	15
■ Status and Errors	16
Status Display	16
Network Connection Status	17
Error Status	18
■ Processing Modes	20
Processing Speed	21
Selectable Processes	22
■ Sensors	23
Paper Sensors	23
Cover Open Sensors.....	24
Other Sensors	24
■ Maintenance Counter.....	26

Setup 27

■ Flow of Setup	27
■ Installing the Scanner	28
Removing the Packing Materials.....	28

Important Notes on Installation	29
■ Connecting the Scanner to the Host Device	30
Connecting via the USB Connector for Network Communication.....	30
Connecting via the Ethernet Connector for Network Communication	30
■ Connecting the AC Adapter	31
Power Switch Cover.....	32
■ Attaching the Connector Cover	33
■ Installing the Franking Cartridge	33
■ Extending the Guides	33

Advanced Usage **34**

■ Network Settings	34
When Using the USB Connector for Network Communication.....	34
When Using the Ethernet Connector for Network Communication	34
■ Web Config	36
How to Start Web Config.....	36
What can be Configured in Web Config.....	38
■ Resetting the Network Settings	39
■ Scanning Demonstration	40

Application Development Information..... **41**

■ Operating Environment	41
Requirements for Using the USB Connector for Network Communication.....	41
Requirements for Using the Ethernet Connector for Network Communication	41
■ Web API	41
■ Utilities	42
TM-S1000II Utility.....	42
Epson Device Admin.....	42
■ Downloading Software	42

Handling **43**

■ Turning the Power On/Off	43
Turning the Power On	43
Turning the Power Off	43
■ Opening the Covers	44
Opening the Scanner Cover	44

Opening the Franker Cover	44
■ Installing and Replacing the Franking Cartridge	45
Important Notes on the Franking Cartridge	45
Installing and Replacing the Franking Cartridge	45
■ Processing Documents	46
Document Process Flow	46
Important Notes on Processing Documents.....	46
How to Set Documents.....	47
How to Remove Documents.....	48
■ Cleaning	49
Cleaning the Image Sensor	49
Cleaning the MICR Unit.....	50
■ Removing a Paper Jam	51
■ Preparing for Transport	51
■ Checking the Nameplate	51

Troubleshooting.....**52**

■ About the QR Code Label on the Scanner	52
■ The Product Does Not Turn On	53
■ The ! Error LED is Lit or Flashing	53
■ Paper Jam	53
■ Problems with Reading Quality	53
Cannot Read Magnetic Ink Characters Correctly	53
Scan Quality is Poor	53
■ Documents are not Fed Properly	53
■ Scanner Clock is Not Right	54

Product Specifications.....**55**

■ General Specifications	55
Scanning Specifications.....	56
Paper Specifications	57
Scannable Area	58
MICR Readable Area	58
Area for Electric Endorsement.....	59
Area for Franking.....	59
Electrical Specifications	59
Environmental Conditions.....	60
External Dimensions and Weight	61
■ Interface Specifications	62
USB (type-B) Interface	62

Network Interface Specifications	62
----------------------------------------	----

Product Overview

This chapter describes features and specifications of the product.

Features

The TM-S1000II series is a compact check scanner that integrates functions for processing business documents such as checks.

The TM-S1000II series can perform four operations in a single pass: scanning front and back sides of a document, reading a magnetic ink character recognition (MICR) line, and franking.

What the Scanner Does while a Document Pass Through

- Read magnetic ink character recognition (MICR) line (E13B, CMC7) on checks
- Obtain image data scanned from both sides of a document
- Scan and recognize OCR A/B fonts in document images
- Add digital endorsement to the images of the front and back of checks
- Analyze image quality with IQA* function
- Frank (stamp a mark in red ink) a processed document

*: IQA (Image Quality Assurance): Complies with FSTC (Financial Services Technology Consortium) recommendations.

Functions for Accuracy and Efficiency

- Double-feed detection
- Detection of documents improperly loaded
- Function for sorting documents into two pockets
- Maintenance counter
- Supports wired network connections via the Network-USB port (network interfaces via USB) and Ethernet port.

Easy Operation

- Easy drop-in paper loading
- Universal design
- Equipped with built-in buzzer
- TM-S1000II series API is provided for easy application development.

Franking Cartridge

- Stamp on electronically settled documents
- Franking or not can be selected according to the data scanned from a document

Product Configuration

Model

Model	dpm	
Model for connecting to Windows computers	30	60
Model for connecting to macOS computers	30	60

* dpm: the number of documents that can be processed in 1 minute (Documents Per Minute)

NOTE

For detailed information about processing speed, see ["Processing Speed" on page 21](#).

Included

- AC adapter
- AC cable
- Power switch cover
- Connector cover
- USB cable (length: 180 cm {70.9 in.})
- Dedicated franking cartridge (Model: EFC-01)
- Manuals

Part Names and Functions

Body

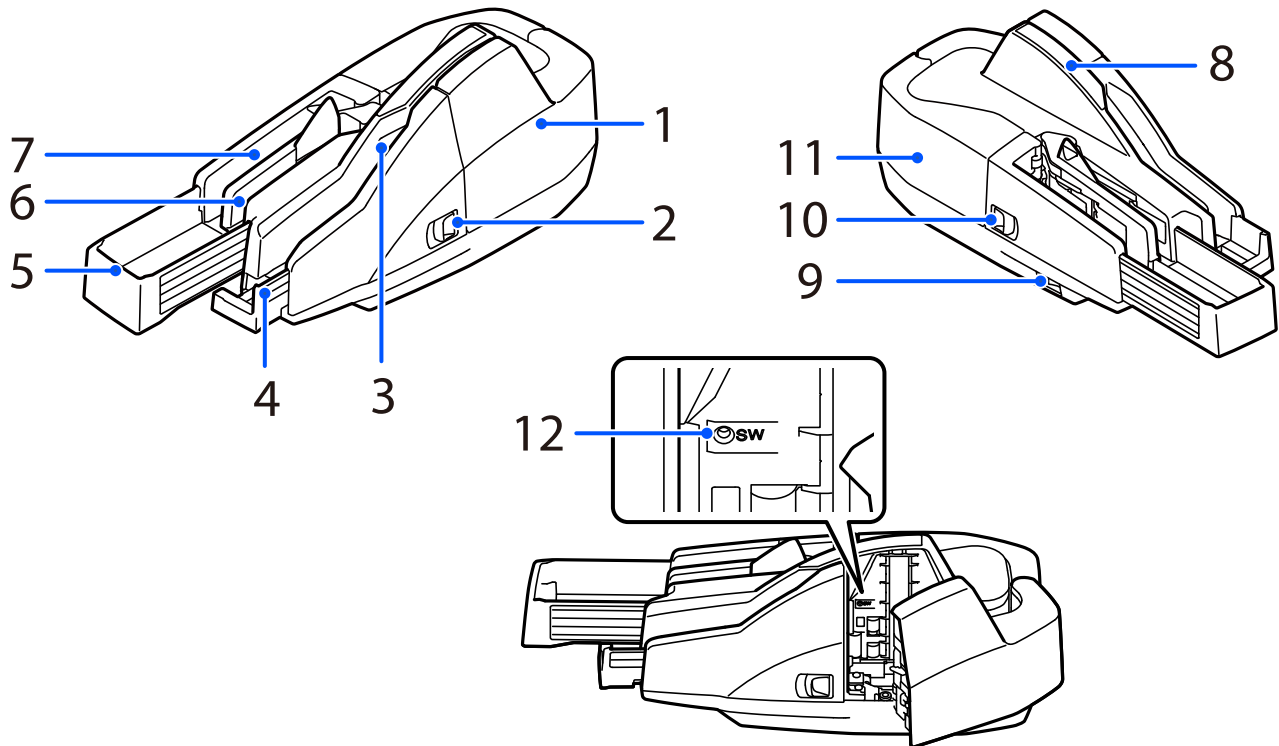





1	Scanner cover	Open this cover to remove jammed paper or to clean the scanner unit.
2	Scanner cover open lever	Move this lever to open the scanner cover.
3	ASF (Auto-Sheet-Feeder)	Load documents here to scan them. Up to 100 sheets can be loaded at a time.
4	ASF guide	Extend this ASF guide to match the length of the documents.
5	Pocket guide	Extend this pocket guide to match the length of the documents.
6	Sub pocket	Processed documents are ejected into these pockets.
7	Main pocket	
8	LED indicators	These LEDs indicate the operating status of the scanner. “LED Indicators” on page 14
9	Power switch	Flip this switch to turn the scanner on or off.
10	Franker cover open lever	Move this lever to open the franker cover.
11	Franker cover	Open this cover to replace the franking cartridge.
12	Network button	This button is located inside the scanner. Open the scanner cover and press the button to initialize the network settings. “Resetting the Network Settings” on page 39

LED Indicators

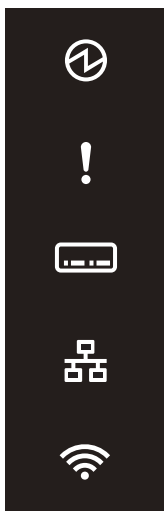

This section describes the function of each LED.

For more information on the scanner statuses indicated by the LEDs, see [“Status and Errors” on page 16](#).





	Power LED	Stays on while the scanner is powered on.
	Error LED	<ul style="list-style-type: none"> • On The scanner is offline, such as when the scanner cover or franker cover is open. • Flashing An error has occurred or the scanner is waiting for documents to be removed.
	Document LED	<ul style="list-style-type: none"> • On The scanner is ready to process documents in the ASF or the scanner is processing documents. • Flashing The scanner is waiting for documents to be loaded.

When using the USB connector for network communication

	Ethernet LED	When the scanner is connected to the network using this method, this LED does not function. It remains off except when it flashes upon turning on the scanner.
	Wi-Fi LED	This LED does not function on this scanner. It remains off except when it flashes upon turning on the scanner.





When using the Ethernet connector for network communication

	Ethernet LED	<ul style="list-style-type: none"> • On A LAN cable is connected to the scanner and the scanner is ready to communicate. • Flashing The scanner is temporarily unable to communicate, such as when it is obtaining an IP address after a LAN cable is connected. • Off The scanner is not connected to an Ethernet network.
	Wi-Fi LED	This LED does not function on this scanner. It remains off except when it flashes upon turning on the scanner.

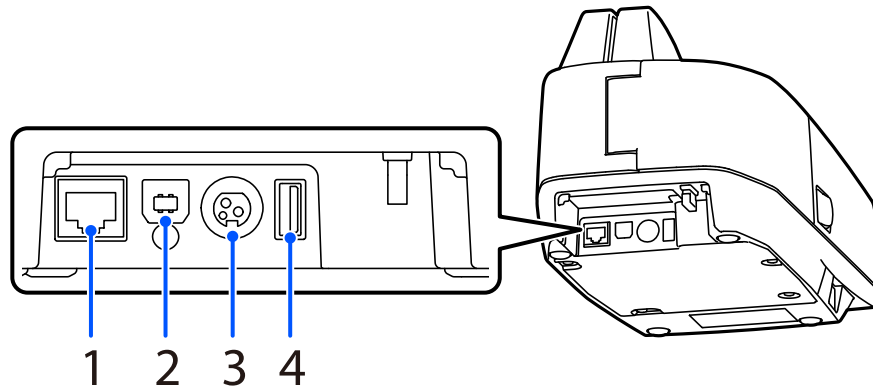
Connectors

The connectors are located on the back side of the scanner.



1		Ethernet connector	Connect a LAN cable.
2		USB connector (Type B)	Connect a USB cable for network communication via USB.
3		Power supply connector	Connect a DC cable for the AC adapter.
4		(Not usable)	The optional Wireless LAN Unit cannot be used.

Online and Offline

Offline

The scanner automatically goes offline under the following conditions:

- During power on (including resetting with the interface) until the scanner is ready
- When the scanner cover is opened
- When the franker cover is opened
- When an error has occurred

Online

The scanner is online and ready for normal processing unless there is a reason to go offline.

Status and Errors

The LEDs on the scanner light up or flash to indicate status of the scanner.

CAUTION



If an error occurs, all scanner operations are stopped.

NOTE

The flashing LED alone does not indicate what the error is. Develop an application that allows the scanner user to identify the error and know the solution.

Status Display

●: ON ●: Flashing ○: OFF -: Ignore the LED light

Power LED 	Error LED 	Document LED 	Scanner Status
●	●	○	The scanner has just been turned on and is performing an initialization operation. The Ethernet LED and Wi-Fi LED also flash.
●*1	●	○	The scanner is performing a turn-off process.
●	○	○	The scanner is online.
●	●	○	The scanner cover or the franker cover is open.
●	○	●*1	The scanner has received a command and is waiting for document(s) to be loaded.
●	○	●	The scanner is ready to process documents or is processing documents.
●	●*1	○	The scanner is waiting for processed documents to be removed from the pocket.
●	●	○	A recoverable or unrecoverable error has occurred. See “Error Status” on page 18 for more information.
●*2	○	○	A RTC (Real Time Clock) error has occurred. See “Scanner Clock is Not Right” on page 54 to correct the setting.
●	○	-	The scanner is updating firmware. The power LED flashes irregularly during the firmware update.

*1: The LED flashing pattern is: lighting for 320 ms followed by a pause for 320 ms.

*2: The LED flashing pattern is: lighting for 4960 ms followed by a pause for 160 ms.

Network Connection Status

- When using the USB connector for network communication

○: OFF

Ethernet LED 	Scanner Status
○	Not used.

- When using the Ethernet connector for network communication

●: ON ●: Flashing* ○: OFF

Ethernet LED 	Scanner Status
●	A LAN cable is connected to the scanner and the scanner is ready to communicate.
●	The scanner is temporarily unable to communicate, such as when it is obtaining an IP address after the LAN cable is connected.
○	The scanner is not connected to an Ethernet network.

* The LED flashing pattern is: lighting for 320 ms followed by a pause for 320 ms.



Error Status

There are two possible error types: recoverable errors and unrecoverable errors.

Recoverable Errors

Processing is no longer possible when recoverable errors occur. They can be recovered easily by turning the power off and then on again or sending an error recovery command from the driver after eliminating the cause of the error.

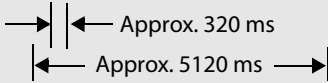
Error	Error LED flashing interval 	Error description	Recovery measure
Mechanical positioning error		One of the following errors during initialization and operation. <ul style="list-style-type: none"> • Error in hopper position detection • Error in framer position detection • Error in pocket switch plate position detection 	Remove the cause (foreign matter or papers) and call BiCancelError of the driver or turn off/on the power.
		The paper length sensor, middle sensor, franking sensor, or ejection sensor has detected paper during initialization.	
Paper jam error		After initialization, paper was detected on the path before the CIS.	Remove the paper and call BiCancelError of the driver or turn off/on the power.
		<ul style="list-style-type: none"> • Paper jam. (Paper length sensor, middle sensor, franking sensor, or ejection sensors detected paper feed error.) • ASF failed in feeding paper. 	Remove the jammed paper and call BiCancelError of the driver or turn off/on the power.
		Too short/long paper detected.	Remove the paper left in the paper path and call BiCancelError of the driver or turn off/on the power.
		Cover opened during paper feeding.	If the paper is left in the paper path, remove it and call BiCancelError of the driver with covers closed or turn off/on the power.

Error	Error LED flashing interval 	Error description	Recovery measure
Reading error*		One of the following errors in the high-speed mode. <ul style="list-style-type: none"> • Multi-feed error • Status other than "Check was correctly inserted" • External noise detected When an application judges an error in the confirmation mode.	Open the franker cover, remove the paper, and call BiCancelError of the driver or turn off/on the power.





* This error occurs only if the scanner is set to stop the document at the franking position instead of ejecting it into the pocket when a reading error occurs.

CAUTION	The error recovery command is valid only if a recoverable error (excluding automatically recoverable errors) occurs.
----------------	----------------------------------------------------------------------------------------------------------------------

Unrecoverable Errors

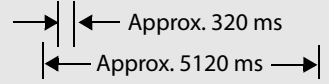
When an unrecoverable error occurs, the product stops operating. If turning the product off and then back on again does not clear the error, servicing is required. Contact qualified service personnel.

 CAUTION	If an unrecoverable error occurs, immediately turn off the scanner by operating the power switch or unplugging the DC cable or the power plug.
-------------------------------------------------------------------------------------------------------	------------------------------------------------------------------------------------------------------------------------------------------------

Error	Error LED flashing interval 	Error description
CPU execution error		The CPU is executing an incorrect address.
Memory Read/Write error		After Read/Write checking, the scanner does not work correctly.
Drive circuit error		There is an abnormality in the drive circuit.
Motor current error		There is an abnormality in the paper feed motor.

Processing Modes

For detailed information about processing modes, see the TM-S1000II-NW Web API Reference Guide.

Processing mode		Description	30 dpm model	60 dpm model
Web API	High-speed mode	The scanner processes a document without stopping from feeding a document until ejecting it.	✓	✓

Processing Speed

The processing speed (dpm: the number of documents that can be processed in 1 minute) when using the driver differ depending on the following conditions.

For 30 dpm model

Processing mode	Paper size	Scan setting ^{*1}	Processing speed ^{*2*3}
High-speed mode	Personal check	All disabled	30 dpm
		One or more enabled	20 dpm
	Business check	All disabled	30 dpm
		One or more enabled	18 dpm

*1: Judgements of the following items can be enabled with the Web API.

- MICR “?” detection result
- IQA result

However, when the IQA judgment function is enabled, the processing speed will be lower than the speed listed in the table above.

*2: The processing speeds apply when the network is not overloaded.

*3: The above processing speeds are not achieved and are reduced when the IQA function is enabled.

For 60 dpm model

Processing mode	Paper size	Scan setting ^{*1}	Processing speed ^{*2*3}
High-speed mode	Personal check	All disabled	60 dpm
		One or more enabled	32 dpm
	Business check	All disabled	45 dpm
		One or more enabled	26 dpm

*1: Judgements of the following items can be enabled with the Web API.

- MICR “?” detection result
- IQA result

However, when the IQA judgment function is enabled, the processing speed will be lower than the speed listed in the table above.

*2: The processing speeds apply when the network is not overloaded.

*3: The above processing speeds are not achieved and are reduced when the IQA function is enabled.

Selectable Processes

The following process settings can be configured from your application software.

- Franking process
 - With franking
 - Without franking
- Ejection process
 - Ejects documents to the Main pocket
 - Ejects documents to the Sub pocket
 - Does not eject documents
 - Waterfall (When the first pocket becomes nearly full with ejected documents, automatically switches to the other pocket)
- Electric endorse
 - With electric endorsing
 - Without electric endorsing

Each process is performed based on the parameters shown below.

	High-speed mode	Confirmation mode
Franking process	<ul style="list-style-type: none"> • Double-feed detection result • Incorrect insertion detection result • External noise detection result 	<ul style="list-style-type: none"> • Double-feed detection result • Incorrect insertion detection result • External noise detection result • Magnetic waveform detection result • MICR "?" detection result • IQA result • Select the check items with the application software*
Ejection process	<ul style="list-style-type: none"> • Double-feed detection result • Incorrect insertion detection result • External noise detection result 	<ul style="list-style-type: none"> • Double-feed detection result • Incorrect insertion detection result • External noise detection result • Magnetic waveform detection result • MICR "?" detection result • IQA result • Select the check items with the application software*
Electric endorse	<ul style="list-style-type: none"> • Double-feed detection result • Incorrect insertion detection result • External noise detection result • Magnetic waveform detection result • MICR "?" detection result • IQA result 	<ul style="list-style-type: none"> • Double-feed detection result • Incorrect insertion detection result • External noise detection result • Magnetic waveform detection result • MICR "?" detection result • IQA result • Select the check items with the application software

* You can use your application software to select what to check through the Web API.

NOTE

If the waterfall function is enabled, the setting of the ejection process is ignored. The waterfall function automatically switches to the other pocket when the first pocket becomes nearly full with ejected documents.

Sensors

There are 7 paper sensors, 2 cover open sensors, and 5 other sensors.

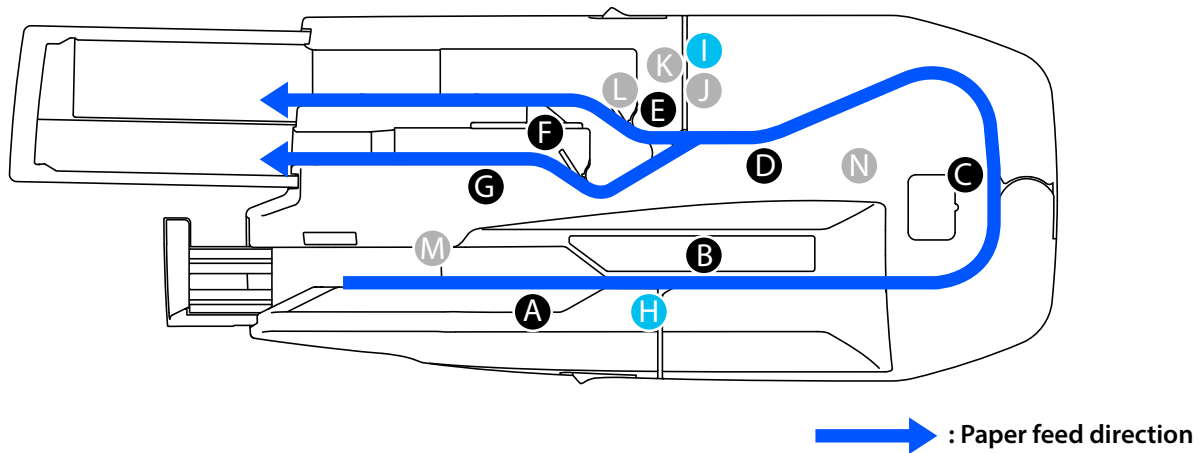

Paper Sensors

ASF sensor (A)

This sensor is located in the feeder paper path. It detects when a document is in the ASF. When the sensor detects a document, the  document LED lights if scanning is possible.

Paper length sensor (B)

This sensor is located in the feeder paper path. It is mainly used for internal processing, but also includes a function for detecting a piece of paper remaining in the feeder path in the event of a paper jam or the like.

Middle sensor (C)

This sensor is located in the feeder paper path. It is mainly used for internal processing, but also includes a function for detecting a piece of paper remaining in the feeder path in the event of a paper jam or the like.

Franking sensor (D)

This sensor is located in the feeder paper path. It detects when a document has reached the franking printing section.

Eject sensor (E)

This sensor is located in the feeder paper path. It detects whether a document is properly ejected and stored in a pocket.

Main pocket nearly full sensor (F)

This sensor is located in the Main pocket. It detects whether documents stored in the pocket need to be removed.

NOTE

- The sensor detects the nearly full status when the thickness of the documents in the Main pocket exceeds the specified value (80 or more of documents whose thickness is 0.13 mm without folds, wrinkles, or roughness).
- To prevent paper jams, use the scanner with the setting to stop continuous processing when it detects that the pocket is almost full. For more information on settings, see the TM-S1000II-NW Web API Reference Guide.

Sub pocket nearly full sensor (G)

This sensor is located in the Sub pocket. It detects whether documents stored in the pocket need to be removed.

NOTE

- The sensor detects the nearly full status when the thickness of the documents in the Sub pocket exceeds the specified value (40 or more of documents whose thickness is 0.13 mm without folds, wrinkles, or roughness).
- To prevent paper jams, use the scanner with the setting to stop continuous processing when it detects that the pocket is almost full. For more information on settings, see the TM-S1000II-NW Web API Reference Guide.

Cover Open Sensors

Scanner cover open sensor (H)

This sensor detects the opening/closing of the scanner cover. The scanner automatically goes offline when the cover is opened. It goes back online when the scanner cover is closed.

Franker cover open sensor (I)

This sensor detects the opening/closing of the franker cover. The scanner automatically goes offline when the cover is opened. It goes back online when the franker cover is closed.

Other Sensors

Franking cartridge sensor (J)

This sensor detects whether the franking cartridge is installed or not.

Franking cartridge position sensor (K)

The franking cartridge is installed in the franking cartridge holder, and the franking operation is achieved by a motor driving the cartridge holder. The scanner has a franking cartridge sensor for detecting the position of the cartridge holder.

Pocket switch plate sensor (L)

Since the scanner can eject processed documents into either of two pockets, it is equipped with a switch plate that switches which pocket the documents are ejected into. This sensor detects the position of the switch plate.

Hopper position sensor (M)

This sensor is located in the ASF. It detects the position of the hopper, which holds documents in place.

Paper thickness sensor (N)

When more than one document is fed into the scanner at a time, this sensor detects the thickness and unevenness of the fed documents. Thus, the scanner can detect a double-feed error.

NOTE

Even if a double feed is detected, it is still possible to obtain MICR and image data that has been read, and to carry out print electronic endorsements and franking.

Maintenance Counter

The TM-S1000II series has the maintenance counter to get the following counts.

- Documents fed from the ASF: Counts the number of times a document is fed from the ASF.
- Scanned documents: Counts the number of times a document is scanned by the image scanner.
- MICR line scanning: Counts the number of times a MICR line is scanned.
- Hopper open/close: Counts the number of times that the hopper in the ASF switches from the closed state to the open state.
- Franking: Counts the number of times that the franker is driven.
- Pocket switching: Counts the number of times the pocket from which documents are ejected switches from the Main pocket to the Sub pocket.
- Total operation hours: Counts the number of hours that the power has been on.

Counter	Counter type	Number of times or Hour
Documents fed from the ASF	Resettable	1 to 4,294,967,295 times
	Cumulative	1 to 4,294,967,295 times
Scanned documents	Resettable	1 to 4,294,967,295 times
	Cumulative	1 to 4,294,967,295 times
MICR line scanning	Resettable	1 to 4,294,967,295 times
	Cumulative	1 to 4,294,967,295 times
Hopper open/close	Resettable	1 to 4,294,967,295 times
	Cumulative	1 to 4,294,967,295 times
Franking	Resettable	1 to 4,294,967,295 times
	Cumulative	1 to 4,294,967,295 times
Pocket switching	Resettable	1 to 4,294,967,295 times
	Cumulative	1 to 4,294,967,295 times
Total operation hours	Resettable	1 to 71,582,788 hours
	Cumulative	1 to 71,582,788 hours

Setup

This chapter describes setup and installation of the product.

Flow of Setup

This chapter consists of the following sections along with the setup flow of the product.

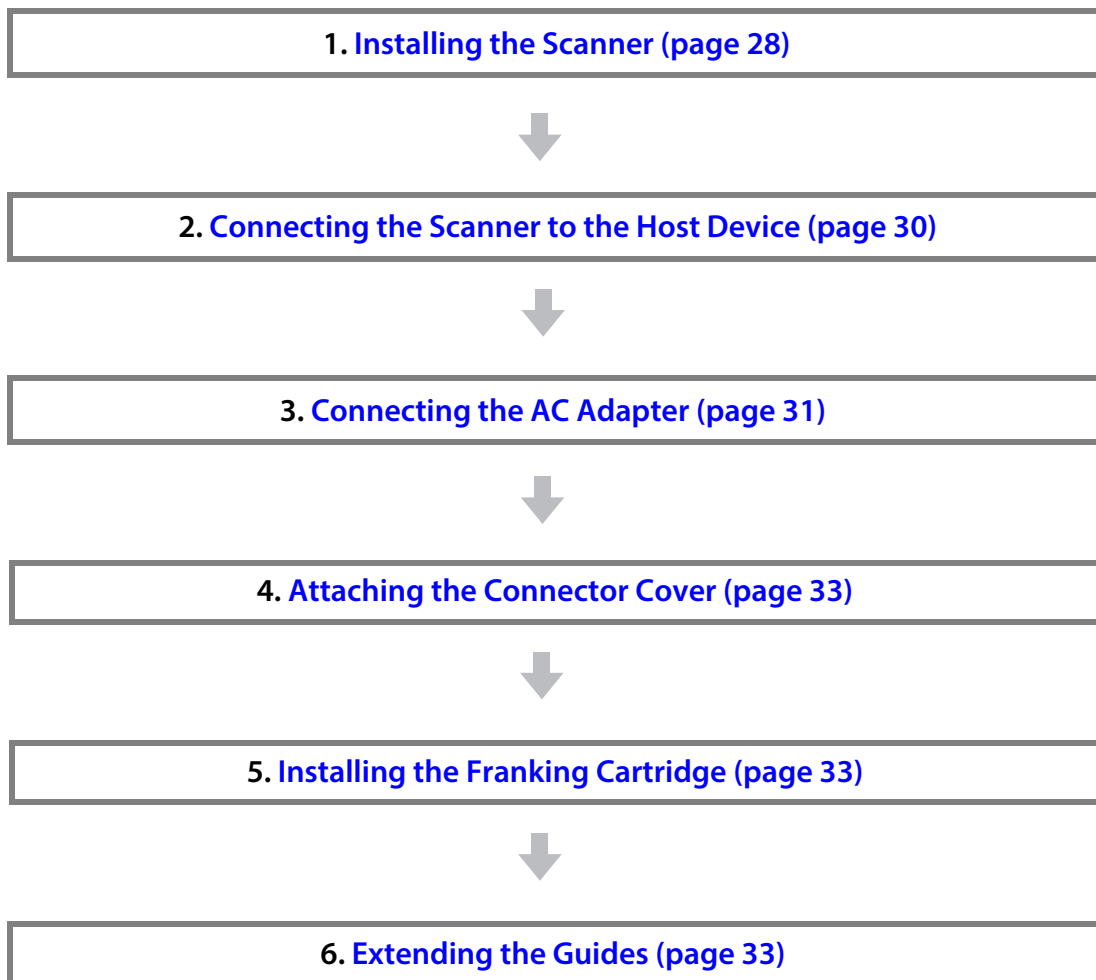

Installing the Scanner

You can install this scanner only horizontally.

Removing the Packing Materials

Packing materials are attached to the scanner to protect it from shocks during transportation. Before installing the scanner, remove the packing materials shown below.

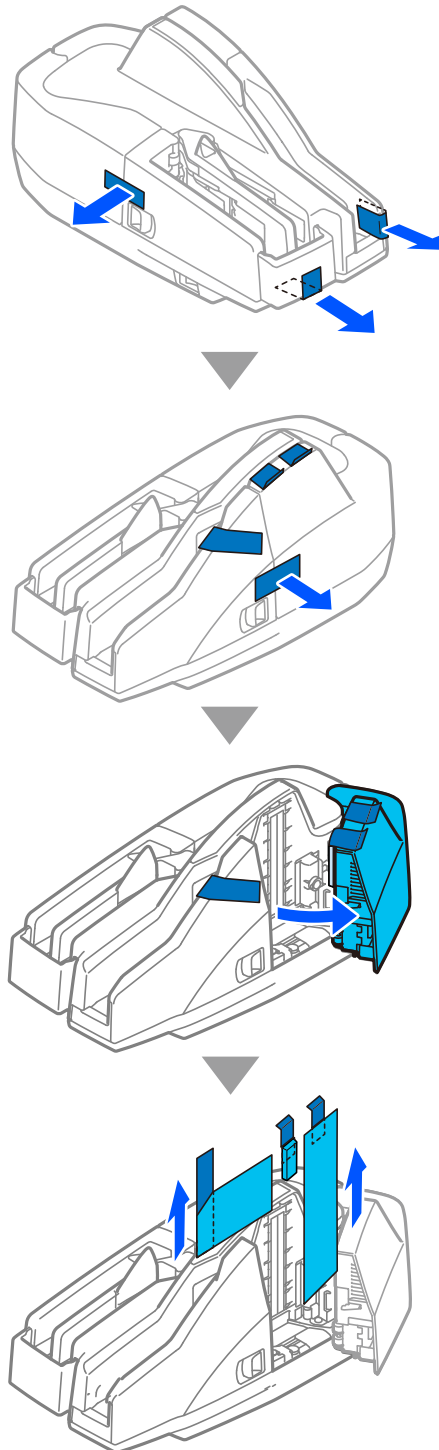

Important Notes on Installation

- Install the product horizontally (within $\pm 5^\circ$).
However, when installed with the left side of the pocket raised, the number of sheets stored may not meet the specifications even if the inclination is less than 5° depending on the condition of the document.
- Do not place the scanner in dusty locations.
- Do not catch cables or allow foreign matter under the scanner.
- Do not subject the scanner to abnormal impact while it is operating. This may cause defective readings.
- Do not install the scanner near electronic devices that generate strong magnetic fields. Otherwise, the scanner may stop reading an MICR line and generate an error in order to avoid reading it incorrectly. If the error occurs, take the following measures to reduce the effects of electromagnetic radiation.
 - * Install the scanner away from the electronic device that generates strong magnetic fields.
 - * Install a shield plate (steel plate or shield material, etc.) that can prevent electromagnetic waves between the electronic device that generates strong magnetic fields and the scanner.

Connecting the Scanner to the Host Device

Connecting via the USB Connector for Network Communication

Connect the host computer to the scanner with the included USB cable.

CAUTION

- Be sure to use the USB cable that is included with the scanner.
- Pass the USB cable through the USB cable securing hook as shown below to prevent the cable from falling off.

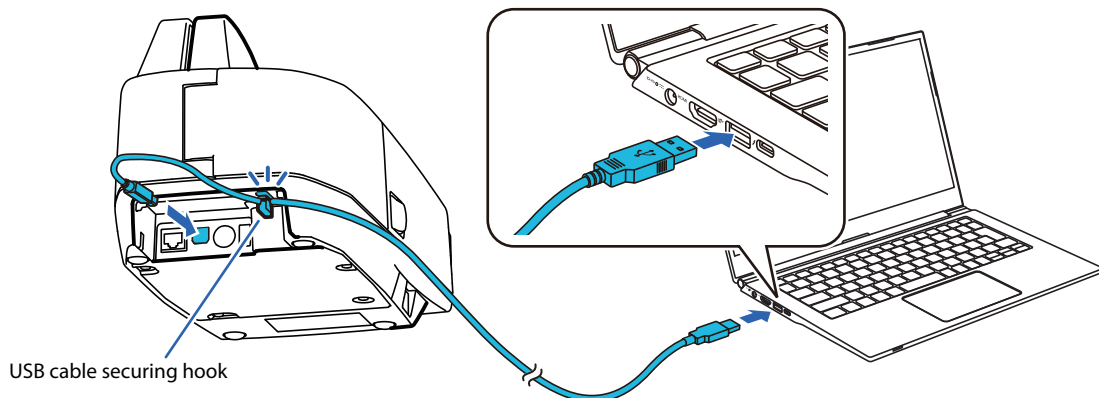

See “[Network Settings](#)” on page 34 for network connection settings.

Connecting via the Ethernet Connector for Network Communication

Connect a LAN cable to your router or hub.

NOTE

Connect the scanner to the network before turning it on. Otherwise, the scanner will not function properly.

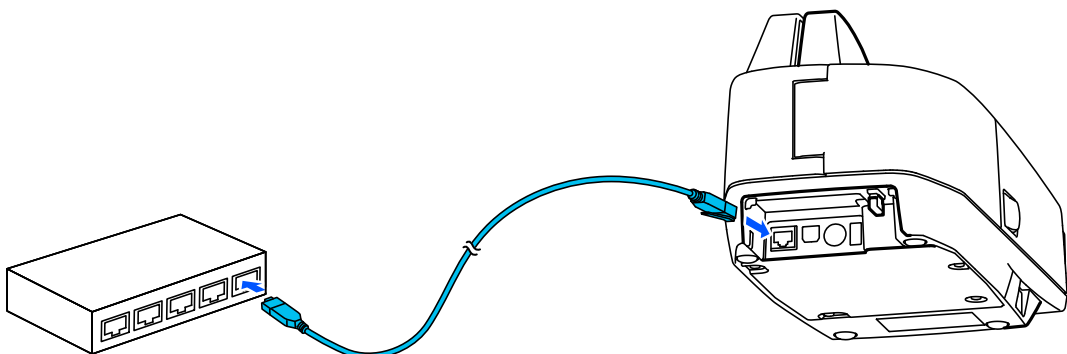

See “[Network Settings](#)” on page 34 for network connection settings.

Connecting the AC Adapter



- Be sure to use only the specified AC Adapter [AC adapter, C1] or [PS-190]. Using a nonstandard power supply can result in electric shock and fire.
- Never insert the AC cable plug into a wall outlet that does not meet the input voltage of the AC adapter. Doing so may result in damage to the scanner.
- If a malfunction occurs with the AC adapter or scanner, immediately turn off the scanner and unplug the AC cable from the wall outlet.

CAUTION

When disconnecting the DC cable of the AC adapter from the scanner, make sure that the AC cable is not connected, and then hold the arrow-printed portion of the connector to pull it straight out.

Arrow-printed portion of the connector

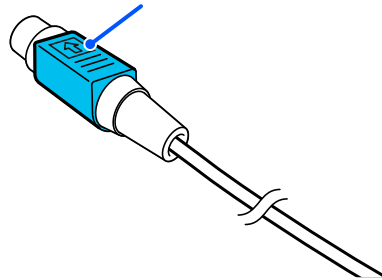

- 1 Make sure the power switch is in the off position and the scanner is turned off. Be sure the AC cable is not plugged into a wall outlet.
- 2 Connect the AC cable to the AC adapter.

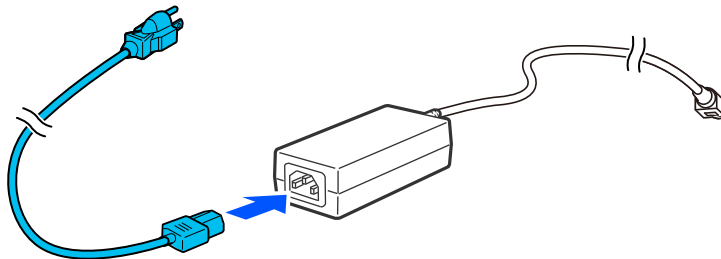

- 3 Connect the AC adapter to the scanner with the DC cable of the AC adapter.

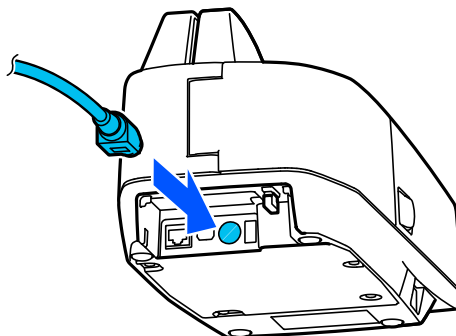

4 Plug the AC cable into a wall outlet.

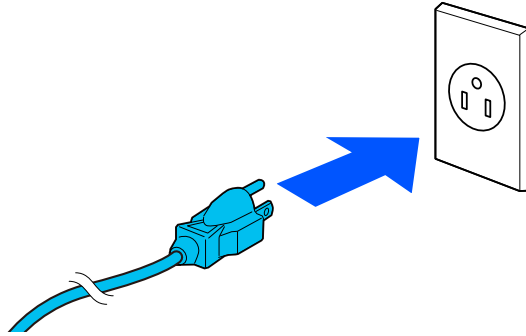

5 Flip the power switch to the | ON position to turn on the scanner.

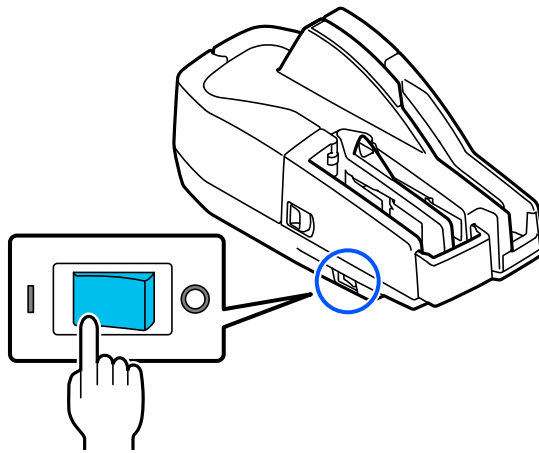

Power Switch Cover

The power switch cover is intended to prevent the power switch from being pressed accidentally. To use the cover, attach it over the power switch. To turn the power on or off after the cover is attached, press the switch through the hole in the cover with a thin stick or similar object.

When storing the scanner or not using it for a long period of time, turn it off with the power switch and unplug the power cable.



If a problem occurs with the scanner with the power switch cover attached, unplug the power cable immediately. Continued use may result in a fire hazard.

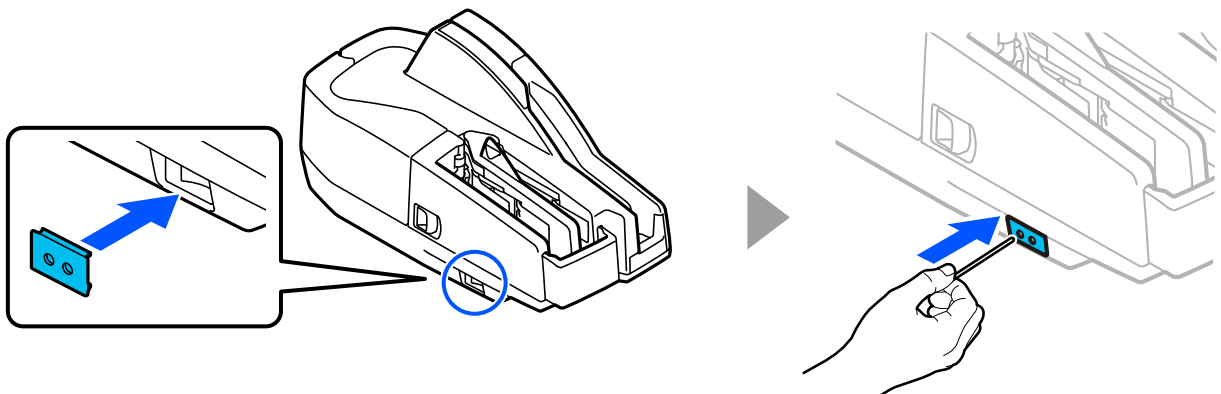

Attaching the Connector Cover

When using the connector cover, attach it as shown in the figure.

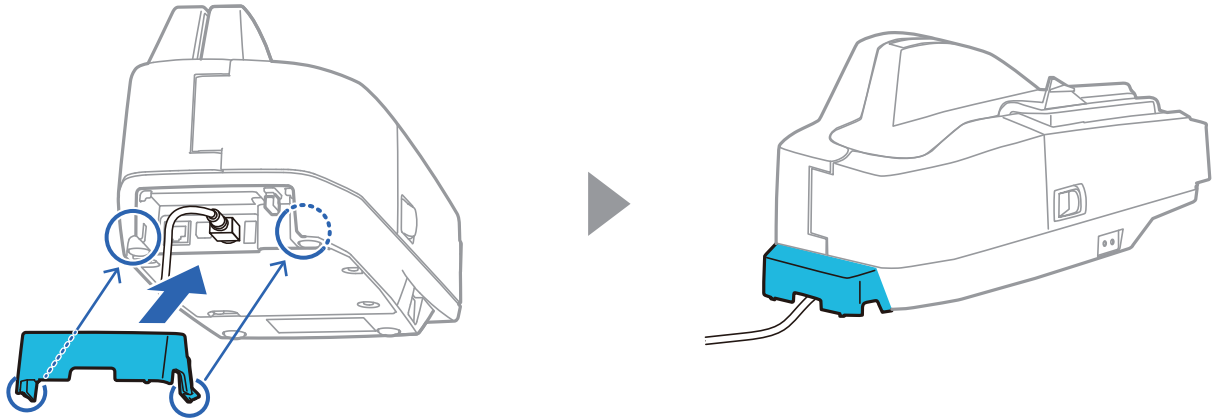

Installing the Franking Cartridge

For instructions on how to install the franking cartridge, see [“Installing and Replacing the Franking Cartridge”](#) on page 45.

Extending the Guides

Extend both the pocket guide and the ASF guide.

CAUTION

Before using the scanner, be sure to pull the pocket guide out far enough to allow the processed documents to fit inside the pocket. Otherwise, a paper jam may occur.

The ASF guide supports loaded documents so that each of the documents is fed straight into the scanner. Extend the ASF guide according to the length of the documents.

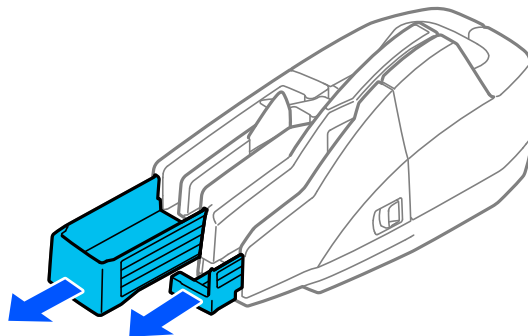

Advanced Usage

Network Settings

This section provides detailed instructions for connecting the scanner to your network.

When Using the USB Connector for Network Communication

No network configuration is required when using this method.

The scanner's IP address is "192.168.192.168" and the subnet mask is "255.255.255.0". Additionally, the scanner functions as a DHCP server and assigns the IP address "192.168.192.10" to connected devices.

When Using the Ethernet Connector for Network Communication

Configure the scanner's network settings from your computer using the TM-S1000II Utility and Web Config, a web application pre-installed in the scanner. The setting process is as follows.

1. Use TM-S1000II Utility to set the scanner's network segment to the same segment as the computer. This is necessary to open the scanner's Web Config from your computer.
2. Configure the scanner's network settings in Web Config.

Setup Procedure

Follow the steps below to set up the scanner.

- 1 Using a LAN cable, connect the scanner via a hub to the same network as the computer on which the TM-S1000II Utility is installed.**
- 2 Turn on the scanner.**
- 3 Start the TM-S1000II Utility.**
- 4 Select the target scanner and click [OK].**
- 5 Click [Display the Web Config] to start Web Config.**
- 6 Select "Advanced Settings" to log in to Web Config.**

If the product is in its factory default state, no user name has been set. Therefore, do not enter anything in the "User Name" field. The user name can be set in the "Change Administrator Password" screen.

The default password is the serial number of the scanner. The serial number can be found on the nameplate affixed to the scanner. See ["Checking the Nameplate" on page 51](#) for the location of the nameplate.

To improve security, it is recommended to change the administrator password from the default pass-

word. The password can be changed from [Advanced Settings] - [Product Security] - [Administrator Password] in Web Config. It can also be changed using TM-S1000II Utility.

- 7** Select the **Network** tab, and change the settings based on information obtained from your network administrator.
- 8** Click [Refresh] to send the changes to the scanner.

Web Config

Web Config is a scanner's built-in web page that allows you to check and change scanner settings on your browser.

To use Web Config, you need to set your computer's IP address to the same segment as the scanner.

How to Start Web Config

1 Start your web browser on a computer or smart device on the network and enter the IP address of the scanner in the address field.

- **When using the USB connector for network communication**
(Fixed to the following IP address)

HTTPS	HTTP
https://192.168.192.168/	http://192.168.192.168/

- **When using the Ethernet connector for network communication**

Example for HTTPS	Example for HTTP
IPv4: https://192.0.2.111/ IPv6: https://[2001:db8::1000:1]/	IPv4: http://192.0.2.111/ IPv6: http://[2001:db8::1000:1]/

2 After Web Config starts, select the menu you wish to configure.

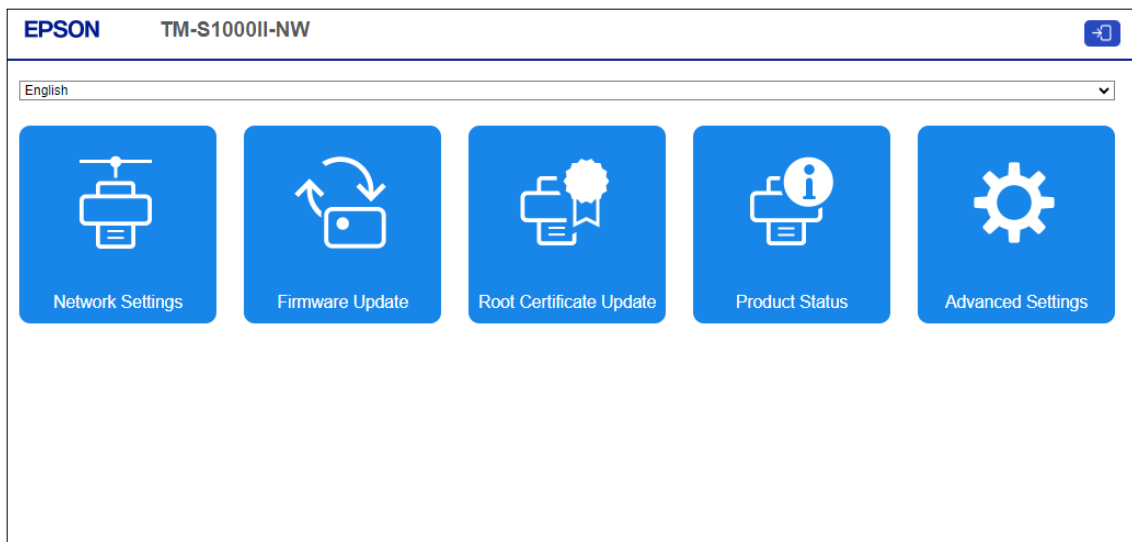

3 When the authentication screen appears, enter your password and log in.

If the product is in its factory default state, no user name has been set. Therefore, do not enter anything in the "User Name" field. The user name can be set in the "Change Administrator Password" screen.

The default password is the serial number of the scanner. The serial number can be found on the nameplate affixed to the scanner. See ["Checking the Nameplate" on page 51](#) for the location of the nameplate.

To improve security, it is recommended to change the administrator password from the default password. The password can be changed from [Advanced Settings] - [Product Security] - [Administrator Password] in Web Config. It can also be changed using TM-S1000II Utility.

NOTE

Enable JavaScript in your browser. Because a self-signed certificate owned by the scanner is used when accessing HTTPS, a warning will appear in the browser when Web Config is started.

What can be Configured in Web Config

For information on what can be configured in Web Config, refer to the Web Config Reference Guide.

The Web Config Reference Guide can be obtained from the URL listed in [“Downloading Software”](#) on page 42.

Resetting the Network Settings

Follow the steps below to restore the network settings to the factory default.

- 1** Be sure that the scanner is turned on and in normal (online) condition.
- 2** Move the scanner cover open lever to open the scanner cover.

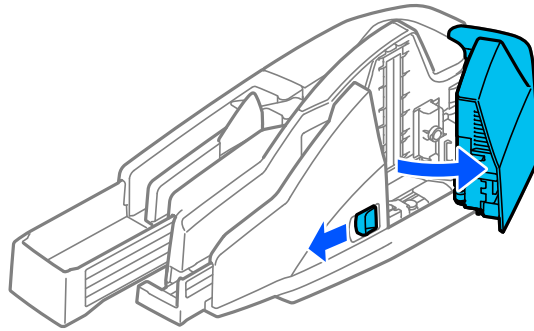

- 3** Press and hold the network button for at least 3 seconds.
The buzzer sounds and the Ethernet LED and Wi-Fi LED flash.
The LEDs will turn off when the resetting the network settings is completed.

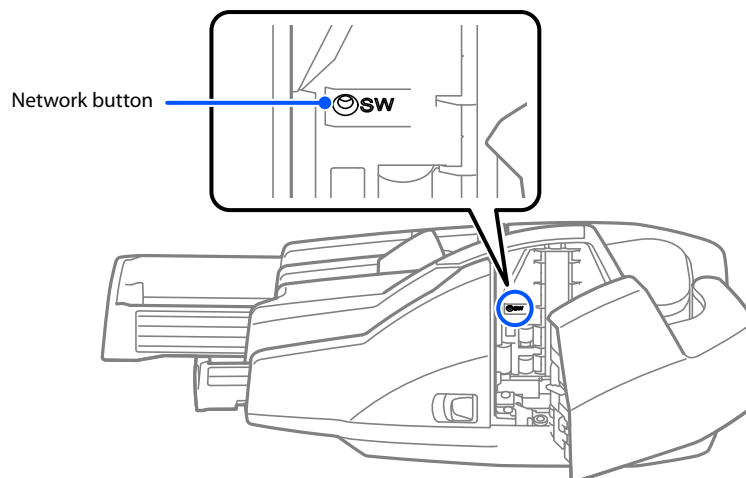

Scanning Demonstration

The Scan Demo function can be activated by entering the IP address of the scanner and /demo in the address field of your web browser.

Example: <http://xxx.xxx.xxx.xxx/demo>

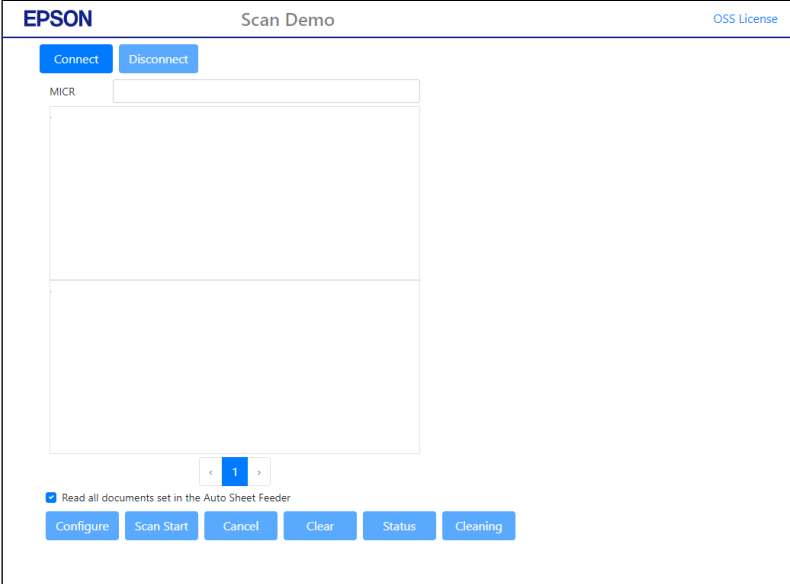

Application Development Information

This chapter describes product control methods and the information required to develop applications used by the product.

Operating Environment

The operating environment required to get the most out of the product's basic specifications differs depending on the connection method.

Requirements for Using the USB Connector for Network Communication

- PC
 - CPU: At least Intel Celeron 3205U 1.5 GHz or the equivalent
 - Memory: 1 GB or more, or more than the minimum memory size required by your OS
 - Storage: At least 30 MB free space is required to install the driver
 - Interface: USB2.0 Hi-speed

Requirements for Using the Ethernet Connector for Network Communication

- PC
 - CPU: At least Intel Celeron 3205U 1.5 GHz or the equivalent
 - Memory: 1 GB or more, or more than the minimum memory size required by your OS
- Tablet
 - CPU: Dual-core 1.8 GHz equivalent or higher
 - Memory: At least 512 MB
- Network environment
 - Wired LAN: 10BASE-T/Full duplex or higher

Web API

TM-S1000II-NW can scan over a network using the Web API pre-installed in the scanner itself.

The following functions are available.

- Scanning a document
- Reading a MICR line on a check
- Franking a document

For more information, see the TM-S1000II-NW Web API Reference Guide.

Utilities

The utilities described below are available for application development.

For details about functions and support environments, refer to the documentation that comes with each utility.

TM-S1000II Utility

This utility runs on a host PC and allows you to configure the scanner settings and run operation check.

You can use Web Config to perform the following functions.

- Check and change the current settings
- Save and restore the current settings
- Perform operation checks

Epson Device Admin

This utility runs on a server and host PC, and allows you to remotely maintain and support multiple scanners at once.

It has the following functions.

- Monitor alerts/errors
- Monitor consumables information
- Update scanner's firmware

Downloading Software

You can obtain software and manuals from one of the following URLs.

For customers in North America, go to the following web site:

 <https://www.epson.com/support/>

For customers in other countries and regions, go to the following web site:

 <https://epson.sn>

Handling

This chapter describes basic handling of the scanner.

Turning the Power On/Off

This section describes how to turn the product on/off.

Turning the Power On

Flip the power switch to the **|** ON position to turn on the scanner.

The  power LED will light up and the scanner will turn on.

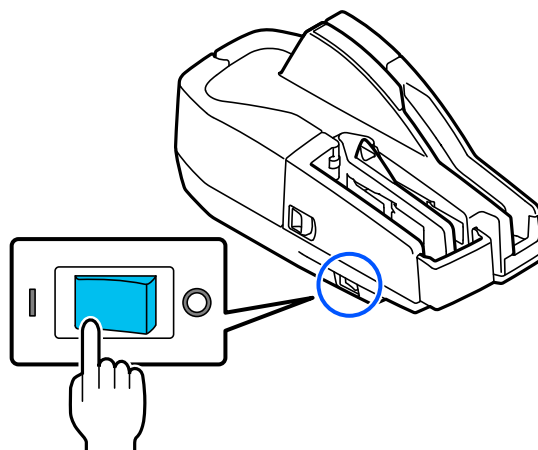

Turning the Power Off

Flip the power switch to the **○** OFF position to turn off the scanner.

The  power LED will stop flashing, all LEDs will turn off, and the scanner will turn off.

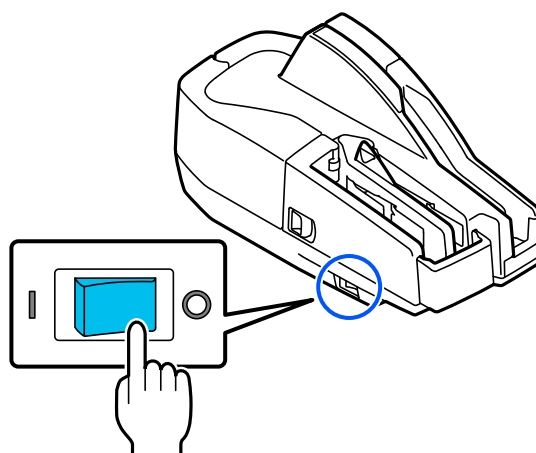

Opening the Covers

CAUTION

Do not open any cover of the scanner during operation, such as while scanning a document. Doing so may cause a scanning error, MICR error, or paper jam error.

Opening the Scanner Cover

Move the scanner cover open lever to open the scanner cover.

Open the scanner cover when you clean the image sensor of the scanner or remove jammed paper.

☞ [“Cleaning the Image Sensor” on page 49](#)

☞ [“Removing a Paper Jam” on page 51](#)

CAUTION

Do not touch the image sensor inside the scanner cover with your bare hands.

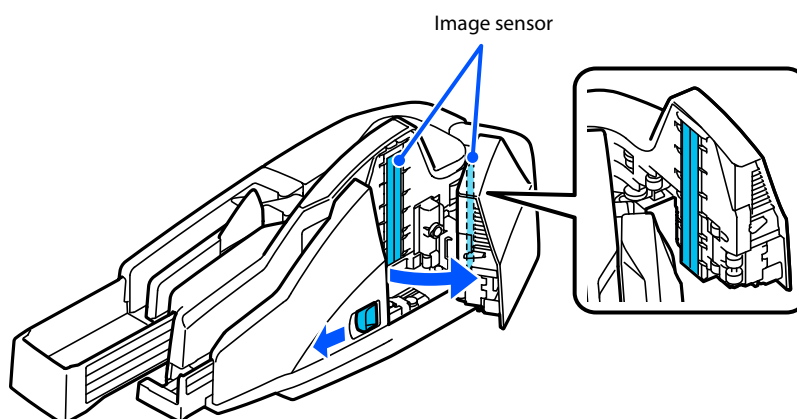

Opening the Franker Cover

Move the franker cover open lever to open the franker cover.

Open the franker cover when you replace the franking cartridge with new one or remove jammed paper.

☞ [“Installing and Replacing the Franking Cartridge” on page 45](#)

☞ [“Removing a Paper Jam” on page 51](#)

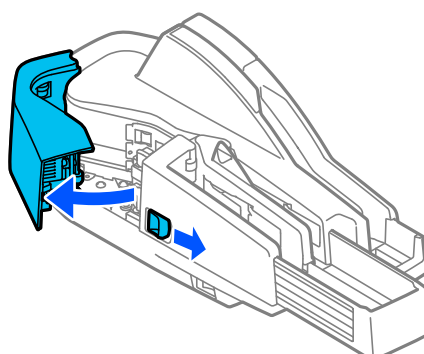

Installing and Replacing the Franking Cartridge

Important Notes on the Franking Cartridge

- Keep the franking cartridges out of the reach of children.
- Do not disassemble franking cartridges.
- Be careful during handling because the ink can permanently stain clothing.
- For the best performance of the scanner, it is recommended to use genuine Epson cartridges. Use of non-genuine Epson products can adversely affect the scanner and print quality and prevent the scanner from realizing its maximum performance.
- Do not unpack the franking cartridge until just before installing it. Print quality will deteriorate if the franking cartridge is left unpacked for an extended period of time.
- Use up the franking cartridge within 18 months from the date of production indicated on the cartridge box.
- Dispose of franking cartridges in accordance with the laws, ordinances, and regulations of your country or region.

Installing and Replacing the Franking Cartridge

Follow these steps to install a franking cartridge for the first time or to replace it.

- 1 Open the franker cover.**
 ["Opening the Franker Cover" on page 44](#)
- 2 When replacing a used franking cartridge, hold the cartridge by its top knob and remove it upward.**

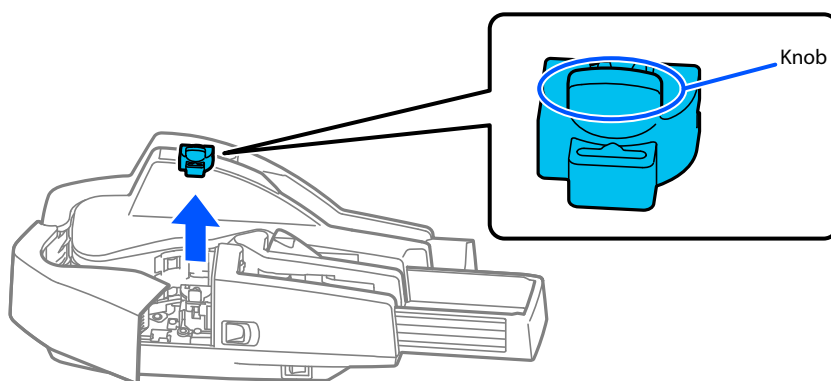

- 3 Carefully insert a new franking cartridge from the top, and push it firmly but gently until it clicks in place.**
- 4 Close the franker cover firmly until it clicks in place.**

Processing Documents

The TM-S1000II series can perform four operations in a single pass: scanning front and back sides of a document, reading a magnetic ink character recognition (MICR) line, and franking.

Document Process Flow

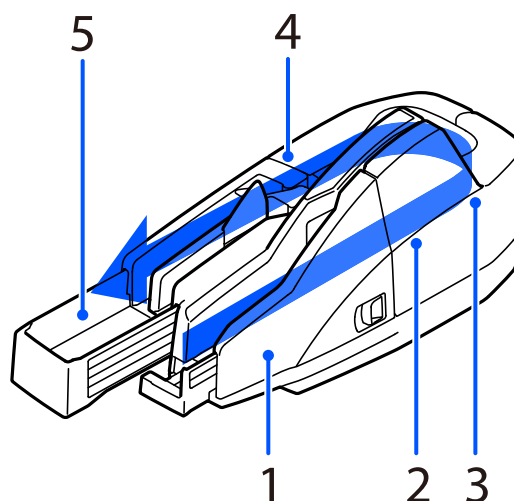

- 1** Documents loaded here are fed into the scanner one by one. See [“How to Set Documents” on page 47.](#)
- 2** Both sides of the document are scanned at the same time.
- 3** Magnetic ink characters recognition (MICR) line on the check is scanned.
- 4** Franking; a fixed message is stamped on the document in red ink.
- 5** Processed documents are ejected here. See [“How to Remove Documents” on page 48.](#)

Important Notes on Processing Documents

- Load paper that meets the requirements listed in [“Paper Specifications” on page 57.](#)
- Do not load copy paper or other multi-ply paper.
- Make sure that the documents have no curl, bending (especially on the corners), warpage, or wrinkles.
- Do not load checks with paper clips, staples, adhesive tape, or other foreign materials attached.
- Do not open the covers while the scanner is processing documents.

How to Set Documents

- 1 When loading multiple documents at one time, neatly align the bottom right corner of the stack of documents.

CAUTION

If the documents are loaded without being aligned, they may not be fed at all, or a paper jam or multi-feed error may occur.

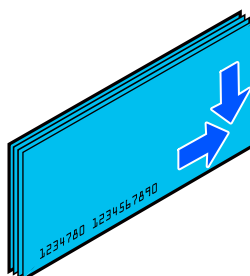

- 2 Load documents into the ASF. If the documents have MICR lines, load them with the MICR line facing outward. Be sure to align the leading edge of the documents with the  mark.

The scanner starts to feed the documents one by one.

CAUTION

- Release your hand as soon as you load documents into the ASF. If the scanner starts feeding before you release your hand, the documents may be skewed resulting in a paper jam or MICR reading error.
- Do not open the covers while the scanner is processing documents.

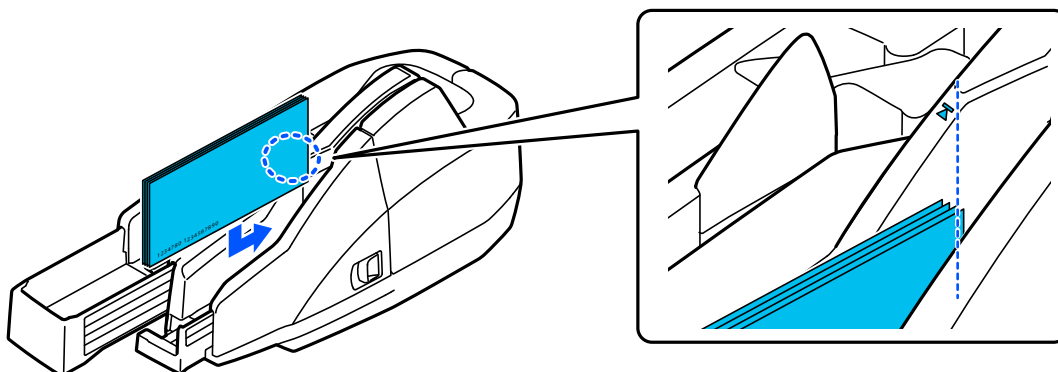

How to Remove Documents

When the documents are ejected, remove the documents.

CAUTION

The number of documents ejected into the pockets should not exceed the capacity (up to 100 sheets for the main pocket and 50 sheets for the sub-pocket). Exceeding the capacity while the scanner is processing documents may result in paper jams.

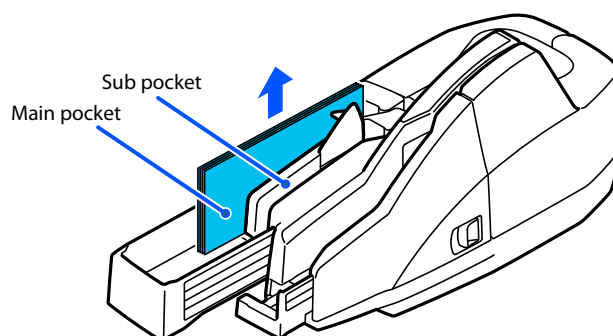
**NOTE**

- With your application software, you can configure the ejection settings, such as which of the two pockets the processed documents will be ejected into, and whether to automatically switch to the other pocket when the first pocket is nearly full.
- You can set the scanner's built-in buzzer to sound when an error occurs, such as a paper jam, in your application software.

Cleaning

Cleaning the Image Sensor

If the image sensor of the scanner becomes dirty with ink, or paper dust, scan quality may deteriorate. Clean the image sensor once a week or every 2,000 scans.

Follow these steps to clean the image sensor.

1 Open the scanner cover.

 ["Opening the Scanner Cover" on page 44](#)

2 Lightly wipe the image sensor shown in the figure below with a soft, dry cloth.

For stubborn stains such as oil or grease, wipe them off with a cloth lightly moistened with alcohol. Then, wipe off the alcohol with a dry cloth.



CAUTION

- Do not use synthetic detergents, benzene, water or other liquids for cleaning. Using them may cause stains on the glass surface.
- Never apply any liquid directly to the glass of the scanner.
- Be careful not to spill liquid into the scanner mechanism or electronic components. This could permanently damage the mechanism and circuitry.

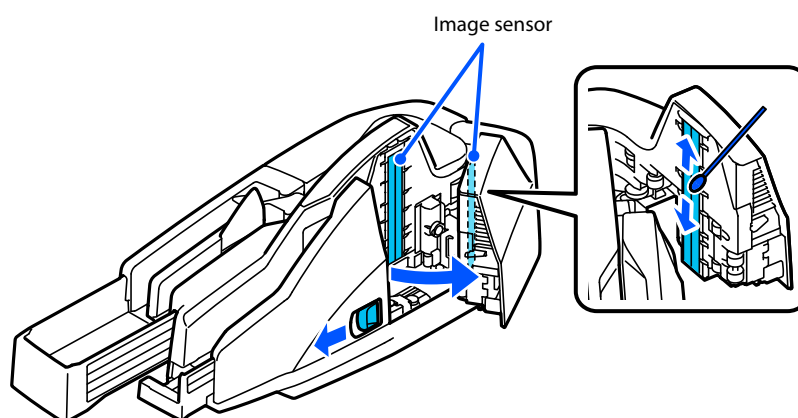

3 Close the scanner cover firmly until it clicks in place.

Cleaning the MICR Unit

Dirt on the MICR unit can cause frequent MICR read errors. The MICR unit should be cleaned once a week or every 2,000 scans.

Use the following cleaning cards manufactured by KICTeam, Inc.

- Waffletechnology® MICR cleaning card (model: KWEPS-CS1B15WS)
- Epson Check Scanner Cleaning Kit (model: KWEPS-KCS2)

Use the TM-S1000II Utility or your application software to clean the MICR unit.



CAUTION

- **Do not use sticky cleaning sheets. They may cause a paper jam or machine failure.**
- **Be sure to dispose of used cleaning sheets.**

NOTE

- For cleaning procedures, see the manual for the TM-S1000II Utility or your application software.
- We recommend cleaning the image scanner after cleaning the MICR unit. See [“Cleaning the Image Sensor” on page 49](#).

Removing a Paper Jam

Open the scanner cover or franker cover to remove the jammed paper.

☞ “Opening the Scanner Cover” on page 44

☞ “Opening the Franker Cover” on page 44

Preparing for Transport

Follow the steps below to transport the scanner.

- 1** Turn off the scanner.
- 2** Confirm that the ① power LED is off.
- 3** Remove the power supply connector.
- 4** Store the pocket guide and the ASF guide inside the scanner.
- 5** Pack the scanner upright.

Checking the Nameplate

The nameplate is affixed to the bottom of the scanner.

It shows the product name, model number, and serial number.

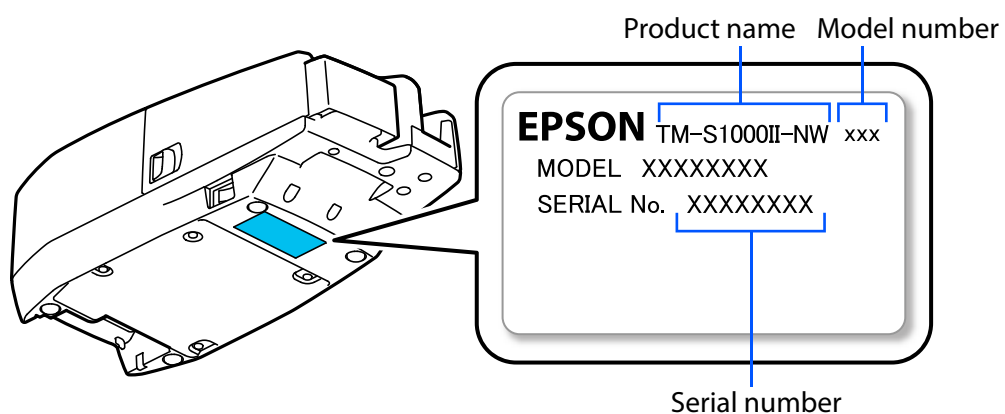

Troubleshooting

This chapter describes how to resolve problems.

Trouble	Reference
The Product Does Not Turn On	page 53
The ! Error LED is Lit or Flashing	page 53
Paper Jam	page 53
Problems with Reading Quality	page 53
Documents are not Fed Properly	page 53
Scanner Clock is Not Right	page 54

About the QR Code Label on the Scanner

By scanning the QR Code on the label attached to the inner side of the scanner cover, you can access the user's manual.

If you encounter any problems while using the scanner, you can use this QR Code to quickly check for troubleshooting.

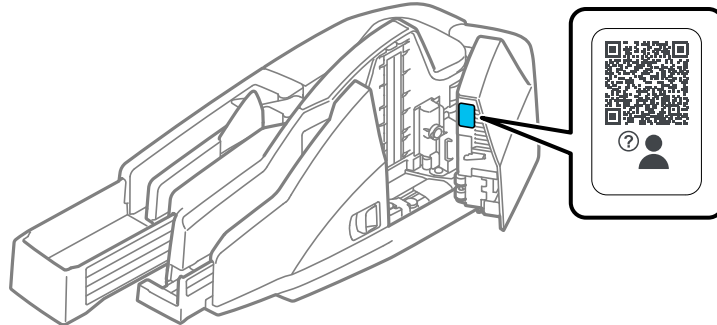

The Product Does Not Turn On

Making sure each connector is oriented correctly, insert the power cable into the product and the power outlet as far as it will go.

 [“Connecting the AC Adapter” on page 31](#)

The ! Error LED is Lit or Flashing

Check the flashing interval of the **!** Error LED to determine what error is occurring and take action.

 [“Error Status” on page 18](#)

Paper Jam

Open the scanner cover or franker cover to remove the jammed paper.

 [“Opening the Covers” on page 44](#)

Problems with Reading Quality

Cannot Read Magnetic Ink Characters Correctly

The MICR head may be dirty. Clean the MICR unit.

 [“Cleaning the MICR Unit” on page 50](#)

Scan Quality is Poor

The scanner glass may be dirty. Clean the scanner glass.

 [“Cleaning the Image Sensor” on page 49](#)

Documents are not Fed Properly

Perform a test scan with three new documents using the TM-S1000II Utility. If the scanner is networked, a test scan can be performed from Web Config.

If the scanner has not been used for more than three months, repeat the test scan until the document is properly fed.

Scanner Clock is Not Right

The scanner has a clock function called RTC (Real Time Clock).

The time setting of the RTC may have been initialized when the scanner is first used. If this is the case, correct the time using the TM-S1000II Utility or Web Config. For instructions on how to correct the time, see the TM-S1000II Utility User's Manual or Web Config Reference Guide.

Product Specifications

General Specifications

Item		Description
Processing speed		30 dpm or 60 dpm depending on the model.
ASF (Auto Sheet Feeder) capacity		Up to 100 sheets of paper that is 0.13 mm or less in thickness.
MICR reader	Reading method	Permanent magnetic bias
	Supported fonts	E13B, CMC7 (Alphabetic characters are not supported.)
OCR reader	Supported fonts	E13B OCR A, OCR B
Electric endorsement		<ul style="list-style-type: none"> • Different images can be pasted on each document. • More than one image can be pasted. • Logos, graphics, and TrueType fonts are available.
Pocket capacity	Main pocket	Up to 100 sheets of paper that is 0.13 mm or less in thickness. The thickness of the stack of paper must be 13 mm or less, including warpage and curl of the paper.
	Sub pocket	Up to 50 sheets of paper that is 0.13 mm or less in thickness. The thickness of the stack of paper must be 6.5 mm or less, including warpage and curl of the paper.
Franking cartridge	Type	Dedicated franking cartridge (EFC-01)
	Ink color	Red
	Life of ink	18,000 times (when printing the default message)
Power supply		Power supply by the included AC adapter (AC Adapter, C1). AC adapter (PS-190) can also be used.
Interface		USB (" USB (type-B) Interface " on page 62) Ethernet
Life* ¹		1,000,000 sheets
MTBF* ²		180,000 hours
MCBF* ³		2,470,000 cycles
Overall dimension (W × H × D)		355 × 176 × 160 mm {14.0 × 6.93 × 6.30 in.}
Weight		Approx. 4.0 kg {8.82 lb} (excluding franking cartridge and AC adapter)

dpm: documents per minute, dpi: dots per inch (25.4 mm)

*1: Indicates the point at which the wear-out failure period starts.

*2: Indicates the mean time between failures during the random failure period.

*3: Indicates the overall mean time between failures, including wear-out and random failures, before the life is reached.

NOTE

- If you connect the scanner via a network, refer to the TM-S1000II-NW Web API Reference Guide.
- The processing speed is not achievable when using USB Full-Speed.

Scanning Specifications

Item		Description
Image scanner		CIS (Contact Image Sensor)
Resolution		200 × 200 dpi
Graduation		Grayscale (256 shades of gray), Black and white
Data compression format	Grayscale	JPEG
	Black and white	CCITT/group 4
Data format	Gray scale	TIFF, JPEG, BMP, Raster, JTIF
	Black and white* ¹	TIFF* ² , BMP
Scanning area		Height: 106 mm {4.17 in.} Length: Up to 235 mm {9.25 in.}
Image quality		Complies with IQA (Image Quality Assurance) formulated by FSTC (Financial Services Technology Consortium).
Skew correction		If the scanner is network-connected, skew correction is performed by the scanner itself.
Auto size adjustment		If the scanner is network-connected, the auto size adjustment is performed by the scanner itself.* ³
Scanning speed		500 mm/s {19.69 in./s}

dpi: dots per inch (25.4 mm)

*1: Image noise reduction is automatically performed by the scanner itself for network connections when digitizing grayscale images.

*2: The TIFF format of resolution 200 dpi, binary, CCITT-Group 4 compression conforms to ANSI X9.100-181-2007.

*3: The image cropping process performed by the scanner itself when the scanner is connected to a network does not include black border processing. Therefore, if the front side of the document has black borders on all four edges, the size of the scanned image may differ between the front and back sides of the document.

The accuracy of the image cropping process is less than ±1.5 mm (the difference between the actual document size and the cropped image size).

Paper Specifications

Item	Description
Type	Normal paper (single-ply only)
Size	Height: 68 to 120 mm {2.68 to 4.72 in.} Length: 120 to 235 mm {4.72 to 9.25 in.}
Thickness	0.075 to 0.2 mm {0.003 to 0.008 in.} (single-ply only)
Weight	60 to 120 g/m ² {16 to 32 lb}

CAUTION

- Make sure that the paper has no curl, folds (especially at the top edges), warps, or wrinkles. Otherwise a paper jam may occur.
- Since the paper sensors use a translucent photo sensor and reflective photo sensor, do not use paper that has holes or translucency at the sensor position as shown in the figures below.

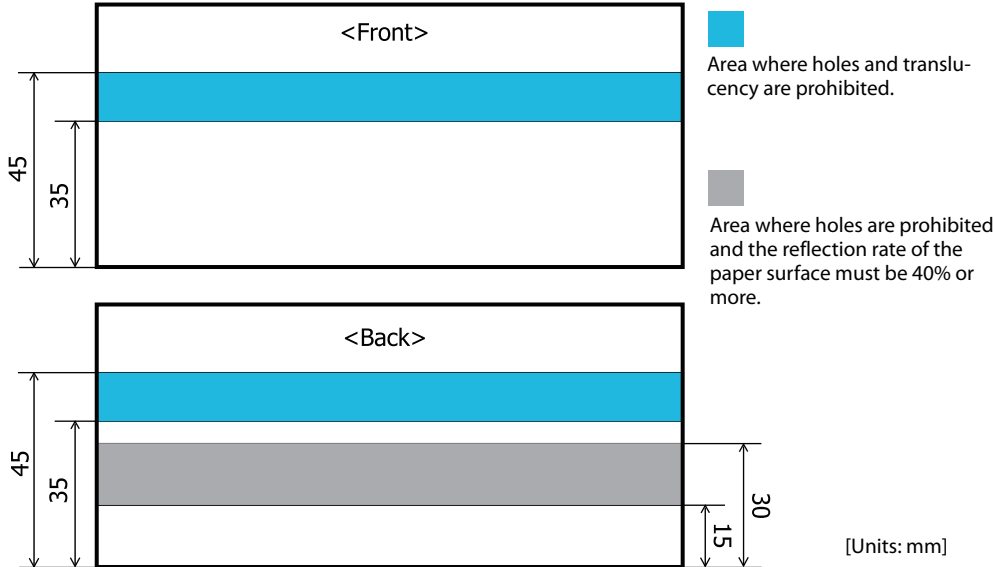

- The paper sensors ignore the range indicated in the figure below for the guide holes in fan-folded paper.

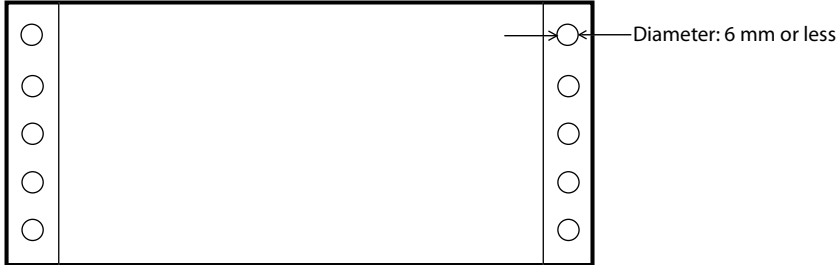

Scannable Area

Image scanning may not be possible in the area a, b, and c in the figures below.

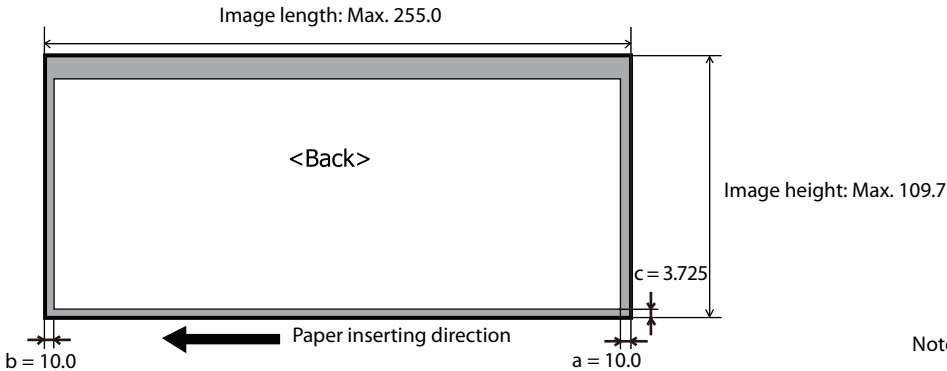
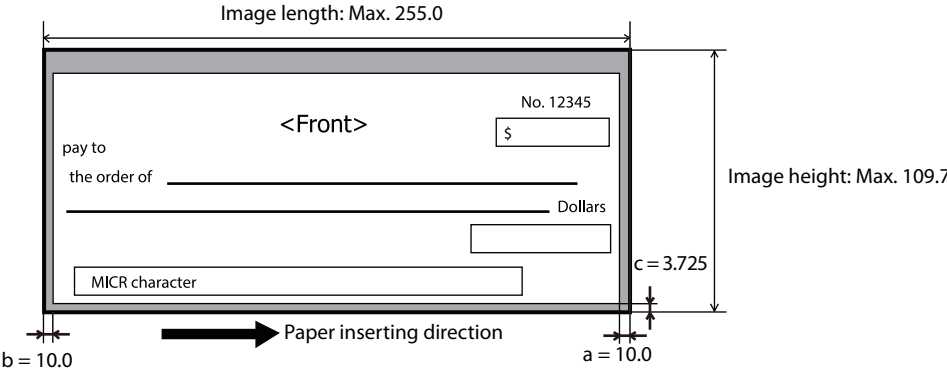

[Units: mm]
Note: Values are typical.

MICR Readable Area

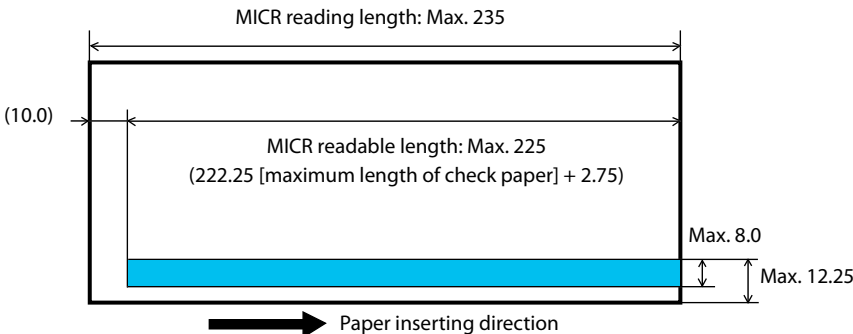

[Units: mm]

Area for Electric Endorsement

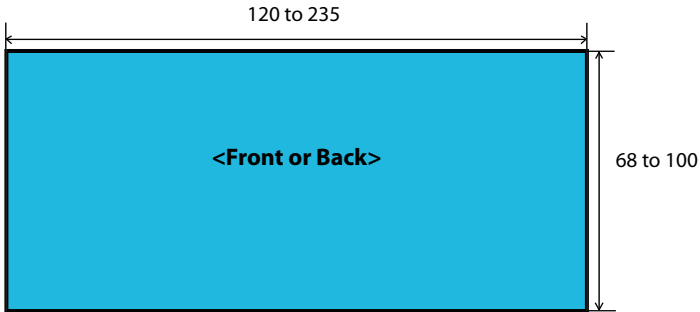

[Units: mm]

Area for Franking

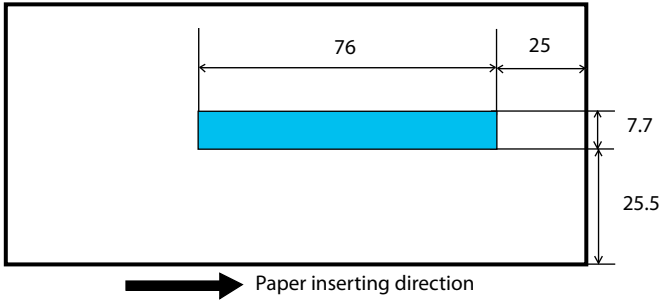

[Units: mm]

Electrical Specifications

Item	Description
Rated input	AC 115 to 230 V/50 to 60 Hz
Input current	1.0 A (max)
Rated output	DC 24 V/1.5 A
AC power consumption (115 to 230 V/50 to 60 Hz)*	Operating: Approx. 25.8 W Ready: Approx. 4.0 W Sleep: Approx. 1.4 W

*According to our operation conditions. It may differ depending on the usage conditions and product model.

Environmental Conditions

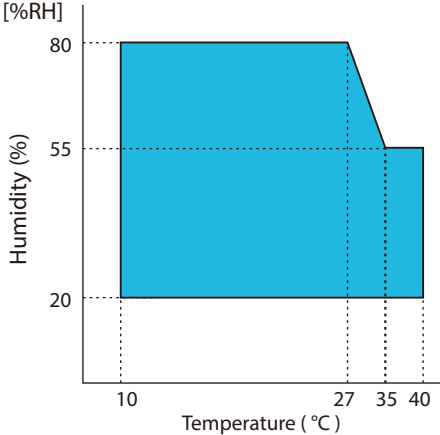
Item	Description
Temperature/ humidity Operating	10 to 40°C {50 to 104°F}, 20 to 80% RH, without condensation (See the graph on the right for operating temperature and humidity range.) 
Storage (Factory packing)	-20 to 60°C {-4 to 140°F}, 5 to 85% RH, without condensation (120 hours or less at -20 {-4°F} or 60°C {140°F})
Vibration resistance When packed	Frequency: 5 to 55 Hz Acceleration: Approx. 19.6 m/s ² {2G} Sweep: 10 minutes (half cycle) Time: 1 hour Orientation: x, y, and z There is no external or internal visible damage and the unit operates normally after being subjected to vibration.
Shock resistance When packed	Packing: Epson standard package specifications Height: 60 cm {23.62 in.} Orientation: 1 corner, 3 edges, and 6 surfaces There is no external or internal visible damage and the unit operates normally after being dropped.
When unpacked	Height: 5 cm {1.97 in.} Orientation: Lift one edge and release it (for all 4 edges) There is no external or internal visible damage and the unit operates normally after being dropped while not operating.
Acoustic noise (operating)	Approx. 57.9 dB (bystander position) Note: The above value was measured under Epson's evaluation conditions. The value varies depending on the paper used, operating conditions (processing mode, processing speed, etc.).
Altitude	3,000 m or less

External Dimensions and Weight

Height: Approx. 176 mm {6.93 in.}

Width: Approx. 355 mm {13.98 in.}

Depth: Approx. 160 mm {6.30 in.}

Weight: Approx. 4.0 kg {8.82 lb}

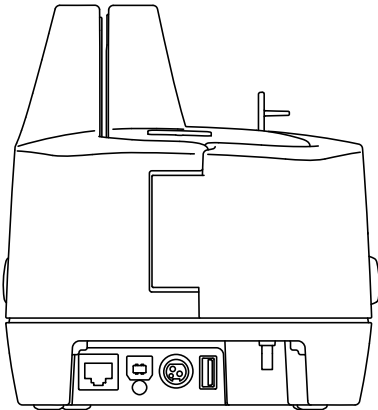
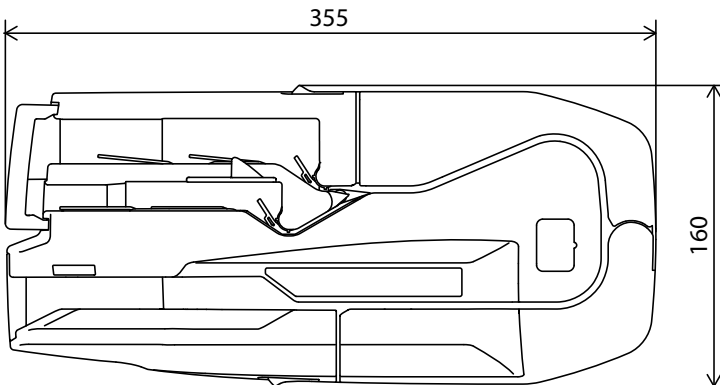
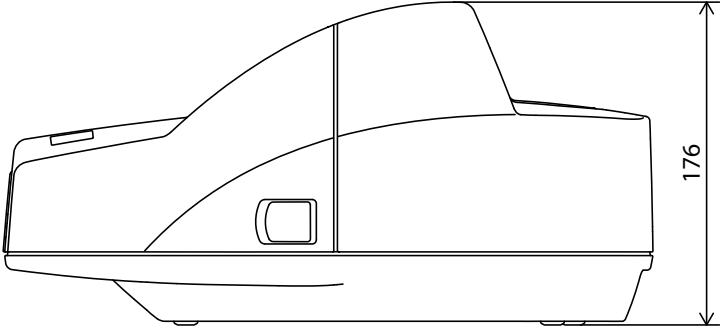

[Unit: mm]

Interface Specifications

USB (type-B) Interface

Item	Description
General specification	USB 2.0
Communication speed	Hi-Speed (480 Mbps) Full-Speed (12 Mbps) The scanner processing speeds described in "Processing Speed" on page 21 cannot be achieved with Full-Speed.
Communication method	USB bulk transmission USB interrupt transmission
Power supply specification	USB self power supply function
USB bus current consumption	Approx. 0.2 mA
Network-USB (Network interfaces via USB)	RNDIS (Model for connecting to Windows computers) CDC-ECM (Model for connecting to macOS computers)

Network Interface Specifications

Support protocols

Protocols	Usage
IP, ARP, ICMP, UDP, TCP	Basic communication protocols
HTTP/HTTPS	Used in Web Config, and Web API
SNMP, ENPC	Used in setting and monitoring
DHCP, APIPA	Used in automatic setting for the IP address and so on

NOTE

- The automatic IP addresses setting is first done using DHCP, and when DHCP is disabled or fails, APIPA is used.
- If the LAN cable is not connected for more than 40 seconds after the product is turned on, the IP address will be automatically set again after the LAN cable is connected.

Network parameters

Item	Initial settings
IP address	192.168.192.168*
Subnet mask	255.255.255.0*
Default gateway	0.0.0.0*
IPv6 Address	Enable*
Acquiring the IP Address (Obtain IP Address)	Auto (DHCP)*
APIPA	Disabled

Item	Initial settings
DNS Server Address Setting	Auto*
Acquire host name automatically	Manual*
Acquire domain name automatically	Manual*
Register the network interface's address to DNS server	Manual*
Administrator Name	None*
Location	None*
Password	The serial number of the scanner*
Socket Timeout	300 seconds
Community name (Read only)	public
Community name (Read/Write)	None
SNMPv3	Disabled
Time Server	Disabled
Time Server Status	Invalid
Time Server Address	0.0.0.0
Bonjour	Enable*
SLP	Enable*
LLTD	Enable*
LLMNR	Enable*
IPsec	Disable*
SSLStrength (Encryption Strength)	128 bit*
https redirect	Enable*

* They are the default values when IP address acquisition is set to "Manual".

For Ethernet interface

Communication specifications

10BASE-T, 100BASE-TX

Network parameters (Ethernet)

Item	Initial settings
Communication mode	Auto negotiation
Port Type	Auto