

TM-T20IV

Technical Reference Guide

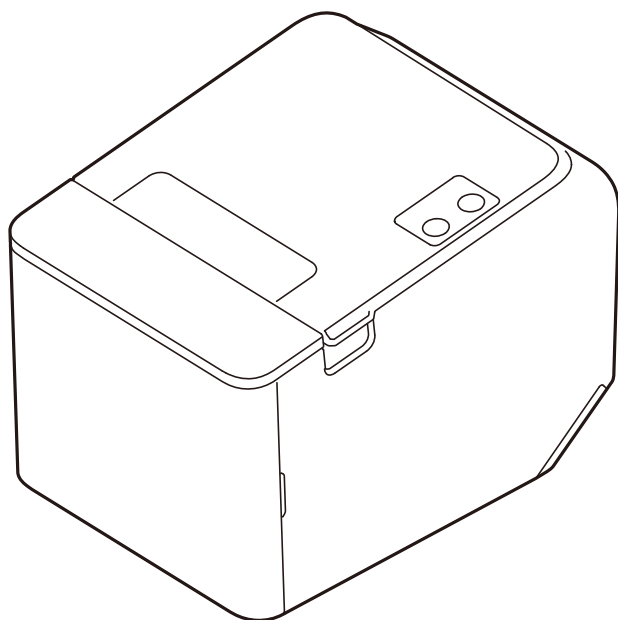

Product Overview

Describes features of the product.

Setup

Describes setup and installation of the product and peripherals.

Advanced Usage

Describes advanced usage methods for the product.

Application Development Information

Describes how to control the printer and necessary information when you develop applications.

Handling

Describes how to handle the product.

Replacement of the TM-T20III

Describes precautions for replacement.

Appendix

Describes general specifications and character code tables.

Cautions

- No part of this document may be reproduced, stored in a retrieval system, or transmitted in any form or by any means, electronic, mechanical, photocopying, recording, or otherwise, without the prior written permission of Seiko Epson Corporation.
- The contents of this document are subject to change without notice. Please contact us for the latest information.
- While every precaution has been taken in the preparation of this document, Seiko Epson Corporation assumes no responsibility for errors or omissions.
- Neither is any liability assumed for damages resulting from the use of the information contained herein.
- Neither Seiko Epson Corporation nor its affiliates shall be liable to the purchaser of this product or third parties for damages, losses, costs, or expenses incurred by the purchaser or third parties as a result of: accident, misuse, or abuse of this product or unauthorized modifications, repairs, or alterations to this product, or (excluding the U.S.) failure to strictly comply with Seiko Epson Corporation's operating and maintenance instructions.
- Seiko Epson Corporation shall not be liable for any damages or problems arising from the use of any options or any consumable products other than those designated as Genuine Epson Products or Epson Approved Products by Seiko Epson Corporation.

Trademarks

Microsoft and Windows are registered trademarks of Microsoft Corporation in the United States and/or other countries.

Wi-Fi®, WPA™, and WPA2™ are either registered trademarks or trademarks of Wi-Fi Alliance®.

IOS is a trademark or registered trademark of Cisco in the U.S. and other countries and is used under license.

Android™ is a trademark of Google LLC.

Google Play and the Google Play logo are trademarks of Google LLC.

QR Code is a registered trademark of DENSO WAVE INCORPORATED in Japan and other countries.

All other trademarks are the property of their respective owners and used for identification purpose only.



ESC/POS Command System

EPSON ESC/POS is a proprietary POS printer command system that includes patented or patent-pending commands. ESC/POS is compatible with most EPSON POS printers and displays. ESC/POS is designed to reduce the processing load on the host computer in POS environments. It comprises a set of highly functional and efficient commands and also offers the flexibility to easily make future upgrades.

For Safety

Key to Symbols

The symbols in this manual are identified by their level of importance, as defined below. Read the following carefully before handling the product.

 WARNING	You must follow warnings carefully to avoid serious bodily injury.
 CAUTION	Provides information that must be observed to prevent damage to the equipment or loss of data. <ul style="list-style-type: none">• Possibility of sustaining physical injuries.• Possibility of causing physical damage.• Possibility of causing information loss.
CAUTION	Provides information that must be observed to avoid damage to your equipment or a malfunction.
NOTE	Provides important information and useful tips.

Warnings

 WARNING	<ul style="list-style-type: none">• To avoid risk of electric shock, do not set up this product or handle cables during a thunderstorm• Never insert or disconnect the power plug with wet hands. Doing so may result in severe shock.• Handle the power cable with care. Improper handling may lead to fire or electric shock.<ul style="list-style-type: none">* Do not modify or attempt to repair the cable.* Do not place any heavy object on top of the cable.* Avoid excessive bending, twisting, and pulling.* Do not place the cable near heating equipment.* Check that the plug is clean before plugging it in.* Be sure to push the plug all the way in.• Be sure to use the specified power source. Connection to an improper power source may cause fire or shock.• Do not place multiple loads on the power outlet. Overloading the outlet may lead to fire.• Shut down your equipment immediately if it produces smoke, a strange odor, or unusual noise. Continued use may lead to fire. Immediately unplug the equipment and contact qualified service personnel.• Never attempt to repair this product yourself. Improper repair work can be dangerous.• Never disassemble or modify this product. Tampering with this product may result in injury or fire.• Do not allow foreign matter to fall into the equipment. Penetration by foreign objects may lead to fire.
---	--



- If water or other liquid spills into this equipment, do not continue to use it. Continued use may lead to fire. Unplug the power cord immediately and contact qualified service personnel.
- Do not use aerosol sprayers containing flammable gas inside or around this product. Doing so may cause fire.

Cautions



- Do not connect cables in ways other than those mentioned in this manual. Different connections may cause equipment damage or fire.
- Be sure to set this equipment on a firm, stable, horizontal surface. The product may break or cause injury if it falls.
- Do not use this product in locations subject to high humidity or dust levels. Excessive humidity and dust may cause equipment damage or fire.
- Do not place heavy objects on top of this product. Never stand or lean on this product. Equipment may fall or collapse, causing breakage and possible injury.
- Take care not to push your hand or finger against the manual cutter. Doing so may injure your hand or finger.
 - * When you remove printed paper
 - * When you perform other operations such as loading/replacing roll paper
- Do not open the roll paper cover without taking the necessary precautions, as this can result in injury from the autocutter fixed blade.
- To ensure safety, unplug this product before leaving it unused for an extended period.
- Do not remove the user interface board installed on this product.



If this product is used in a place where silicon-based gases including siloxane (silicon adhesive, silicon oil, silicon powder, etc.) or malignant gases (nitric acid, hydrogen sulfide, ammonia, chlorine, etc.) are present in the air, contact failure may occur in mechanical contacts such as mechanical switch or DC motor in a short time due to adhesion or oxidation of the insulation film.

Caution Labels

The caution labels on the product indicate the following precautions.



Do not touch the thermal head and the frame on its side during or immediately after use. After printing, the thermal head and its surroundings can be very hot.

Restriction of Use

When this product is used for applications requiring high reliability/safety, such as transportation devices related to aviation, rail, marine, automotive, etc.; disaster prevention devices; various safety devices, etc.; or functional/precision devices, etc., you should use this product only after giving consideration to including fail-safes and redundancies into your design to maintain safety and total system reliability.

Because this product was not intended for use in applications requiring extremely high reliability/safety, such as aerospace equipment, main communication equipment, nuclear power control equipment, or medical equipment related to direct medical care, etc., please make your own judgment on this product's suitability after a full evaluation.

Note About Interference

- This product generates, uses, and can radiate radio frequency energy and, if not installed and used in accordance with the instruction manual, may cause harmful interference to radio communications.
- If this equipment does cause harmful interference to radio or television reception, which can be determined by turning the equipment off and on, the user is encouraged to try to correct the interference by one or more of the following measures:
 - Reorient or relocate the receiving antenna for the radio/TV.
 - Increase the separation between the equipment and the radio/TV.
 - Connect the equipment into an outlet on a circuit different from that to which the receiver is connected.
 - Consult your dealer or an experienced radio/TV technician for help.
- Never disassemble or modify this product.
- Seiko Epson Corporation shall not be liable for interference to radio/TV resulting from changes or modifications to this product not expressly approved by Seiko Epson Corporation.

Open Source Software License

This product uses open source software in addition to Epson proprietary software. For information of the open source software used in this product, see the following URL.

<http://xxx.xxx.xxx.xxx/licenses.html>

For “xxx.xxx.xxx.xxx” in the above URL, input your printer’s IP address.

About this Manual

Aim of the Manual

This manual provides developers/engineers with all the necessary information for design, development and installation of a POS system, and also design and development of a printer application.

NOTE

For Users in Europe, the Middle East and Africa

Models that comply with the cybersecurity requirements of the European Radio Equipment Directive (RED) 2014/53/EU have had changes made to specifications related to network communications, such as enhanced security.

These specification changes affect when using wired LAN, wireless LAN, and Bluetooth with compliant models.

For information on how to identify whether a product is compliant, the specifications of compliant products, and precautions for use, refer to the Cybersecurity Enhancement Supplementary Guide published on the model-specific manual page at the URL below.

[🔗 https://epson.sn](https://epson.sn)

Manual Content

The manual is made up of the following sections:

- Chapter 1 [Product Overview](#)
- Chapter 2 [Setup](#)
- Chapter 3 [Advanced Usage](#)
- Chapter 4 [Application Development Information](#)
- Chapter 5 [Handling](#)
- Chapter 6 [Replacement of the TM-T20III](#)
- Appendix [Product Specifications](#)
[Specifications of Interfaces and Connectors](#)

Contents

■ For Safety	3
Key to Symbols.....	3
Warnings	3
Cautions.....	4
■ Caution Labels	4
■ Restriction of Use	4
■ Note About Interference	5
Open Source Software License	5
■ About this Manual	6
Aim of the Manual	6
Manual Content	6
■ Contents	7
<hr/>	
Product Overview	11
■ Features	11
■ Product Configurations	12
Models.....	12
Accessories	12
■ Parts and Functions	13
LED lights	14
Connectors	15
■ Status and Errors	17
Online and Offline.....	17
Automatically Recoverable Errors	17
Recoverable Errors	18
Unrecoverable Errors	18
Status Display	19
■ NV Memory	20
NV Graphics Memory.....	20
User NV Memory	20
Memory Switches (Customized Value)	20
R/E (Receipt Enhancement).....	20
User-defined Page	21
Maintenance Counter.....	21
■ Simple Setup for Wireless LAN (when OT-WL06 is used)	22
About SimpleAP	23
About Wi-Fi Direct.....	23
■ Useful Functions for Smart Devices.....	24
QR Code.....	24

Setup	25
■ Flow of Setup	25
■ Installing the Printer.....	26
Installing the Printer Vertically	26
Hanging the Printer on a Wall.....	27
■ Adjusting the Roll Paper Near-End Sensor	29
■ Connecting the AC adapter.....	30
Connecting Procedure	30
■ Connecting the Printer to the Host	31
USB Interface	31
Serial Interface	31
Ethernet Interface	32
Wireless LAN Interface (when OT-WL06 is used)	33
■ Connecting the Cash Drawer	39
Cash Drawer Requirements	39
Connecting the Drawer Kick Cable.....	40
■ Connecting the Optional External Buzzer.....	41
Connecting Procedure	41
■ Connecting the Optional Wireless LAN Unit.....	43
■ Changing the Paper Width	44
<hr/>	
Advanced Usage	45
■ Software Settings.....	45
Overview of Each Function.....	46
■ Setting/Checking Modes	52
Self-test Mode	54
NV Graphics Information Print Mode.....	54
Receipt Enhancement Information Print Mode	55
Software Setting Mode	55
Restore Default Values Mode.....	57
Interface Setup Mode.....	59
Peripheral Device Information Print Mode	60
Hexadecimal Dumping Mode	61
■ Printing a Status Sheet.....	62
■ Resetting the Interface Settings	64
■ Web Config.....	65
How to Start Web Config.....	65
What can be Configured in Web Config	65

Application Development Information..... 66

■ Controlling the Printer	66
ePOS-Print XML.....	66
ESC/POS	66
■ Controlling the Cash Drawer.....	67
■ Controlling the Optional External Buzzer	68
■ Software.....	69
Development Kits	69
Drivers	70
Utilities	71
Others.....	71
Download	71
■ Precautions when Developing Applications	72
Power Button Settings	72
Notes on Printing Barcodes and Two-dimensional Symbols	72
■ Automatic Certificate Update Feature	74
Overview	74
Implementation.....	75
Operation Check.....	76

Handling 77

■ Installing and Replacing Roll Paper.....	77
■ Removing Jammed Paper	79
When the Roll Paper Cover Cannot be Opened.....	79
■ Cleaning the Printer	81
Cleaning the Printer Case.....	81
Cleaning the Thermal Head/Platen Roller.....	81
■ Preparing for Transport	82
■ Checking the Nameplate	82
■ Precautions when Using the Printer as a Self-Service Terminal.....	83

Replacement of the TM-T20III..... 84

■ Compatibility	84
Printing	84
Logo Registration.....	84
Driver Compatibility.....	84
If Connecting as a Peripheral Device of the TM-i/DT Printer	84
Overall Dimensions	85

Appendix..... 86

■ Product Specifications 86

Printing Specifications87
Character Specifications88
Paper Specifications89
Printable Area90
Printing and Cutting Positions92
Electrical Characteristics93
Environmental Conditions94
External Dimensions and Weight95

■ Specifications of Interfaces and Connectors 96

USB Interface96
RS-232 Serial Interface97
Network Interface 101
Default administrator password for setting 106

Product Overview

This chapter describes features of the product.

Features

Printing

- High speed receipt printing is possible (250 mm/s {9.84 in./s} maximum).
- Switching from 80 mm {3.15 in.} width paper printing to 58 mm {2.28 in.} width paper printing is available.

Handling

Easy drop-in paper loading

Software

- Command protocol is based on the ESC/POS Proprietary Command System.
- Windows printer drivers, OPOS ADK, and OPOS ADK for .NET are available.
- Printing of various types of bar codes, GS1-DataBar, and two-dimensional symbols (PDF417, QR code, MaxiCode, Composite Symbology, Aztec Code, DataMatrix) is supported.
- A maintenance counter function is supported.
- Multiple languages are supported for code pages, Windows drivers, and utility software.

Interface

The interface is selectable when purchasing the product.

Environment

Paper reduction function is available.

Others

- Various installation layouts (horizontal, vertical, and wall-hanging installation) are selectable.
- Optional Wireless LAN unit and external buzzer are available.

Product Configurations

Models

- USB/Serial
- USB/Ethernet/Serial

Accessories

Included

- Roll paper (for operation check)
- Wall hanging bracket
- Rubber feet for vertical installation
- 58 mm {2.28 in.} width roll paper guide
- AC adapter
- USB interface cable
- AC cable*
- User's Guide



*: Not included with some models

Options

- Affixing tape for fixing the printer (Model: DF-10)
- External buzzer (Model: OT-BZ20)
- Wireless LAN cable set (Model: OT-WL06)

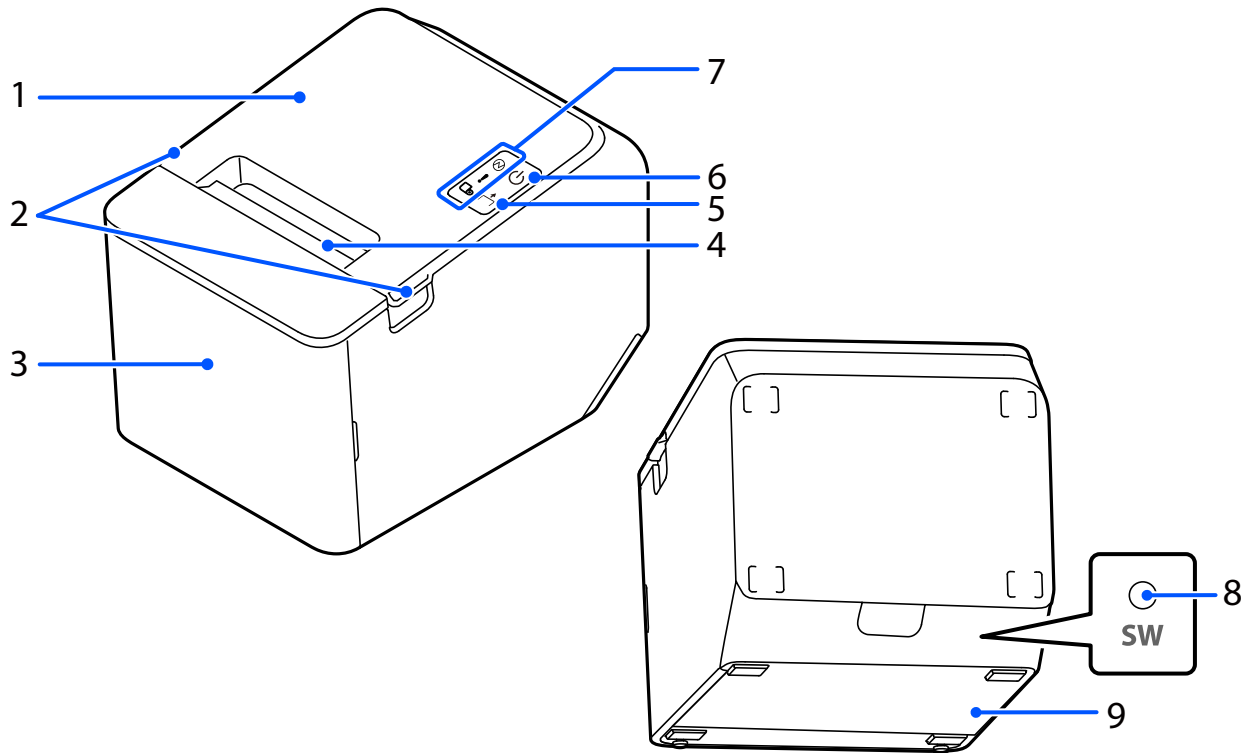
Parts and Functions







1	Roll paper cover	Open this cover to install/replace the roll paper.
2	Cover knob	Put your finger under the knob and lift open the roll paper cover.
3	Cutter cover	If the roll paper cover will not open due to a paper jam, open this cover and unlock the autocutter blade.
4	Manual cutter	Use this cutter when you cut the roll paper manually.
5	 Feed button	Press this button to feed the roll paper by one line. Hold down this button to feed the roll paper continuously.
6	 Power button	Press this button to turn the printer on or off.
7	LED lights	For details on the LED lights, see "LED lights" on page 14 .
8	Status sheet button (USB/Ethernet/Serial model only)	Press this button to print the interface status sheet, or to reset the interface settings.
9	Connector cover	Use the printer with this cover attached to protect cables.

NOTE

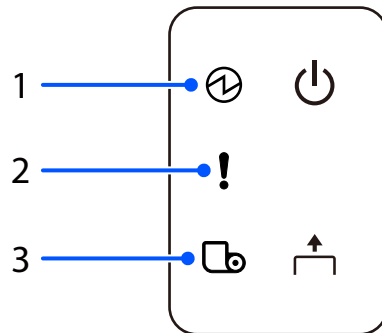
When turning off the printer without using the power switch, it is recommended to send a power-off command to the printer. If you use the power-off sequence, the latest maintenance counter values are saved. (Maintenance counter values are usually saved every two minutes.) For information about ESC/POS commands, see the ESC/POS Command Reference.

LED lights







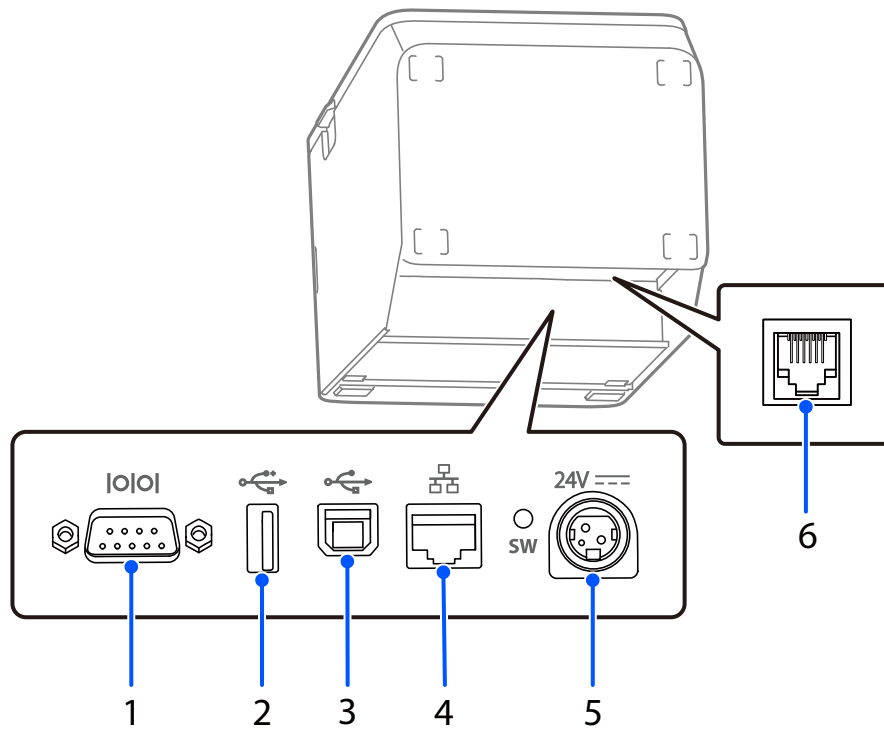

1	 Power LED	<ul style="list-style-type: none"> • On when the printer is powered on. • Off when the printer is powered off.
2	 Error LED	<p>Lights or flashes when the printer is offline. (For information about the lighting and flashing patterns, see "Status and Errors" on page 17.)</p> <ul style="list-style-type: none"> • Lights after the power is turned on or after a reset (offline). Automatically goes out after a while to indicate that the printer is ready. • Lights when the end of the roll paper is detected, and when printing has stopped (offline). If this happens, replace the roll paper. • Off when the printer is in standard mode (online).
3	 Paper LED	<ul style="list-style-type: none"> • Lights when there is no more roll paper. If the near-end detection is set to "Enabled", this LED also lights when the near-end of the paper is detected. • Off when there is a sufficient amount of roll paper remaining. • Flashes when a self-test is in progress or when macro execution standby state.

Connectors

All connectors are located on the lower rear of the printer. The interface installed differs according to the model.

USB/Ethernet/Serial model







1	 Serial interface	Serial interface cable connector for connection to computer.
2	 USB connector (Type-A)	Use only for connecting optional Wireless LAN unit.
3	 USB connector (Type-B)	USB cable connector for connection to computer.
4	 Ethernet connector	Ethernet cable connector for wired network connection to computer.
5	 24V --- Power supply connector	DC cable connector. "Connecting the AC adapter" on page 30
6	 Drawer kick connector	Cashdrawer connector or optional external buzzer connector. "Connecting the Cash Drawer" on page 39 "Connecting the Optional External Buzzer" on page 41

USB/Serial model

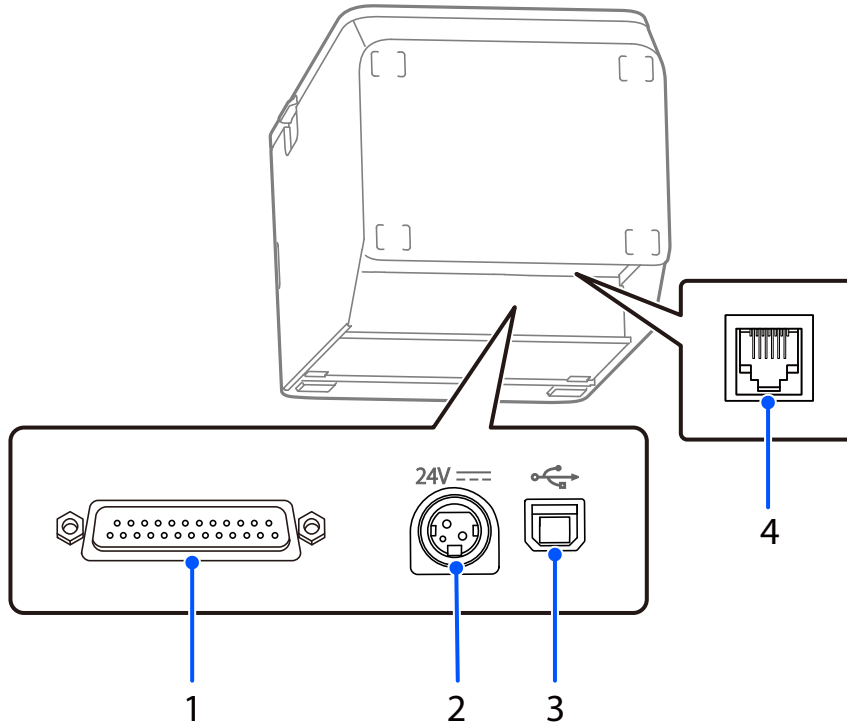
CAUTION

Do not remove the interface board installed on this product.



1	Serial interface	Serial interface cable connector for connection to computer.
2	24V  Power supply connector	DC cable connector. "Connecting the AC adapter" on page 30
3	 USB connector (Type-B)	USB cable connector for connection to computer.
4	 Drawer kick connector	Cashdrawer connector or optional external buzzer connector. "Connecting the Cash Drawer" on page 39 "Connecting the Optional External Buzzer" on page 41

Status and Errors

The LEDs light or flash to indicate the printer status.

CAUTION

The printer cannot print while an error is left unsolved.

Online and Offline

Online

The printer is online and ready for normal printing unless there is a reason to go offline.

Offline

The printer automatically goes offline under the following conditions:

- While the printer power is turning on/off
- While a self-test is running
- While roll paper is fed using the Feed button
- When the printer stops printing due to a paper end
(When the paper end is detected by the roll paper end sensor)
- During an operation standby state
- When an error has occurred ("[Status and Errors](#)" on page 17)
- While the roll paper cover is open

Automatically Recoverable Errors

The printer cannot print when automatically recoverable errors occur. When the conditions for recovery described below are met, the printer automatically recovers from the error.

Error	Error description	Error LED status	Condition for Recovery
Roll paper cover open error	The roll paper cover was opened during printing	ON	The roll paper cover is closed
Head temperature error	A high temperature outside the thermal head drive operating range was detected	ON	When the thermal head cools
Motor driver IC high temperature error	A high temperature beyond the standard range for driving the motor is detected.	ON	The printer recovers from the error after the elapse of a certain period of time.

Recoverable Errors

The printer cannot print when a recoverable error occurs. When the roll paper cover is closed, the power is turned off and on again, or an error recovery command is received, the printer can recover from the error.

Error	Error description	Error LED status	Condition for Recovery
Autocutter error	Autocutter does not work correctly	ON	Recovers from the error when the jammed paper or foreign matter is removed, and the roll paper cover is closed

CAUTION

The error recovery command is valid only if a recoverable error (excluding automatically recoverable errors) occurs.

NOTE

Use the TM-T20IV Utility to change the condition for recovery. For details, see the TM-T20IV Utility User's Manual.

Unrecoverable Errors

The printer cannot print when an unrecoverable error occurs. If the error persists after turning the printer off and then on again, the printer may require service. Contact qualified service personnel.



CAUTION

Turn off the power immediately when an unrecoverable error occurs.

Error	Error description	Error LED flash code
R/W error in memory	After R/W checking, the printer does not work correctly.	
High voltage error	The power supply voltage is extremely high.	
Low voltage error	The power supply voltage is extremely low.	
CPU execution error	The CPU is executing an incorrect address.	
Internal circuit connection error	Internal circuits are not connected correctly.	
Communication unit error	An error has occurred in the communication unit. (USB/Serial model only)	

Status Display

●: ON ●: Flashing ○: OFF -: Changes depending on whether or not paper is detected.

	Power LED	Error LED	Paper LED
Online	●	○	○
Initializing after power-on	●	●	●
Running a self-test	●	○	-
Waiting to continue self-test	●	○	●
Feeding using the Feed button	●	○	-
Waiting to execute a macro	●	○	●
Roll paper cover open while the printer is not printing	●	●	-
No paper	●	●	●
While updating firmware	●	●	●
While in forced firmware update mode	●	●	●
While in power off standby	●	○	●
The network link is down	●	○*	-
Waiting to print status sheet	●	●	●

*: In firmware versions earlier than 30.11 ESC/POS, the error LED blinks if the device is not connected to the network. The error LED flashing patterns are as follows.

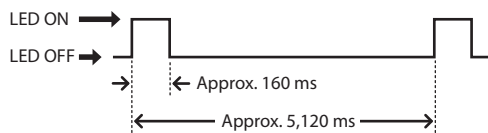

In firmware version 30.11 ESC/POS and later, the error LED does not blink if the device is not connected to the network. To check the network connection status, please check the LED on the Ethernet connector.

["For Ethernet interface" on page 103](#)

NV Memory

The printer is equipped with the NV memory (Nonvolatile Memory) to store data even after the printer power is turned off. NV memory contains the following memory areas for the user:

- NV graphics memory
- User NV memory
- Memory switches (Customized value)
- R/E (Receipt Enhancement)
- User-defined page
- Maintenance counter



Epson recommends that changes to NV memory be performed no more than 10 times a day, if any.

NV Graphics Memory

Graphics, such as shop logos to be printed on receipts, can be stored. Even with a serial interface model whose transmission speed is low, high speed graphics printing is possible.

TM-T20IV Utility or ESC/POS commands can be used for the graphic registration.

TM-T20IV Utility or NV Graphics Information Print Mode can be used for the confirmation.

User NV Memory

You can store and read text data for multiple purposes, such as for storing a note including customizing or maintenance information of the printer.

Memory Switches (Customized Value)

You can configure various settings of the printer.

For more information, see "[Software Settings](#)" on page 45.

R/E (Receipt Enhancement)

Registered graphics in the NV Graphics Memory can be printed automatically, as a top logo before receipt printing or as a bottom logo before cutting paper.

TM-T20IV Utility or ESC/POS commands can be used for the settings.

TM-T20IV Utility or Receipt Enhancement Information Print Mode can be used for the confirmation.

User-defined Page

You can store character data in the user-defined page (character code table: page 255) so that you can also print characters not resident in the printer.

Maintenance Counter

With this function, printer information, such as the number of lines printed, the number of paper autocuts, and printer operation time after the printer starts working, is automatically stored in NV memory. You can use the counter information for periodical maintenance checks or part replacement.

NOTE

- You can also check the print head running length and number of times of auto-cutting with the self-test (see "[Self-test Mode](#)" on page 54).
- The maintenance counter value is normally saved in the NV memory every 2 minutes (maximum of 4 minutes). However, it is not automatically saved when the product is in the power-saving mode or when the power is turned off without using the power switch.

Simple Setup for Wireless LAN (when OT-WL06 is used)

The printer has "SimpleAP" mode that allows a device to directly connect to the printer without using an access point. This makes it easy to set up a printer to connect to a wireless LAN using the printer setting tool, without having to go through a network environment such as an access point.

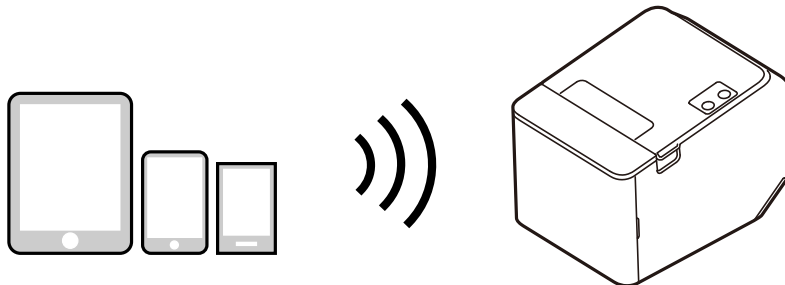

When all of the following conditions are met and the printer is turned on, SimpleAP will start automatically. After startup, a "SimpleAP Start" sheet will be printed.

- No USB cable is connected
- No LAN cable is connected
- SSID and passphrase are not set
- Wireless LAN unit is connected

"SimpleAP Start" sheet



If SimpleAP does not start automatically (the "SimpleAP Start" sheet is not printed), start SimpleAP from the menu that can be selected after printing the status sheet guidance ("[Setting up using Web Config](#)" on page 34) or from the interface setup mode ("[Interface Setup Mode](#)" on page 59).

If you have changed the wireless LAN connection settings from the default settings for your environment and devices, start according to those settings and connect to the access point.

About SimpleAP

- Use SimpleAP to change the printer's wireless LAN connection settings.
- The printer acts as an access point in the SimpleAP mode and allows up to eight devices to connect to the printer. However, devices directly connected to the printer cannot communicate with each other through the printer.
- Do not use 172.16.x.x for the IP address of the wireless LAN and wired LAN because the default IP address of SimpleAP is 172.16.10.1. If used, SimpleAP will be stopped to avoid IP address conflicts. If SimpleAP is restarted in the above state, the initial IP address of SimpleAP will be changed to 192.168.223.1 to avoid IP address conflicts.
- Even if you have not changed your passphrase, you may be prompted to enter your passphrase. For information about the default passphrase, see "[Default administrator password for setting](#)" on page 106.
- If SimpleAP is started when the printer is connected via wireless LAN, the wireless LAN connection is temporarily disconnected.

About Wi-Fi Direct

- Use Wi-Fi Direct to connect the host and printer directly over a wireless LAN for printing without using an access point.
- The printer acts as an access point in the Wi-Fi Direct and allows up to eight devices to connect to the printer. However, devices directly connected to the printer cannot communicate with each other through the printer.
- The printer can be connected to Wi-Fi Direct and a wireless LAN or a wired LAN at the same time.
- Wi-Fi Direct settings can be checked or changed using Web Config or TM-T20IV Utility. For details, check the Web Config Reference Guide or the TM-T20IV Utility User's Manual.

Useful Functions for Smart Devices

You can easily connect this product to the network by using the QR code printed on the status sheet.

QR Code

Capture the QR code printed on the status sheet with the camera on your smart device to acquire the printer information (information for specifying the device).

By using the acquired information, the device can specify the printer to send a print job over a network or Bluetooth.

NOTE

- Programming using Epson ePOS SDK is required to use these functions. These functions are created by combining NFC touch and QR code capturing operations and the target printer specifications using Printer Easy Select API. See the "Epson ePOS SDK for Android/iOS User's Manual" and the Epson ePOS SDK sample program for more details. The sample program also contains a sample implementation method for reading an NFC tag and capturing a QR code.
- You can try a demo of these functions by using Epson TM Utility.

Setup

This chapter describes setup and installation of the product and peripherals.

Flow of Setup

This chapter consists of the following sections along with the setup flow of the product and peripherals.

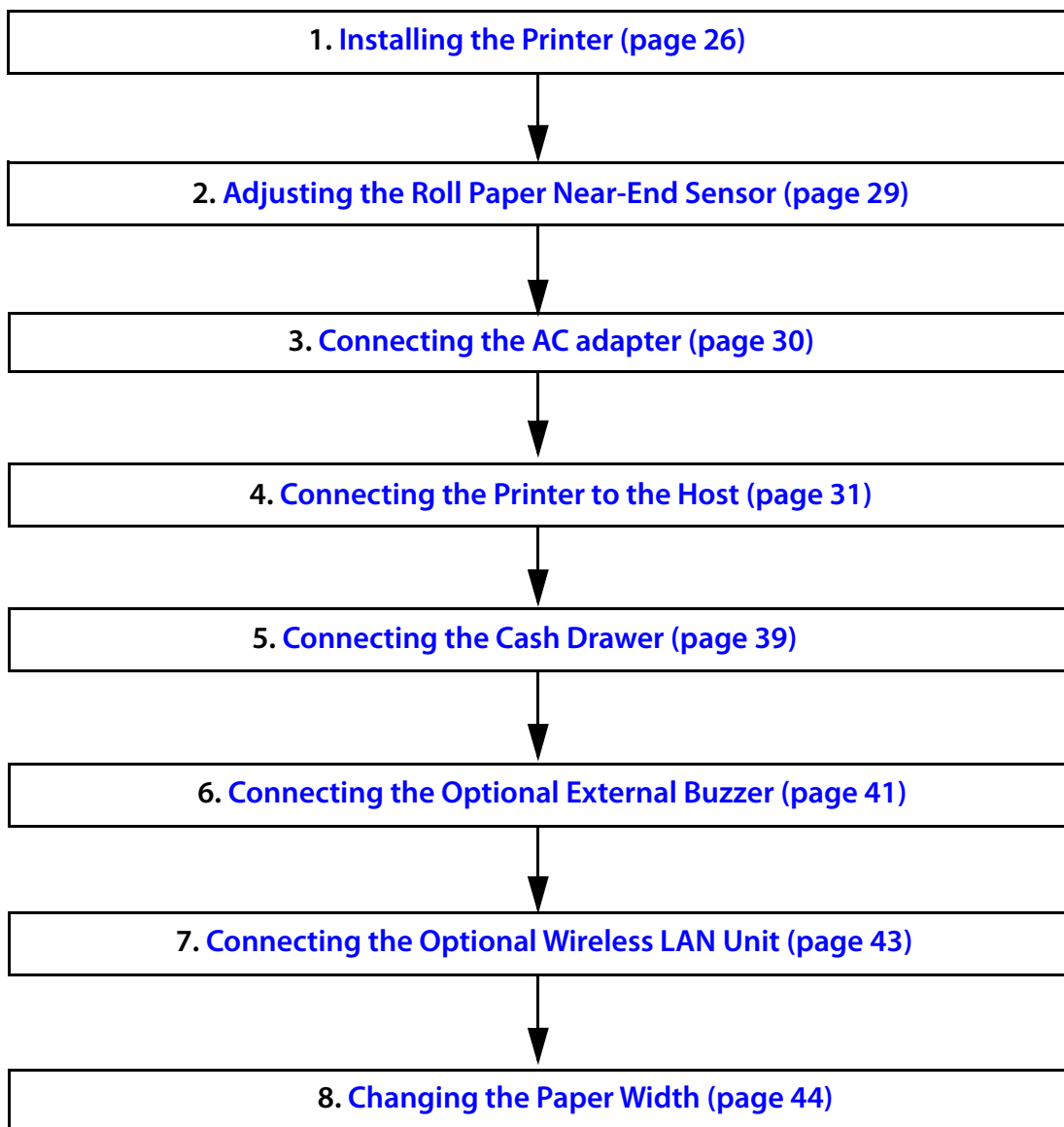

Installing the Printer

You can install the printer horizontally on a flat surface (with the paper exit on top) or vertically (with the paper exit at the front). Also, you can hang it on a wall using the included accessories.

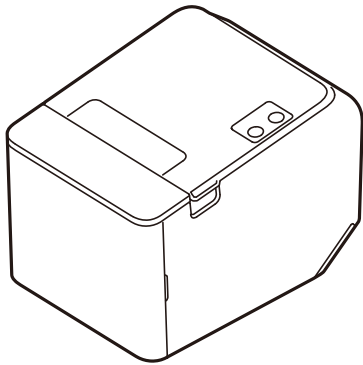

Horizontal installation

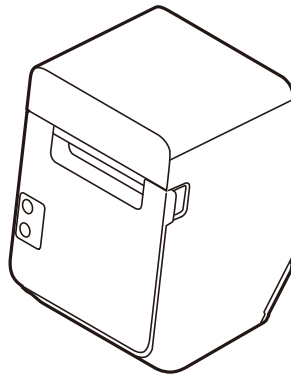

Vertical installation

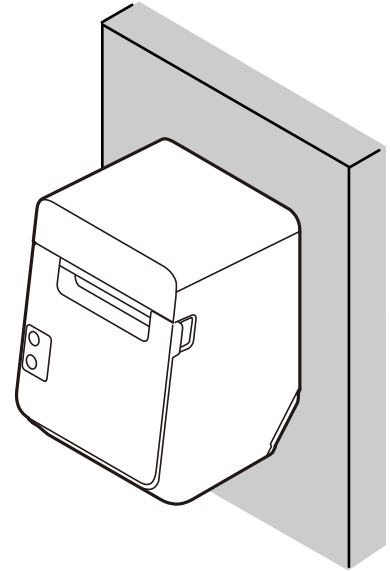

Hanging on a wall

CAUTION

- Do not place the printer in a dusty location.
- Do not knock or strike the printer. This may cause defective print.
- Do not catch cables or place foreign matter under the printer.
- Take measures to prevent the printer from moving by vibration during paper cutting and when using a drawer. Affixing tape (Model: DF-10) is provided as an option.

Installing the Printer Vertically

When installing the printer vertically, attach the four rubber feet in the rectangular indents in the printer case, as shown in the illustration below.

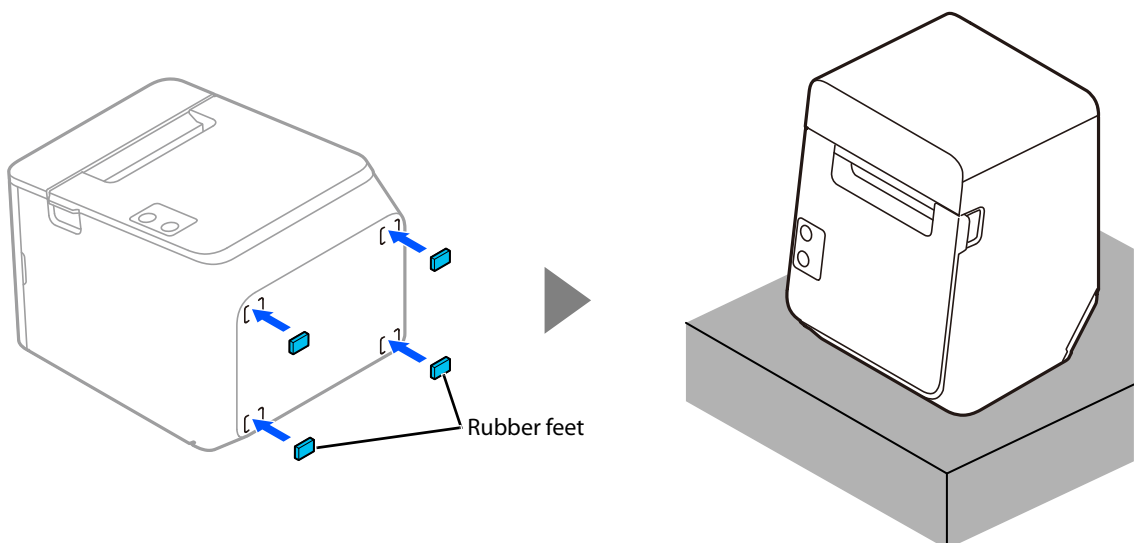

Hanging the Printer on a Wall

To securely hang the printer on a wall, follow the steps below.

CAUTION

- Hang the printer on a wood, concrete, or metal wall. The thickness of the wall should be 10 mm {0.4 in.} or more.
- Be sure to use metallic screws.
- The screws to be put into the wall must have a pull-out strength of 150 N (15.3 kgf) or more.

1 Put two screws (diameter: 4 mm {0.16 in.}, head diameter: 7 to 9 mm {0.28 to 0.35 in.}) into the wall at an interval of 80 mm {3.15 in.}.

Make sure the length of the screw in the wall is 10 mm {0.39 in.} or more, and the length outside the wall is 3 to 4 mm {0.12 to 0.16 in.}.

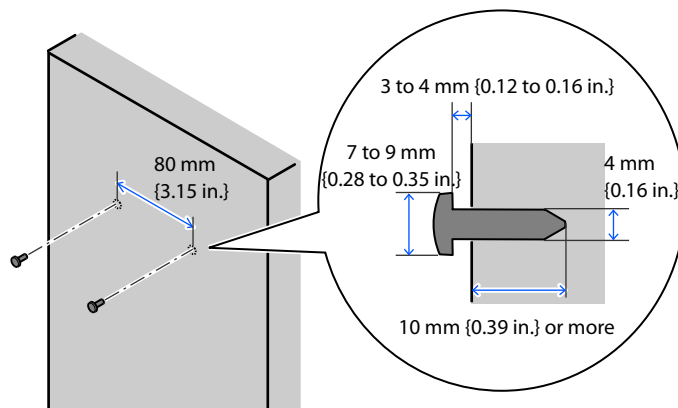

2 Remove the two screws from the printer, and then attach the wall hanging bracket to the printer using the screws.

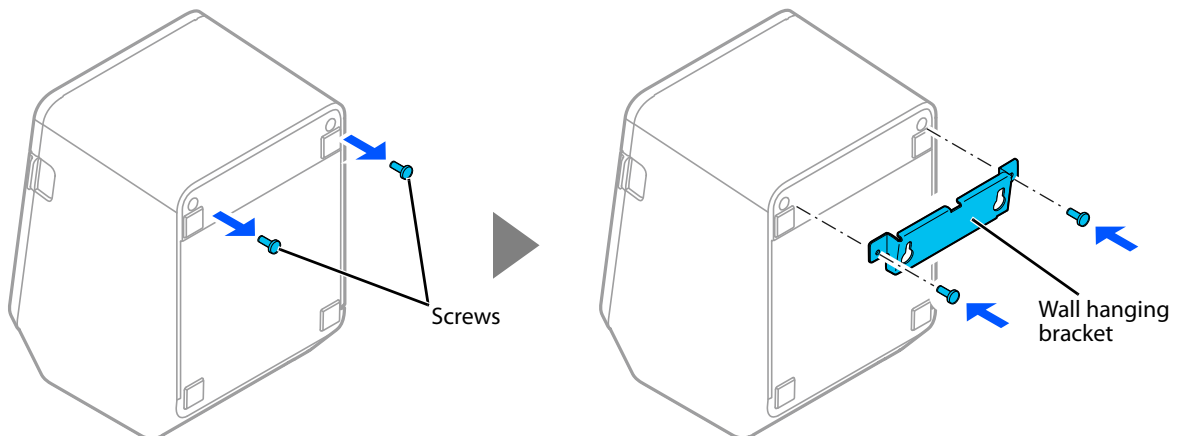

- 3** Align the holes in the wall hanging bracket with the screws on the wall, and hook it securely.

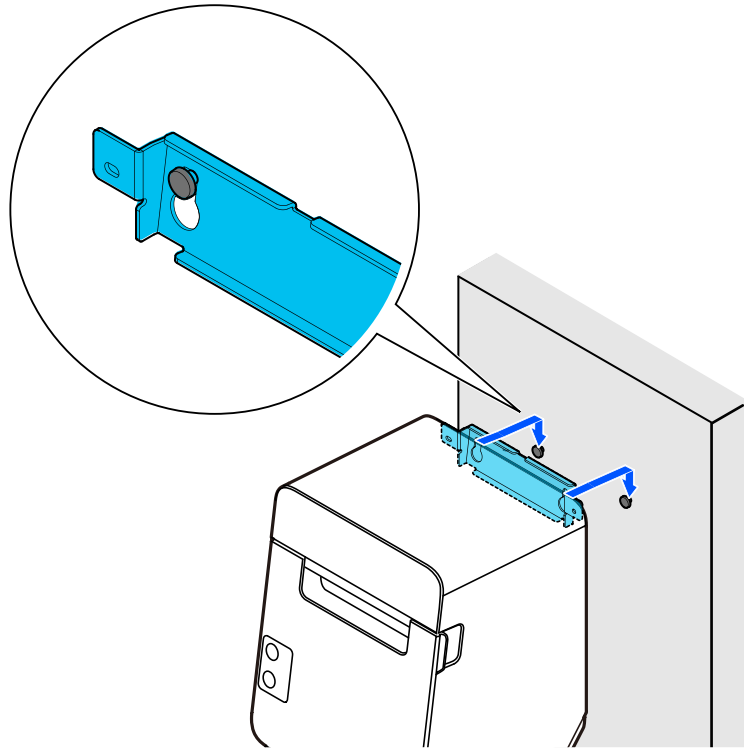

Adjusting the Roll Paper Near-End Sensor

Below are two situations where a roll paper near-end sensor adjustment is required.

- To adjust the detection position to suit the diameter of the roll paper core used.
- To adjust the detection position of remaining amount of paper.

CAUTION

- The roll paper near-end detection function can be used only when this product is installed horizontally.
- Be sure to disable the near-end detection when the product is installed vertically or is wall-mounted. Failure to do so may lead to erroneous detection.
- Since roll paper cores vary slightly in shape, depending on paper roll design and manufacturing tolerances, it is impossible to detect the remaining paper exactly.
- Use roll paper with a core inner diameter of 12 mm {0.47 in.} and outer diameter of 18 mm {0.71 in.} so that the near-end sensor can detect the remaining paper as accurately as possible.
- To use the near-end detection, it must be enabled using the memory switches. See "[Software Setting Mode](#)" on page 55 for details about the making the memory switch settings.

Follow the steps below to adjust the roll paper near-end sensor.

- 1 Open the roll paper cover, and remove the roll paper.
- 2 Loosen the adjustment screw fastening the sensor, and align the upper edge of the positioning plate with the adjustment position.

Adjustment position	Remaining amount of paper (outer diameter)
Upper	Approx. 27 mm {1.06 in.}
Lower (Default setting)	Approx. 23 mm {0.97 in.}

- 3 Tighten the adjustment screw.
- 4 After adjustment, make sure that the detection lever operates smoothly.

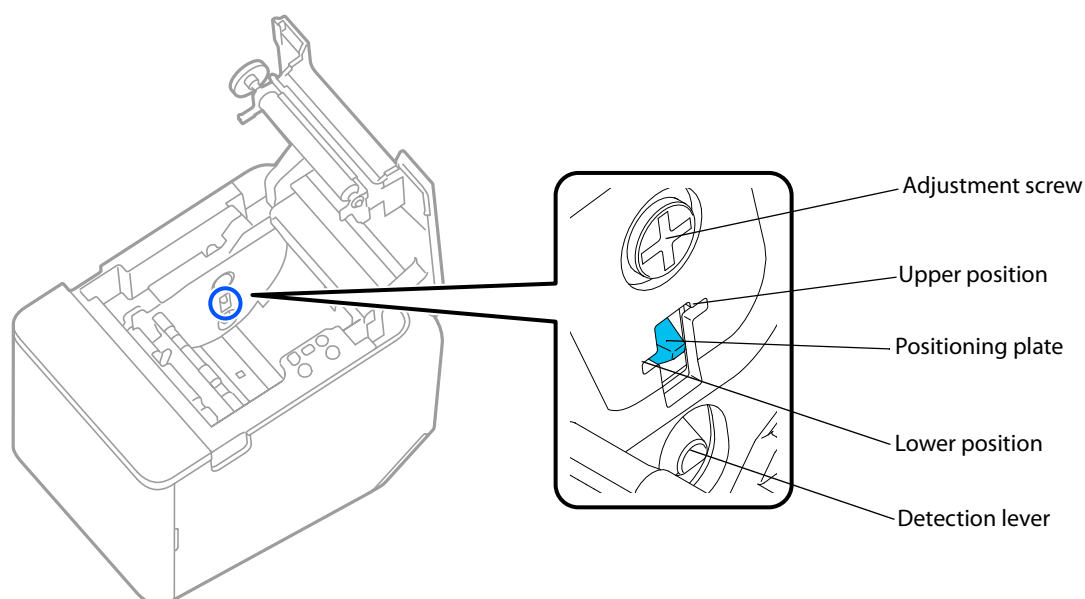

Connecting the AC adapter

Use the Epson AC adapter, C1 or an equivalent product as the AC adapter.



- Never insert the AC cable plug into a socket that does not meet the input voltage of the AC adapter. Doing so may result in damage to the printer.
- Should a fault ever occur, immediately turn off the power to the printer and unplug the AC cable from the wall socket.

Connecting Procedure

- 1** Make sure the printer is turned off.
- 2** Connect the AC cable to the AC adapter.

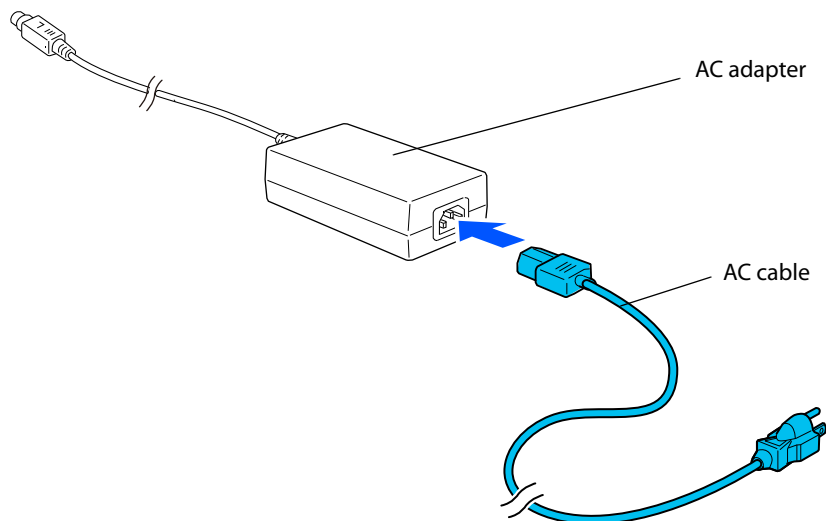

- 3** Connect the DC cable of the AC adapter to the power supply connector (stamped 24V).

Connecting the Printer to the Host

CAUTION

- Be sure to install the driver before connecting the printer to the host computer.
- The DK connector specifically designed for use with a cashdrawer or the optional external buzzer. Do not connect this connector into a wired telephone system.

USB Interface

When using USB cable to connect with host device, connect the USB cable to the printer, and after starting the host device, turn the printer on.

When connecting the USB cable to the printer, fix the cable with the hook to prevent it from being disconnected.

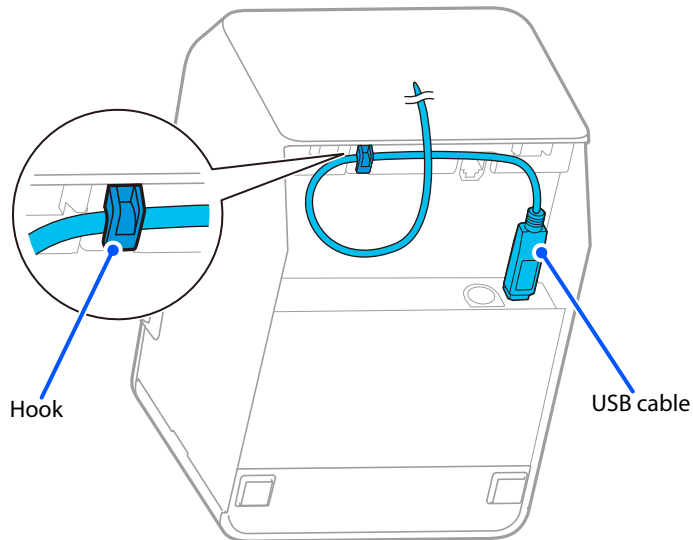

CAUTION

Do not place any weight or stress on the cable when using. Doing so could damage the cable and connectors.

Serial Interface

When connecting to the host computer through a serial interface (RS-232), connect a serial cable to the printer, start the host computer, and then turn on the printer.

NOTE

When using connectors equipped with screws, tighten the screws on both sides to secure the connectors firmly.

Ethernet Interface

Use an Ethernet cable to connect the printer to network via a hub.

Use Epson TM-T20IV Utility or Web Config to set network.

For detailed information about the Epson TM-T20IV Utility, refer to the TM-T20IV Utility User's Manual.

For details on Web Config, refer to Web Config Reference Guide.

CAUTION

- When LAN cables are installed outdoors, make sure they are connected through devices that have surge protection. Otherwise, the devices can be damaged by lightning.
- Do not connect a telephone cable or a cashdrawer cable into the LAN port connector. Only connect ethernet LAN cables to this connector.

Wireless LAN Interface (when OT-WL06 is used)

You can connect using a wired cable (LAN/USB), or connect using SimpleAP mode, and setup a wireless LAN using a network configuration tool. When setting up multiple printers, you can connect using a wired cable (LAN/USB) and setup a wireless LAN using the Epson Deployment Tool.

Using Epson TM Utility for iOS/Android, you can easily connect the printer to the network from an iOS or Android devices.

CAUTION

- When using wireless LAN, make sure you disconnect the LAN cable. If a LAN cable is connected, wireless LAN is disabled.
- When you set up the access point at the same time, set the access point in advance and check that it operates correctly.
- Examine the radio wave situation in the surrounding area before use.
- Avoid using the same channel that is used in the neighboring shops where Wireless LAN is used.
- When using the printer in environments where kitchen microwaves and other devices that may interfere radio waves are installed, observe the following points.
 - * Keep the printer away from the devices, such as kitchen microwaves, that may cause radio wave interference.
 - * Use channels that are away from the frequency bands that may cause radio wave interference.
 - * Place shields between the printer and the devices that may cause radio wave interference.
 - * Select either 2.4 GHz or 5 GHz, whichever is free from radio wave interference.
 - * In auto channel setting for the access point, do not select a channel in which the devices may cause radio wave interference.

NOTE

For SimpleAP mode, see ["Simple Setup for Wireless LAN \(when OT-WL06 is used\)" on page 22.](#)

Setting up using Web Config

How to set up using Web Config is also introduced in the video manual.

You can access the manual from the URL below.

 https://support.epson.net/p_doc/a5d/

Necessary Items

Prepare the following items.

A device for the setup which has a web browser.

When the printer is turned on during the following conditions, the SimpleAP mode is automatically activated and the “SimpleAP Start” sheet and guidance are printed. In this case, start the setup from step 4.

- No USB cable is connected
- No LAN cable is connected
- SSID and passphrase are not set
- Wireless LAN unit is connected

Setup Procedure

1 Open the roll paper cover of the printer, and then hold down the Feed button until the paper LED starts flashing, then release the button.

2 Close the roll paper cover.

A guidance that starts with “Next Action” will be printed.

3 Press the Feed button five times briefly (less than one second each), then press and hold the button for more than one second.

“SimpleAP was selected. Release the Feed button.” guidance will be printed, followed by a “SimpleAP Start” sheet.



4 Scan the QR code on the “SimpleAP Start” sheet with the device for setup and connect it to the printer.

If the device cannot scan the QR code, open the Wi-Fi settings screen of the device, select the SSID printed on the “SimpleAP Start” sheet, and enter the password to connect. For information about the default password, see [“Default administrator password for setting” on page 106](#).

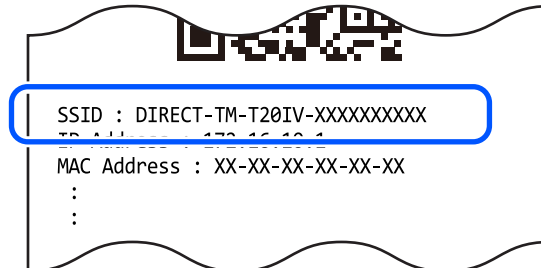

Once connected to the printer, guidance will be printed to start Web Config.



Depending on the device you are using, Web Config will start automatically.

5 If Web Config does not start automatically after connecting to the printer, scan the QR code in the guidance that says “WebConfig Start” at the beginning.

If the device cannot scan the QR code, start the device’s web browser and enter the IP address of the printer in the address field.

The IP address is written on the “SimpleAP Start” sheet.

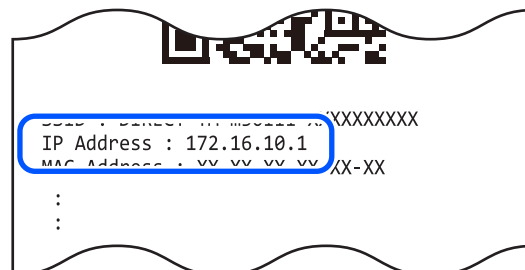

6 When the Web Config screen opens, select the “Wi-Fi” menu.

- 7 Enter the password and select [OK] to log in to Web Config.**
For information about the default password, see "[Default administrator password for setting](#)" on [page 106](#).
- 8 From the list of SSIDs displayed, select the SSID of the network you want to connect to and select [OK].**
- 9 Enter your network password and select [OK].**
When the IP address is printed, the connection is complete.

Setting up using a USB Connection from a Windows Computer

Necessary Items

- Computer for setting
- Utility for setting: TM-T20IV Utility
- USB cable

Follow the steps below to connect the printer.

- 1 Connect the printer to the computer via the USB cable.**
- 2 Turn on the computer.**
- 3 Turn on the printer.**
- 4 Start the TM-T20IV Utility.**
- 5 Select the printer, and then press the [OK] button.**
If the printer is not displayed, press the "Add Port" button, and then add the printer connected by USB.
- 6 Perform network I/F as well as TCP/IP settings.**
For details, see the TM-T20IV Utility User's Manual.
- 7 When you have finished making settings, disconnect the USB cable, turn off the printer, and then turn it back on.**

CAUTION

To start wireless LAN communication, be sure to disconnect the USB cable, turn off the printer, and then turn it back on.

Setting up from a Smart Device

Necessary Items

Prepare the following items.

- Device for setting: iOS or Android device
- Utility for setting: Epson TM Utility for iOS/Android

Running Epson TM Utility for iOS/Android

- 1** Run the Epson TM Utility for iOS/Android.



- 2** Set from “Wi-Fi Setup Wizard” in the menu.

Setup and Operation Workflow

1. Select the network you want to connect to.
2. Enter the passkey.
3. Perform a test print.

Connecting the Cash Drawer

CAUTION

- The optional external buzzer and the cash drawer cannot be used simultaneously. Do not connect both the optional external buzzer and the cash drawer to the printer at the same time by using a branched connector.
- The cash drawer cannot be used if the enable/disable setting for the optional external buzzer is set to "enable". When using the cash drawer, be sure to set it to "disable" using the Epson TM-T20IV Utility.
- Two driver transistors cannot be energized simultaneously.
- Leave intervals longer than 4 times the drawer driving pulse when sending it continuously.

Cash Drawer Requirements

Specifications of drawers differ depending on makers or models. When you use a drawer other than specified, make sure its specification meets the following conditions.

Otherwise, devices may be damaged.

- The load, such as a drawer kick solenoid, must be connected between pins 4 and 2 or pins 4 and 5 of the drawer kick connector.
- When the drawer open/close signal is used, a switch must be provided between drawer kick connector pins 3 and 6.
- The resistance of the load, such as a drawer kick solenoid, must be 24 ohms or more or the input current must be 1A or less.
- Be sure to use the 24V power output on drawer kick connector pin 4 for driving the equipment.

Drawer Connection Diagram

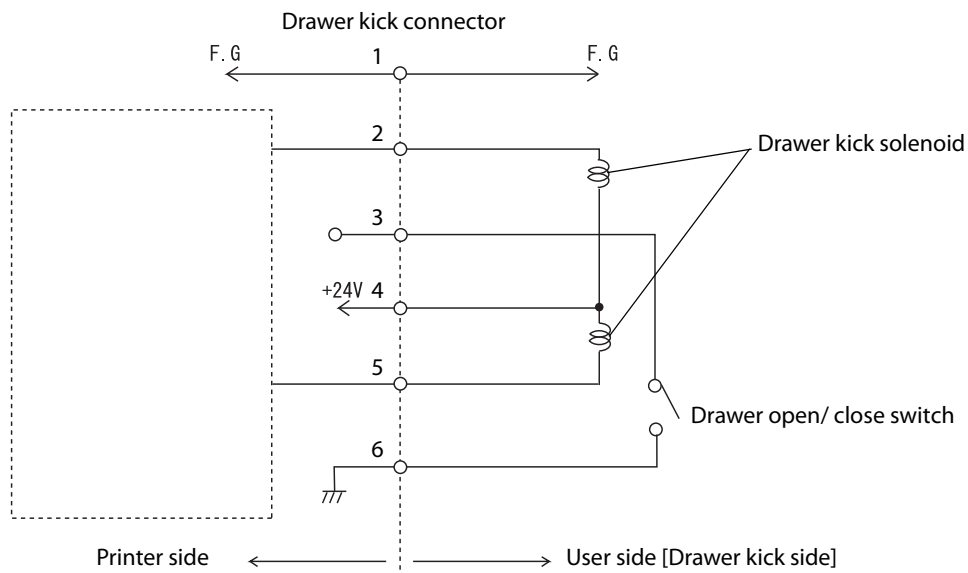

Adaptable Connector

Modular connector RJ12

Pin assignments

Pin number	Signal name	Direction
1	Frame GND	-
2	Drawer kick drive signal 1	Output
3	Drawer kick open/close signal	Input
4	+24 V	-
5	Drawer kick drive signal 2	Output
6	Signal GND	-

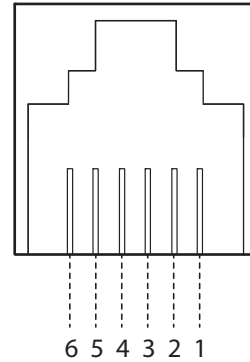

Connecting the Drawer Kick Cable



- To prevent malfunctions, use a drawer kick cable that ensures the frame ground is connected.
- The printer provides power for the cashdrawer via pin 4 of its connector. This pin should be used to power the cashdrawer.
- To prevent the possibility of damaging the printer and other devices, do not connect the DK connector to a wired telephone system.

Connect the drawer kick cable to the drawer kick connector by pressing firmly until the connector clicks into place.

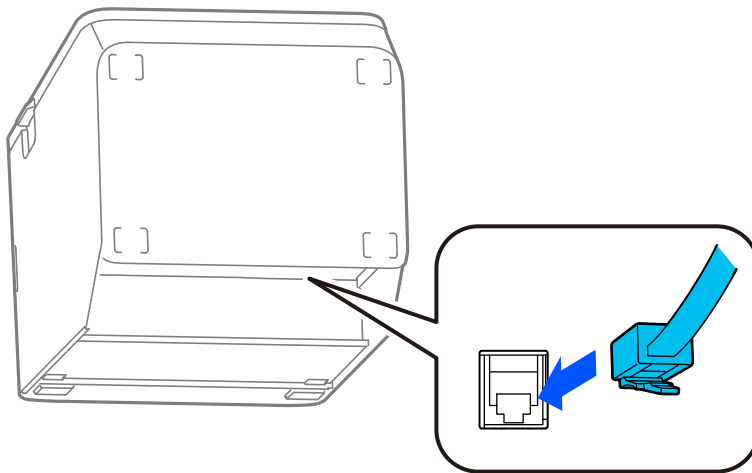

Connecting the Optional External Buzzer

When the optional external buzzer (model: OT-BZ20) is connected to the drawer kick connector of the printer, you can set the printer so that it beeps when you send commands, when an error occurs, when executed auto cutting, and when detected paper end. Settings for sound patterns and frequency depending on the occasions the buzzer beeps are also available.

Use the TM-T20IV Utility to make the buzzer settings: enable/disable setting, sound pattern setting, and frequency setting.

CAUTION

- Be sure to turn off the printer before you connect/disconnect the optional external buzzer.
- The optional external buzzer and the cash drawer cannot be used simultaneously. Do not attempt to connect both the optional external buzzer and the cash drawer to the printer at the same time by using a "Y" split cable or adapter.

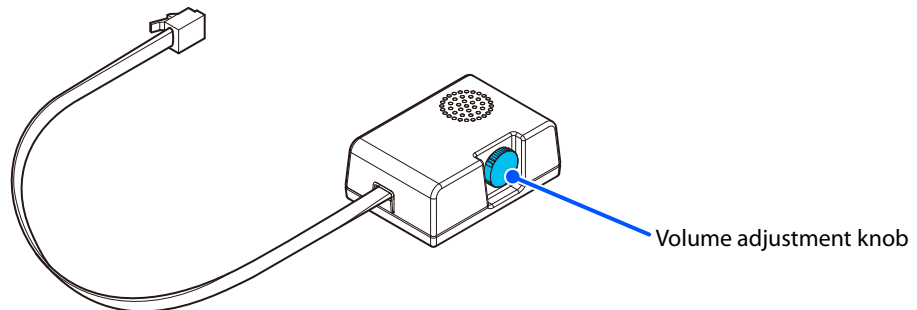

Connecting Procedure

The optional external buzzer is recommended to be installed in the following positions.

- When using the printer horizontally: either side
- When using the printer vertically or on a wall: either side/top/bottom (only for wall hanging installation)

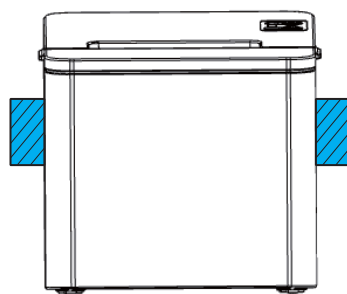

**Horizontal installation
(Front View)**

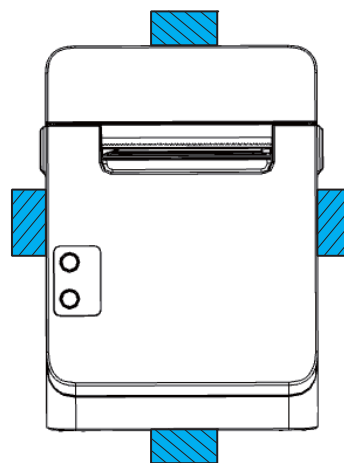

**Vertical/Wall-hanging installation
(Front View)**

CAUTION

- Do not place the optional external buzzer where the paper exits the printer.
- To prevent liquid from entering inside, it is recommended to install the optional external buzzer so that the volume adjustment knob is positioned sideways or downward.

- 1 Turn off the printer.
- 2 Clean and dry the printer case where the buzzer will be installed.
- 3 With 2 included pieces of the affixing tape combined, peel off the backing paper on one side, and stick the tape in the center of the attaching surface of the buzzer unit.

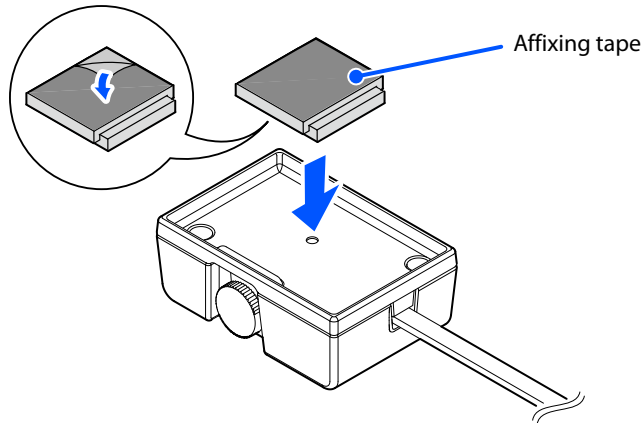

- 4 Connect the cable of the buzzer to the drawer kick connector on the printer.

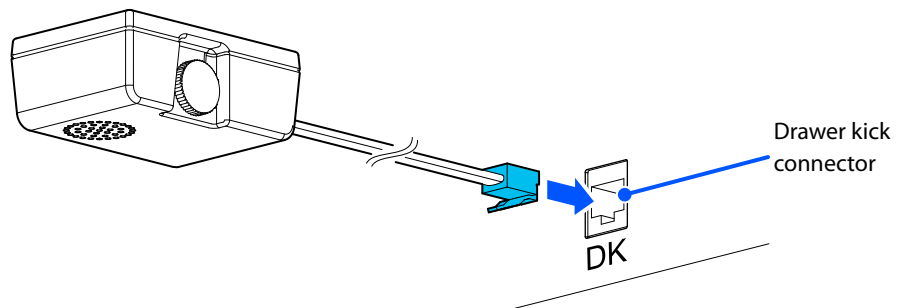

- 5 Peel off the backing paper on the other side of the affixing tape, and attach the buzzer unit to the printer case.

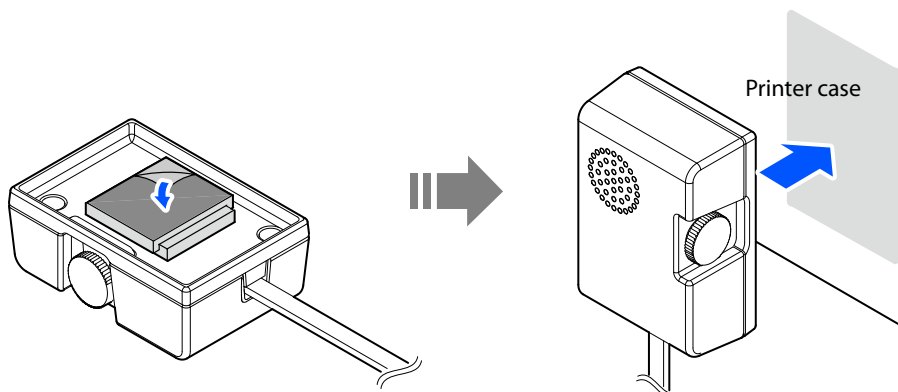

Connecting the Optional Wireless LAN Unit

For USB/Ethernet/Serial model users, the printer can be connected wirelessly by connecting the optional wireless LAN cable set (OT-WL06) to the printer.

For more information, refer to User's Manual of the Wireless LAN cable set.

CAUTION

- Be sure to turn off the printer when connecting the Wireless LAN unit.
- Depending on the installation conditions of the printer and the routing for cables connected to it, the status of the radio waves for the Wireless LAN unit may decline. If this does happen, use an extension cable.

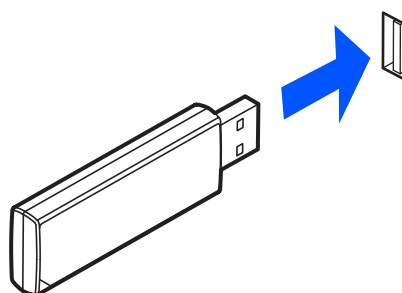

Changing the Paper Width

You can change the paper width from 80 to 58 mm {3.15 to 2.28 in.} by installing the included 58-mm {2.28 in.} width roll paper guide. Follow the steps below to change the paper width.

CAUTION

Because some parts of the print head and the autocutter contact the platen and they may become worn out, once you change the paper width from 80 to 58 mm {3.15 to 2.28 in.} and use the printer, you cannot change it back to 80 mm {3.15 in.}.

- 1** Open the roll paper cover.
- 2** Align the three tabs of the 58-mm {2.28 in.} width roll paper guide with the rectangular holes in the printer, and push the guide downward.

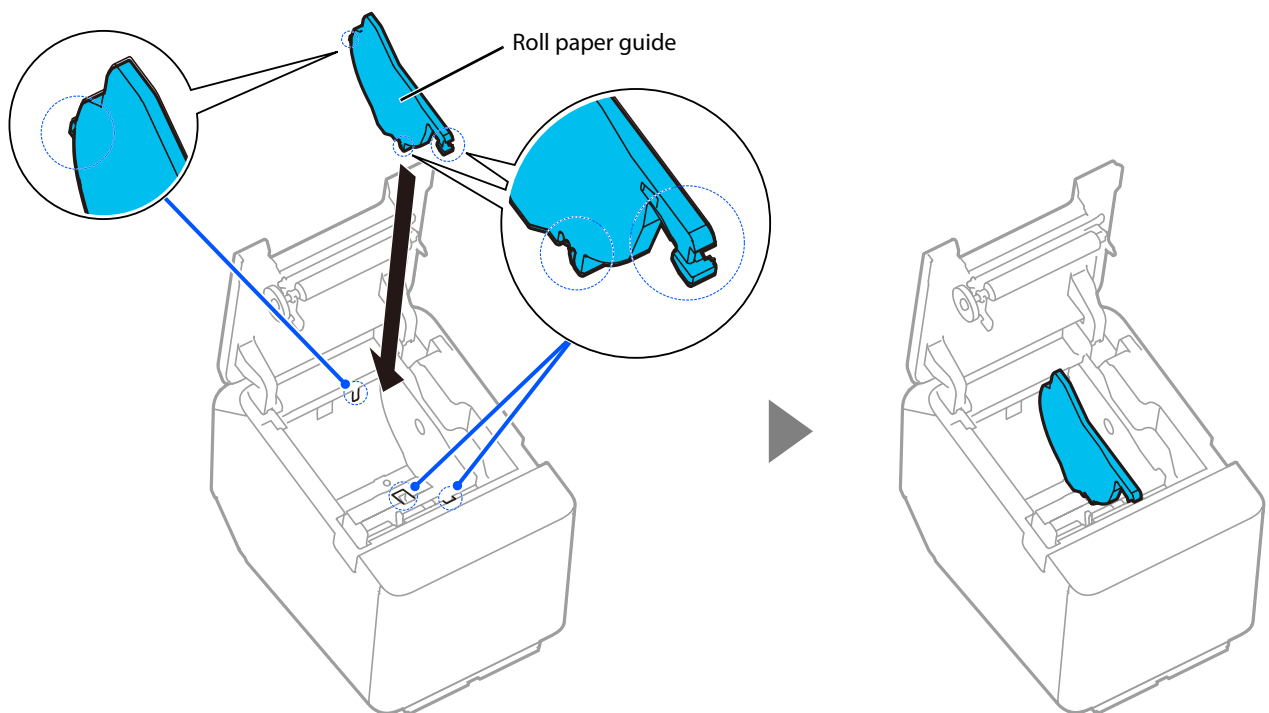

- 3** Set the paper width in software setting mode.
For more information, see ["Software Settings"](#) on page 45.

Advanced Usage

Software Settings

The printer offers memory switches and customized values which allow you to make various settings for the printer.

The settings can be made in any of the methods listed in the table below or by using the ESC/POS commands.

For an explanation of each function and setting, see ["Overview of Each Function" on page 46](#).

Item/Method	Software Setting Mode	Epson TM-T20IV Utility
Interface Settings		
Serial Baud Rate	✓	✓
Serial Parity	✓	✓
Serial Handshaking	✓	✓
Serial Data Bits	✓	✓
Serial Data Receive Error	✓	✓
USB Class	✓	✓
USB Power Saving	✓	✓
Receive Buffer Capacity	✓	✓
BUSY Condition	✓	✓
Auto Line Feed	✓	✓
Output Paper-end Signals	✓	
Error Signal	✓	✓
Interface Selection	✓	✓
Interface switch waiting time	✓	✓
Main connection interface	✓	✓
Print Density	✓	✓
Print Speed	✓	✓
Automatic Reduction of Paper	✓	✓
Auto Paper Feed&Cut at cover close	✓	✓
Character/Column Settings		
Code Page	✓	✓
International Character Set	✓	✓
Embedded Font Replacement	✓	
Thai Character Composition	✓	
Paper Width & Print Column	✓	✓
Buzzer Control	✓	✓
Near-end Detection	✓	✓
Power Supply Unit Capacity	✓	✓

NOTE

- For detailed information about the Epson TM-T20IV Utility, refer to the TM-T20IV Utility User's Manual.
- For information about how to use the memory switch setting mode, see ["Software Setting Mode" on page 55](#).

Overview of Each Function

Interface Settings

Serial Baud rate

- 2400 bps
- 4800 bps
- 9600 bps
- 19200 bps
- 38400 bps (Initial setting)
- 57600 bps
- 115200 bps

Serial Parity

- None (Initial setting)
- Odd
- Even

Serial Handshaking

- DTR/DSR (Initial setting)
- XON/XOFF

Serial Data Bit

- 7 bits
- 8 bits (Initial setting)

Serial Data Receive Error

- Print “?” (Initial setting)
- Ignored

USB Class

- Vendor Class
- Printer Class (Initial setting)

USB Power Saving

- Enabled
- Disabled (Initial setting)

NOTE

The USB power-saving function is valid only when the USB interface communication condition is set to the vendor-defined class and the system configuration is set so that the USB driver can support the USB power-saving function.

Receive Buffer Capacity

- 4 KB (Initial setting)
- 128 KB

BUSY Condition

- Receive Buffer Full or Offline (Initial setting)
- Receive Buffer Full

CAUTION

- In either case above, the printer enters the BUSY state after power is turned on, and when a self-test is being run.
- If BUSY condition is set to "Receive buffer full," the printer will not become BUSY
 - * When the roll paper cover is open
 - * When paper is fed by the FEED button
 - * When printing has stopped for a paper out
 - * When macro execution ready state
 - * When error has occurred

Auto Line Feed

- Always disabled (Initial setting)
- Always enabled

Output Paper-end Signals

- Paper End&Near-end Sensor Enabled (Initial setting)
- Disabled

Error Signal

- Enabled (Initial setting)
- Disabled

Interface Selection

- Com (Serial)
- Built-in USB
- Ethernet/Wi-Fi (USB/Ethernet/Serial model only)
- All interfaces enabled (Initial setting)

Interface switch waiting time

Select the number of seconds from 1 to 10 in increments of 1 second, or 60 seconds.

Initial setting

- USB/Serial model: 1 second
- USB/Ethernet/Serial model: 10 seconds

Main connection interface

- Com (Serial)
- Built-in USB
- Ethernet/Wi-Fi (USB/Ethernet/Serial model only)
- Auto (Initial setting)
- No main connection I/F

Print Density

Selectable from +3 to -3 (dark to light)

Initial setting: 0

Depending on the paper type, it is recommended to set the printer density for the best print quality.

NOTE

When the print density level is increased, print speed may be reduced.

Print Speed

Selectable from levels 1 to 13 (Slow ~ Fast)

Initial setting: Level 13

NOTE

Depending on print conditions, such as print duty, thermal head temperature, and data transmission speed, print speed is automatically adjusted, which may cause white lines due to intermittent print (the motor sometimes stops). To avoid this, keep the print speed constant by setting it lower.

Automatic Reduction of Paper

- No Reduction (Initial setting)
- Recommended setting
- Maximum Reduction

	Recommended setting	Maximum paper reduction
Top margin	Reduced	Reduced
Bottom margin	Reduced	Reduced
Line spacing	Reduced by 75%	Reduced by 75%
Line break	Reduced by 75%	Reduced by 75%
Barcode height	Reduced by 75%	Reduced by 75%
Space around each character	Not reduced	Reduced by 75%

NOTE

- Paper reduction is not performed for space dot lines of graphics printing data.
- When reducing barcode height, reading of the barcode is not guaranteed. Be sure to check that the barcode can be read with a user's barcode reader in advance.

Auto Paper Feed&Cut at cover close

- Enable (Initial setting)
- Disable

Character/Column Settings

NOTE

Refer to the following URL regarding the Code page and the International character set.
https://support.epson.net/publist/reference_en/

Code Page

Selectable from 43 pages including user-defined page

Initial setting: PC437: USA, Standard Europe

International Character Set

Selectable from 18 sets

Initial setting: USA

Embedded Font Replacement

- Font A Replacement
- Font B Replacement

Paper Width & Print Column

CAUTION

- To change the paper width, you need to install the 58 mm width paper guide plate. (See "Changing the Paper Width" on page 44.)
- Because some parts of the print head and the autocutter contact the platen and they may become worn out, once you change the paper width from 80 to 58 mm {3.15 to 2.28 in.} and use the printer, you cannot change it back to 80 mm {3.15 in.}.

- 80 mm {3.15 in.} width paper/48 characters (Initial setting)
- 80 mm {3.15 in.} width paper/42 characters
- 58 mm {2.28 in.} width paper/35 characters
- 58 mm {2.28 in.} width paper/42 characters

Buzzer Control

NOTE

- For information about how to connect the optional external buzzer, see "Connecting the Optional External Buzzer" on page 41.
- When the optional external buzzer is enabled, a cash drawer cannot be used. Be sure to disable it when you use a cash drawer.

Select Buzzer

- Buzzer Disable (Initial setting)
- Option Buzzer
- Internal Buzzer

Sound Pattern (Error)

- Default (Initial setting)
- Selectable from Patterns A to E

Buzzer Frequency (Error)

- Continuous (Initial setting)
- 1 time
- No sound

Sound Pattern (Auto Cut)

Selectable from Patterns A to E

Initial setting: Pattern A

Buzzer Frequency (Auto Cut)

- 1 time (Initial setting)
- No sound

Sound Pattern (Pulse 1)

Selectable from Patterns A to E

Initial setting: Pattern A

Buzzer Frequency (Pulse 1)

- 1 time (Initial setting)
- No sound

Sound Pattern (Pulse 2)

Selectable from Patterns A to E

Initial setting: Pattern B

Buzzer Frequency (Pulse 2)

- 1 time (Initial setting)
- No sound

Sound Pattern (Paper End)

- Default (Initial setting)
- Selectable from Patterns A to E

Buzzer Frequency (Paper End)

- Continuous (Initial setting)
- 1 time
- No sound

Sound Pattern (Power On)

Selectable from Patterns A to E

Initial setting: Pattern D

Buzzer Frequency (Power On)

- 1 time (Initial setting)
- No sound

Near-end Detection

- Disabled (Initial setting)
- Enabled

Power Supply Unit Capacity

- Level 1 (Low)
- Level 2
- Level 3 (High) (Initial setting)

Setting/Checking Modes

As well as print mode, the following modes are also provided for making various printer settings and checking items.

- Self-test mode
- NV graphics information print mode
- Receipt Enhancement information print mode
- Software setting mode (Customize Value Setting)
- Restore default values mode
- Interface setup mode (USB/Ethernet/Serial model only)
- Peripheral device information print mode
- Hexadecimal dumping mode

To enter the Self-test mode or the Hexadecimal dumping mode, turn the printer on with the special operations as described below.

To enter one of the other modes, first enter the Self-test mode, and then select one mode by operating the Feed button as described below.

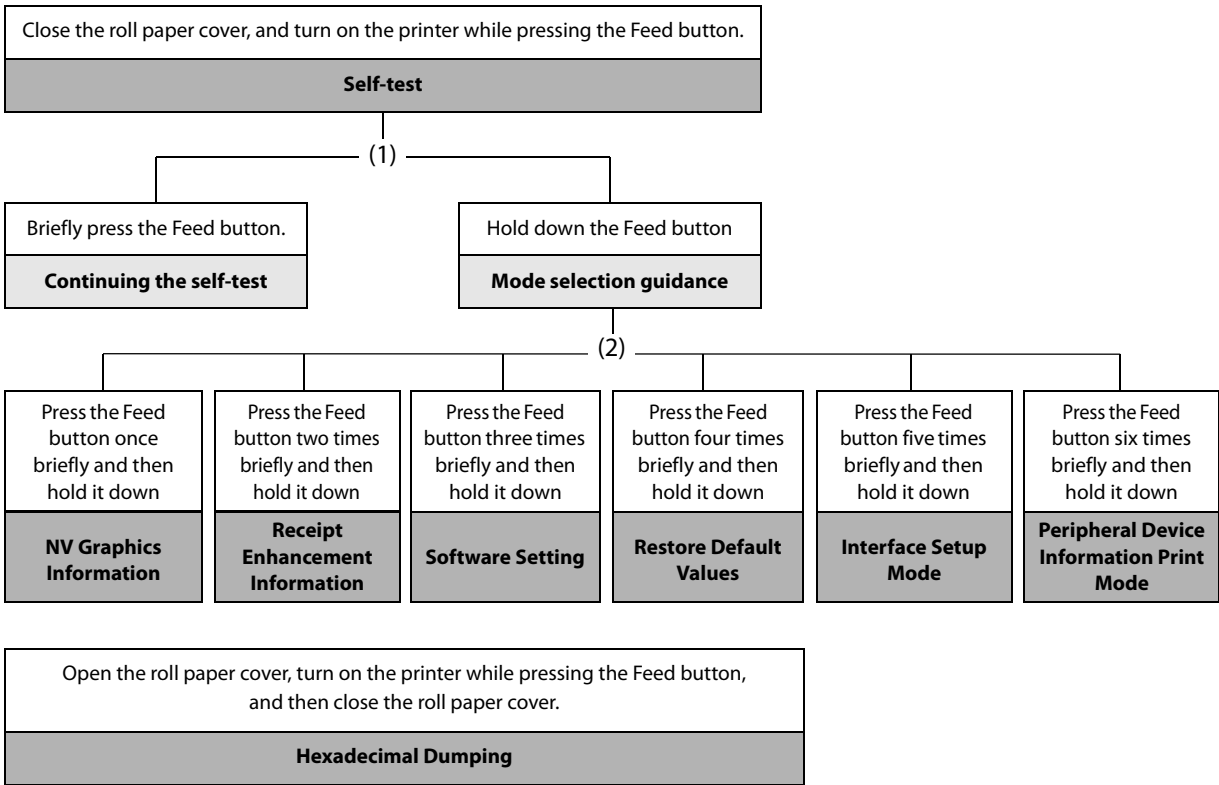

In (1) and (2), the following guidances are printed, the Paper LED flashes, and instructs the user's operations.

1. Continuing self-test guidance

Select Modes by pressing Feed Button.
Continue SELF-TEST: Less than 1 second
Mode Selection : 1 second or more

2. Mode selection guidance

Mode Selection

Modes

- 0: Exit and Reboot Printer
- 1: NV Graphics Information
- 2: Receipt Enhancement Information
- 3: Customize Value Settings
- 4: Restore Default Values
- 5: Interface Setup
- 6: Peripheral Device Information
- 7 or more: None

Select Modes by executing following procedure.

- step 1. Press the Feed button less than 1 second as many times as the selected mode number.
- step 2. Press Feed button for 1 second or more.

Self-test Mode

You can check the following items using the self-test.

- Product name
- Firmware version
- Product serial number
- Interface information
- Resident fonts
- Maintenance counter information (print head running length, number of times of auto-cutting)

Follow the steps below. The self-test can also be executed using ESC/POS Commands.

1 Close the roll paper cover.

2 While pressing the Feed button, turn on the printer. (Hold down the Feed button until printing starts.)

After printing the current print status, a Continuing self-test guidance is printed, and the Power LED flashes.

3 Briefly press the Feed button (less than one second) to continue the self-test.

The printer prints a rolling pattern on the roll paper, using the built-in character set.

After "*** completed ***" is printed, the printer initializes and switches to standard mode.

NV Graphics Information Print Mode

Prints the following NV graphics information registered to the printer.

- Capacity of the NV graphics
- Used capacity of the NV graphics
- Unused capacity of the NV graphics
- Number of NV graphics that are registered
- Key code, number of dots in X direction, number of dots in Y direction to be defined.
- NV graphics data

NOTE

For details on NV graphics, see ["NV Graphics Memory" on page 20](#).

Follow the steps below.

1 After running a self-test, hold down the Feed button for at least one second to enter the Mode selection.

The Mode selection guidance is printed, and the Paper LED flashes.

- 2** After briefly (less than one second) pressing the Feed button once, hold it down for at least one second, to print the NV graphics information.
After information printing, the Mode selection guidance is printed again.
- 3** To finish, turn off the power, or select "Exit and Reboot Printer".

Receipt Enhancement Information Print Mode

You can check the following items using the R/E information mode:

- Auto top logo printing setting
- Auto bottom logo printing setting
- Extended settings for auto top/bottom logo printing

Follow the steps below.

- 1** After running a self-test, hold down the Feed button for at least one second to enter the Mode selection.
The Mode selection guidance is printed, and the Paper LED flashes.
- 2** After briefly (less than one second) pressing the Feed button twice, hold it down for at least one second, to print the R/E information.
After information printing, the Mode selection guidance is printed again.
- 3** To finish, turn off the power, or select "Exit and Reboot Printer".

Software Setting Mode

You can change the printer settings. For information on available setting items, see "[Software Settings](#)" on page 45.

Follow the steps below.

- 1** After running a self-test, hold down the Feed button for at least one second to enter the Mode selection.
The Mode selection guidance is printed, and the Paper LED flashes.

2 Briefly press the Feed button three times (less than one second), hold it down for at least one second to enter the Software setting mode (Customized Value Settings).

The Software setting mode guidance is printed, and the Paper LED flashes.

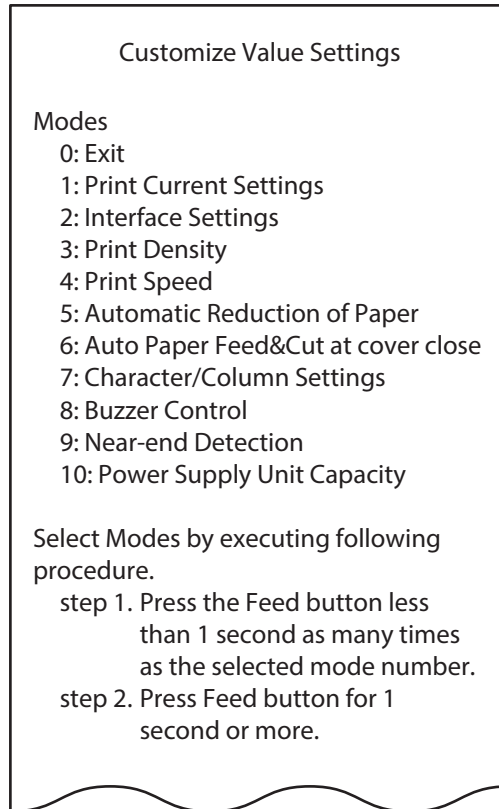

3 After briefly pressing the Feed button (less than one second) for the number of times shown in the print result, hold down the button for more than one second to select the setting items.

The setting selected as the setting item, the current settings and default settings are printed. Depending on the setting item, you may need to continue selecting the setting item before the settings are printed.

For details on setting items, see ["Software Settings" on page 45](#).

CAUTION

When set to a value other than those in the software setting mode, the current settings are not printed.

4 Select a setting by briefly pressing the Feed button (less than one second) for the number of times applicable to the setting, and then hold down the button for more than one second to confirm your selection.

After saving the settings, the Software setting mode guidance is printed, and the Paper LED flashes.

5 To close Software setting mode, turn off the printer, or select "Exit" to return to Mode selection guidance, and then select "Exit and Reboot Printer".

NOTE

- To select 0 as the item number, hold down the Feed button until printing starts.
- If the button is pressed a number of times that is not displayed by the Setup guidance, the operation is invalid and the same guidance is printed.

Restore Default Values Mode

In Restore default values mode, following values saved on NV Memory will be set back to default settings. When any error occurs, you can use to specify the reason.

Setting Contents	Setting Items	Restore Default Values and Delete Defined Data
Customized value	✓	✓
Memory Switches	✓	✓
R/E (Receipt Enhancement) settings	✓	✓
Communication condition of USB interface	✓	✓
Communication condition of serial interface	✓	✓
Communication condition of network interface	✓	✓
NV graphics	-	✓
NV bit image	-	✓
User-defined page	-	✓
User NV Memory	-	✓

Follow the steps below.

1 After running a self-test, hold down the Feed button for at least one second to enter the Mode selection.

The Mode selection guidance is printed, and the Paper LED flashes.

2 Briefly press the Feed button four times (less than one second), hold it down for at least one second to enter the Restore Default Values.

The guidance is printed.

**3 When only restoring the default settings:
Briefly press the Feed button once (less than one second), hold it down for at least one second. (Hold down the Feed button until the restoration complete message is printed.)**

**When restoring default settings and deleting user defined data:
Briefly press the Feed button twice (less than one second), and then hold it down for at least one second. (Hold down the Feed button until the restoration complete message is printed.)**

4 To finish, turn off the power.

NOTE

If you could not confirm that settings were restored to the default values, execute [Restore Default Values Mode] again. If the firmware version is 30.08 ESC/POS or later, the following message is printed when the restoration fails.

```
Failed restoration to Factory Default.  
Please retry after restarting printer.
```

Interface Setup Mode

Use this mode to setup the interface and other settings.

Follow the steps below.

- 1 After running a self-test, hold down the Feed button for at least one second to enter the Mode selection.**

The Mode selection guidance is printed, and the Paper LED flashes.
- 2 Briefly press the Feed button five times (less than one second), hold it down for at least one second to enter the Interface Setup mode.**

The guidance is printed.
- 3 After briefly pressing the Feed button (less than one second) for the number of times shown in the print result, hold down the button for more than one second to select the setting items.**

Initialize

Select [Wi-Fi & Ethernet Setup] and select [Initialize] to initialize the network setting parameter. The printer is reset and restarted.

NOTE

If you could not confirm that the interface settings were initialized, execute [Initialize] again. If the firmware version is 30.08 ESC/POS or later, the following message is printed when the initialization fails.

Failed restoration to Factory Default.
Please retry after restarting printer.

SimpleAP mode (OT-WL06)

Select [Wi-Fi & Ethernet Setup] and select [SimpleAP] to start in SimpleAP mode (the same as the factory default setting). The printer is reset and restarted, and it begins printing the “SimpleAP Start” information.

Select this option when setting up a Wi-Fi connection.

NOTE

For information on the Quick connection function, see ["Simple Setup for Wireless LAN \(when OT-WL06 is used\)"](#) on page 22.

Peripheral Device Information Print Mode

This function allows you to print information for the device (Wi-Fi adapter information) currently connected to the printer.

Follow the steps below.

- 1 After running a self-test, hold down the Feed button for at least one second to enter the Mode selection.**
The Mode selection guidance is printed, and the Paper LED flashes.
- 2 Briefly press the Feed button six times (less than one second), hold it down for at least one second to print the Peripheral Device Information.**
After information printing, the Mode selection guidance is printed again.
- 3 To finish, turn off the power, or select “Exit and Reboot Printer”.**

Hexadecimal Dumping Mode

In the hexadecimal dumping mode, the printer prints the data transmitted from a host computer in hexadecimal numbers and their corresponding characters. It enables you to check if data is transmitted to the printer correctly.

NOTE

- If there is no character corresponding to print data, "" is printed.
- If you press the Feed button when there is less than one line of print data, one line is printed.
- During hexadecimal dumping mode, applications that check the printer status may not operate correctly. The printer only returns the status for the "Real-time transmission status" command.

Follow the steps below. Hexadecimal Dumping Mode can also be executed using ESC/POS Commands.

- 1 Open the roll paper cover.**
- 2 While pressing the Feed button, turn on the printer. (Hold down the Feed button until the Error LED turns on.)**
- 3 Close the roll paper cover.**
The printer starts printing data received from then on in hexadecimal numbers and their corresponding ASCII characters.

Example of printing in hexadecimal dumping mode:

```
Hexadecimal Dump
To terminate hexadecimal dump,
press FEED button three times.

1B 21 00 1B 26 02 40 40 1B 69 . ! . . & . @ @ . i
1B 25 01 1B 63 34 00 1B 30 31 . % . . c 4 . . 0 1
41 42 43 44 45 46 47 48 49 4A A B C D E F G H I J

*** completed ***
```

- 4 To close hexadecimal dumping mode, turn off the printer after printing is complete, or press the Feed button for three times.**

Printing a Status Sheet

Follow the steps below to check the interface settings.

CAUTION

- Ethernet and Wi-Fi status sheets are not printed while the printing communication protocol is being established. They will be printed after the connection is cut off (including being cut due to a time out).
- "(none)" is printed for the "Connected Peripheral" if no peripherals are connected to the USB-A connector.

Using the Status Sheet Button

- 1 Check that the printer is turned on.**
Make sure the roll paper cover is closed.
- 2 If there is the connector cover, remove the cover.**
- 3 Hold down the status sheet button for at least three seconds.**
A guidance that starts with "Next Action" will be printed.
- 4 Press the Feed button briefly (less than one second) the number of times equal to the number indicated to the left of the status sheet you want to print, then hold down the button for at least one second.**
Printing of a status sheet will start. The printer will return to normal mode after printing is finished.

Using the Feed button

- 1 Check that the printer is on.**
- 2 Open the roll paper cover.**
- 3 Hold down the Feed button for at least one second.**
- 4 Close the roll paper cover.**
A guidance that starts with "Next Action" will be printed.

5 Press the Feed button briefly (less than one second) the number of times equal to the number indicated to the left of the status sheet you want to print, then hold down the button for at least one second.

Printing of a status sheet will start. The printer will return to normal mode after printing is finished.

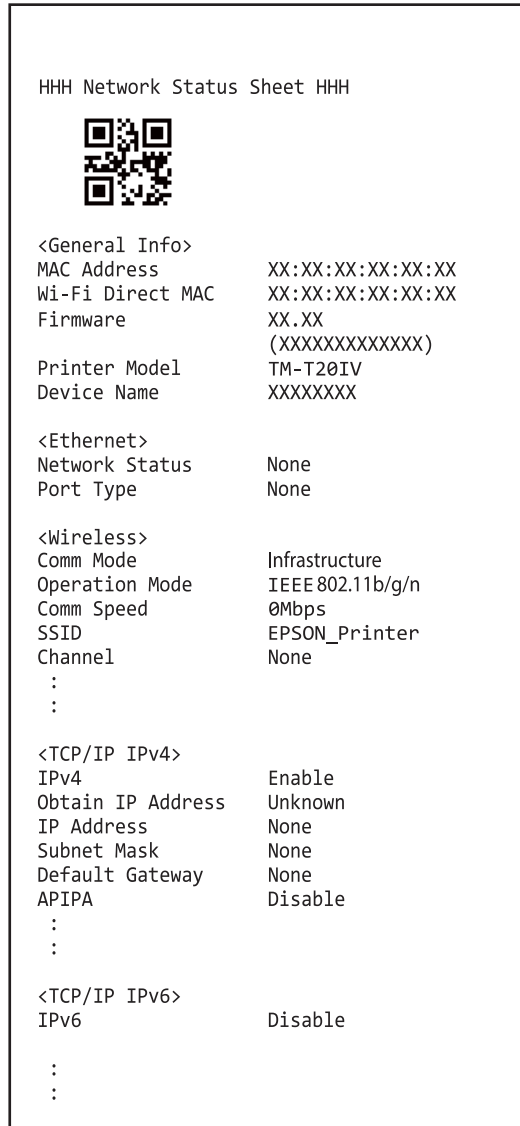

Resetting the Interface Settings

Follow the steps below to reset the interface settings.

NOTE

- You can return the interface settings to their defaults from the Interface Setup mode. For details on the Interface Setup mode, see "[Interface Setup Mode](#)" on page 59.
- Only network settings are returned to their defaults.

- 1 Turn off the printer and close the roll paper cover.**
- 2 Hold down the status sheet button while turning on the printer.**
A message is printed indicating that resetting is being performed, and the printer restarts.

CAUTION

Hold down the status sheet button until the initialization execution message is printed.

NOTE

If you could not confirm that the interface settings were initialized, execute [Initialize] again. If the firmware version is 30.08 ESC/POS or later, the following message is printed when the initialization fails.

Failed restoration to Factory Default.
Please retry after restarting printer.

Web Config

Web Config is a printer's built-in web page that allows you to check and change printer settings on your browser.

To use Web Config, you need to set your computer's IP address to the same segment as the printer.

How to Start Web Config

- 1 Start your web browser on a computer or smart device on the network and enter the IP address of the printer in the address field.

Example for HTTPS	Example for HTTP
IPv4: https://192.0.2.111/ IPv6: https://[2001:db8::1000:1]/	IPv4: http://192.0.2.111/ IPv6: http://[2001:db8::1000:1]/

- 2 After Web Config starts, select the menu you wish to configure.

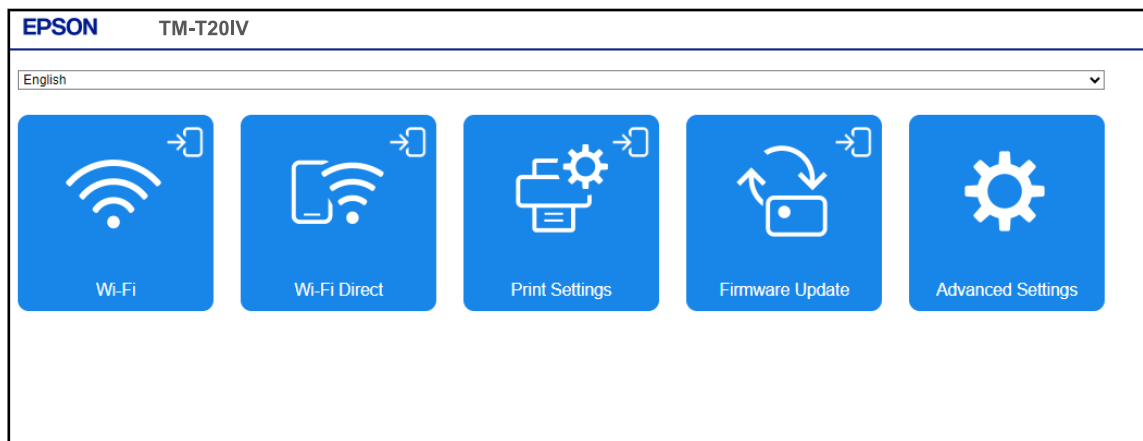

- 3 When the authentication screen appears, enter your password and log in.
For information about the default password, see ["Default administrator password for setting" on page 106](#).

NOTE

Enable JavaScript in your browser. Because a self-signed certificate owned by the printer is used when accessing HTTPS, a warning will appear in the browser when Web Config is started.

What can be Configured in Web Config

For information on what can be configured in Web Config, refer to the Web Config Reference Guide. The Web Config Reference Guide can be obtained from the URL listed in ["Download" on page 71](#).

Application Development Information

This chapter describes how to control the printer and gives information useful for printer application development.

Controlling the Printer

The printer supports the following command systems:

- ePOS-Print XML (Ethernet interface model only)
- ESC/POS

Users can control the printer by using the aforementioned command, or the following development kits or drivers.

- EPSON Advanced Printer Driver (APD)
- OPOS ADK
- OPOS ADK for .NET
- Epson ePOS SDK

ePOS-Print XML

ePOS-Print XML is the Epson original control command system for POS printers defined in XML. With ePOS-Print XML commands, you can print in environments where http communication is available and from OS applications. For detailed information about ePOS-Print XML, see the ePOS-Print XML User's Manual.

ESC/POS

ESC/POS is the Epson original printer command system for POS printers and customer display.

With ESC/POS commands, you can directly control all the printer functions, but detailed knowledge of printer specifications or combination of commands is required, compared to using drivers and applications.

For detailed information about ESC/POS commands, see the ESC/POS Command Reference for TM Printers that can be accessed from the following URL:

https://support.epson.net/publist/reference_en/

Controlling the Cash Drawer

A pulse output is sent to drawer kick connector pin 2 or pin 5, and you can open the drawer.

You can also check the open/close status of the drawer by checking the signal level of the drawer kick connector pin 3.

These controls are executed by a driver or by commands.

ESC/POS Commands

Prepare the output command for the specified pulse and the status transmission command.

For details, see the ESC/POS Command Reference.

For Windows Printer Drivers (APD)

You can set so that the drawer opens at the start of printing. For details, see the manual for drivers.

For details on control, see the manual for Status API of the driver.

OPOS (OCX Driver)

Register a cash drawer using the SetupPOS Utility, and control using the OpenDrawer method or the DirectIO function.

For details, see the “EPSON OPOS ADK MANUAL APPLICATION DEVELOPMENT GUIDE Cash Drawer” and the “UnifiedPOS Specification”.

OPOS for .NET

Register a cash drawer using the SetupPOS Utility, and control using the OpenDrawer method or the DirectIO function.

For details, see the “EPSON OPOS ADK for .NET MANUAL Application Development Guide Cash Drawer (EPSON Standard)” and the “UnifiedPOS Specification”.

Epson ePOS SDK

The output command for the drawer kick pulse and the status transmission command are provided in each SDK library. For details, see the user's manuals provided with each SDK.

NOTE

- Whether or not pin 2 or pin 5 operates the drawer kick connector depends on the connected cash drawer.
- You can acquire documents regarding the UnifiedPOS from the following link.
<https://www.omg.org/spec/UPOS>

Controlling the Optional External Buzzer

You can set the optional external buzzer to buzz when an error occurs and when an automatic cut off occurs.

The buzzer can be buzzed at any time using a driver or a command.

You can also set the timing and the beep pattern for the buzzer.

ESC/POS Commands

Use the buzzer control command or the output command for the specified pulse.

For details, see the ESC/POS Command Reference.

For Windows Printer Drivers (APD)

Use the DirectIO function or the API for opening the drawer. For details, see the manual for Status API of the drivers.

OPOS (OCX Driver)

Register a POS printer using the SetupPOS Utility and control using the DirectIO function.

For details, see the “EPSON OPOS ADK MANUAL APPLICATION DEVELOPMENT GUIDE POSPrinter (TM Series)”.

OPOS for .NET

Register a POS printer using the SetupPOS Utility and control using the DirectIO function.

For details, see the “EPSON OPOS ADK for .NET MANUAL Application Development Guide POS Printer”.

Epson ePOS SDK

The command for the buzzer function is provided in each SDK library. For details, see the user's manuals provided with each SDK.

NOTE

For details on setting the optional external buzzer, see "[Connecting the Optional External Buzzer](#)" on page 41.

Software

The following software is provided for application development.

Development Kits

Software	Description
EPSON OPOS ADK	This OCX driver can control POS peripherals using OLE technology.* Because controlling POS peripherals with original commands is not required on the application side, efficient system development is possible.
EPSON OPOS ADK for .NET	The OPOS ADK for .NET is a POS industry standard printer driver compatible with Microsoft POS for .NET. It allows you to develop applications that are compatible with the UPOS (Unified POS) specification. When developing applications, use a separate development environment such as Microsoft Visual Studio .NET.
EPSON JavaPOS ADK (Windows/Linux)	JavaPOS is the standard specification which defines an architecture and device interface (API) to access various POS devices from a Java based system. Using JavaPOS standard API allows control with Java based applications of functions inherent to each device. A flexible design with Java language and JavaPOS enables many different types of computer systems, such as stand alone or network configuration, to use a same application. You can use JavaPOS to build applications and drivers independently of platforms. This allows flexible configurations using thin clients to meet the system requirements.
Epson ePOS SDK	This is a development kit for controlling TM printers from native applications of smart devices or web applications. This includes libraries, manuals, and sample programs.
for Android	
for iOS	
for JavaScript	

* OLE technology developed by Microsoft divides software into part blocks. The OPOS driver is presupposed to be used with a development environment, such as Visual Basic, unlike ordinary Windows printer drivers. It is not a driver to be used for printing from commercial applications.

You can acquire documents regarding the UnifiedPOS from the following link.

<https://www.omg.org/spec/UPOS>

Drivers

Software	Description	Operating environment
EPSON Advanced Printer Driver (APD)	In addition to ordinary Windows printer driver functions, this driver has controls specific to POS. The Status API (Epson original DLL) that monitors printer status and sends ESC/POS commands is also attached to this driver.	Windows
EPSON TM Virtual Port Driver	This is a serial/parallel-USB/LAN conversion driver to make an Epson TM/BA/EU printer connected via USB or LAN accessible from a POS application through a virtual serial or parallel port. It allows you to directly control devices connected via USB or LAN with ESC/POS commands without making changes in the POS application that controls devices connected via a serial or parallel interface.	Windows
TM Series Printer Driver for Mac	This driver allows you to control the printer using Common UNIX Printing System (CUPS) on macOS. This is a full raster printer driver. It is able to print images, text, and vector graphics etc., that an application displays. With this driver many printer controls are possible, such as paper cut timing control, cash drawer control, printing speed control, blank line skip, and upside-down printing. It also provides API and dialogues for print setting, sample applications, and logo setting utility.	macOS
TM Series Printer Driver for Linux	This driver allows you to control the printer using Common UNIX Printing System (CUPS) on GNU/Linux. This is a full raster printer driver. It is able to print images, text, and vector graphics etc., that an application displays.	GNU/Linux

Utilities

Software	Description	Operating environment
TM-T20IV Utility	A utility for checking and changing various printer settings. Use this utility to: <ul style="list-style-type: none"> • Check the current settings • Test operation • Store logos • Set paper reduction • Set printing control • Set communication interfaces • Set the network • Save/restore settings 	Windows
Epson TM Utility	A utility that is available on the App Store or Google Play. Use this to perform wireless connection setup and change settings on the printer from iOS and Android devices. This utility also comes with some sample printing functions.	iOS, Android
Epson Deployment Tool	Use to make network and printer settings simultaneously. Allows you to make settings efficiently at the time of introducing TM printers for the first time, or when configuring multiple TM printers at the same time.	Windows
Epson Monitoring Tool	Use to check a list of status for the Epson printers connected to the network. You can also update certificates for multiple printers in a batch.	Windows

Others

Software	Description
ePOS-Print XML User's Manual	Describes ePOS-Print XML statements. This manual comes with sample programs.
Web Config Reference Guide	Describes items that can be configured in Web Config.

Download

You can obtain software and manuals from one of the following URLs.

For customers in North America, go to the following web site and follow the on-screen instructions.

<https://www.epson.com/support/>

For customers in other countries and regions, go to the following web site:

<https://epson.sn>

Precautions when Developing Applications

This section describes information that you should be aware of when developing systems and applications using this product.

Power Button Settings

This function allows you to disable turning the printer on and off with the power button. See ["Software Settings" on page 45](#) for setting instructions.

Settings

- **Manual:** The power button can be used to turn the printer on or off.
If you turn off your circuit breaker, the printer will be back on when the breaker is turned on.
- **Auto:** The power button is disabled.
If you turn off your circuit breaker, the printer will be back on when the breaker is turned on in the same way as when the setting is "Manual".

How to Turn Off the Printer when the Setting is Auto

There are the following methods to turn off the printer when the power button setting is set to "Auto".

- Turn off the power at the circuit breaker
- Disconnect the DC cable from the printer
- Disconnect the power plug from the wall outlet.

NOTE

If you want to turn off the printer without using the power button, it is recommended that you send the command to execute the power-off process to the printer before turning it off. This will save the latest maintenance counter values. The maintenance counter values are usually saved every two minutes. For more information about the command, see the ESC/POS Command Reference.

Notes on Printing Barcodes and Two-dimensional Symbols

- The user must set the quiet zone, depending on the barcode standards.
- When printing PDF417 (two-dimensional symbols), the following are recommended:
 - Module height: 3 to 5 times the module width
 - Vertical size of the symbol: approximately 5 mm {0.20 in.} or more
- The recognition rate of ladder barcodes and two-dimensional symbols may vary depending on widths of the modules, print density, environmental temperature, type of paper, and characteristics of the reader. Therefore, the user must check the recognition rate before setting the use conditions so that the restrictions of the reader are satisfied.
- Reading quality of barcodes and two-dimensional symbols in graphics multiple tone printing is not guaranteed.

- When printing ladder barcodes or two-dimensional symbols with graphics printing, use one of the following settings.

- Select the appropriate print control mode. (Recommended)

- Set the print speed to Level 6.

The print control mode and the print speed can be selected using the ESC/POS command.

Automatic Certificate Update Feature

This function automates registration and periodic updating of the security certificates registered to the printer. This reduces the burden on the user of tasks such as updating.

NOTE

This function is only available with the USB/Ethernet/Serial models.

Overview

When printing from application software that uses Epson ePOS SDK for JavaScript, if using security communication (SSL/TLS communication), security certificates must be registered on the printer and updated periodically.

Using this function automates the registration and periodic updates of security certificates so that users do not have to perform this task.

Use of this function requires the serial number of the connected printer to be entered.

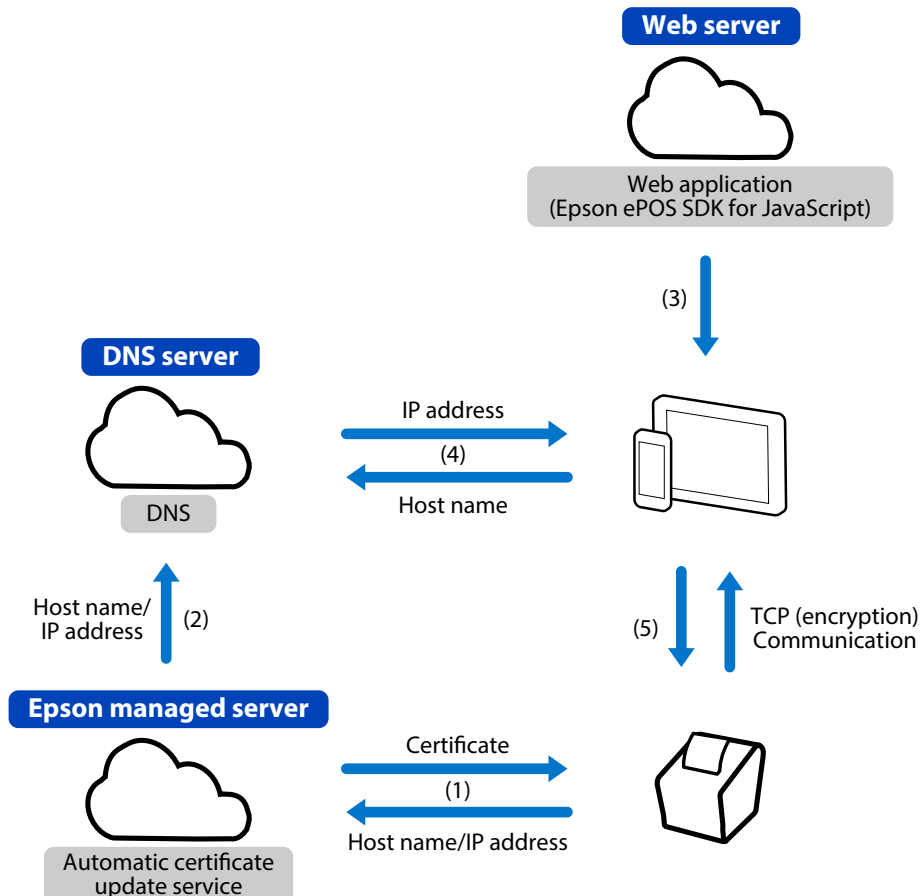

- (1) The printer downloads a certificate from the Epson-managed server and sends the host name and IP address.
- (2) The Epson server sets the host name and IP address to the DNS.
- (3) The host device uses a browser and web application to print.
- (4) The host device acquires the IP address associated with the host name from the DNS.
- (5) The host device uses TCP (encryption) communications with the printer to print.

NOTE

No personal information is acquired from the customer on the Epson-managed server side.

Use environment

- Application software developed using Epson ePOS SDK for JavaScript Ver.2.27.0b or later
- Both the host device and printer are connected to an Internet environment

Software required

- Epson ePOS SDK for JavaScript Ver.2.27.0b or later

One of the following setting utilities.

- TM-T20IV Utility
- Epson TM Utility
- Web Config

Refer to "[Software](#)" on page 69 for information on software.

Refer to "[Web Config](#)" on page 65 for Web Config details.

Limitations

- The security certificate is updated at printer startup and at a set time (if the printer has an update time set). If the printer is to run continuously without being turned off, be sure to set the update time.
- The printer will restart when the security certificate is updated. Since the printer cannot be used during the restart, set the update time to a time when the printer is not in use.
- Use NTP, etc., to set the printer time. This function may not operate correctly if the printer time is very incorrect.
- Depending on the proxy configuration, this function may not be usable. In this case, add the following to the browser's proxy exclusion list.
 - *.omnilinkcert.epson.biz
- If a security certificate is already registered, overwrite it.
- This function requires ISRG Root X1 in the host device certificate store.
- When saving the settings of the printer using TM-T20IV Utility or Epson TM Utility, save the security certificate as well. Otherwise, the settings may not be restored correctly.

Implementation

Programming in Epson ePOS SDK for JavaScript

For information on how to program in Epson ePOS SDK for JavaScript, refer to the user manual and samples included in Epson ePOS SDK for JavaScript.

Printer settings

- 1 **Use TM-T20IV Utility, Epson TM Utility, or Web Config to configure the following settings.**
 - Automatic Update of CA-signed certificates: Enable the setting
 - Update time: Set the time to update the certificate
 - Time Configuration: Set correct time (TimeServer)
 - Proxy: Set up proxy as needed
- 2 **Connect the host device and printer to an Internet environment.**
- 3 **Print from application software developed using Epson ePOS SDK for JavaScript.**
 To use this function, the host name of the printer must be designated when executing a connect method. The host name is generated by converting the serial number of the printer. A program to enter the printer's serial number is necessary on the application side. Refer to the sample programs in Epson ePOS SDK for JavaScript for information on how to convert to the host name.

Operation Check

Print the status sheet to check the status of the automatic update of CA-signed certificates.

```
Auto Cert Update : Enable
Server Access    : OK
```

Auto Cert Update / Automatic update of CA-signed certificates setting

- Disable: Certificates are not automatically updated
- Enable: Certificates are automatically updated

Server Access / Result of the last communication with the server for automatic certificate update

- OK: Successfully communicated
- Unknown: Was not communicating or is in communication
- NG (Failure): Communication failed

If "NG (Failure)" is printed, check the following.

- Is the printer connected to the Internet?
- Is the time setting of the printer correct?

Handling

This chapter describes basic handling of the printer.

Installing and Replacing Roll Paper



- Do not open the roll paper cover during printing. The printer may be damaged.
- Do not touch the manual cutter with your hands when installing or replacing the roll paper. Otherwise, you may be injured because the manual cutter blade is sharp.

CAUTION

- Use roll paper that meets the printer specification. For details about paper specification, see ["Paper Specifications" on page 89](#).
- Do not use a roll paper whose end is pasted to the paper core.

1 Open the roll paper cover.

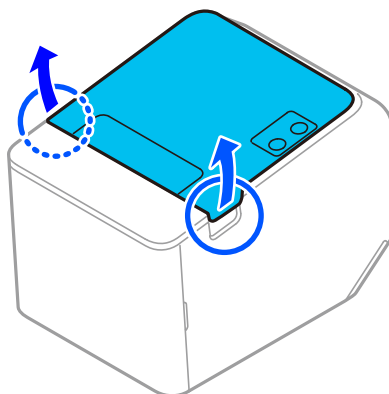

2 Remove the used roll paper core, if any.

3 Install the roll paper in the correct direction.

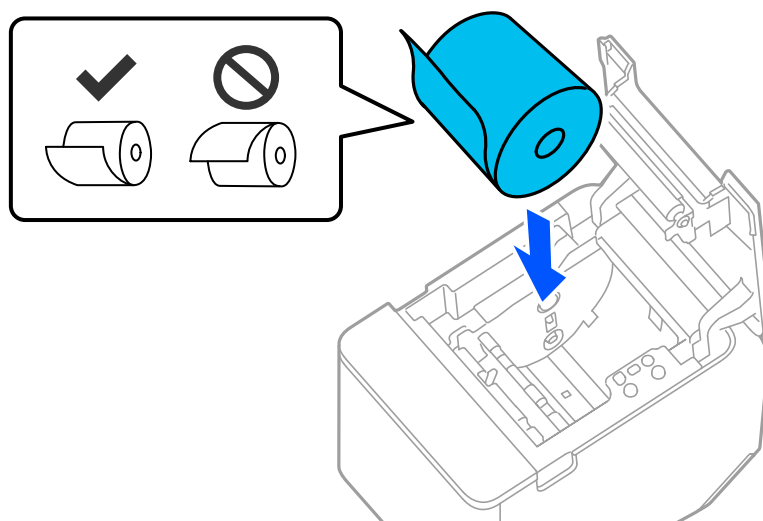

- 4** Pull out some roll paper, and close the roll paper cover.

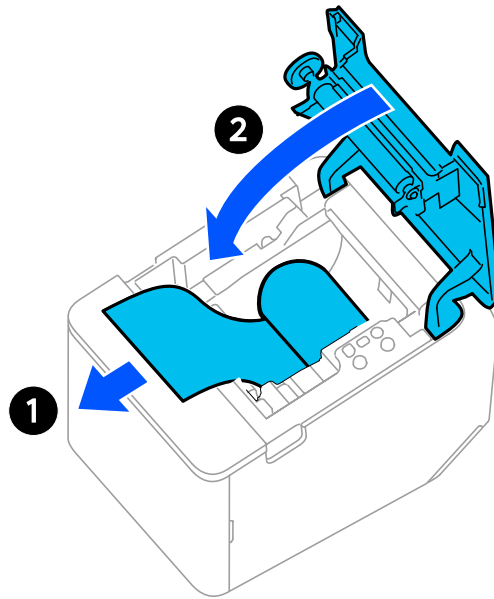

Removing Jammed Paper

When a paper jam occurs, never pull out the paper forcibly. Open the roll paper cover, and then remove the jammed paper.



Do not touch the thermal head. (See "[Cleaning the Thermal Head/Platen Roller](#)" on page 81.) After printing, the thermal head and its surroundings can be very hot.

When the Roll Paper Cover Cannot be Opened

If a foreign substance has entered the autocutter or the roll paper jams, the autocutter blade cannot return to the correct position and it locks in place. In this situation, the roll paper cover does not open even if you pull the cover open lever.

Follow the steps below to return the autocutter blade to its normal position.

- 1 Turn off the printer.**
- 2 Slide the cutter cover toward the front to open it.**

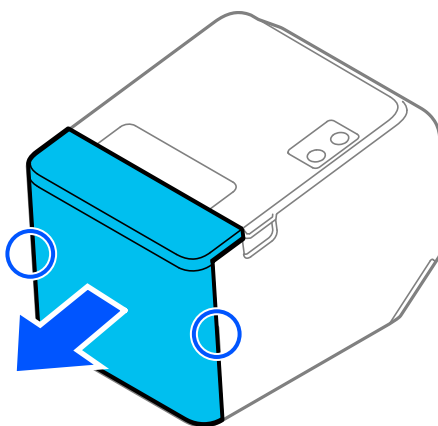

- 3 Turn the knob until you see a triangle in the opening. This returns the cutter blade to the normal position.**

Refer to the operation instructions engraved on the back of the cutter cover.

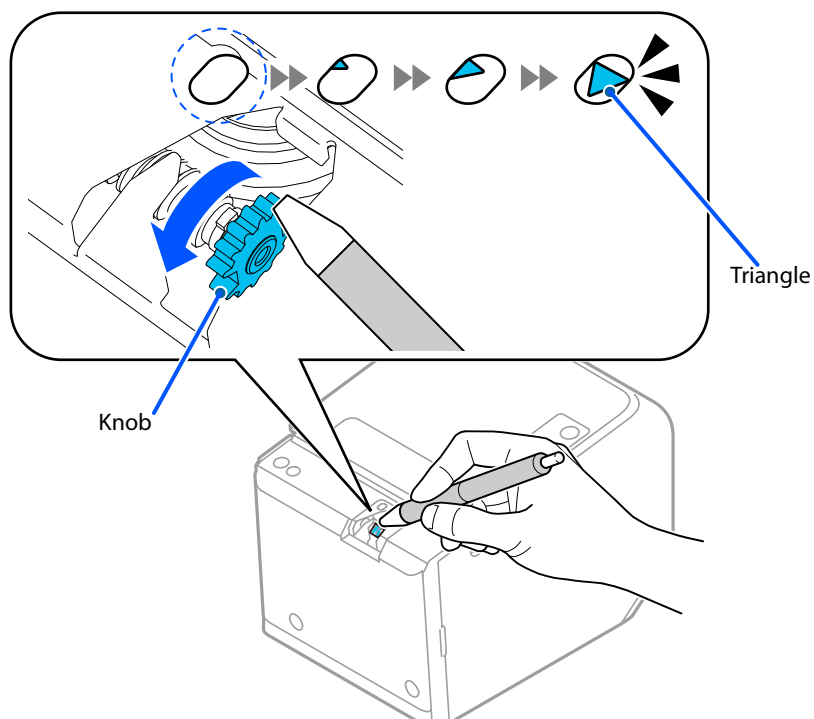

- 4 Close the cutter cover.**
- 5 Open the roll paper cover and remove the jammed paper.**

Cleaning the Printer

Cleaning the Printer Case

Be sure to turn off the printer, and wipe the dirt off the printer case with a dry cloth or a damp cloth. Be sure to unplug the AC cable while cleaning.



Never clean the product with alcohol, benzine, thinner, or other such solvents. Doing so may damage or break the parts made of plastic and rubber.

Cleaning the Thermal Head/Platen Roller

Epson recommends cleaning the thermal head periodically (generally every 3 months) to maintain receipt print quality. Depending on the roll paper used, paper dust may stick to the platen roller and cause an irregular paper feed. To remove the paper dust, clean the platen roller with a cotton swab moistened with water. Turn on the printer power only after the water has completely dried.

Turn off the printer and open the roll paper cover. Clean the thermal elements of the thermal head with a cotton swab moistened with an alcohol solvent (ethanol or IPA).



- After printing, the thermal head can be very hot. Do not touch it and let it cool before you clean it.
- Do not damage the thermal head by touching it with your fingers or any hard object.

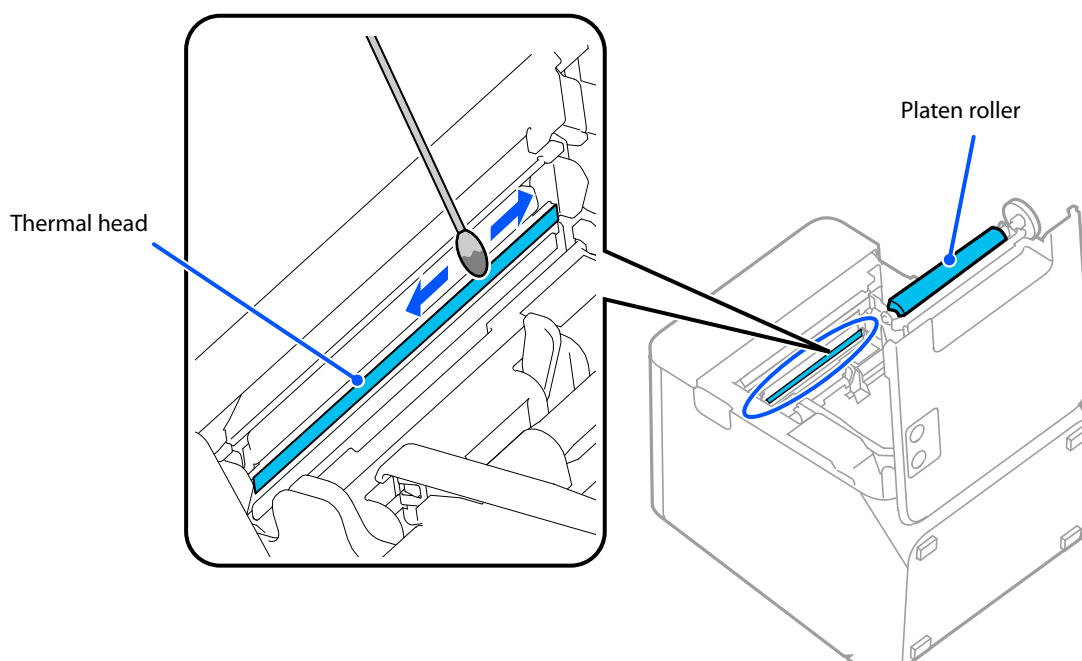

Preparing for Transport

Follow the steps below to transport the printer.

- 1** Turn off the printer.
- 2** Ensure that the POWER LED has turned off.
- 3** Disconnect the AC cable.
- 4** Remove the roll paper.
- 5** Pack the printer upright.

Checking the Nameplate

The nameplate is affixed to the side of the printer.

It shows the product name, model number, and serial number.

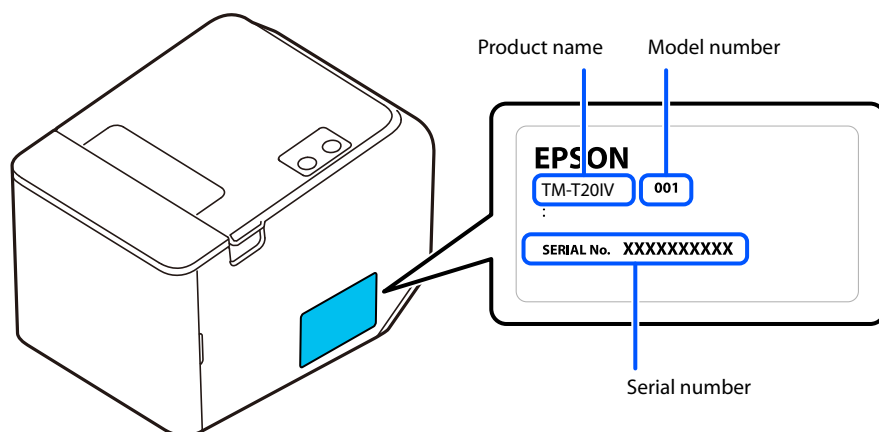

Precautions when Using the Printer as a Self-Service Terminal

When using this printer as a self-service terminal, ensure that there is at least 10 mm of space above the paper exit. If the paper exit is completely blocked, a paper jam may occur.

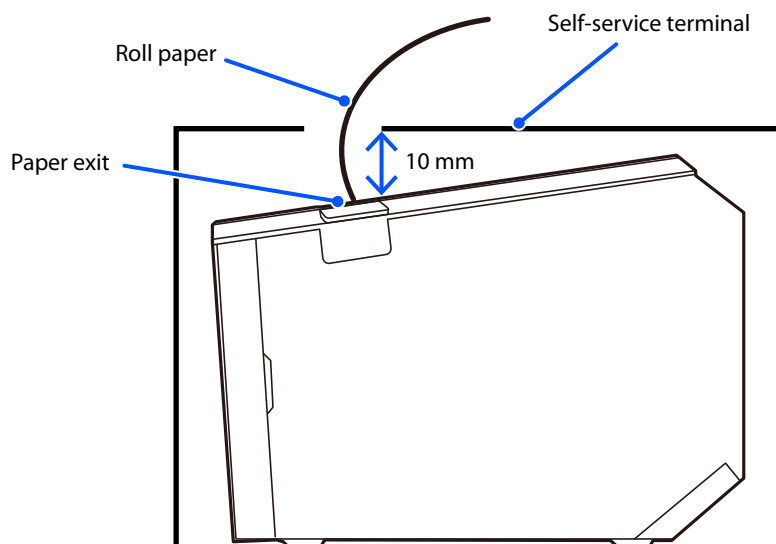

Replacement of the TM-T20III

The TM-T20IV is designed so that it can smoothly replace the TM-T20III. This chapter describes precautions for the replacement.

Compatibility

Printing

The printing and character specifications are the same as those of the TM-T20III. Without special configurations, the TM-T20IV prints the same results as the TM-T20III prints.

Logo Registration

The TM-T20IV can register logos in the NV memory (NVRAM) with the Setup Utilities.

Driver Compatibility

You can operate the TM-T20IV with a driver for the TM-T20III.

If Connecting as a Peripheral Device of the TM-i/DT Printer

If using this product as a network printer from a TM-i/DT printer, register it as TM-T20 series. For the registration method, see the Technical Reference Guide of the TM-i/DT printer.

Overall Dimensions

You can place the TM-T20IV in the same location as the TM-T20III, since its overall dimensions and weight are almost the same as those of the TM-T20III.

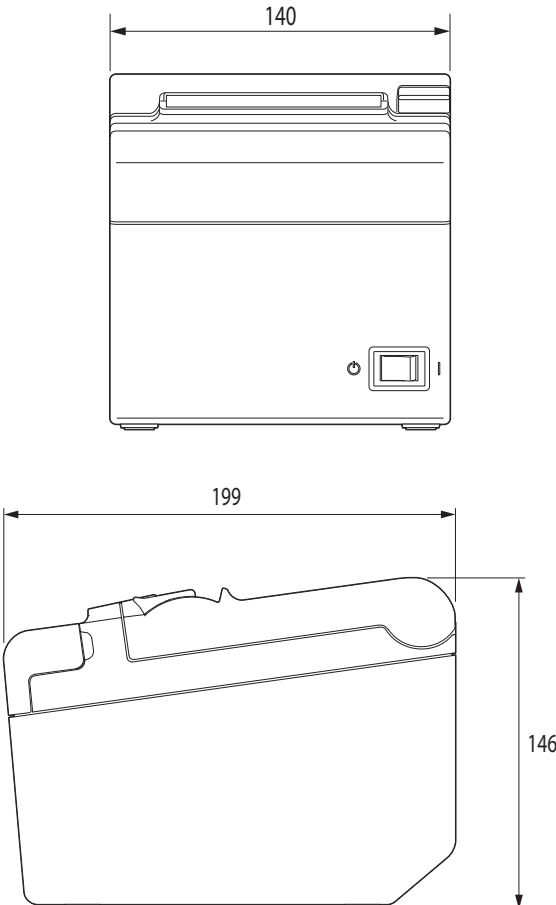
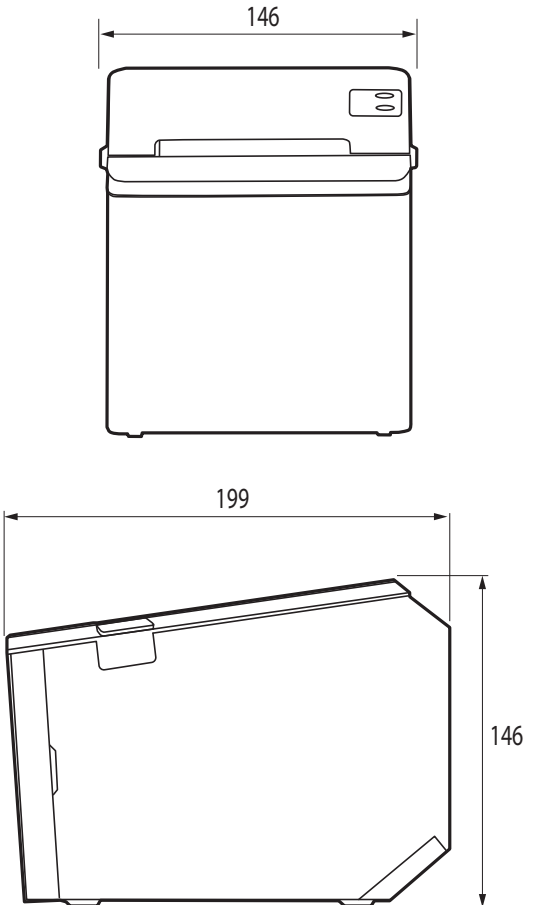
TM-T20III W:140 × D:199 × H:146 mm Approx. 1.7 kg {W:5.52 × D:7.84 × H:5.75 in. Approx. 3.75 lb}	TM-T20IV W:146 × D:199 × H:146 mm Approx. 1.7 kg {W:5.75 × D:7.84 × H:5.75 in. Approx. 3.75 lb}
	

Units: mm

Appendix

Product Specifications

Printing method		Thermal line printing
Paper feed speed		Approx. 200 mm/s {approx. 7.88 in./s} (continuous paper feeding with the Feed button)
Cutting Method		Partial cut (cutting with one point at left uncut)
Interface	USB/Serial model	USB: USB (Type-B) Serial: RS-232 (25 pin)
	USB/Ethernet/Serial model	USB: USB (Type-B) Ethernet: 10BASE-T/100BASE-TX Serial: RS-232 (9 pin) Wireless LAN: Connects an optional Wireless LAN unit to the USB (Type-A) connector.
Buffers	Receive buffer	4 KB or 128 KB (Default: 4 KB)
	Downloaded buffer	Approx. 12 KB (both for user-defined characters and downloaded images)
	NV graphics data	256 KB
	Downloaded graphics data	208 KB
Barcode/two-dimensional symbol/ composite symbol printing		UPC-A, UPC-E, JAN 8 (EAN 8), JAN 13 (EAN 13), CODE 39, ITF, CODABAR (NW-7), CODE 93, CODE 128, CODE 128 auto, GS1-128, GS1 DataBar Omnidirectional, GS1 DataBar Truncated, GS1 DataBar Stacked, GS1 DataBar Stacked Omnidirectional, GS1 DataBar Limited, GS1 DataBar Expanded, GS1 DataBar Expanded Stacked, PDF417, QR CODE, MaxiCode, Composite Symbology, Aztec Code, DataMatrix
Drawer kick connector drive function		2 drives
Power supply		Power supplied by the specified AC adapter
AC power consumption (100 to 230V/50 to 60 Hz)* ¹	Operating	Approx. 27.2 W
	Standby	Approx. 0.96 W
Life* ²	Mechanism	15 million lines
	Thermal head	150 km {93.2 miles}
	Autocutter	2,000,000 cuts
MTBF* ³		360,000 hours
MCBF* ⁴		60,000,000 lines
Temperature/humidity		Operating: 5 to 45°C {41 to 113°F}, 10 to 90% RH Storage: -10 to 50°C {14 to 122°F}, 10 to 90% RH
Overall dimensions (W × D × H)		146 × 199 × 146 mm {5.75 × 7.84 × 5.75 in.}
Weight		Approx. 1.7 kg {3.75 lb} (roll paper excluded)

*1: According to our operation conditions. It may differ depending on the usage conditions and product model.

*2: Indicates the point at which the wear-out failure period starts.

*3: Indicates the mean time between failures during the random failure period.

*4: Indicates the overall mean time between failures, including wear-out and random failures, before the life is reached.

Printing Specifications

			80 mm {3.15 in.} wide paper	58 mm {2.28 in.} wide paper
Printing method			Thermal line printing	
Paper feed direction			Unidirectional with friction feed	
Dot density			203 × 203 dpi	
Printing width	Standard mode (default setting)		72.0 mm {2.83 in.}, 576 dots	52.5 mm {2.07 in.}, 420 dots
	42 column mode		68.3 mm {2.69 in.}, 546 dots	47.3 mm {1.86 in.}, 378 dots
Characters per line	Standard mode (default setting)	Font A	48	35
		Font B	64	46
	42 column mode	Font A	42	42
		Font B	60	31
Character spacing	Standard mode (default setting)	Font A	0.25 mm {0.0098 in.}, 2 dots	
		Font B	0.25 mm {0.0098 in.}, 2 dots	
	42 column mode	Font A	0.38 mm {0.015 in.}, 3 dots	0.25 mm {0.0098 in.}, 2 dots
		Font B	0.25 mm {0.0098 in.}, 2 dots	0.25 mm {0.0098 in.}, 2 dots
Line spacing			3.75 mm {0.15 in.} (default setting, programmable by command)	
Maximum print speed*			250 mm/s {9.84 in./s}*	

dpi: dots per inch

*: The maximum is 100 mm/s {3.94 in./s} when printing ladder barcodes or two-dimensional symbols.

NOTE

Printing speed may be slower depending on the data transfer rate and other factors. Also, the maximum print speed is the speed when the printer prints at standard print density at 24 V in an environment of 25°C {77°F}.

Character Specifications

			80 mm {3.15 in.} wide paper	58 mm {2.28 in.} wide paper
Number of characters			Single-byte code characters <ul style="list-style-type: none"> • Alphanumeric characters: 95 characters • Extended graphics: 128 characters × 43 pages (including user-defined page) • International characters: 18 sets 	
Character structure (W × H dots)	Standard mode (default setting)	Font A	12 × 24 (Right-side dot space: 2)	
		Font B	9 × 17 (Right-side dot space: 2)	
	42 column mode	Font A	13 × 24 (Right-side dot space: 3)	9 × 17 (Right-side dot space: 2)
		Font B	9 × 17 (Right-side dot space: 2)	12 × 24 (Right-side dot space: 2)
Character size *	Standard mode (default setting)	Font A	1.25 × 3.00 mm {0.05 × 0.12 in.}	
		Font B	0.88 × 2.13 mm {0.03 × 0.08 in.}	
	42 column mode	Font A	1.25 × 3.00 mm {0.05 × 0.12 in.}	0.88 × 2.13 mm {0.03 × 0.08 in.}
		Font B	0.88 × 2.13 mm {0.03 × 0.08 in.}	1.25 × 3.00 mm {0.05 × 0.12 in.}

*: Space between characters is not included. Characters can be scaled up to 64 times as large as the standard size.

NOTE

See the Character Code Tables for TM Printers that can be accessed from the following URL:
https://support.epson.net/publist/reference_en/

Paper Specifications

	80 mm {3.15 in.} width paper	58 mm {2.28 in.} width paper	
Paper types	Specified thermal paper		
Form	Roll paper		
Size	Roll paper diameter	Max.: 83 mm {3.27 in.}	
	Roll paper spool	Inside: 12 mm {0.47 in.}, Outside: 18 mm {0.71 in.}	
	Roll width when taken up	80 + 0.5/-1.0 mm {3.15 +0.02/-0.04 in.}	58 + 0.5/-1.0 mm {2.28 +0.02/-0.04 in.}
	Paper width	79.5 ± 0.5 mm {3.13 ±0.02 in.}	57.5 ± 0.5 mm {2.26 ±0.02 in.}
	Paper thickness	Maximum of 75 µm, minimum of 53 µm	
Specified original paper type	NTP080-80	NTP058-80	
Specified original paper type	TF50KS-EY, TF60KS-E (NIPPON Paper Industries Co., Ltd.) PD160R, PD190R (Oji Imaging Media Co., Ltd.) P220AGB-1 (Mitsubishi Paper Mills Limited.) JujoP-KSND-55, JujoP-KSND-48 (Jujo Thermal Oy) P5047(55) (Mitsubishi HiTec Paper Flensburg GmbH) KT55FA, KT48FA, KT55PF, KT48PF (Papierfabrik August Koehler SE) Epson Certified Media List for Thermal Receipt Printers  https://support.epson.net/publist/bsredirect.php?code=M001035		

CAUTION

- Paper must not be pasted to the roll paper spool.
- For the best print quality for each paper type, it is recommended to set the print density. (See "Software Settings" on page 45.)
- Use of thermal paper with a pre-printed recording surface should be avoided. Using it can cause the thermal head to stick to the thermal paper surface during printing, and cause printing failure and other problems. The pre-printing also can result in reduced print density. Using thermal paper with a pre-printed recording surface, pre-printing should be done in accordance with the conditions (ink type, printing and other conditions) recommended by the paper manufacturer, and the thermal paper should be checked to ensure that there is no faulty printing, loss of print density, or other problems.

Printable Area

80 mm {3.15 in.} wide paper printing

The maximum printable area of paper with a width of 79.5 ± 0.5 mm { 3.13 ± 0.02 in.} is 72.0 ± 0.2 mm { 2.83 ± 0.008 in.} (576 dots) and the approximate space is 3.0 mm {0.12 in.} on the left side and 4.5 mm {0.18 in.} on the right side.

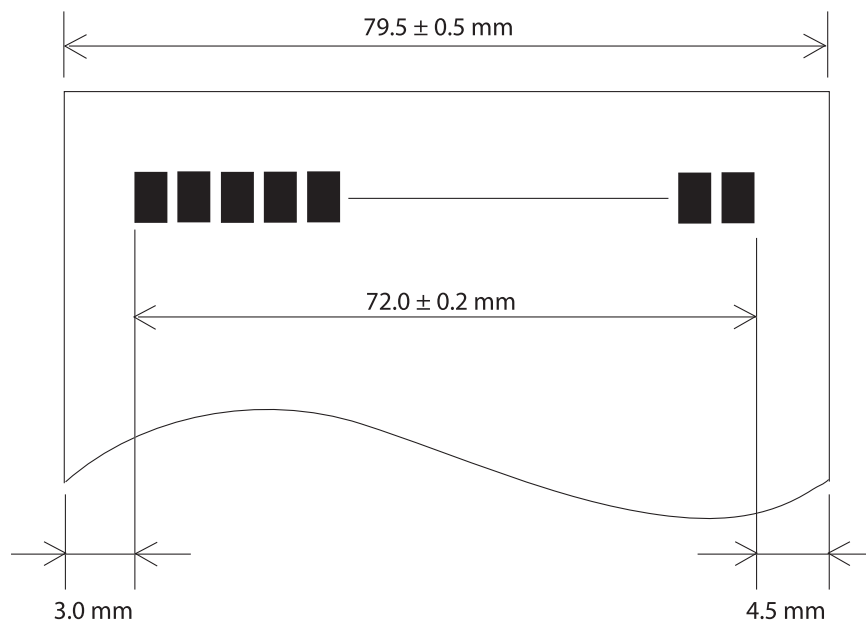

58 mm {2.28 in.} wide paper printing

The maximum printable area of paper with a width of 57.5 ± 0.5 mm { 2.26 ± 0.02 in.} is 52.5 ± 0.2 mm { 2.07 ± 0.008 in.} (420 dots), and the approximate space is 3.0 mm {0.12 in.} on the left side and 2.0 mm {0.079 in.} on the right side.

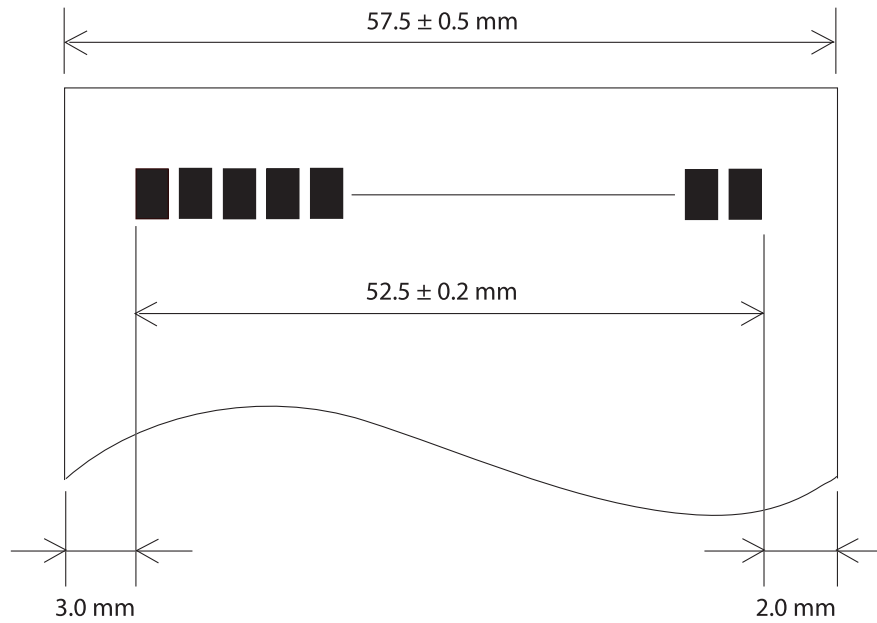

Printing and Cutting Positions

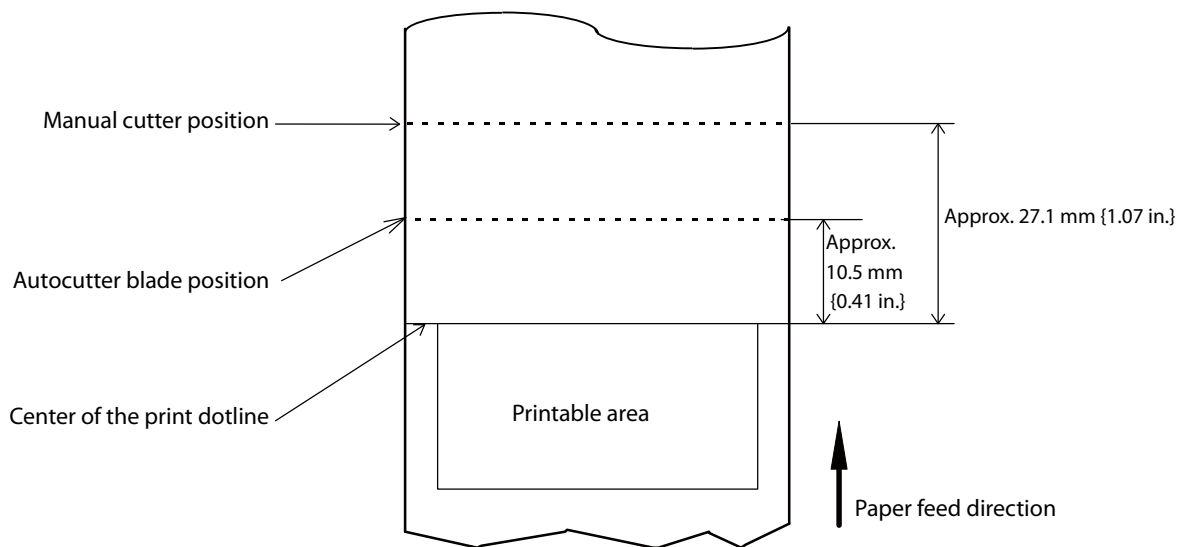

CAUTION

- The values above may vary slightly as a result of paper slack or variations in the paper. Take this into account when setting the cutting position of the autocutter.
- When removing cut paper, the remaining roll paper is pulled at the uncut section and the pitch of the next print may be reduced. When printing after cutting paper for prints with no pitch reduction, feed the paper about 1 mm {16/406 inches} before printing.
- When leaving paper loaded for an extended period of time, make sure you feed about 40 mm of paper. This can prevent paper from wrinkling and causing prints to be too light.

Electrical Characteristics

Supply voltage	DC24 V±7%
Rated current	1.5 A

CAUTION

If printing is continuously performed with a high print ratio, the overcurrent protection may be activated and result in uneven print density or a low voltage error. Therefore, the printing length must not exceed the following values when printing with high print ratio.

Print ratio: Number of dots being energized per one dot line / Total number of dots per one dot line
 The total number of dots per dot line is 420 dots when printing on 58 mm {2.28 in.} wide paper and 576 dots when printing on 80 mm {3.15 in.} wide paper.

Print ratio	80%	100%
Print example		
Print length	30 mm {1.18 in.}	20 mm {0.79 in.}

Environmental Conditions

Temperature/ Humidity	Operating	5 to 45°C {41 to 113°F}, 10 to 90% RH (See the operating environment range below.)
	Storage	-10 to 50°C {14 to 122°F}, 10 to 90% RH (except for paper)
		<p>Relative humidity ↑</p> <p>Operating environment range</p> <p>→ Ambient temperature</p>
Vibration resistance	When packed	<p>Frequency: 5 to 55 Hz</p> <p>Acceleration: Approximately 19.6 m/s² {2 G}</p> <p>Sweep: 10 minutes (half cycle)</p> <p>Time: 1 hour</p> <p>Orientation: x, y, and z</p> <p>There is no external or internal visible damage and the unit operates normally after being subjected to vibration.</p>
Impact resistance	When packed	<p>Packing: Epson standard package specifications</p> <p>Height: 60 cm {23.62 in.}</p> <p>Orientation: 1 corner, 3 edges, and 6 surfaces</p> <p>There is no external or internal visible damage and the unit operates normally after being dropped.</p>
	When unpacked	<p>Height: 5 cm {1.97 in.}</p> <p>Orientation: Lift one edge and release it (for all 4 edges)</p> <p>There is no external or internal visible damage and the unit operates normally after being dropped while not operating.</p>
Acoustic noise	(operating)	<p>Approx. 55 dB (bystander position)</p> <p>Note: The values above are measured in the Epson evaluation condition.</p> <p>Acoustic noise differs depending on the paper used, printing contents, and the setting values, such as print speed or print density.</p>

External Dimensions and Weight

- Width: Approx. 146 mm {5.75 in.}
- Depth: Approx. 199 mm {7.84 in.}
- Height: Approx. 146 mm {5.75 in.}
- Weight: Approx. 1.7 kg {3.75 lb} (excluding roll paper)

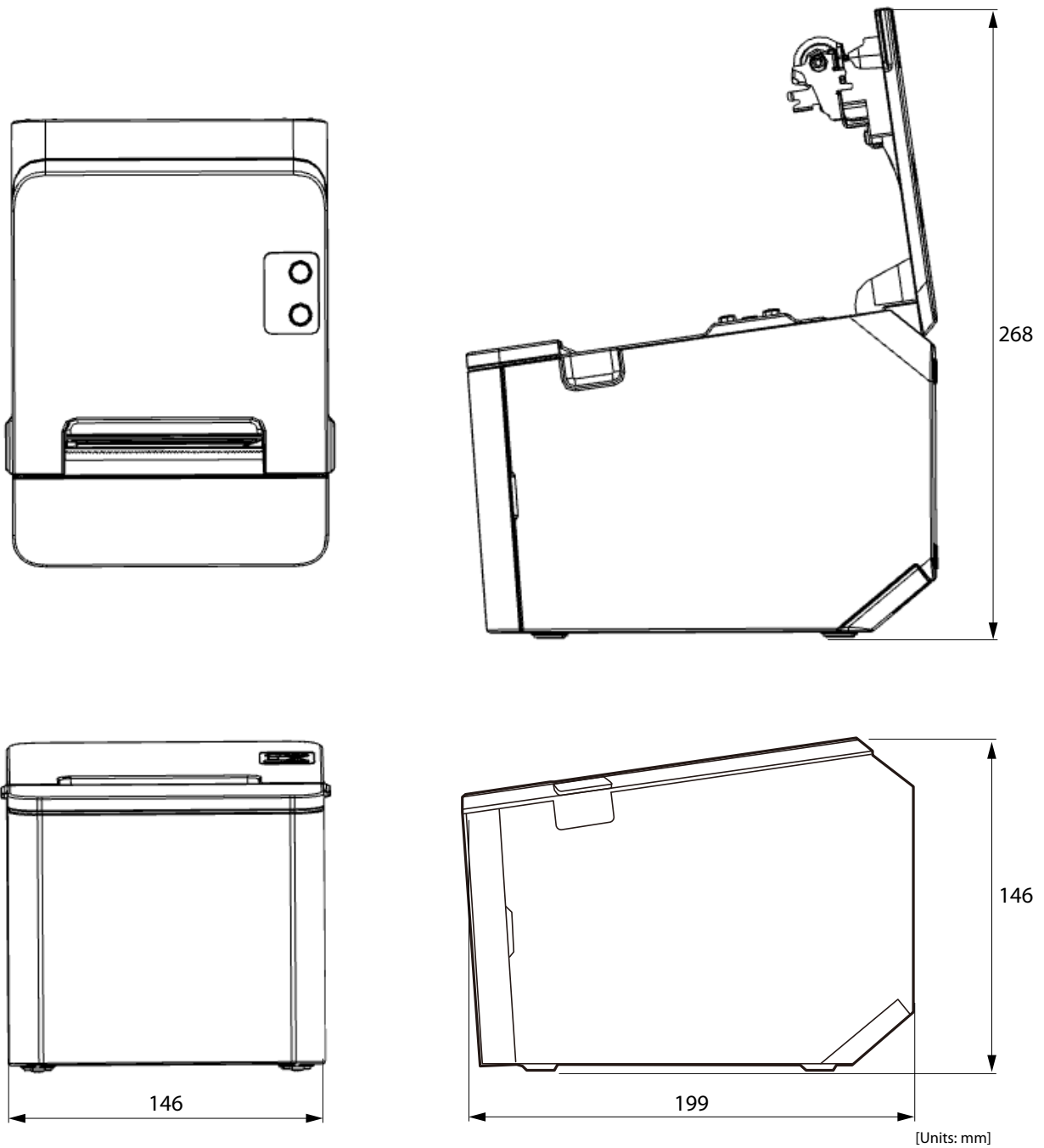

Specifications of Interfaces and Connectors

USB Interface

The printer is equipped with the following USB interfaces.

- USB-A connector
- USB-B connector

CAUTION

- Use a USB cable that complies with the USB 2.0 standard. Using a non-compliant cable may cause the printer to malfunction due to static electricity.
- Do not apply excessive force to the connectors. Doing so may damage the connectors.

USB-A Connector Specifications

On-board connector: USB Standard-A connector

Item		Specifications
USB communication	Version	USB 2.0
	Transfer rate	High Speed (480 Mbps)
USB power supply	Voltage	5 V
	Supply current	Up to 0.5 A

USB-B Connector Specifications

On-board connector: USB Standard-B connector

USB communication

Item		Specifications
Version		USB 2.0
Transfer rate		Full Speed (12 Mbps)
Communication method		USB bulk transfer
Power supply		USB self-powered function
USB bus current consumption		2 mA
USB packet size (with Full-Speed connection)	USB bulk OUT	64 bytes
	USB bulk IN	64 bytes
USB device class		Switchable between USB vendor-defined class and USB printer class. For USB device class settings, see " Software Settings " on page 45.

USB descriptor

		USB vendor-defined class	USB printer class
Vendor ID		04B8h	04B8h
Product ID		0202h	0E39h
String Descriptor	Manufacturer	EPSON	EPSON
	Product	TM-T20IV	TM-T20IV
	Serial number	Character string based on the product serial number	Character string based on the product serial number

RS-232 Serial Interface

Specifications (RS-232-compliant)

Item		Specifications
Data transfer method		Serial
Synchronization		Asynchronous
Handshaking		Select one of the following in the software setting mode. <ul style="list-style-type: none"> • DTR/DSR • XON/XOFF
Signal level	MARK	-3V to -15V logic "1"/OFF
	SPACE	+3V to +15V logic "0"/ON
Bit length		Select one of the following in the software setting mode. <ul style="list-style-type: none"> • 7 bit • 8 bit
Transmission speed		Select one of the following in the software setting mode. 2400/4800/9600/19200/38400/57600/115200 bps [bps: bits per second]
Parity check		Select one of the following in the software setting mode. <ul style="list-style-type: none"> • Yes • No
Parity selection		Select one of the following in the software setting mode. <ul style="list-style-type: none"> • Even • Odd
Stop bit		1 or more bits However, the stop bit for data transfer from the printer is fixed to 1 bit.
Connector	Printer side	USB/Serial model: D-SUB 25 pin (female) USB/Ethernet/Serial model: D-SUB 9 pin (male)

Functions of each connector pin (D-SUB25)

Pin no.	Signal name	Signal direction	Function
1	FG	-	Frame ground
2	TXD	Output	Transmission data
3	RXD	Input	Reception data
4	RTS	Output	Equivalent to DTR signal (pin 20)
6	DSR	Input	<p>This signal indicates whether the host computer can receive data. SPACE indicates that the host computer can receive data. MARK indicates that the host computer cannot receive data.</p> <p>When DTR/DSR control is selected, the printer transmits data after confirming this signal. (except if transmitted using some ESC/POS commands).</p> <p>When XON/XOFF control is selected, the printer does not check this signal.</p> <p>When you use this signal as the printer's reset signal, the printer is reset when the signal remains MARK for a pulse width of 1 ms or more.</p>
7	SG	-	Signal ground
20	DTR	Output	<p>1) When DTR/DSR control is selected, this signal indicates whether the printer is BUSY.</p> <ul style="list-style-type: none"> • SPACE status Indicates that the printer is ready to receive data. • MARK status Indicates that the printer is BUSY. Select the BUSY condition in the software setting mode. <p>2) When XON/XOFF control is selected, this signal indicates that the printer is properly connected and ready to receive data from the host.</p> <ul style="list-style-type: none"> • SPACE status The signal indicates that the printer is properly connected and ready to receive data from the host. The signal is always SPACE, except in the following cases: • During the period from when power is turned on to when the printer is ready to receive data. • While the self-test is in progress.
25	INT	Input	The printer is reset if the signal remains at SPACE for a pulse width of 1 ms or more.

Functions of each connector pin (D-SUB9)

Pin no.	Signal name	Signal direction	Function
2	RXD	Input	Reception data
3	TXD	Output	Transmission data
4	DTR	Output	<p>1) When DTR/DSR control is selected, this signal indicates whether the printer is BUSY.</p> <ul style="list-style-type: none"> • SPACE status Indicates that the printer is ready to receive data. • MARK status Indicates that the printer is BUSY. Select the BUSY condition in the software setting mode. <p>2) When XON/XOFF control is selected, this signal indicates that the printer is properly connected and ready to receive data from the host.</p> <ul style="list-style-type: none"> • SPACE status The signal indicates that the printer is properly connected and ready to receive data from the host. • MARK status The signal is always SPACE, except in the following cases: <ul style="list-style-type: none"> • During the period from when power is turned on to when the printer is ready to receive data. • While the self-test is in progress.
5	SG	-	Signal ground
6	DSR	Input	<p>This signal indicates whether the host computer can receive data. SPACE indicates that the host computer can receive data. MARK indicates that the host computer cannot receive data.</p> <p>When DTR/DSR control is selected, the printer transmits data after confirming this signal. (except if transmitted using some ESC/POS commands).</p> <p>When XON/XOFF control is selected, the printer does not check this signal.</p> <p>When you use this signal as the printer's reset signal, the printer is reset when the signal remains MARK for a pulse width of 1 ms or more.</p>
7	RTS	Output	Equivalent to DTR signal (pin 4)

XON/XOFF

When XON/XOFF control is selected, the printer transmits the XON or XOFF signals as follows.

The transmission timing differs, depending on the BUSY condition.

Signal	Printer status	BUSY condition	
		Receive buffer full	Receive buffer full/ Offline
XON	When the printer goes online after turning on the power (or reset using the interface)	Transmit	Transmit
	When the receive buffer is released from the buffer full state	Transmit	Transmit
	When the printer switches from offline to online	-	Transmit
	When the printer recovers from an error using some ESC/POS commands	-	Transmit
XOFF	When the receive buffer becomes full	Transmit	Transmit
	When the printer switches from online to offline	-	Transmit

Code

The hexadecimal numbers corresponding to the XON/XOFF codes are shown below.

- XON code: 11H
- XOFF code: 13H

CAUTION

- When the printer goes from offline to online and the receive buffer is full, XON is not transmitted.
- When the printer goes from online to offline and the receive buffer is full, XOFF is not transmitted.
- When handshaking is set to DTR/DSR, XON is not transmitted as long as the printer is offline, even if a receive buffer full state has been cleared.

Network Interface

For both Ethernet interface and Wi-Fi interface

Support protocols

Protocols	Usage
IP, ARP, ICMP, UDP, TCP	Basic communication protocols
LP, LPR	Printing protocols
TCP Socket Port	Used to transfer printing data and printer status via (bidirectional) direct socket communication.
HTTP/HTTPS	Used by browsers to display and set module status
SNMP	Used by dedicated and general MIB tools to acquire and set module and printer status
ENPC	Used to acquire and set module and printer status
DHCP,	Used to acquire the IP address
APIPA	Used to assign the IP address

Network parameters

Item	Default settings
IP Address	192.168.192.168 ^{*1}
Subnet Mask	255.255.255.0 ^{*1}
Default Gateway Address	0.0.0.0 ^{*1}
IPv6 Address	Disable
Acquiring the IP Address	Auto (DHCP)
APIPA	Disable
IP Address Printing	Enable
DNS Server Address Setting	Auto
Acquire host name automatically	Manual
Host Name	No
Acquire domain name automatically	Manual
Domain Name	No
Register the network interface's address to DNS server	Manual
Administrator Name	No
Location	No
Password	***** ^{*2}
Community Name (read only)	"public"
Community Name (read/write)	No
IP Trap1 to 4	Disable
Community Name (IP Trap #1 to 4)	No
IP Trap #1 to 4 Address	0.0.0.0
Socket Timeout	90 sec

Item	Default settings
Time Server	Disable
Time Server Status	Invalid
Time Server Address	0.0.0.0
Time Server Interval	60
Time Zone	±0 (UTC)
Bonjour	Enable
SLP	Enable
LLTD	Enable
LLMNR	Enable
SSL Encryption Strength	128 bit
TLS1.0	Disable
TLS1.1	Disable
TLS1.2	Enable
https redirect	Enable
MAC Address	(Refer to MAC Address Label)

*1: Initial value when "IP address acquisition" is set to "Manual."

*2: You can find the initial password as described below.

If the product has a password label attached, the initial password is on the label.

If there is no password label attached to the product, the initial password is the product serial number.

Printing communication protocol

- LP, LPR: Transfers printing data
- TCP Socket Port: Transfers printing data and printer status via bidirectional direct socket communication.

LP, LPR

- Max. simultaneous connections: 6
- Number of connections for which printing is available: 1 (occupied until the connection is released.)
- Time out: 90 seconds (changeable)
- Job cancel: Not available
- Banner printing: Not available

Socket communication

- Port type: TCP communication port for direct printing
- Port number: 9100
- Port communication direction: bidirectional
- Max. simultaneous connections: 6
- Number of connections for which printing is available: 1 (occupied until the connection is released.)
- Time out: 90 seconds (changeable)

For Ethernet interface

Communication specifications

10BASE-T/100BASE-TX

LED Status Indication

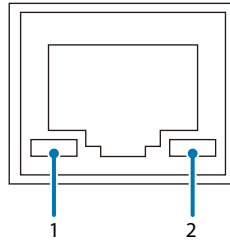

No.	LED status	Description
1	Lit green	Connecting at one of the speeds
	Blinking green	Sending/receiving data
	Off	Not connected
2	Lit orange	Connecting using 100BASE-TX
	Off	Connecting using 10BASE-T

For Wi-Fi Interface (With OT-WL06)

Countries and regions where Wi-Fi can be used are limited. Since notes are provided for each country or region, check the sheet supplied with the product.

When using wireless LAN, make sure you disconnect the LAN cable. If a LAN cable is connected, wireless LAN is disabled.

Specification

- IEEE802.11b/g/n (2.4 GHz band) or IEEE802.11a/b/g/n/ac (2.4 GHz or 5 GHz band) compliant Wi-Fi communication compatible.
- Support the IP address automatic acquisition function (DHCP, APIPA).
- Infrastructure mode is supported.

Communication Standard

- IEEE802.11b (2.4 GHz)
- IEEE802.11g (2.4 GHz)
- IEEE802.11n (2.4 GHz)
- IEEE802.11a (5 GHz)
- IEEE802.11n (5 GHz)
- IEEE802.11ac (5 GHz)

Security

Security can be selected from among the following:

- WPA-PSK(AES)
- WPA2-PSK
- WPA2-Enterprise

Settings in Standard Mode

Parameter	Setting value
Communication standard	802.11b/g/n
Network mode	Infrastructure mode
SSID	EPSON_Printer
Encryption type	WPA2-PSK
Passphrase	EpsonNet
IP Address	Automatically acquired by DHCP

Settings in SimpleAP mode (Factory default settings)

Parameter	Setting value
SSID	DIRECT-"TM-T20IV"-serial number"
Passphrase	See "Default administrator password for setting" on page 106
IP Address	192.168.223.1 or 172.16.10.1

Parameter	Setting value
Subnet mask	255.255.255.0

* In SimpleAP mode, DHCP Server is working and assigns IP address to host automatically.

Notes on Using the Wi-Fi interface

- Keep the printer away from the devices, such as kitchen microwaves, that may cause radio wave interference.
- Use channels that are away from the frequency bands that may cause radio wave interference.
- Place shields between the printer and the devices that may cause radio wave interference.
- Select either 2.4 GHz or 5 GHz, whichever is free from radio wave interference.
- In auto channel setting for the access point, do not select a channel in which the devices may cause radio wave interference.

Notes on Wi-Fi connection

Because not all the combinations of the printer and Wireless LAN units have been checked for operation, the operation of the printer in combination with all the Wireless LAN units is not guaranteed. Especially in the adhoc mode, the printer may not operate normally, depending on the combination of the device to connect with. Be sure to carry out evaluation of the operation before use.

Notes on use

- When you initialize or change the printer settings, the printer is reset to reflect the settings. It may take about one minute depending on the network settings or environment. Also, your application may indicate power off during the time waiting for reset. In that case, wait for about one minute, and then reconnect to the printer.
- In areas where Wi-Fi communication is congested, your application may erroneously recognize that communication is disconnected and indicate power off due to response delay. Also, depending on the combination with the access point used, Wi-Fi communication performance may be degraded. Both of these issues may be improved by disabling the Wi-Fi power saving function (Power Save). However, since the power saving function is disabled, the printer will consume more power. The setting can be changed using Web Config or TM-T20IV Utility.

Default administrator password for setting

The default password and the passphrase are as follows:

Password label	Password
Attached on the product	Printed on the label
Not attached on the product	Product serial number (10-digit alphanumeric characters, case-sensitive)

The password label is attached at the location shown below.

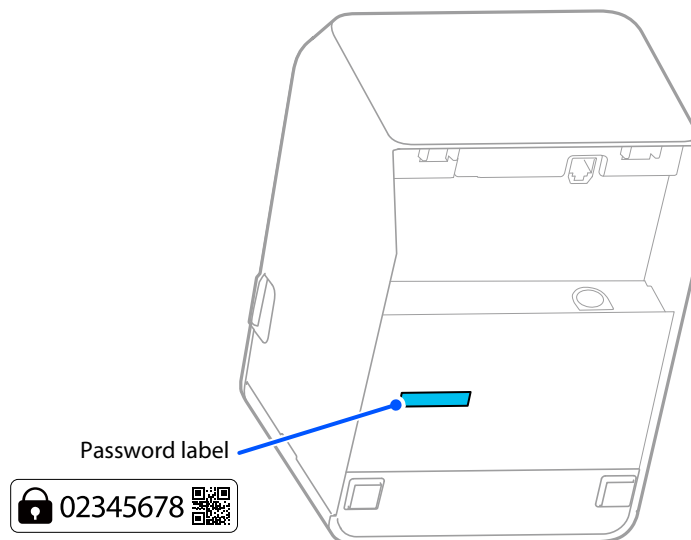

The product's serial number can be found on the nameplate. See "[Checking the Nameplate](#)" on page 82 for the location of the nameplate.

You can also check the product's serial number using a self-test ("[Self-test Mode](#)" on page 54).

If the password label is lost, the default password can be checked by printing the status sheet.

```
*** Wi-Fi & Ethernet Interface ***

Wi-Fi Status
MAC Address : Unmounted
:
:

Ethernet Status
MAC Address : XX-XX-XX-XX-XX-XX
:
:

Network
Soft Version : XX.XX(XXXX.XX.XX)

TCP/IP Status
Acquiring : Auto
:
:

Other Status
TimeServer : Invalid
Stored Date/Time : 20XX/XX/XX 00:00:00
Wi-Fi Device ID : Unknown
Wi-Fi Region ID : 0
Initial Password : XXXXXXXX
```

To improve security, it is recommended to change the administrator password from the default password. The password can be changed using Web Config, TM-T20IV Utility, or Epson TM Utility.