

TM-T82X-II

Technical Reference Guide

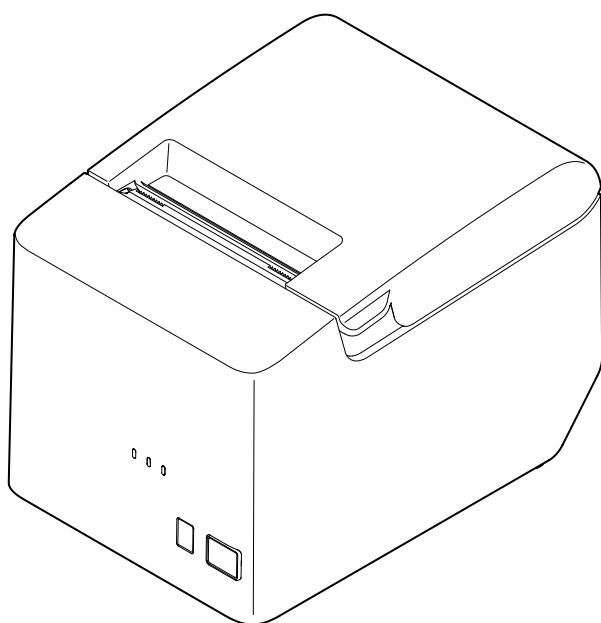

Product Overview

Describes features of the product.

Setup

Describes setup and installation of the product and peripherals.

Advanced Usage

Describes advanced usage methods for the product.

Application Development Information

Describes how to control the printer and necessary information when you develop applications.

Handling

Describes how to handle the product.

Appendix

Describes general specifications and character code tables.

Cautions

- No part of this document may be reproduced, stored in a retrieval system, or transmitted in any form or by any means, electronic, mechanical, photocopying, recording, or otherwise, without the prior written permission of Seiko Epson Corporation.
- The contents of this document are subject to change without notice. Please contact us for the latest information.
- While every precaution has been taken in the preparation of this document, Seiko Epson Corporation assumes no responsibility for errors or omissions.
- Neither is any liability assumed for damages resulting from the use of the information contained herein.
- Neither Seiko Epson Corporation nor its affiliates shall be liable to the purchaser of this product or third parties for damages, losses, costs, or expenses incurred by the purchaser or third parties as a result of: accident, misuse, or abuse of this product or unauthorized modifications, repairs, or alterations to this product, or (excluding the U.S.) failure to strictly comply with Seiko Epson Corporation's operating and maintenance instructions.
- Seiko Epson Corporation shall not be liable for any damages or problems arising from the use of any options or any consumable products other than those designated as Genuine Epson Products or Epson Approved Products by Seiko Epson Corporation.

Trademarks

Microsoft and Windows are registered trademarks of Microsoft Corporation in the United States and/or other countries.

IOS is a trademark or registered trademark of Cisco in the U.S. and other countries and is used under license.

Android™ is a trademark of Google LLC.

QR Code is a registered trademark of DENSO WAVE INCORPORATED in Japan and in other countries.

All other trademarks are the property of their respective owners and used for identification purpose only.

ESC/POS Command System



Epson ESC/POS is a proprietary POS printer command system that includes patented or patent-pending commands. ESC/POS is compatible with most Epson POS printers and displays. ESC/POS is designed to reduce the processing load on the host computer in POS environments. It comprises a set of highly functional and efficient commands and also offers the flexibility to easily make future upgrades.

©Seiko Epson Corporation 2024–2026

For Safety

Key to Symbols

The symbols in this manual are identified by their level of importance, as defined below. Read the following carefully before handling the product.

 WARNING	You must follow warnings carefully to avoid serious bodily injury.
 CAUTION	Provides information that must be observed to prevent damage to the equipment or loss of data. <ul style="list-style-type: none">• Possibility of sustaining physical injuries.• Possibility of causing physical damage.• Possibility of causing information loss.
CAUTION	Provides information that must be observed to avoid damage to your equipment or a malfunction.
NOTE	Provides important information and useful tips.

Warnings

 WARNING	<ul style="list-style-type: none">• To avoid risk of electric shock, do not set up this product or handle cables during a thunderstorm• Never insert or disconnect the power plug with wet hands. Doing so may result in severe shock.• Handle the power cable with care. Improper handling may lead to fire or electric shock.<ul style="list-style-type: none">* Do not modify or attempt to repair the cable.* Do not place any heavy object on top of the cable.* Avoid excessive bending, twisting, and pulling.* Do not place the cable near heating equipment.* Check that the plug is clean before plugging it in.* Be sure to push the plug all the way in.• Be sure to use the specified power source. Connection to an improper power source may cause fire or shock.• Do not place multiple loads on the power outlet. Overloading the outlet may lead to fire. Plug the power cord directly into the household power outlet (AC100 to 240 V).• Shut down your equipment immediately if it produces smoke, a strange odor, or unusual noise. Continued use may lead to fire. Immediately unplug the equipment and contact qualified service personnel.• Never attempt to repair this product yourself. Improper repair work can be dangerous.• Never disassemble or modify this product. Tampering with this product may result in injury or fire.• Do not allow foreign matter to fall into the equipment. Penetration by foreign objects may lead to fire.
---	---



- If water or other liquid spills into this equipment, do not continue to use it. Continued use may lead to fire. Unplug the power cord immediately and contact qualified service personnel.
- Do not use aerosol sprayers containing flammable gas inside or around this product. Doing so may cause fire.

Cautions



- Do not connect cables in ways other than those mentioned in this manual. Different connections may cause equipment damage or fire.
- Be sure to set this equipment on a firm, stable, horizontal surface. The product may break or cause injury if it falls.
- Do not use this product in locations subject to high humidity or dust levels. Excessive humidity and dust may cause equipment damage or fire.
- Do not place heavy objects on top of this product. Never stand or lean on this product. Equipment may fall or collapse, causing breakage and possible injury.
- Take care not to push your hand or finger against the manual cutter. Doing so may injure your hand or finger.
 - * When you remove printed paper
 - * When you perform other operations such as loading/replacing roll paper
- Do not open the roll paper cover without taking the necessary precautions, as this can result in injury from the autocutter fixed blade.
- To ensure safety, unplug this product before leaving it unused for an extended period.



If this product is used in a place where silicon-based gases including siloxane (silicon adhesive, silicon oil, silicon powder, etc.) or malignant gases (nitric acid, hydrogen sulfide, ammonia, chlorine, etc.) are present in the air, contact failure may occur in mechanical contacts such as mechanical switch or DC motor in a short time due to adhesion or oxidation of the insulation film.

Caution Labels

The caution labels on the product indicate the following precautions.



CAUTION:

Do not touch the thermal head and the frame on its side during or immediately after use. After printing, the thermal head and its surroundings can be very hot.

Restriction of Use

When this product is used for applications requiring high reliability/safety, such as transportation devices related to aviation, rail, marine, automotive, etc.; disaster prevention devices; various safety devices, etc.; or functional/precision devices, etc., you should use this product only after giving consideration to including fail-safes and redundancies into your design to maintain safety and total system reliability.

Because this product was not intended for use in applications requiring extremely high reliability/safety, such as aerospace equipment, main communication equipment, nuclear power control equipment, or medical equipment related to direct medical care, etc., please make your own judgment on this product's suitability after a full evaluation.

About this Manual

Aim of the Manual

This manual provides developers/engineers with all the necessary information for design, development and installation of a POS system, and also design and development of a printer application.

Manual Content

The manual is made up of the following sections:

- Chapter 1 [Product Overview](#)
- Chapter 2 [Setup](#)
- Chapter 3 [Advanced Usage](#)
- Chapter 4 [Application Development Information](#)
- Chapter 5 [Handling](#)

- Appendix [Product Specifications](#)
[Specifications of Interfaces and Connectors](#)
[Character Code Tables](#)

Contents

■ For Safety	3
Key to Symbols.....	3
Warnings	3
Cautions.....	4
■ Caution Labels	4
■ Restriction of Use	4
■ About this Manual	5
Aim of the Manual	5
Manual Content.....	5
■ Contents.....	6

Product Overview 9

■ Features	9
■ Product Configurations	10
Models.....	10
Accessories	10
■ Part Names and Functions	11
LED Lights	12
Connectors	13
■ Status and Errors	15
Online and Offline.....	15
Automatically Recoverable Errors	15
Recoverable Errors	16
Unrecoverable Errors	16
Status Display	17
■ NV Memory	18
NV Graphics Memory.....	18
User NV Memory	18
Memory Switches (Customized Value)	18
R/E (Receipt Enhancement).....	18
User-defined Page	19
Maintenance Counter.....	19
■ Printing Using Multiple Interfaces.....	20

Setup 21

■ Flow of Setup	21
■ Installing the Printer.....	22
■ Connecting the Printer to the Host.....	22

USB Interface	22
Serial Interface	23
Ethernet Interface	23
■ Connecting the AC cable	24
Connecting Procedure	24
■ Connecting the Cash Drawer	25
Cash Drawer Requirements	25
Connecting the Drawer Kick Cable	26
■ Connecting the Optional External Buzzer	27
Connecting Procedure	27
<hr/>	
<i>Advanced Usage</i>	28
■ Software Settings	28
Overview of Each Function	29
■ MAC Address Confirmation	32
■ Setting/Checking Modes	33
Self-test Mode	35
NV Graphics Information Print Mode	35
Receipt Enhancement Information Print Mode	36
Software Setting Mode	37
Restore Default Values Mode	39
Interface Setup Mode (Ethernet/USB model only)	40
Hexadecimal Dumping Mode	41
■ Printing a Status Sheet (For Ethernet/USB Model Only)	42
■ Resetting the Interface Settings	44
■ Web Config (For Ethernet/USB model only)	45
How to Start Web Config	45
What can be Configured in Web Config	45
<hr/>	
<i>Application Development Information</i>	46
■ Controlling the Printer	46
ESC/POS	46
■ Controlling the Cash Drawer	47
■ Controlling the Optional External Buzzer	48
■ Software	49
Development Kits	49
Drivers	50
Utilities	51
Others	51
Download	51

■ Notes on Printing Barcodes and Two-dimensional Symbols.....	52
---	----

Handling..... 53

■ Installing and Replacing Roll Paper.....	53
■ Removing Jammed Paper	55
When the Roll Paper Cover Cannot be Opened.....	55
■ Cleaning the Printer.....	56
Cleaning the Printer Case.....	56
Cleaning the Thermal Head/Platen Roller.....	56
■ Preparing for Transport.....	57
■ Checking the Nameplate.....	57

Appendix..... 58

■ Product Specifications	58
Printing Specifications	60
Character Specifications.....	61
Paper Specifications	62
Printable Area.....	63
Printing and Cutting Positions	64
Electrical Characteristics.....	65
Environmental Conditions.....	66
External Dimensions and Mass	67
■ Specifications of Interfaces and Connectors	68
USB Interface	68
RS-232 Serial Interface	69
Ethernet Interface.....	72
■ Character Code Tables.....	74

Product Overview

This chapter describes features of the product.

Features

Printing

High speed receipt printing is possible (250 mm/s maximum).

Handling

Easy drop-in paper loading

Software

- Command protocol is based on the ESC/POS Proprietary Command System.
- Windows printer drivers, OPOS ADK, and OPOS ADK for .NET are available.
- Printing of various types of bar codes, GS1-DataBar, and two-dimensional symbols (PDF417, QR code, MaxiCode, Composite Symbology) is supported.
- A maintenance counter function is supported.
- Multiple languages are supported for code pages, Windows drivers, and utility software.

Interface

The interface is selectable when purchasing the product.

Environment

Paper reduction function is available.

Others

Optional external buzzer is available.

Product Configurations

Models

- Serial/USB model
- Ethernet/USB model

Accessories

Included



- Roll paper (for operation check)
- Interface cable (Serial/USB model only)
- AC cable
- User's Guide

Options

External buzzer (Model: OT-BZ20)

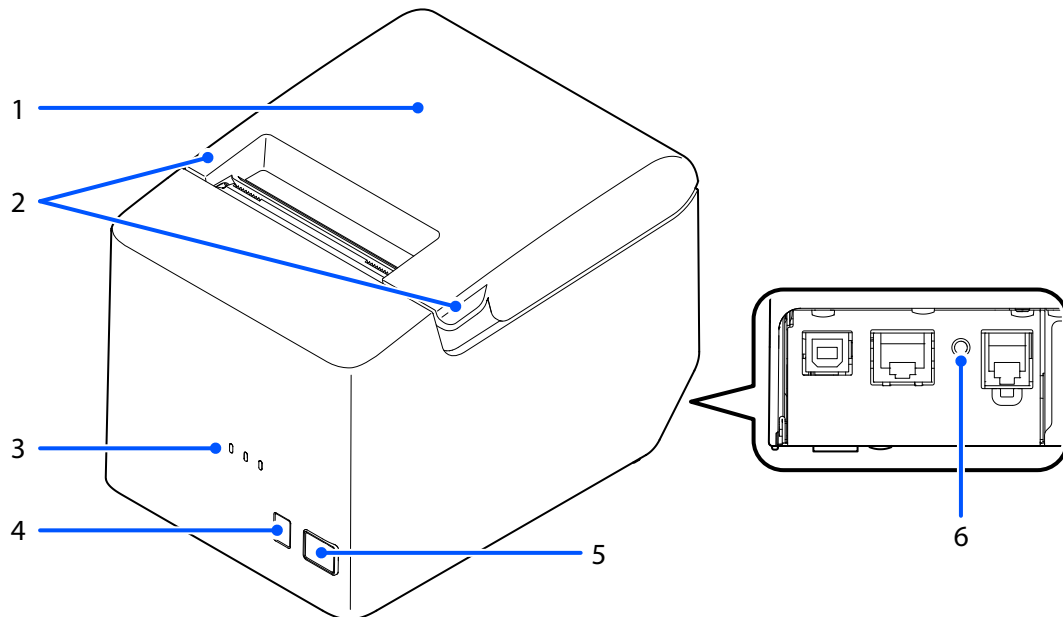
Part Names and Functions







1	Roll paper cover	Open this cover to install/replace the roll paper.
2	Cover knob	Put your finger under the knob and lift open the roller paper cover.
3	LED lights	For details on the LED lights, see " LED Lights " on page 12.
4	 Feed button	Press this button to feed the roll paper by one line. Hold down this button to feed the roll paper continuously.
5	 Power button	Press this button to turn the printer on or off.
6	Status sheet button (Ethernet/USB model only)	Press this button to print the interface status sheet, or to reset the interface settings.

NOTE

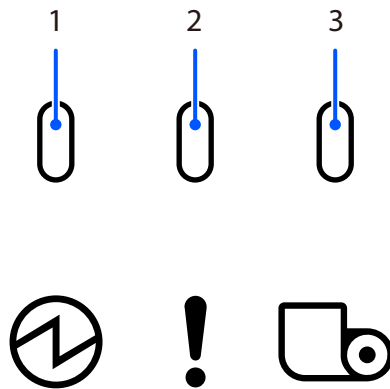
When turning off the printer without using the power button, it is recommended to send a power-off command to the printer. If you use the power-off sequence, the latest maintenance counter values are saved. (Maintenance counter values are usually saved every two minutes.) For information about ESC/POS commands, see the ESC/POS Command Reference.

LED Lights







1	 Power LED	<ul style="list-style-type: none"> • On when the printer is powered on. • Off when the printer is powered off.
2	 Error LED	<p>Lights or flashes when the printer is offline. (For information about the lighting and flashing patterns, see "Status and Errors" on page 15.)</p> <ul style="list-style-type: none"> • Lights after the power is turned on or after a reset (offline). Automatically goes out after a while to indicate that the printer is ready. • Lights when the end of the roll paper is detected, and when printing has stopped (offline). If this happens, replace the roll paper. • Off when the printer is in standard mode (online).
3	 Paper LED	<ul style="list-style-type: none"> • Lights when there is no more roll paper. • Off when there is a sufficient amount of roll paper remaining. • Flashes when a self-test is in progress or when macro execution standby state.

Connectors

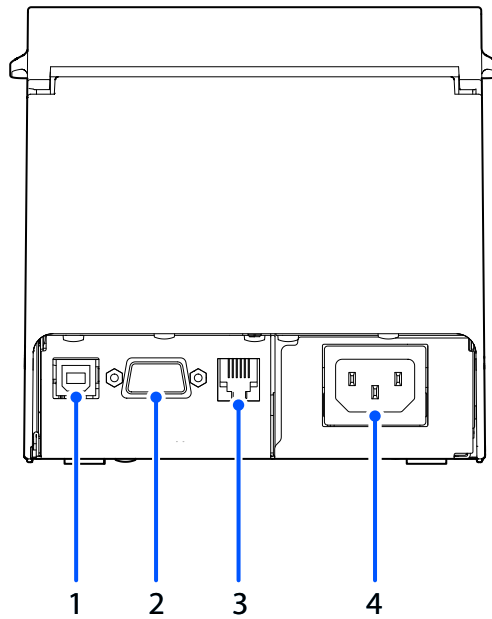
All connectors are located on the bottom back of the printer. Also, the available interfaces vary depending on the model.



Serial / USB model

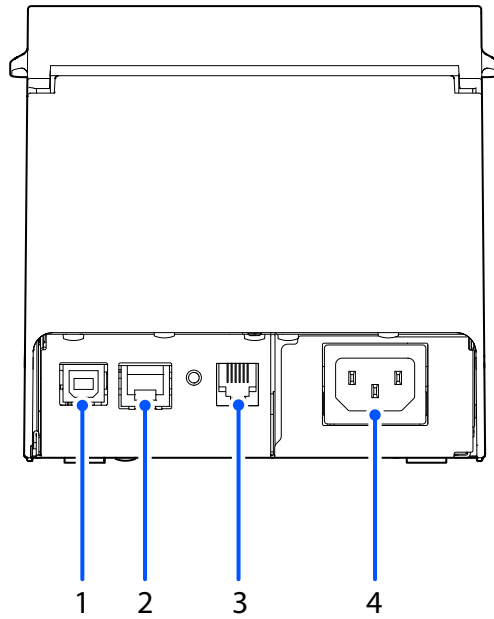

1	 USB connector	USB cable connector for connection to computer.
2	 Serial interface	Serial interface cable connector for connection to computer.
3	 DK Drawer kick connector	Cashdrawer connector or optional external buzzer connector. "Connecting the Cash Drawer" on page 25 "Connecting the Optional External Buzzer" on page 27
4	Power supply connector	AC Cable connector.

Ethernet / USB model



1	 USB connector	USB cable connector for connection to computer.
2	 Ethernet connector	Ethernet cable connector for wired network connection to computer.
3	 DK Drawer kick connector	Cashdrawer connector or optional external buzzer connector. "Connecting the Cash Drawer" on page 25 "Connecting the Optional External Buzzer" on page 27
4	Power supply connector	AC Cable connector.

Status and Errors

The LEDs light or flash to indicate the printer status.

CAUTION

The printer cannot print while an error is left unsolved.

Online and Offline

Online

The printer is online and ready for normal printing unless there is a reason to go offline.

Offline

The printer automatically goes offline under the following conditions:

- While the printer power is turning on/off
- While a self-test is running
- While roll paper is fed using the Feed button
- When the printer stops printing due to a paper end (when the paper out detector detected the paper out)
- During an operation standby state
- When an error has occurred (See ["Status and Errors" on page 15](#))
- While the roll paper cover is open

Automatically Recoverable Errors

The printer cannot print when automatically recoverable errors occur. They can be recovered easily, as described below.

Error	Error description	Error LED status	Condition for Recovery
Roll paper cover open error	The roll paper cover was opened during printing	ON	Recovers automatically when the roll paper cover is closed
Head temperature error	A high temperature outside the thermal head drive operating range was detected	ON	Recovers automatically when the thermal head cools.
Motor driver IC high temperature error	A high temperature beyond the standard range for driving the motor is detected	ON	Recovers automatically when the motor driver IC cools.

Recoverable Errors

The printer cannot print when a recoverable error occurs. It can be recovered easily by turning the power on again or sending an error recovery command from the driver after eliminating the cause of the error.

Error	Error description	Error LED status	Condition for Recovery
Autocutter error	Autocutter does not work correctly	ON	Recovers from the error when the jammed paper or foreign matter is removed, and the roll paper cover is closed.

CAUTION

The error recovery command is valid only if a recoverable error (excluding automatically recoverable errors) occurs.

NOTE

Use the TM-T82X-II Utility to change the condition for recovery. For details, see the TM-T82X-II Utility User's Manual.

Unrecoverable Errors

The printer cannot print when an unrecoverable error occurs. If the error persists after turning the printer off and then on again, the printer may require service. Contact qualified service personnel.



CAUTION

Turn off the power immediately when an unrecoverable error occurs.

Error	Error description	Error LED flash code
R/W error in memory	After R/W checking, the printer does not work correctly.	
High voltage error	The power supply voltage is extremely high.	
Low voltage error	The power supply voltage is extremely low.	
CPU execution error	The CPU is executing an incorrect address.	
Internal circuit connection error	Internal circuits are not connected correctly.	

Status Display

●: ON ● (with two dots above): Flashing ○: OFF -: Changes depending on whether or not paper is detected.

	Power LED	Error LED	Paper LED
Online	●	○	○
Initializing after power-on	●	●	-
Running a self-test	●	○	-
Waiting to continue self-test	●	○	● (with two dots above)
Feeding using the Feed button	●	○	-
Waiting to execute a macro	●	○	● (with two dots above)
Roll paper cover open while the printer is not printing	●	●	-
No paper	●	●	●
While updating firmware (Main)	●	● (with two dots above)	● (with two dots above)
While updating firmware (Boot)	●	● (with two dots above)	● (with two dots above)
Power off standing by	●	○	● (with two dots above)
The network link is down	●	● (with two dots above) *	-
Waiting to print status sheet	●	●	● (with two dots above)

*: The error LED flashing patterns are as follows.

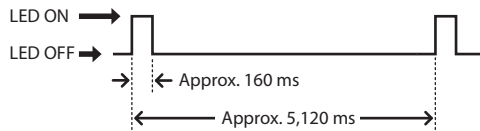

NV Memory

The printer is equipped with the NV memory (Nonvolatile Memory) to store data even after the printer power is turned off. NV memory contains the following memory areas for the user:

- NV graphics memory
- User NV memory
- Memory switches
- R/E (Receipt Enhancement)
- User-defined page
- Maintenance counter



Epson recommends that changes to NV memory be performed no more than 10 times a day, if any.

NV Graphics Memory

Graphics, such as shop logos to be printed on receipts, can be stored. Even with a serial interface model whose transmission speed is low, high speed graphics printing is possible.

TM-T82X-II Utility or ESC/POS commands can be used for the graphic registration.

TM-T82X-II Utility or NV Graphics Information Print Mode can be used for the confirmation.

User NV Memory

You can store and read text data for multiple purposes, such as for storing a note including customizing or maintenance information of the printer.

Memory Switches (Customized Value)

You can configure various settings of the printer. For more information, see "[Software Settings](#)" on page 28.

R/E (Receipt Enhancement)

Registered graphics in the NV Graphics Memory can be printed automatically, as a top logo before receipt printing or as a bottom logo before cutting paper.

TM-T82X-II Utility or ESC/POS commands can be used for the settings.

TM-T82X-II Utility or Receipt Enhancement Information Print Mode can be used for the confirmation.

User-defined Page

You can store character data in the user-defined page (character code table: page 255) so that you can also print characters not resident in the printer.

Maintenance Counter

With this function, printer information, such as the number of lines printed, the number of paper autocuts, and printer operation time after the printer starts working, is automatically stored in NV memory. You can use the counter information for periodical maintenance checks or part replacement.

NOTE

- You can also check the print head running length and number of times of auto-cutting with the self-test (see ["Self-test Mode" on page 35](#)).
- The maintenance counter value is normally saved in the NV memory every 2 minutes (maximum of 4 minutes). However, it is not automatically saved when the product is in the power-saving mode or when the power is turned off without using the power switch.

Printing Using Multiple Interfaces

The printer offers multiple interfaces and allows you to use all of them without limitation.

The printer provides each interface with an independent receive buffer and switches the active interface depending on the priority, while handling data in each receive buffer.

You can set one interface for the main connection. Data received from the main connection interface is handled with the highest priority.

By default, the interface that receives the first data transfer is set as the main connection interface; however, you can select the main connection interface in advance.

When the receive buffer for the active interface becomes empty and a preset time period has passed, switching to another interface is enabled, and an interface that receives print data becomes active.

NOTE

You can select the main connection interface and set the time to enable interface switching from the software settings. For details on software settings, see ["Software Settings" on page 28](#).

Setup

This chapter describes setup and installation of the product and peripherals.

Flow of Setup

This chapter consists of the following sections along with the setup flow of the product and peripherals.

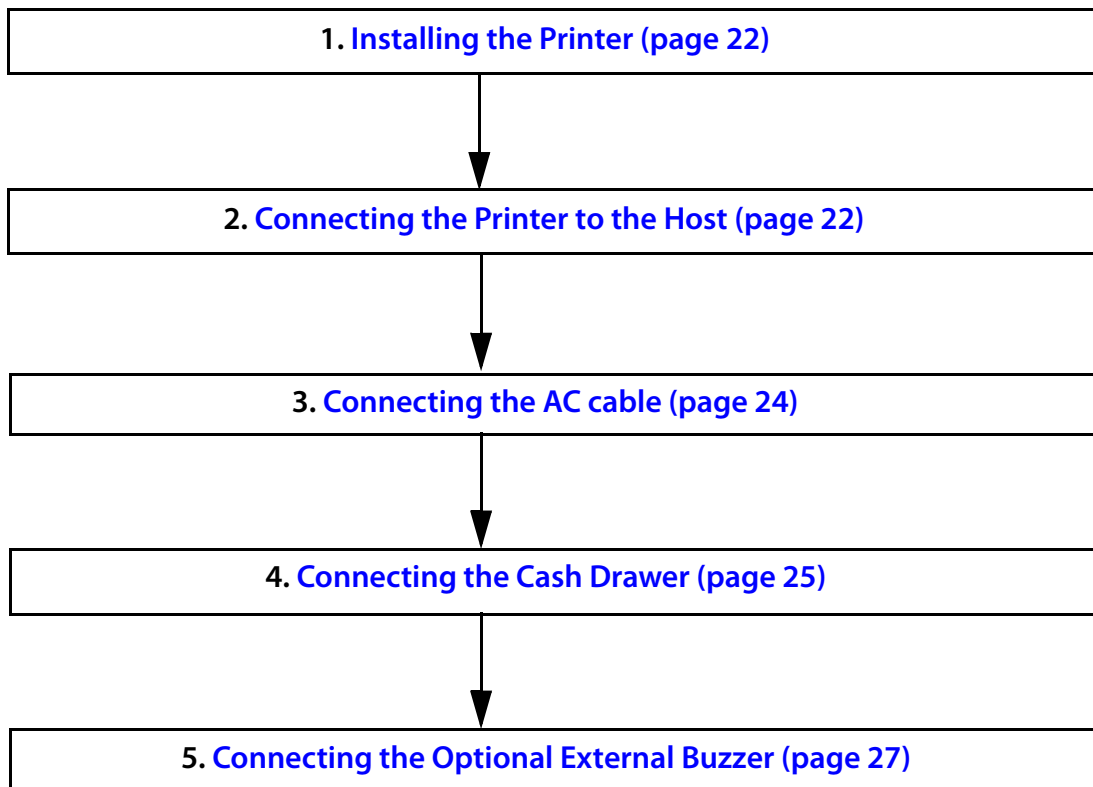

Installing the Printer

Observe the following precautions when installing the printer.

- The printer must be installed horizontally.
- Do not place the printer in a dusty location.
- Do not knock or strike the printer. This may cause defective print.
- Do not catch cables or place foreign matter under the printer.
- Take measures to prevent the printer from moving by vibration during paper cutting and when using a drawer.

Connecting the Printer to the Host

CAUTION

- Be sure to install the driver before connecting the printer to the host computer.
- The DK connector specifically designed for use with a cashdrawer or the optional external buzzer. Do not connect this connector into a wired telephone system.

USB Interface

CAUTION

- Please observe the following precautions to prevent the product from failing or malfunctioning due to static electricity or the like.
 - * If using the Serial/USB model: Be sure to use the interface cable included with the printer.
 - * If using the Ethernet/USB model: Use a USB cable compliant with the USB 2.0 standard.
- Do not place any weight or stress on the cable when using. Doing so could damage the cable and connectors.

When using USB cable to connect with host device, connect the USB cable to the printer, and after starting the host device, turn the printer on.

If you are using the Serial/USB model, you can secure the USB cable with a wire saddle to prevent it from coming out.

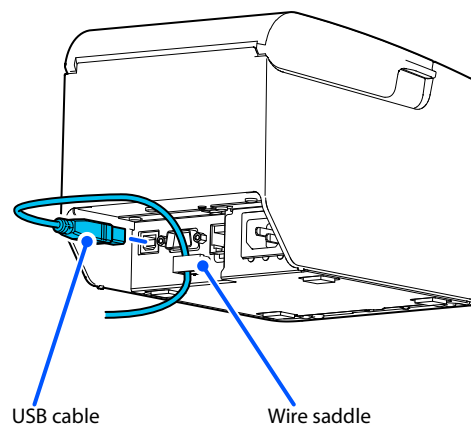

Serial Interface

When connecting to the host computer through a serial interface (RS-232), connect a serial cable to the printer, start the host computer, and then turn on the printer.

NOTE

When using connectors equipped with screws, tighten the screws on both sides to secure the connectors firmly.

Ethernet Interface

Use an Ethernet cable to connect the printer to network via a hub.

Use TM-T82X-II Utility or Web Config to set network.

For details on TM-T82X-II Utility, refer to TM-T82X-II Utility User's Manual.

For details on Web Config, refer to Web Config Reference Guide.

CAUTION

- When LAN cables are installed outdoors, make sure they are connected through devices that have surge protection. Otherwise, the devices can be damaged by lightning.
- Do not connect a telephone cable or a cashdrawer cable into the LAN port connector. Only connect ethernet LAN cables to this connector.

Connecting the AC cable



- Never insert the AC cable plug into a socket that does not meet the rated voltage requirements of the printer.
Doing so may result in damage to the printer.
- Should a fault ever occur, immediately turn off the power to the printer and unplug the AC cable from the wall socket.

Be sure to use the included AC cable.

Connecting Procedure

- 1** Make sure the printer is turned off.
- 2** Connect the AC cable to the power supply connector.

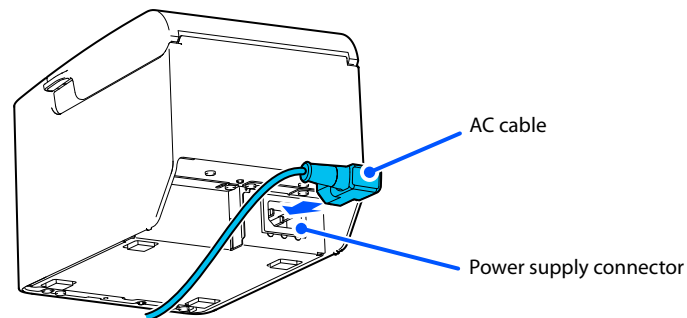

- 3** Insert the AC plug into a wall socket.

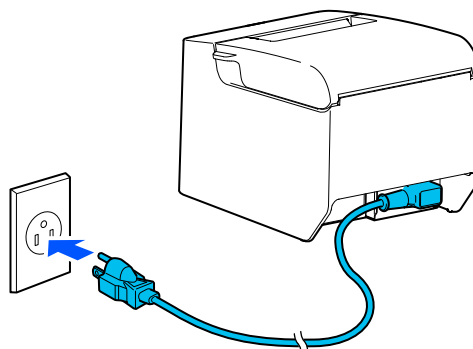

CAUTION

Do not turn on the printer before installing the printer driver.

Connecting the Cash Drawer

CAUTION

- The optional external buzzer and the cash drawer cannot be used simultaneously. Do not connect both the optional external buzzer and the cash drawer to the printer at the same time by using a branched connector.
- The cash drawer cannot be used if the enable/disable setting for the optional external buzzer is set to "enable". When using the cash drawer, be sure to set it to "disable" using the TM-T82X-II Utility.
- Two driver transistors cannot be energized simultaneously.
- Leave intervals longer than 4 times the drawer driving pulse when sending it continuously.

Cash Drawer Requirements

Specifications of drawers differ depending on makers or models. When you use a drawer other than specified, make sure its specification meets the following conditions.

Otherwise, devices may be damaged.

- The load, such as a drawer kick solenoid, must be connected between pins 4 and 2 or pins 4 and 5 of the drawer kick connector.
- When the drawer open/close signal is used, a switch must be provided between drawer kick connector pins 3 and 6.
- The resistance of the load, such as a drawer kick solenoid, must be 24 ohms or more or the input current must be 1A or less.
- Be sure to use the 24V power output on drawer kick connector pin 4 for driving the equipment.

Drawer Connection Diagram

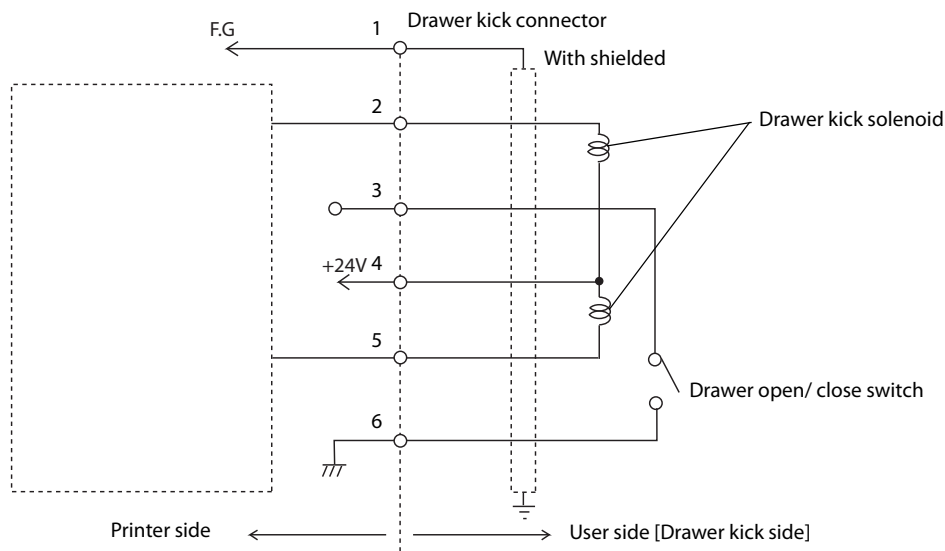

Adaptable Connector

Modular connector RJ12

Pin assignments

Pin number	Signal name	Direction
1	Frame GND	-
2	Drawer kick drive signal 1	Output
3	Drawer kick open/close signal	Input
4	+24 V	-
5	Drawer kick drive signal 2	Output
6	Signal GND	-

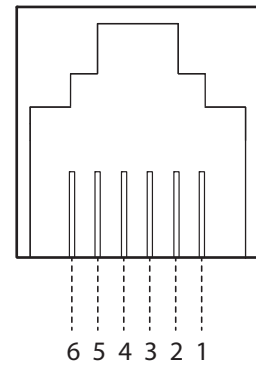

Connecting the Drawer Kick Cable



- To prevent malfunctions, use a drawer kick cable that ensures the frame ground is connected.
- The printer provides power for the cashdrawer via pin 4 of its connector. This pin should be used to power the cashdrawer.
- To prevent the possibility of damaging the printer and other devices, do not connect the DK connector to a wired telephone system.

Connect the drawer kick cable to the drawer kick connector by pressing firmly until the connector clicks into place.

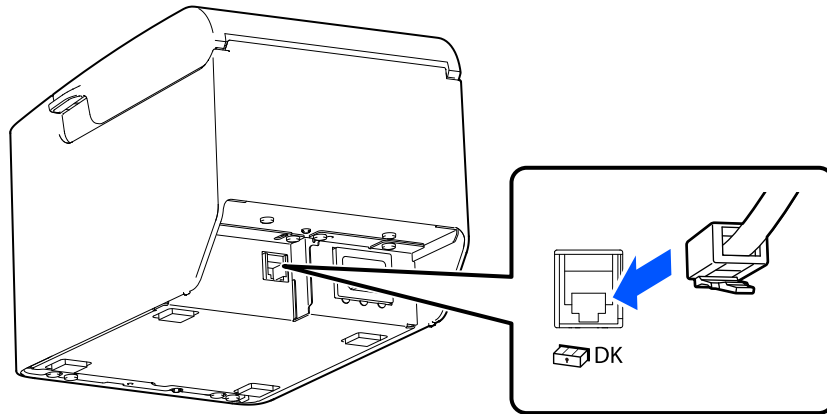

Connecting the Optional External Buzzer

When the optional external buzzer (model: OT-BZ20) is connected to the drawer kick connector of the printer, you can set the printer so that it beeps when you send commands, when an error occurs, when executed auto cutting, and when detected paper end. Settings for sound patterns and frequency depending on the occasions the buzzer beeps are also available.

Use the TM-T82X-II Utility to make the buzzer settings: enable/disable setting, sound pattern setting, and frequency setting.

CAUTION

- Be sure to turn off the printer before you connect/disconnect the optional external buzzer.
- The optional external buzzer and the cash drawer cannot be used simultaneously. Do not attempt to connect both the optional external buzzer and the cash drawer to the printer at the same time by using a "Y" split cable or adapter.

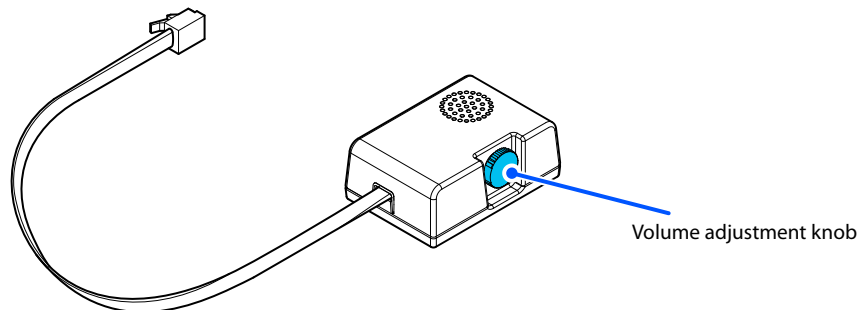

Connecting Procedure

The optional external buzzer is recommended to be installed in the following positions.

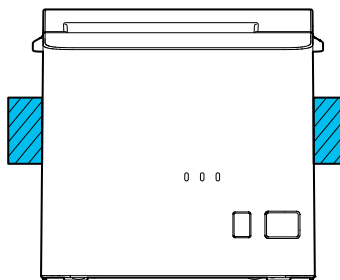

CAUTION

- Do not place the optional external buzzer where the paper exits the printer.
- To prevent liquid from entering inside, it is recommended to install the optional external buzzer so that the volume adjustment knob is positioned sideways or downward.

Advanced Usage

Software Settings

The printer offers memory switches and customized values which allow you to make various settings for the printer.

The settings can be made in any of the methods listed in the table below or by using the ESC/POS commands. For an explanation of each function and setting, see ["Overview of Each Function" on page 29](#).

Item/Method	Software Setting Mode	TM-T82X-II Utility
Serial Baud Rate	✓	✓
Serial Parity	✓	✓
Serial Handshaking	✓	✓
Serial Data Bits	✓	✓
USB Class	✓	✓
Receive Buffer Capacity	✓	✓
BUSY Condition	✓	✓
Interface Selection	✓	
Interface switch waiting time	✓	✓
Main connection interface	✓	✓
Print Density	✓	✓
Print Speed	✓	✓
Automatic Reduction of Paper	✓	✓
Code Page	✓	✓
International Character Set	✓	✓
Thai Character Composition	✓	
Column Emulation	✓	✓
Command Execution (Offline)		✓
Autocutting after closing the roll paper cover		✓
Buzzer function		✓
Shrinking/Expanding graphics data		✓
Autocutter error recovery condition		✓
Auto top logo printing		✓
Auto bottom logo printing		✓
Extended settings for auto top logo/bottom logo printing		✓

NOTE

- For information about the TM-T82X-II Utility, see the TM-T82X-II Utility User's Manual.
- For information about how to use the Software Setting Mode, see "[Software Setting Mode](#)" on page 37.

Overview of Each Function

Interface Settings

Serial Baud Rate

- 2400 bps
- 4800 bps
- 9600 bps
- 19200 bps
- 38400 bps (initial setting)
- 57600 bps
- 115200 bps

Serial Parity

- None (initial setting)
- Odd
- Even

Serial Handshaking

- DTR/DSR (initial setting)
- XON/XOFF

Serial Data Bits

- 7 bits
- 8 bits (initial setting)

USB Class

- Vendor class
- Printer class (initial setting)

Receive Buffer Capacity

This setting item is not displayed if Interface Selection is set to "Multiple".

- 4 KB (initial setting)
- 128 KB

BUSY Condition

- Receive Buffer Full or Offline (initial setting)
- Receive Buffer Full

Interface Selection

The displayed items vary depending on the interface configuration.

- Com (Serial)
- Built-in USB (USB type-B)
- Ethernet
- Multiple (initial setting)

Interface switch waiting time

Select the number of seconds from 1 to 10 in increments of 1 second, or 60 seconds.

- Serial/USB model initial setting: 1 second
- Ethernet/USB model initial setting: 10 seconds

Main connection interface

The displayed items vary depending on the interface configuration.

- Com (Serial)
- Built-in USB (USB type-B)
- Ethernet
- Auto (An interface that received data first) (initial setting)
- No main connection I/F

NOTE

When using this printer with multiple interfaces, make sure the interface that is always connected to be set as the main connection.

The “Auto” setting allows you to use the first interface you communicate with as the main connection and the other interfaces as secondary connections after you turn on the printer. For the limitations on the main connection and secondary connections, see the table below.

Connection Interface	Connection Priority	ESC/POS Command Restrictions	Retaining of Print Settings When Connection Is Terminated
Main connection	High	No	Retained
Secondary connection	Low	Yes*	Initialized

*: For details, see the ESC/POS Command Reference.

NOTE

For information about the function, see ["Printing Using Multiple Interfaces" on page 20](#).

Print Density

Selectable from -3 to +3 (light to dark)

Initial setting: 0

Depending on the paper type, it is recommended to set the print density for the best print quality.

Print Speed

Selectable from levels 1 to 13 (Slow to Fast)

Initial setting: Level 13

Automatic Reduction of Paper

- No Reduction (initial setting)
- Recommended Setting
- Maximum Reduction

Character Settings

Code Page

Selectable from 43 pages including user defined page

Initial setting: Page0:PC437(USA, Standard Europe)

International Character Set

Selectable from 18 sets

Initial setting: USA

Thai Character Composition

- 3 Pass
- 1 Pass (initial setting)

Column Emulation

- 48 Column mode (initial setting)
- 42 Column mode

MAC Address Confirmation

You can check the printer's MAC address using the following procedures.

- Printing the status sheet
- Label affixed near the connector
- Using a Web browser to confirm (Web Config function)
- A printer self-test

Setting/Checking Modes

As well as print mode, the following modes are also provided for making various printer settings and checking items.

- Self-test mode
- NV graphics information print mode
- Receipt Enhancement information print mode
- Software setting mode
- Restore default values mode
- Interface setup mode (Ethernet/USB model only)
- Hexadecimal dumping mode

To enter the Self-test mode or the Hexadecimal dumping mode, turn the printer on with the special operations as described below.

To enter one of the other modes, first enter the Self-test mode, and then select one mode by operating the Feed button as described below.

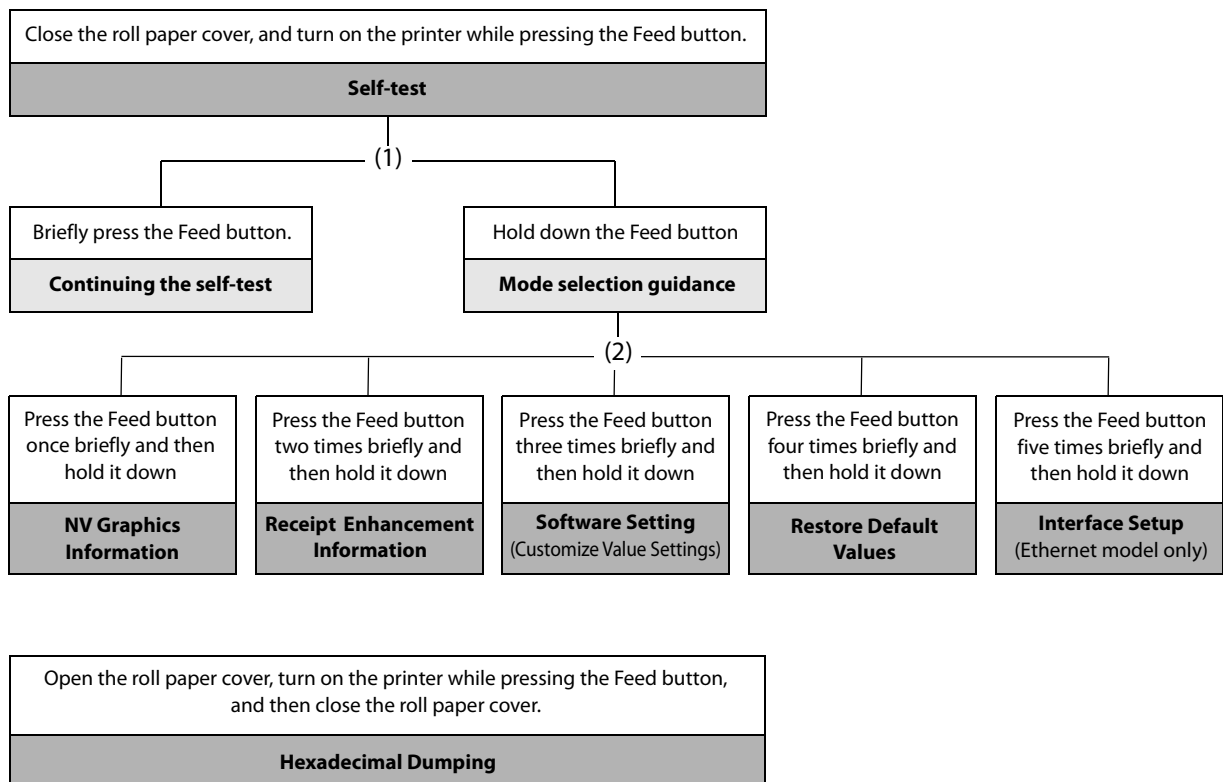

In (1) and (2), the following guidances are printed, the Paper LED flashes, and instructs the user's operations.

1. Continuing self-test guidance

```
Select Modes by pressing Feed Button.  
Continue SELF-TEST: Less than 1 second  
Mode Selection      : 1 second or more
```

2. Mode selection guidance

Mode Selection

Modes

- 0: Exit and Reboot Printer
- 1: NV Graphics Information
- 2: Receipt Enhancement Information
- 3: Customize Value Settings
- 4: Restore Default Values
- 5 or more: None

Select Modes by executing following procedure.

- step 1. Press the Feed button less than 1 second as many times as the selected mode number.
- step 2. Press Feed button for 1 second or more.

Self-test Mode

You can check the following items using the self-test.

- Product name
- Firmware version
- Product serial number
- Interface information
- Resident fonts
- Maintenance counter information (print head running length, number of times of auto-cutting)

Follow the steps below. The self-test can also be executed using ESC/POS Commands.

1 Close the roll paper cover.

**2 While pressing the Feed button, turn on the printer.
(Hold down the Feed button until printing starts.)**

After printing the current print status, a Continuing self-test guidance is printed, and the Power LED flashes.

3 Briefly press the Feed button (less than one second) to continue the self-test.

The printer prints a rolling pattern on the roll paper, using the built-in character set.
After "*** completed ***" is printed, the printer initializes and switches to standard mode.

NV Graphics Information Print Mode

Prints the following NV graphics information registered to the printer.

- Capacity of the NV graphics
- Used capacity of the NV graphics
- Unused capacity of the NV graphics
- Number of NV graphics that are registered
- Key code, number of dots in X direction, number of dots in Y direction to be defined.
- NV graphics data

NOTE

For details on NV graphics, see ["NV Graphics Memory" on page 18](#).

Follow the steps below.

1 After running a self-test, hold down the Feed button for at least one second to enter the Mode selection.

The Mode selection guidance is printed, and the Paper LED flashes.

- 2 After briefly (less than one second) pressing the Feed button once, hold it down for at least one second, to print the NV graphics information.**

After information printing, the Mode selection guidance is printed again.

- 3 To finish, turn off the power, or select “Exit and Reboot Printer”.**

Receipt Enhancement Information Print Mode

You can check the following items using the R/E information mode:

- Auto top logo printing setting
- Auto bottom logo printing setting
- Extended settings for auto top/bottom logo printing

Follow the steps below.

- 1 After running a self-test, hold down the Feed button for at least one second to enter the Mode selection.**

The Mode selection guidance is printed, and the Paper LED flashes.

- 2 After briefly (less than one second) pressing the Feed button twice, hold it down for at least one second, to print the R/E information.**

After information printing, the Mode selection guidance is printed again.

- 3 To finish, turn off the power, or select “Exit and Reboot Printer”.**

Software Setting Mode

You can change the printer settings. For information on available setting items, see ["Software Settings" on page 28](#).

Follow the steps below.

1 After running a self-test, hold down the Feed button for at least one second to enter the Mode selection.

The Mode selection guidance is printed, and the Paper LED flashes.

2 Briefly press the Feed button three times (less than one second), hold it down for at least one second to enter the Software setting mode (Customize Value Settings).

The Software setting mode guidance is printed, and the Paper LED flashes.

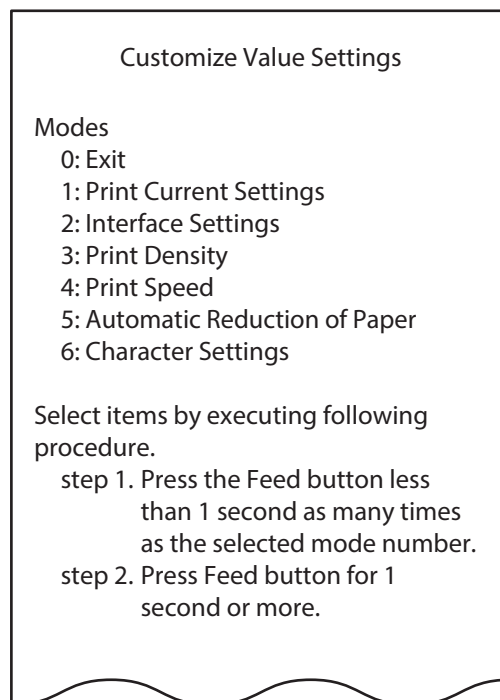

3 After briefly pressing the Feed button (less than one second) for the number of times shown in the print result, hold down the button for more than one second to select the setting items.

The setting selected as the setting item, the current settings and default settings are printed.

Depending on the setting item, you may need to continue selecting the setting item before the settings are printed. For details on setting items, see ["Software Settings" on page 28](#).

CAUTION

When set to a value other than those in the software setting mode, the current settings are not printed.

4 Select a setting by briefly pressing the Feed button (less than one second) for the number of times applicable to the setting, and then hold down the button for more than one second to confirm your selection.

After saving the settings, the Software setting mode guidance is printed, and the Paper LED flashes.

5 To close Software setting mode, turn off the printer, or select “Exit” to return to Mode selection guidance, and then select “Exit and Reboot Printer”.

NOTE

- To select 0 as the item number, hold down the Feed button until printing starts.
- If the button is pressed a number of times that is not displayed by the Setup guidance, the operation is invalid and the same guidance is printed.

Restore Default Values Mode

In Restore default values mode, following values saved on NV Memory will be set back to default settings. When any error occurs, you can use to specify the reason.

Setting Contents	Setting Items	Restore Default Values and Delete Defined Data
Customized value	✓	✓
Memory switches	✓	✓
R/E (Receipt Enhancement) settings	✓	✓
Communication condition of USB interface	✓	✓
Communication condition of serial interface	✓	✓
Communication condition of network interface	✓	✓
NV graphics	-	✓
NV bit image	-	✓
User-defined page	-	✓
User NV Memory	-	✓

Follow the steps below.

1 After running a self-test, hold down the Feed button for at least one second to enter the Mode selection.

The Mode selection guidance is printed, and the Paper LED flashes.

2 Briefly press the Feed button four times (less than one second), hold it down for at least one second to enter the Restore Default Values.

The guidance is printed.

**3 When only restoring the default settings:
Briefly press the Feed button once (less than one second), hold it down for at least one second. (Hold down the Feed button until the restoration complete message is printed.)**

**When restoring default settings and deleting user defined data:
Briefly press the Feed button twice (less than one second), and then hold it down for at least one second. (Hold down the Feed button until the restoration complete message is printed.)**

4 To finish, turn off the power.

NOTE

If you could not confirm that settings were restored to the default values, execute [Restore Default Values Mode] again. If the firmware version is 20.02 ESC/POS or later, the following message is printed when the restoration fails.

```
Failed restoration to Factory Default.
Please retry after restarting printer.
```

Interface Setup Mode (Ethernet/USB model only)

Use this mode to setup the interface and other settings.

Follow the steps below.

- 1 After running a self-test, hold down the Feed button for at least one second to enter the Mode selection.**
The Mode selection guidance is printed, and the Paper LED flashes.
- 2 Briefly press the Feed button five times (less than one second), hold it down for at least one second to enter the Interface Setup mode.**
The guidance is printed.
- 3 After briefly pressing the Feed button (less than one second) for the number of times shown in the print result, hold down the button for more than one second to select the setting items.**

Initialize

Select [Ethernet Setup] and select [Initialize] to initialize the network setting parameter. The printer is reset and restarted.

NOTE

If you could not confirm that the interface settings were initialized, execute [Initialize] again. If the firmware version is 20.02 ESC/POS or later, the following message is printed when the initialization fails.

```
Failed restoration to Factory Default.
Please retry after restarting printer.
```

Hexadecimal Dumping Mode

In the hexadecimal dumping mode, the printer prints the data transmitted from a host computer in hexadecimal numbers and their corresponding characters. It enables you to check if data is transmitted to the printer correctly.

NOTE

- If there is no character corresponding to print data, "." is printed.
- If you press the Feed button when there is less than one line of print data, one line is printed.
- During hexadecimal dumping mode, applications that check the printer status may not operate correctly. The printer only returns the status for the "Real-time transmission status" command.

Follow the steps below. Hexadecimal Dumping Mode can also be executed using ESC/POS Commands.

- 1 Open the roll paper cover.**
- 2 While pressing the Feed button, turn on the printer. (Hold down the Feed button until the Error LED turns on.)**
- 3 Close the roll paper cover.**
The printer starts printing data received from then on in hexadecimal numbers and their corresponding ASCII characters.

Example of printing in hexadecimal dumping mode:

```
Hexadecimal Dump
To terminate hexadecimal dump,
press FEED button three times.

1B 21 00 1B 26 02 40 40 1B 69 . ! . . & . @ @ . i
1B 25 01 1B 63 34 00 1B 30 31 . % . . c 4 . . 0 1
41 42 43 44 45 46 47 48 49 4A A B C D E F G H I J

*** completed ***
```

- 4 To close hexadecimal dumping mode, turn off the printer after printing is complete, or press the Feed button for three times.**

Printing a Status Sheet (For Ethernet/USB Model Only)

Follow the steps below to check the Ethernet interface settings.

NOTE

When the power LED is flashing, wait until it remains lit to start printing.

Using the Status Sheet Button

- 1 Check that the printer is turned on.**
Make sure the roll paper cover is closed.
- 2 Hold down the status sheet button for at least three seconds.**
A guidance that starts with "Next Action" will be printed.
- 3 Press the Feed button briefly (less than one second) the number of times equal to the number indicated to the left of the status sheet you want to print, then hold down the button for at least one second.**
Printing of a status sheet will start. The printer will return to normal mode after printing is finished.

Using the Feed button

- 1 Check that the printer is turned on.**
- 2 Open the roll paper cover.**
- 3 Hold down the Feed button (for 1 seconds or longer).**
- 4 Close the roll paper cover.**
A guidance that starts with "Next Action" will be printed.
- 5 Press the Feed button briefly (less than one second) the number of times equal to the number indicated to the left of the status sheet you want to print, then hold down the button for at least one second.**
Printing of a status sheet will start. The printer will return to normal mode after printing is finished.

Status sheet printout example

```
HHH Network Status Sheet HHH



<General Info>
MAC Address      XX:XX:XX:XX:XX:XX
Firmware         XX.XX
                 (XXXXXXXXXXXXXXXX)
Printer Model    TM-T82X-II
Device Name      XXXXXXXXXXXX

<Ethernet>
Network Status   Auto(100BASE-TX, Full
                 Duplex)
Port Type        Auto
IEEE802.3az      Enable

<Ethernet HW Info>
Auto-Nego complete 1
LP Auto-Nego      1
:
:

<TCP/IP IPv4>
IPv4              Enable
Obtain IP Address Auto(DHCP)
IP Address        192.168.192.168
Subnet Mask       255.255.255.0
Default Gateway   None
APIPA             Disable
:
:
```

Resetting the Interface Settings

Follow the steps below to reset the interface settings.

NOTE

- You can return the interface settings to their defaults from the Interface Setup mode. For details on the Interface Setup mode, see "[Interface Setup Mode \(Ethernet/USB model only\)](#)" on page 40.
- Only network settings are returned to their defaults.

1 Turn off the printer and close the roll paper cover.

2 Hold down the status sheet button while turning on the printer.

A message is printed indicating that resetting is being performed, and the printer restarts.

CAUTION

Hold down the status sheet button until the initialization execution message is printed.

NOTE

If you could not confirm that the interface settings were initialized, execute [Initialize] again. If the firmware version is 20.02 ESC/POS or later, the following message is printed when the initialization fails.

Failed restoration to Factory Default.
Please retry after restarting printer.

Web Config (For Ethernet/USB model only)

Web Config is a printer's built-in web page that allows you to check and change printer settings on your browser.

To use Web Config, you need to set your computer's IP address to the same segment as the printer.

How to Start Web Config

- 1 **Start your web browser on a computer or smart device on the network and enter the IP address of the printer in the address field.**

Example: `https://192.168.192.168`

- 2 **After Web Config starts, select the menu you wish to configure.**

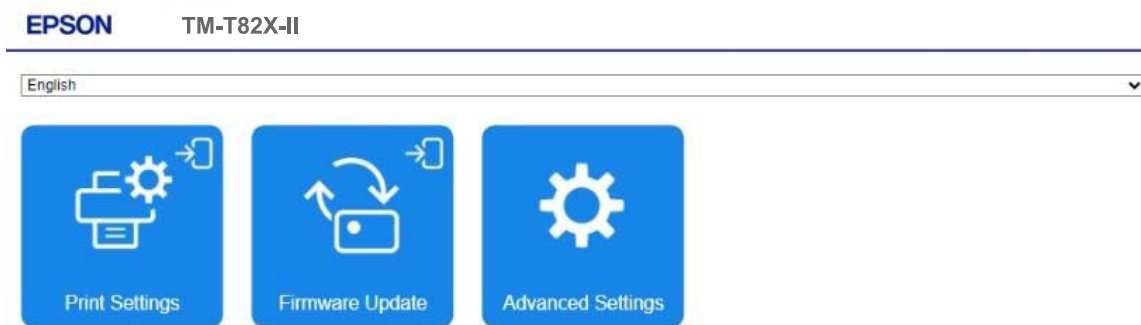

- 3 **When the authentication screen appears, enter your password and log in.**

The default password is the serial number of the printer. You can find the serial number by running the self-test or on the nameplate attached to the printer.

NOTE

Enable JavaScript in your browser. Because a self-signed certificate owned by the printer is used when accessing HTTPS, a warning will appear in the browser when Web Config is started.

What can be Configured in Web Config

For information on what can be configured in Web Config, refer to the Web Config Reference Guide. The Web Config Reference Guide can be obtained from the URL listed in "[Download](#)" on page 51.

Application Development Information

This chapter describes how to control the printer and gives information useful for printer application development.

Controlling the Printer

The printer supports the ESC/POS commands.

Users can control the printer by using the aforementioned command, or the following development kits or drivers.

- Epson ePOS SDK
- OPOS ADK
- OPOS ADK for .NET
- JavaPOS ADK
- EPSON Advanced Printer Driver (APD)
- EPSON TM Virtual Port Driver
- Mac Printer Driver
- TM Series Printer Driver for Linux

ESC/POS

ESC/POS is the Epson original printer command system for POS printers and customer display.

With ESC/POS commands, you can directly control all the printer functions, but detailed knowledge of printer specifications or combination of commands is required, compared to using drivers and applications.

For detailed information about ESC/POS commands, see the ESC/POS Command Reference for TM Printers that can be accessed from the following URL:

https://support.epson.net/publist/reference_en/

Controlling the Cash Drawer

A pulse output is sent to drawer kick connector pin 2 or pin 5, and you can open the drawer.

You can also check the open/close status of the drawer by checking the signal level of the drawer kick connector pin 3.

These controls are executed by a driver or by commands.

ESC/POS Commands

Prepare the output command for the specified pulse and the status transmission command.

For details, see the ESC/POS Command Reference.

For Windows Printer Drivers (APD)

You can set so that the drawer opens at the start of printing. For details, see the manual for drivers.

For details on control, see the manual for Status API of the driver.

OPOS (OCX Driver)

Register a cash drawer using the SetupPOS Utility, and control using the OpenDrawer method or the DirectIO function.

For details, see the “EPSON OPOS ADK MANUAL APPLICATION DEVELOPMENT GUIDE Cash Drawer” and the “UnifiedPOS Specification”.

OPOS for .NET

Register a cash drawer using the SetupPOS Utility, and control using the OpenDrawer method or the DirectIO function.

For details, see the “EPSON OPOS ADK for .NET MANUAL Application Development Guide Cash Drawer (EPSON Standard)” and the “UnifiedPOS Specification”.

Epson ePOS SDK

The output command for the drawer kick pulse and the status transmission command are provided in each SDK library. For details, see the user's manuals provided with each SDK.

NOTE

- Whether or not pin 2 or pin 5 operates the drawer kick connector depends on the connected cash drawer.
- You can acquire documents regarding the UnifiedPOS from the following link.
<https://www.omg.org/spec/UPOS>

Controlling the Optional External Buzzer

You can set the optional external buzzer to buzz when an error occurs and when an automatic cut off occurs.

The buzzer can be buzzed at any time using a driver or a command.

You can also set the timing and the beep pattern for the buzzer.

ESC/POS Commands

Use the buzzer control command or the output command for the specified pulse.

For details, see the ESC/POS Command Reference.

For Windows Printer Drivers (APD)

Use the DirectIO function or the API for opening the drawer. For details, see the manual for Status API of the drivers.

OPOS (OCX Driver)

Register a POS printer using the SetupPOS Utility and control using the DirectIO function.

For details, see the “EPSON OPOS ADK MANUAL APPLICATION DEVELOPMENT GUIDE POSPrinter (TM Series)”.

OPOS for .NET

Register a POS printer using the SetupPOS Utility and control using the DirectIO function.

For details, see the “EPSON OPOS ADK for .NET MANUAL Application Development Guide POS Printer”.

Epson ePOS SDK

The command for the buzzer function is provided in each SDK library. For details, see the user's manuals provided with each SDK.

NOTE

For details on setting the optional external buzzer, see ["Connecting the Optional External Buzzer" on page 27](#).

Software

The following software is provided for application development.

Development Kits

Software	Description
Epson ePOS SDK for Android for iOS	This is a development kit for controlling TM printers from native applications of smart devices. This includes libraries, manuals, and sample programs.
EPSON OPOS ADK	This OCX driver can control POS peripherals using OLE technology.* Because controlling POS peripherals with original commands is not required on the application side, efficient system development is possible.
EPSON OPOS ADK for .NET	The OPOS ADK for .NET is a POS industry standard printer driver compatible with Microsoft POS for .NET. It allows you to develop applications that are compatible with the UPOS (Unified POS) specification. When developing applications, use a separate development environment such as Microsoft Visual Studio .NET.
EPSON JavaPOS ADK (Windows/Linux)	JavaPOS is the standard specification which defines an architecture and device interface (API) to access various POS devices from a Java based system. Using JavaPOS standard API allows control with Java based applications of functions inherent to each device. A flexible design with Java language and JavaPOS enables many different types of computer systems, such as stand alone or network configuration, to use a same application. You can use JavaPOS to build applications and drivers independently of platforms. This allows flexible configurations using thin clients to meet the system requirements.

* OLE technology developed by Microsoft divides software into part blocks. The OPOS driver is presupposed to be used with a development environment, such as Visual Basic, unlike ordinary Windows printer drivers. It is not a driver to be used for printing from commercial applications.

You can acquire documents regarding the UnifiedPOS from the following link.

<https://www.omg.org/spec/UPOS>

Drivers

Software	Description	Operating environment
EPSON Advanced Printer Driver (APD)	In addition to ordinary Windows printer driver functions, this driver has controls specific to POS. The Status API (Epson original DLL) that monitors printer status and sends ESC/POS commands is also attached to this driver.	Windows
EPSON TM Virtual Port Driver	This is a serial/parallel-USB/LAN conversion driver to make an Epson TM/BA/EU printer connected via USB or LAN accessible from a POS application through a virtual serial or parallel port. It allows you to directly control devices connected via USB or LAN with ESC/POS commands without making changes in the POS application that controls devices connected via a serial or parallel interface.	Windows
TM Series Printer Driver for Mac	This driver allows you to control the printer using Common UNIX Printing System (CUPS) on macOS. This is a full raster printer driver. It is able to print images, text, and vector graphics etc., that an application displays. With this driver many printer controls are possible, such as paper cut timing control, cash drawer control, printing speed control, blank line skip, and upside-down printing. It also provides API and dialogues for print setting, sample applications, and logo setting utility.	macOS
TM Series Printer Driver for Linux	This driver allows you to control the printer using Common UNIX Printing System (CUPS) on GNU/Linux. This is a full raster printer driver. It is able to print images, text, and vector graphics etc., that an application displays.	GNU/Linux

Utilities

Software	Description	Operating environment
TM-T82X-II Utility	A utility for checking and changing various printer settings. Use this utility to: <ul style="list-style-type: none"> • Check the current settings • Test operation • Store logos • Set paper reduction • Set printing control • Set communication interfaces • Set the network • Save/restore settings 	Windows
Epson Deployment Tool	Use to make network and printer settings simultaneously. Allows you to make settings efficiently at the time of introducing TM printers for the first time, or when configuring multiple TM printers at the same time.	Windows
Epson Monitoring Tool	Use to check a list of status for the Epson printers connected to the network. You can also update certificates for multiple printers in a batch.	Windows

Others

Manual	Description
Web Config Reference Guide	Describes items that can be configured in Web Config.

Download

You can obtain software and manuals from one of the following URLs.

For customers in North America, go to the following web site:

<https://www.epson.com/support/>

For customers in other countries and regions, go to the following web site:

<https://epson.sn>

Notes on Printing Barcodes and Two-dimensional Symbols

- The user must set the quiet zone, depending on the barcode standards.
- When printing PDF417 (two-dimensional symbols), the following are recommended:
 - Module height: 3 to 5 times the module width
 - Vertical size of the symbol: approximately 5 mm {0.20"} or more
- The recognition rate of ladder barcodes and two-dimensional symbols may vary depending on widths of the modules, print density, environmental temperature, type of paper, and characteristics of the reader. Therefore, the user must check the recognition rate before setting the use conditions so that the restrictions of the reader are satisfied.
- Reading quality of barcodes and two-dimensional symbols in graphics multiple tone printing is not guaranteed.
- When printing ladder barcodes or two-dimensional symbols with graphics printing, use one of the following settings.
 - *Select the appropriate print control mode. (Recommended)
 - *Set the print speed to Level 5.

The print control mode and the print speed can be selected using the ESC/POS command.

Handling

This chapter describes basic handling of the printer.

Installing and Replacing Roll Paper



- Do not open the roll paper cover during printing. The printer may be damaged.
- Do not touch the manual cutter with your hands when installing or replacing the roll paper. Otherwise, you may be injured because the manual cutter blade is sharp.

CAUTION

- Use roll paper that meets the printer specification. For details about paper specification, see ["Paper Specifications" on page 62](#).
- Paper must not be pasted to the roll paper spool.

- 1** Put your finger under the knob and lift open the roller paper cover.

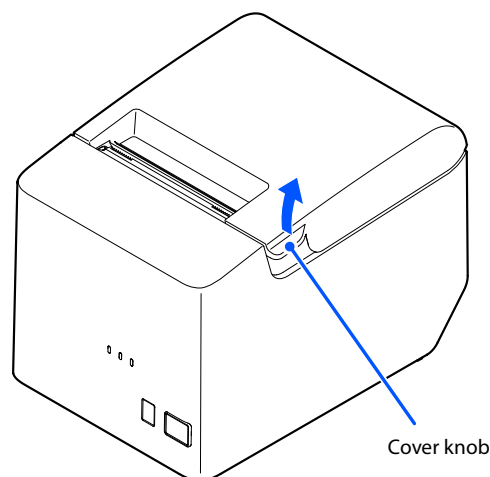

- 2** Remove the used roll paper core, if any.

3 Install the roll paper in the correct direction.

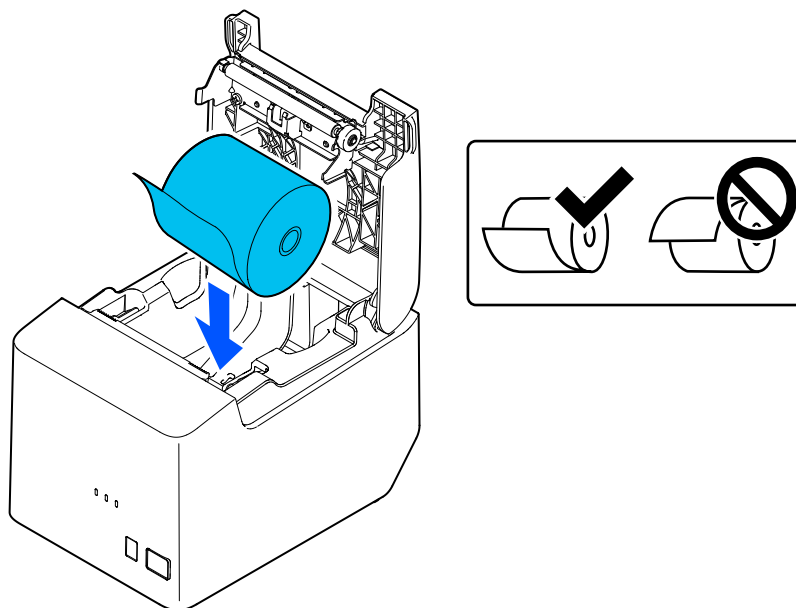

4 Pull out some roll paper, and close the roll paper cover.

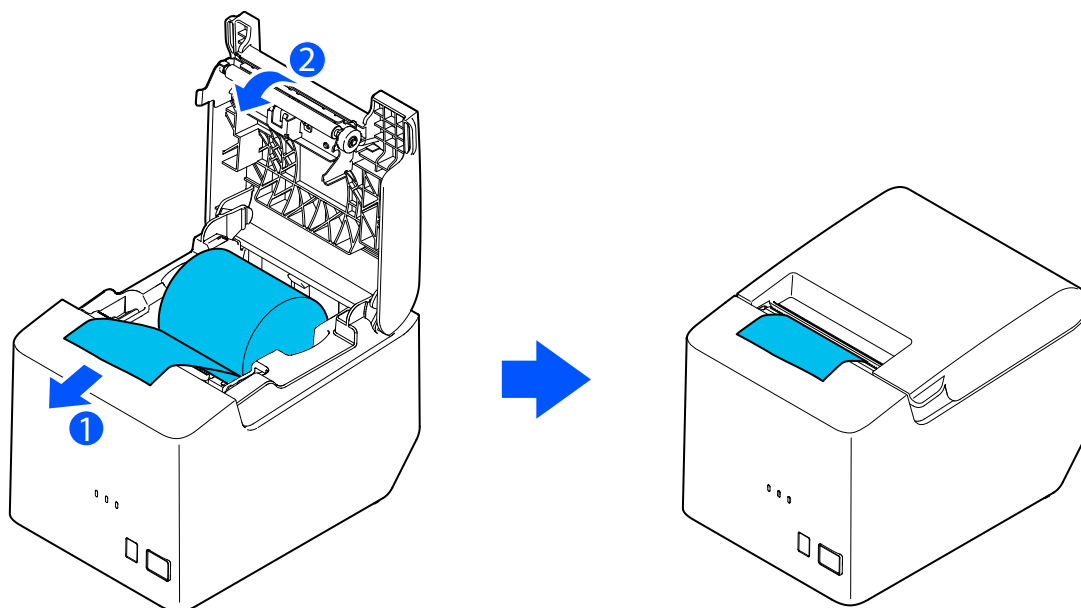

Removing Jammed Paper

When a paper jam occurs, never pull out the paper forcibly. Open the roll paper cover, and then remove the jammed paper.



Do not touch the thermal head. (See "[Cleaning the Thermal Head/Platen Roller](#)" on page 56.)
After printing, the thermal head and its surroundings can be very hot.

When the Roll Paper Cover Cannot be Opened

If the roll paper cover cannot be opened after powering on the printer, the printer may be defective. Contact qualified service personnel.

Cleaning the Printer

Cleaning the Printer Case

Be sure to turn off the printer, and wipe the dirt off the printer case with a dry cloth or a damp cloth. Be sure to unplug the AC cable while cleaning.



Never clean the product with alcohol, benzine, thinner, or other such solvents. Doing so may damage or break the parts made of plastic and rubber.

Cleaning the Thermal Head/Platen Roller

Epson recommends cleaning the thermal head periodically (generally every 3 months) to maintain receipt print quality. Depending on the roll paper used, paper dust may stick to the platen roller and cause an irregular paper feed. To remove the paper dust, clean the platen roller with a cotton swab moistened with water. Turn on the printer power only after the water has completely dried.

Turn off the printer and open the roll paper cover. Clean the thermal elements of the thermal head with a cotton swab moistened with an alcohol solvent (ethanol or IPA).



- After printing, the thermal head can be very hot. Do not touch it and let it cool before you clean it.
- Do not damage the thermal head by touching it with your fingers or any hard object.

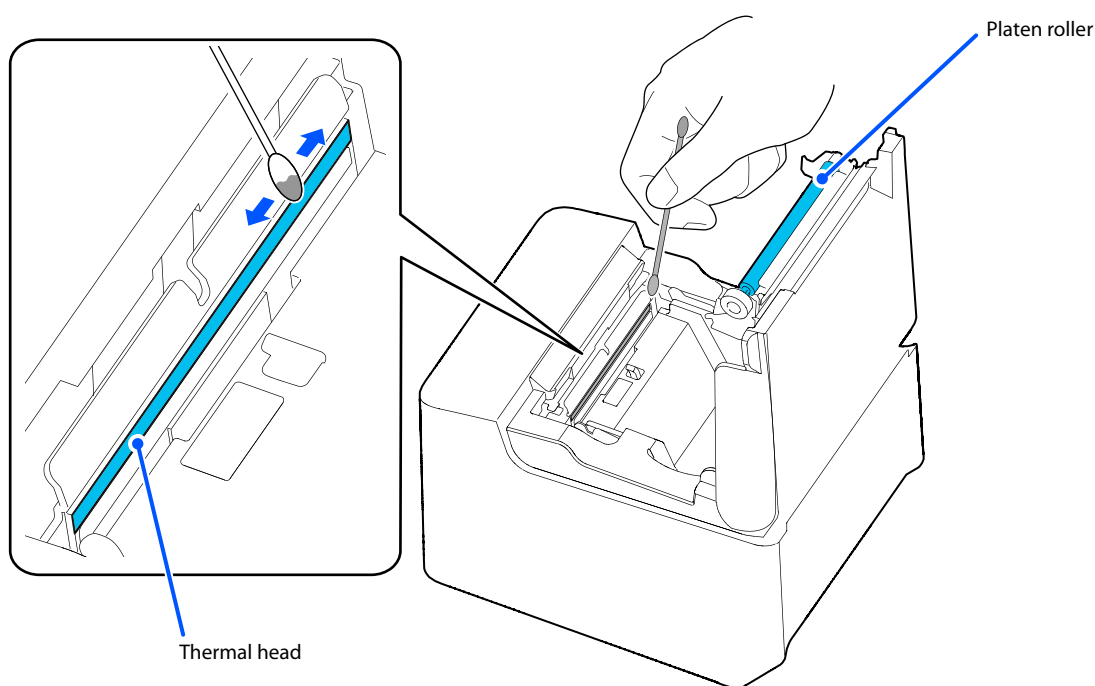

Preparing for Transport

Follow the steps below to transport the printer.

- 1** Turn off the printer.
- 2** Ensure that the Power LED has turned off.
- 3** Disconnect the AC cable.
- 4** Remove the roll paper.
- 5** Pack the printer upright.

Checking the Nameplate

The nameplate is affixed to the side of the printer.

It shows the product name, model number, and serial number.

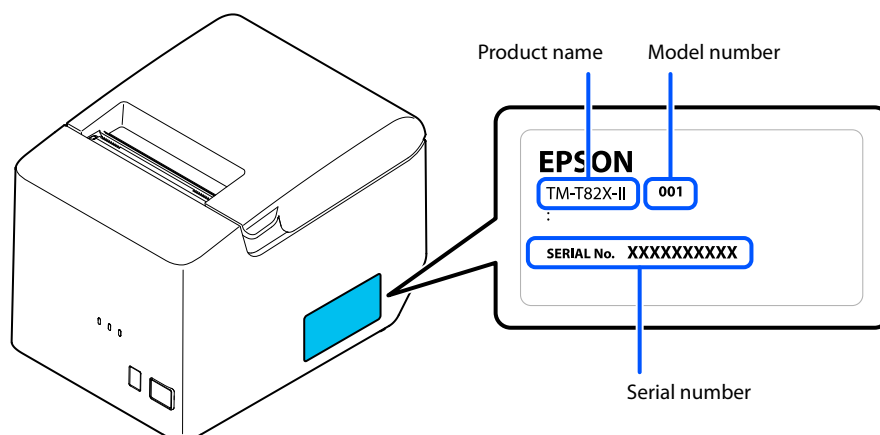

Appendix

Product Specifications

Printing method		Thermal line printing
Paper feed speed		Approx. 200 mm/s {approx. 7.88 in./s} (continuous paper feeding with the Feed button)
Cutting Method		Partial cut (cutting with one point at center left uncut)
Interface	Serial/USB model	Serial: RS-232 USB: USB 2.0 Full-speed (12 Mbps)
	Ethernet/USB model	Ethernet: 10BASE-T/100BASE-TX USB: USB 2.0 Full-speed (12 Mbps)
Buffers	Receive buffer	4 KB or 128 KB
	Downloaded buffer	Approx. 12 KB (both for user-defined characters and downloaded images)
	NV graphics data	256 KB
	Downloaded graphics data	208 KB
Barcode/two-dimensional symbol/ composite symbol printing		UPC-A, UPC-E, JAN8 (EAN8), JAN13 (EAN13), CODE39, ITF, CODABAR (NW-7), CODE93, CODE128, CODE128 auto, GS1-128, GS1 DataBar Omnidirectional, GS1 DataBar Truncated, GS1 DataBar Stacked, GS1 DataBar Stacked Omnidirectional, GS1 DataBar Limited, GS1 DataBar Expanded, GS1 DataBar Expanded Stacked, PDF417, QR Code, MaxiCode, Composite Symbology
Drawer kick connector drive function		2 drives
Power supply		Rated voltage: AC100 to 240 V / 50 to 60Hz Rated current: 1.0 A
AC power consumption (100 to 230 V / 50 to 60 Hz) ^{*1}	Operating	Approx. 31.3 W
	Standby	Approx. 0.96 W
	Power off	Approx. 0.03 W
Life ^{*2}	Mechanism	15 million lines
	Thermal head	100 km
	Autocutter	1,500,000 cuts
MTBF ^{*3}		360,000 hours
MCBF ^{*4}		60,000,000 lines
Temperature/humidity		Operating: 5 to 45°C {41 to 113°F}, 10 to 90% RH Storage: -10 to 50°C {14 to 122°F}, 10 to 90% RH

Overall dimensions (H × W × D)	140 × 149 × 192 mm {5.51 × 5.87 × 7.56 in.}
Mass	Approx. 1.5 kg {3.31 lb} (roll paper excluded)

*1: According to our operation conditions

*2: Indicates the point at which the wear-out failure period starts.

*3: Indicates the mean time between failures during the random failure period.

*4: Indicates the overall mean time between failures, including wear-out and random failures, before the life is reached.

Printing Specifications

			80 mm model	58 mm model
Printing method			Thermal line printing	
Paper feed direction			Unidirectional with friction feed	
Dot density			203 × 203 dpi	
Printing width	48 column mode (Standard mode)		72.0 mm {2.83 in.}, 576 dots	52.5 mm {2.07 in.}, 420 dots
	42 column mode		68.3 mm {2.69 in.}, 546 dots	47.3 mm {1.86 in.}, 378 dots
Characters per line	48 column mode (Standard mode)	Font A	48	35
		Font B	64	46
		Kanji font	24	17
		Special Font A	48	35
		Special Font B	64	46
	42 column mode	Font A	42	42
		Font B	60	31
		Kanji font	21	15
		Special Font A	42	42
		Special Font B	60	31
Character spacing	48 column mode (Standard mode)	Font A	0.25 mm {0.0098 in.}, 2 dots	
		Font B	0.25 mm {0.0098 in.}, 2 dots	
		Kanji font	0.00 mm, 0 dot	
		Special Font A	0.25 mm {0.0098 in.}, 2 dots	
		Special Font B	0.25 mm {0.0098 in.}, 2 dots	
	42 column mode	Font A	0.38 mm {0.015 in.}, 3 dots	0.25 mm {0.0098 in.}, 2 dots
		Font B	0.25 mm {0.0098 in.}, 2 dots	0.25 mm {0.0098 in.}, 2 dots
		Kanji font	0.25 mm {0.0098 in.}, 2 dots	0.00 mm, 0 dot
		Special Font A	0.38 mm {0.015 in.}, 3 dots	0.25 mm {0.0098 in.}, 2 dots
		Special Font B	0.25 mm {0.0098 in.}, 2 dots	0.25 mm {0.0098 in.}, 2 dots
Line spacing			3.75 mm {0.15 in.} (default setting, programmable by command)	
Maximum print speed			250 mm/s {9.84 in./s}* [†]	

dpi: dots per inch

*: The maximum is 100 mm/s {3.94 in./s} when printing ladder barcodes or two-dimensional symbols.

NOTE

- Printing speed may be slower, depending on such items as the data transmission speed.
- Special font A/B is only equipped to the South Asia model.

Character Specifications

			80 mm model	58 mm model
Number of characters			Single-byte code characters <ul style="list-style-type: none"> • Alphanumeric characters: 95 characters • Extended graphics: 128 characters × 43 pages (including user-defined page) • International characters: 18 sets Multi-byte code characters <ul style="list-style-type: none"> • Simplified Chinese: GB18030-2022 28,806 characters (Lv.2) (for Simplified Chinese characters model) • Traditional Chinese: Big5 13,535 characters (for Traditional Chinese characters model) 	
Character structure (W × H dots)	48 column mode (Standard mode)	Font A	12 × 24 (Right-side dot space: 2)	
		Font B	9 × 17 (Right-side dot space: 2)	
		Kanji font	24 × 24 (Right-side dot space: 0)	
		Special Font A	12 × 24 (Right-side dot space: 2)	
		Special Font B	9 × 24 (Right-side dot space: 2)	
	42 column mode	Font A	13 × 24 (Right-side dot space: 3)	9 × 17 (Right-side dot space: 2)
		Font B	9 × 17 (Right-side dot space: 2)	12 × 24 (Right-side dot space: 2)
		Kanji font	26 × 24 (Right-side dot space: 2)	24 × 24 (Right-side dot space: 0)
		Special Font A	13 × 24 (Right-side dot space: 3)	9 × 24 (Right-side dot space: 2)
		Special Font B	9 × 24 (Right-side dot space: 2)	12 × 24 (Right-side dot space: 2)
Character size *	48 column mode (Standard mode)	Font A	1.25 × 3.00 mm {0.05 × 0.12 in.}	
		Font B	0.88 × 2.13 mm {0.03 × 0.08 in.}	
		Kanji font	3.00 × 3.00 mm {0.12 × 0.12 in.}	
		Special Font A	1.25 × 3.00 mm {0.05 × 0.12 in.}	
		Special Font B	0.88 × 3.00 mm {0.03 × 0.12 in.}	
	42 column mode	Font A	1.25 × 3.00 mm {0.05 × 0.12 in.}	0.88 × 2.13 mm {0.03 × 0.08 in.}
		Font B	0.88 × 2.13 mm {0.03 × 0.08 in.}	1.25 × 3.00 mm {0.05 × 0.12 in.}
		Kanji font	3.00 × 3.00 mm {0.12 × 0.12 in.}	
		Special Font A	1.25 × 3.00 mm {0.05 × 0.12 in.}	0.88 × 3.00 mm {0.03 × 0.12 in.}
		Special Font B	0.88 × 3.00 mm {0.03 × 0.12 in.}	1.25 × 3.00 mm {0.05 × 0.12 in.}

Note:

*: Space between characters is not included. Characters can be scaled up to 64 times as large as the standard size.

Paper Specifications

		80 mm model	58 mm model
Paper types		Specified thermal paper	
Form		Roll paper	
Size	Roll paper diameter	Max.: 83 mm {3.27 in.}	
	Roll paper spool outer diameter	Min.: 18 mm {0.71 in.}	
	Roll width when taken up	80+0.5/-1.0 mm {3.15+0.02/-0.04 in.}	58+0.5/-1.0 mm {2.28+0.02/-0.04 in.}
	Paper width	79.5±0.5 mm {3.13 ±0.02 in.}	57.5±0.5 mm {2.26±0.02 in.}
	Paper thickness	Maximum of 75 µm, minimum of 53 µm	
Specified original paper type		TF50KS-EY (Nippon Paper Industries Co., Ltd.) PD160R (Oji Imaging Media Co., Ltd.) KT48FA (Koehler Paper Group) Epson Certified Media List for Thermal Receipt Printers  https://support.epson.net/publist/bsredirect.php?code=M001035	

CAUTION

- Paper must not be pasted to the roll paper spool.
- For the best print quality for each paper type, it is recommended to set the print density. (See "[Software Settings](#)" on page 28.)
- Use of thermal paper with a pre-printed recording surface should be avoided. Using it can cause the thermal head to stick to the thermal paper surface during printing, and cause printing failure and other problems. The pre-printing also can result in reduced print density. Using thermal paper with a pre-printed recording surface, pre-printing should be done in accordance with the conditions (ink type, printing and other conditions) recommended by the paper manufacturer, and the thermal paper should be checked to ensure that there is no faulty printing, loss of print density, or other problems.

Printable Area

80 mm model

The maximum printable area of paper with a width of 79.5 ± 0.5 mm { 3.13 ± 0.02 in.} is 72.0 ± 0.2 mm { 2.83 ± 0.008 in.} (576 dots) and the approximate space is 3.75 mm {0.15 in.} on the left side and 3.75 mm {0.15 in.} on the right side.

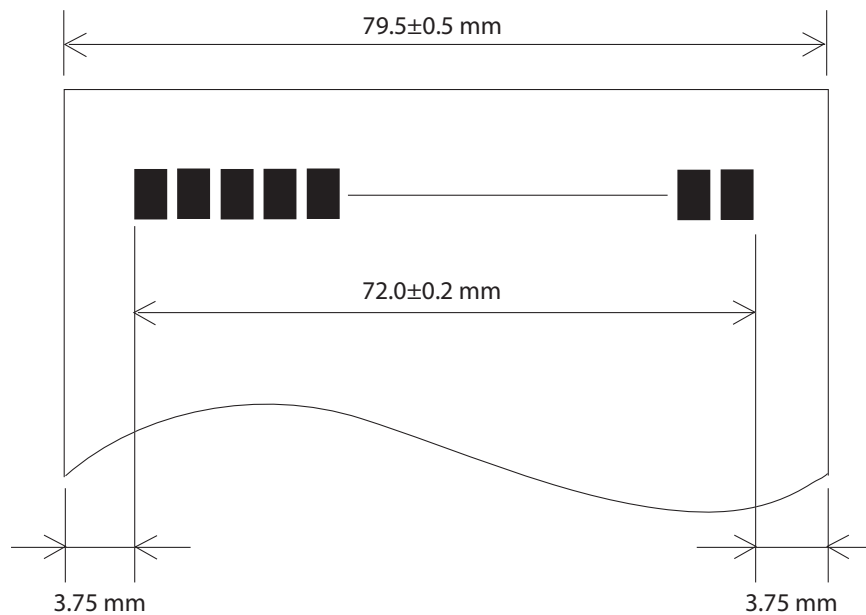

58 mm model

The maximum printable area of paper with a width of 57.5 ± 0.5 mm { 2.26 ± 0.02 in.} is 52.5 ± 0.2 mm { 2.07 ± 0.008 in.} (420 dots), and the approximate space is 2.5 mm {0.10 in.} on the left side and 2.5 mm {0.10 in.} on the right side.

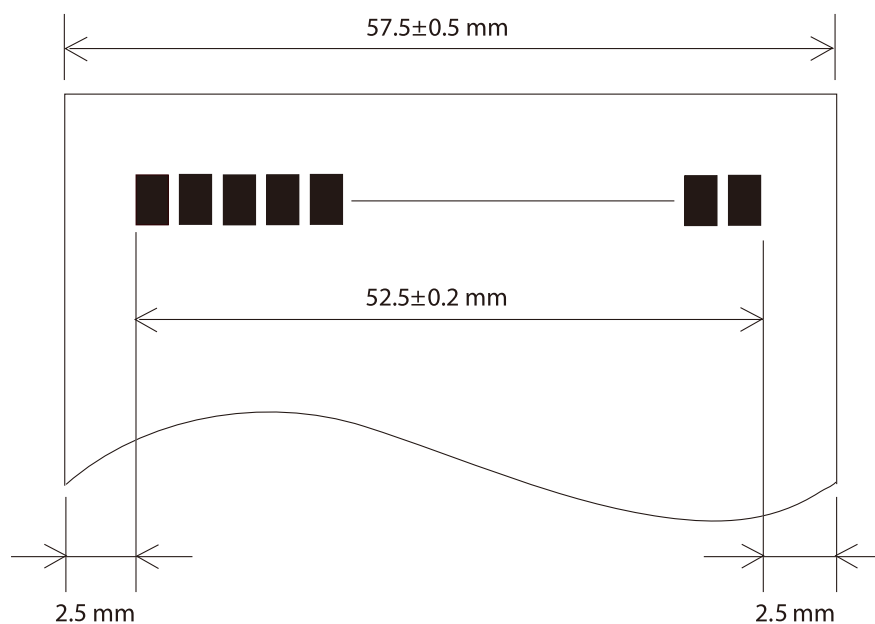

Printing and Cutting Positions

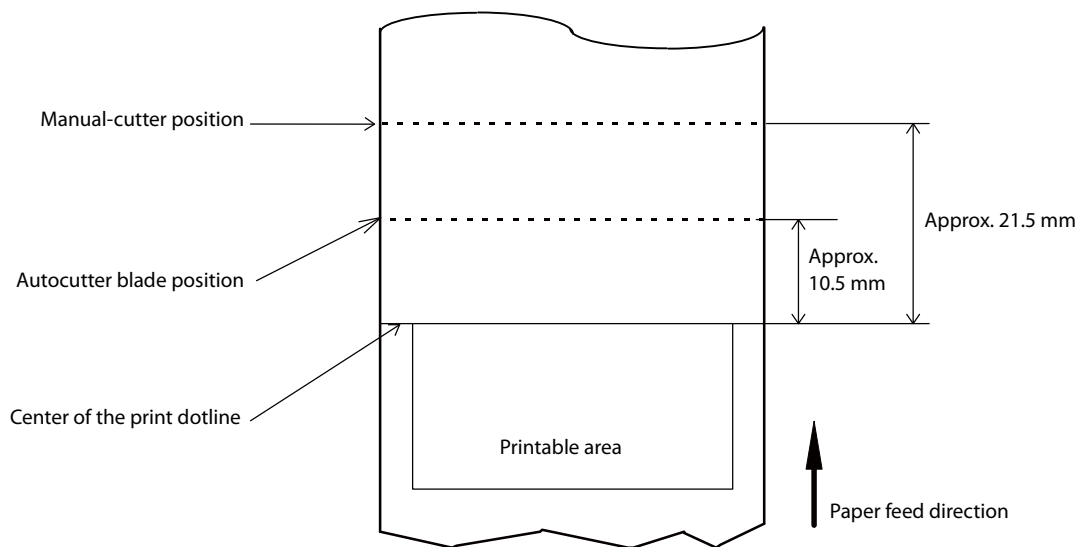

CAUTION

- The values above may vary slightly as a result of paper slack or variations in the paper. Take this into account when setting the cutting position of the autocutter.
- When removing cut paper, the remaining roll paper is pulled at the uncut section and the pitch of the next print may be reduced. When printing after cutting paper for prints with no pitch reduction, feed the paper about 1 mm {16/406 in.} before printing.
- When leaving paper loaded for an extended period of time, make sure you feed about 40 mm of paper. This can prevent paper from wrinkling and causing prints to be too light.

Electrical Characteristics

Rated voltage/frequency	AC100 to 240 V / 50 to 60 Hz
Rated current	1.0 A

CAUTION

If printing is continuously performed with a high print ratio, the overcurrent protection may be activated and result in uneven print density or a low voltage error. Therefore, the printing length must not exceed the following values when printing with high print ratio.

Print ratio: Number of dots being energized per one dot line / Total number of dots per one dot line
 The total number of dots per one dot line is 420 dots for the 58 mm model, and 576 dots for the 80 mm model.

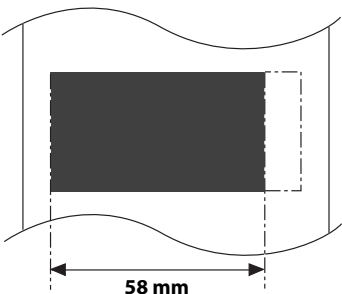
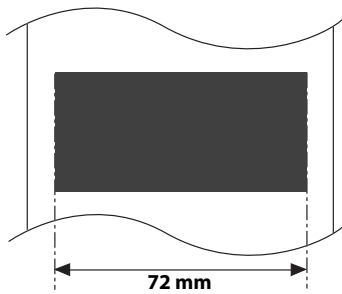
Print ratio	80%	100%
Print example		
Print length	30 mm	20 mm

Environmental Conditions

Temperature/ Humidity	Operating	5 to 45°C {41 to 113°F}, 10 to 90% RH (See the operating environment range below.)
	Storage	-10 to 50°C {14 to 122°F}, 10 to 90% RH (except for paper)
		<p>The graph plots Relative humidity [%RH] on the vertical axis (0 to 90) against Ambient temperature [°C] on the horizontal axis (0 to 50). A shaded region represents the 'Operating environment range'. The range is defined by a constant 10% RH from 5°C to 34°C, a peak of 90% RH at 34°C, a decrease to 65% RH at 40°C, a further decrease to 50% RH at 45°C, and a return to 10% RH from 45°C to 50°C.</p>
Vibration resistance	When packed	<p>Frequency: 5 to 55 Hz</p> <p>Acceleration: Approximately 19.6 m/s² {2 G}</p> <p>Sweep: 10 minutes (half cycle)</p> <p>Time: 1 hour</p> <p>Orientation: x, y, and z</p> <p>There is no external or internal visible damage and the unit operates normally after being subjected to vibration.</p>
Impact resistance	When packed	<p>Packing: Epson standard package specifications</p> <p>Height: 60 cm {23.62 in.}</p> <p>Orientation: 1 corner, 3 edges, and 6 surfaces</p> <p>There is no external or internal visible damage and the unit operates normally after being dropped.</p>
	When unpacked	<p>Height: 5 cm {1.97 in.}</p> <p>Orientation: Lift one edge and release it (for all 4 edges)</p> <p>There is no external or internal visible damage and the unit operates normally after being dropped while not operating.</p>
Acoustic noise (operating)		<p>Approx. 55 dB (bystander position)</p> <p>Note: The values above are measured in the Epson evaluation condition.</p> <p>Acoustic noise differs depending on the paper used, printing contents, and the setting values, such as print speed or print density.</p>

External Dimensions and Mass

- Height: Approx. 140 mm {5.51 in.}
- Width: Approx. 149 mm {5.87 in.}
- Depth: Approx. 192 mm {7.56 in.}
- Mass: Approx. 1.5 kg {3.31 lb} (excluding roll paper)

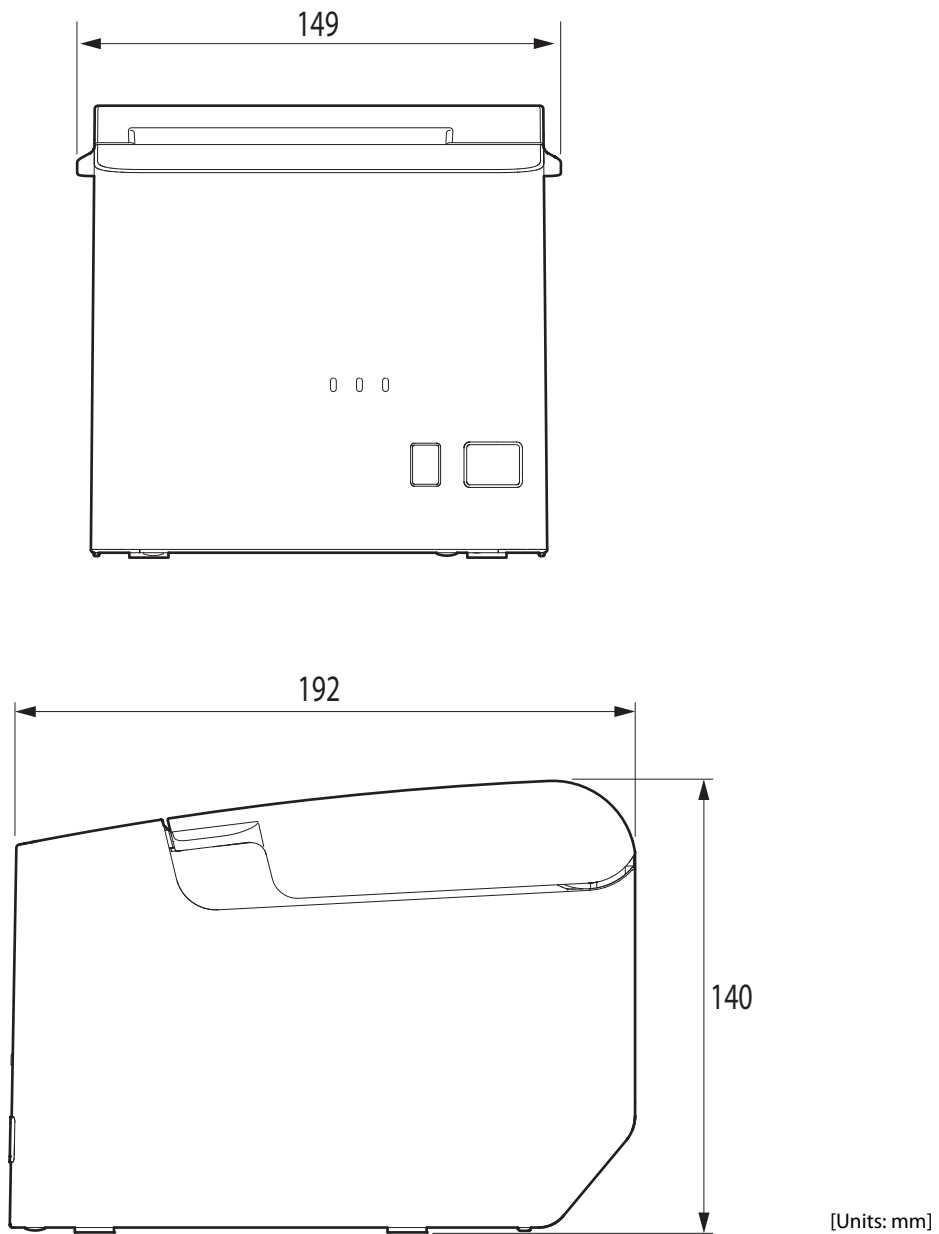

Specifications of Interfaces and Connectors

USB Interface

CAUTION

- Use a USB cable that complies with the USB 2.0 standard. Using a non-compliant cable may cause the printer to malfunction due to static electricity.
- Do not apply excessive force to the connectors. Doing so may damage the connectors.

Connector

USB Type-B (Standard-B) connector

USB transmission specifications

USB function

Item		Specifications
Overall specifications		According to USB 2.0 specifications
Transmission speed		USB Full-Speed (12 Mbps)
Transmission method		USB bulk transmission method
Power supply specifications		USB self power supply function
Current consumed by USB bus		2 mA
USB packet size (with full-speed connection)	USB bulk OUT (TM)	64 bytes
	USB bulk IN (TM)	64 bytes
USB device class		Both USB vendor-defined class and USB printer class are supported. For USB device class settings, see "Software Settings" on page 28

USB descriptor

		USB vendor-defined class	USB printer class
Vendor ID		04B8h	
Product ID		0202h	0E27h
String Descriptor	Manufacturer	EPSON	
	Product	TM-T82X-II	
	Serial number	Character string based on the product serial number	

RS-232 Serial Interface

Interface board specifications (RS-232-compliant)

Item		Specifications
Data transfer method		Serial
Synchronization		Asynchronous
Handshaking		Can be set using the commands, software settings mode, or TM-T82X-II Utility. <ul style="list-style-type: none"> • DTR/DSR • XON/XOFF
Signal level	MARK	-3 to -15 V logic "1"/OFF
	SPACE	+3 to +15 V logic "0"/ON
Bit length		Can be set using the commands, software settings mode, or TM-T82X-II Utility. <ul style="list-style-type: none"> • 7 bit • 8 bit
Transmission speed		Can be set using the commands, software settings mode, or TM-T82X-II Utility. 2400/4800/9600/19200/38400/57600/115200 bps [bps: bits per second]
Parity check		Can be set using the commands, software settings mode, or TM-T82X-II Utility. <ul style="list-style-type: none"> • Yes • No
Parity selection		Can be set using the commands, software settings mode, or TM-T82X-II Utility. <ul style="list-style-type: none"> • Even • Odd
Stop bit		1 or more bits However, the stop bit for data transfer from the printer is fixed to 1 bit.
Connector	Printer side	D-Sub 9-pin (male)

Functions of each connector pin

Pin no.	Signal name	Signal direction	Function
2	RXD	Input	Reception data
3	TXD	Output	Transmission data
4	DTR	Output	<p>When DTR/DSR control is selected, this signal indicates whether the printer is BUSY.</p> <ul style="list-style-type: none"> • SPACE status Indicates that the printer is ready to receive data. • MARK status Indicates that the printer is BUSY. Select the BUSY condition in the software setting mode. <p>When XON/XOFF control is selected, this signal indicates that the printer is properly connected and ready to receive data from the host.</p> <ul style="list-style-type: none"> • SPACE status The signal indicates that the printer is properly connected and ready to receive data from the host. <p>The signal is always SPACE, except in the following cases:</p> <ul style="list-style-type: none"> • During the period from when power is turned on to when the printer is ready to receive data. • While the self-test is in progress.
5	SG	-	Signal ground
6	DSR	Input	<p>This signal indicates whether the host computer can receive data. SPACE indicates that the host computer can receive data. MARK indicates that the host computer cannot receive data.</p> <p>When DTR/DSR control is selected, the printer transmits data after confirming this signal. (except if transmitted using some ESC/POS commands).</p> <p>When XON/XOFF control is selected, the printer does not check this signal.</p>
7	RTS	Output	Same as the DTR signal
Shell	-	-	Shield

XON/XOFF

When XON/XOFF control is selected, the printer transmits the XON or XOFF signals as follows.

The transmission timing differs, depending on the BUSY condition.

Signal	Printer status	BUSY condition	
		Receive buffer full	Receive buffer full/ Offline
XON	When the printer goes online after turning on the power (or reset using the interface)	Transmit	Transmit
	When the receive buffer is released from the buffer full state	Transmit	Transmit
	When the printer switches from offline to online	-	Transmit
	When the printer recovers from an error using some ESC/POS commands	-	Transmit
XOFF	When the receive buffer becomes full	Transmit	Transmit
	When the printer switches from online to offline	-	Transmit

Code

The hexadecimal numbers corresponding to the XON/XOFF codes are shown below.

- XON code: 11H
- XOFF code: 13H

Ethernet Interface

Communication specifications

10BASE-T/100BASE-TX

Support protocols

Protocols	Usage
IP, ARP, ICMP, UDP, TCP	Basic communication protocols
LP, LPR	Printing protocols
TCP Socket Port, Custom Raw Port	Used to transfer printing data and printer status via (bidirectional) direct socket communication.
HTTP/HTTPS	Used by browsers to display and set module status
SNMP	Used by dedicated and general MIB tools to acquire and set module and printer status
ENPC	Used to acquire and set module and printer status
DHCP	Used to acquire the IP address
APIPA	Used to assign the IP address

Network parameters

Item	Default settings
IP Address	192.168.192.168*
Subnet mask	255.255.255.0*
Default gateway	0.0.0.0*
IPv6 Address	Disabled
IP address acquisition	Automatic (DHCP)
APIPA	Disabled
IP Address Printing	Enabled
DNS Server Address Setting	Auto
Acquire host name automatically	Manual
Host Name	"EPSONXXXXXX" "XXXXXX" represents the bottom 6 digits of this product's MAC address.
Acquire domain name automatically	Auto
Domain Name	No

Item	Default settings
Register the network interface's address to DNS server	Manual
Administrator Name	No
Location	No
Password	Product serial number
Standard Community Name (Read Only)	"public"
Community name (Read Only)	No
Community name (Read/Write)	No
IP Trap #1-4	Disabled
Community Name (IP Trap #1-4)	No
IP Trap #1-4 Address	0.0.0.0
SNMPv3	Disabled
Socket Timeout	90 seconds
Time Server	Disabled
Time Server Status	Invalid
Time Server Address	0.0.0.0
Time Server Interval	60 minutes
Time Zone	±0 (UTC)
Bonjour	Enable
SLP	Enable
LLTD	Enable
LLMNR	Enable
SSL Encryption Strength	128 bit
https redirect	Enable
TLS1.0	Disabled
TLS1.1	Disabled
TLS1.2	Enable
MAC Address	Check the label on the product, the self-test, or the network status sheet.
Communication mode	Auto negotiation
Port Type	Auto

* Initial value when "Acquiring the IP Address" is set to Manual.

Character Code Tables

See the Character Code Tables for TM Printers that can be accessed from the following URL:

https://support.epson.net/publist/reference_en/