

TM-T82

Technical Reference Guide

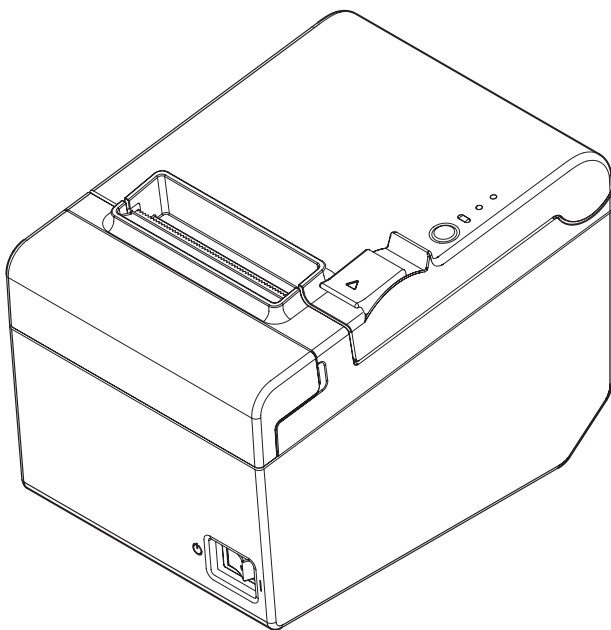

Product Overview

Describes features and general specifications for the product.

Setup

Describes setup and installation of the product and peripherals.

Application Development Information

Describes how to control the printer and necessary information when you develop applications.

Handling

Describes how to handle the product.

Appendix

Describes interfaces, connectors, and character code tables.

Cautions

- No part of this document may be reproduced, stored in a retrieval system, or transmitted in any form or by any means, electronic, mechanical, photocopying, recording, or otherwise, without the prior written permission of Seiko Epson Corporation.
- The contents of this document are subject to change without notice. Please contact us for the latest information.
- While every precaution has been taken in the preparation of this document, Seiko Epson Corporation assumes no responsibility for errors or omissions.
- Neither is any liability assumed for damages resulting from the use of the information contained herein.
- Neither Seiko Epson Corporation nor its affiliates shall be liable to the purchaser of this product or third parties for damages, losses, costs, or expenses incurred by the purchaser or third parties as a result of: accident, misuse, or abuse of this product or unauthorized modifications, repairs, or alterations to this product, or (excluding the U.S.) failure to strictly comply with Seiko Epson Corporation's operating and maintenance instructions.
- Seiko Epson Corporation shall not be liable against any damages or problems arising from the use of any options or any consumable products other than those designated as Original EPSON Products or EPSON Approved Products by Seiko Epson Corporation.

Trademarks

EPSON and ESC/POS are registered trademarks of Seiko Epson Corporation in Japan and other countries/regions.

Microsoft and Windows are registered trademarks of Microsoft Corporation.

ESC/POS[®] Command System

EPSON ESC/POS is a proprietary POS printer command system that includes patented or patent-pending commands. ESC/POS is compatible with all types of EPSON POS printers and displays (excluding the TM-C100 printer).



ESC/POS is designed to reduce the processing load on the host computer in POS environments. It comprises a set of highly functional and efficient commands and also offers the flexibility to easily make future upgrades.

Copyright © 2011 by Seiko Epson Corporation. All rights reserved.

For Safety

Key to Symbols

The symbols in this manual are identified by their level of importance, as defined below. Read the following carefully before handling the product.

 WARNING	You must follow warnings carefully to avoid serious bodily injury.
 CAUTION	Provides information that must be observed to prevent damage to the equipment or loss of data. <ul style="list-style-type: none">• Possibility of sustaining physical injuries.• Possibility of causing physical damage.• Possibility of causing information loss.
CAUTION	Provides information that must be observed to avoid damage to your equipment or a malfunction.
NOTE	Provides important information and useful tips.

Warnings



WARNING

- To avoid risk of electric shock, do not set up this product or handle cables during a thunderstorm
- **Never insert or disconnect the power plug with wet hands.**
Doing so may result in severe shock.
- **Handle the power cable with care.**
Improper handling may lead to fire or electric shock.
 - * Do not modify or attempt to repair the cable.
 - * Do not place any heavy object on top of the cable.
 - * Avoid excessive bending, twisting, and pulling.
 - * Do not place the cable near heating equipment.
 - * Check that the plug is clean before plugging it in.
 - * Be sure to push the plug all the way in.
- **Be sure to use the specified power source.**
Connection to an improper power source may cause fire or shock.
- **Do not place multiple loads on the power outlet.**
Overloading the outlet may lead to fire.
- **Shut down your equipment immediately if it produces smoke, a strange odor, or unusual noise.**
Continued use may lead to fire. Immediately unplug the equipment and contact your dealer or a Seiko Epson service center for advice.
- **Never attempt to repair this product yourself.**
Improper repair work can be dangerous.
- **Never disassemble or modify this product.**
Tampering with this product may result in injury or fire.
- **Do not allow foreign matter to fall into the equipment.**
Penetration by foreign objects may lead to fire.
- **If water or other liquid spills into this equipment, do not continue to use it.**
Continued use may lead to fire. Unplug the power cord immediately and contact your dealer or a Seiko Epson service center for advice.
- **Do not use aerosol sprayers containing flammable gas inside or around this product.**
Doing so may cause fire.

Cautions



- **Do not connect cables in ways other than those mentioned in this manual.**
Different connections may cause equipment damage or fire.
- **Be sure to set this equipment on a firm, stable, horizontal surface.**
The product may break or cause injury if it falls.
- **Do not use this product in locations subject to high humidity or dust levels.**
Excessive humidity and dust may cause equipment damage or fire.
- **Do not place heavy objects on top of this product. Never stand or lean on this product.**
Equipment may fall or collapse, causing breakage and possible injury.
- **Take care not to injure your fingers on the manual cutter**
 - * When you remove printed paper
 - * When you perform other operations such as loading/replacing roll paper
- **Do not open the roll paper cover without taking the necessary precautions, as this can result in injury from the autocutter fixed blade.**
- **To ensure safety, unplug this product before leaving it unused for an extended period.**

Restriction of Use

When this product is used for applications requiring high reliability/safety, such as transportation devices related to aviation, rail, marine, automotive, etc.; disaster prevention devices; various safety devices, etc.; or functional/precision devices, etc., you should use this product only after giving consideration to including fail-safes and redundancies into your design to maintain safety and total system reliability. Because this product was not intended for use in applications requiring extremely high reliability/safety, such as aerospace equipment, main communication equipment, nuclear power control equipment, or medical equipment related to direct medical care, etc., please make your own judgment on this product's suitability after a full evaluation.

About this Manual

Aim of the Manual

This manual was created to provide information on development, design, and installation of POS systems and development and design of printer applications for developers.

Manual Content

The manual is made up of the following sections:

Chapter 1	Product Overview
Chapter 2	Setup
Chapter 3	Application Development Information
Chapter 4	Handling
Appendix	Specifications of Interface and Connector Character Code Tables

Contents

■ For Safety	3
Key to Symbols	3
Warnings	4
Cautions.....	5
■ Restriction of Use	5
■ About this Manual	6
Aim of the Manual.....	6
Manual Content	6
<hr/>	
Product Overview	11
■ Features	11
■ Product Configurations	13
Interface	13
Colors	13
Accessories.....	13
■ Part Names and Functions	15
Power Switch	15
Power Switch Cover.....	15
Control Panel	16
Offline	17
Connectors.....	17
■ Error Status	18
Automatically Recoverable Errors	18
Recoverable Errors.....	18
Unrecoverable Errors	19
■ NV Memory (Non-Volatile Memory)	20
NV Graphics Memory.....	20
User NV Memory	20
Memory Switches.....	20
R/E (Receipt Enhancement)	21
User-defined Page	21
Maintenance Counter	21
■ Product Specifications	22
Printing Specifications	23
Character Specifications	25
Paper Specifications.....	27
Printable Area	28
Printing and Cutting Positions	29
Electrical Characteristics	30
Reliability	30
Environmental Conditions.....	31

External Dimensions and Mass.....	32
-----------------------------------	----

Setup 33

■ Flow of Setup.....	33
■ Installing the Printer.....	34
Installing the Printer Vertically	35
Hanging the Printer on a Wall	37
■ Adjusting the Roll Paper Near-End Sensor	39
■ Changing the Paper Width.....	40
■ Connecting the Printer to the Host Computer	41
For Serial Interface Model	41
For USB Interface Model	43
For Ethernet Interface	44
■ Connecting to the Power Source.....	46
Connecting the AC cable	46
■ Setting the Memory Switches/Receipt Enhancement.....	47
Functions	48
■ Connecting the Optional Buzzer Unit	55
Connecting the Buzzer Unit.....	55
■ Connecting the Cash Drawer	57
Connecting the Drawer Kick-out Cable.....	57
Drawer Connection Diagram	58

Application Development Information..... 59

■ How to Control the Printer.....	59
Selecting a Driver	59
ESC/POS Commands.....	60
■ Software and Manuals.....	66
Printer Drivers	66
Utilities	68
How to Get Drivers, Manuals, and the Utility.....	69
■ Setting/Checking Modes	70
Self-test Mode	70
Hexadecimal Dumping Mode.....	72
NV Graphics Information Print Mode	73
Receipt Enhancement Information Print Mode	75
Memory Switch Setting Mode	76

Handling 79

■ Installing and Replacing Roll Paper.....	79
■ Removing Jammed Paper.....	81
When the Roll Paper Cover Cannot be Opened.....	81
■ Cleaning the Printer.....	83
Cleaning the Printer Case	83
Cleaning the Thermal Head/Platen Roller.....	83
■ Preparing for Transport	84

Appendix..... 85

■ Specifications of Interface and Connector	85
USB (Universal Serial Bus) Interface	85
RS-232 Serial Interface	86
10BASE-T/100BASE-TX Ethernet Interface.....	89
■ Character Code Tables.....	91
Common to All Pages	91
Page 0 (PC437: USA, Standard Europe)	92
Page 1 (Katakana).....	93
Page 2 (PC850: Multilingual)	94
Page 3 (PC860: Portuguese).....	95
Page 4 (PC863: Canadian-French)	96
Page 5 (PC865: Nordic)	97
Page 11 (PC851: Greek)	98
Page 12 (PC853: Turkish)	99
Page 13 (PC857: Turkish)	100
Page 14 (PC737: Greek)	101
Page 15 (ISO8859-7: Greek)	102
Page 16 (WPC1252).....	103
Page 17 (PC866: Cyrillic #2).....	104
Page 18 (PC852: Latin2).....	105
Page 19 (PC858: Euro).....	106
Page 20 (KU42: Thai).....	107
Page 21 (TIS11: Thai)	108
Page 26 (TIS18: Thai)	109
Page 30 (TCVN-3: Vietnamese)	110
Page 31 (TCVN-3: Vietnamese)	111
Page 32 (PC720: Arabic)	112
Page 33 (WPC775: Baltic Rim).....	113
Page 34 (PC855: Cyrillic).....	114
Page 35 (PC861: Icelandic).....	115
Page 36 (PC862: Hebrew)	116
Page 37 (PC864: Arabic)	117
Page 38 (PC869: Greek)	118
Page 39 (ISO8859-2: Latin2)	119

Page 40 (ISO8859-15: Latin9).....	120
Page 41 (PC1098: Farsi)	121
Page 42 (PC1118: Lithuanian).....	122
Page 43 (PC1119: Lithuanian).....	123
Page 44 (PC1125: Ukrainian).....	124
Page 45 (WPC1250: Latin 2)	125
Page 46 (WPC1251: Cyrillic).....	126
Page 47 (WPC1253: Greek).....	127
Page 48 (WPC1254: Turkish)	128
Page 49 (WPC1255: Hebrew).....	129
Page 50 (WPC1256: Arabic).....	130
Page 51 (WPC1257: Baltic Rim)	131
Page 52 (WPC1258: Vietnamese)	132
Page 53 (KZ1048: Kazakhstan).....	133
Page 255 (User-Defined Page).....	134
International Character Sets.....	135

Product Overview

This chapter describes features and specifications of the product.

Features

Printing

- High speed receipt printing is possible (150 mm/s maximum).
- Shifting from 80 mm width paper printing to 58 mm width paper printing is available.

Handling

- Easy drop-in paper loading

Software

- Command protocol is based on the ESC/POS[®] Proprietary Command System.
- Windows printer drivers, OPOS ADK, OPOS for .NET ADK, JavaPOS ADK and other drivers (Linux CUPS, Mac driver) are available.
- Printing of various types of bar codes, GS1-DataBar, and two-dimensional symbols (PDF417, QR code, MaxiCode, Composite Symbology) is supported.
- A maintenance counter function is supported.
- Multiple languages are supported for code pages, Windows drivers, and utility software.

Interface

- USB, serial, and Ethernet interfaces are available.
- USB/Ethernet virtual serial interface and USB/Ethernet virtual parallel interface are supported.

Environmental

- The TM-T82 is ENERGY STAR qualified.

Others

- Various installation layouts (horizontal, vertical, and wall-hanging installation) are selectable.
- Software & Documents Disc is included containing drivers, utility software, and manuals.
- Optional buzzer unit is available.

Product Configurations

Interface

- USB interface model
- Serial interface model
- Ethernet interface model

Colors

- ECW (Epson Cool White)
- EDG (Epson Dark Gray)

Accessories

Included

- Roll paper (for operation check)
- Power switch cover
- Power switch waterproof cover
- Wall hanging bracket
- Screws for wall hanging bracket
- Rubber feet for vertical installation
- Control panel label for vertical installation
- 58-mm width paper guide plate
- TM-T82 Software & Documents Disc containing drivers, utilities, and documentation
- Setup Guide
- Interface cable*
- AC cable*
- Warranty certificate*

* May not be included depending on the model.

Options

- Affixing tape for fixing the printer (Model: DF-10)
- External buzzer unit (Model: OT-BZ20)

Part Names and Functions

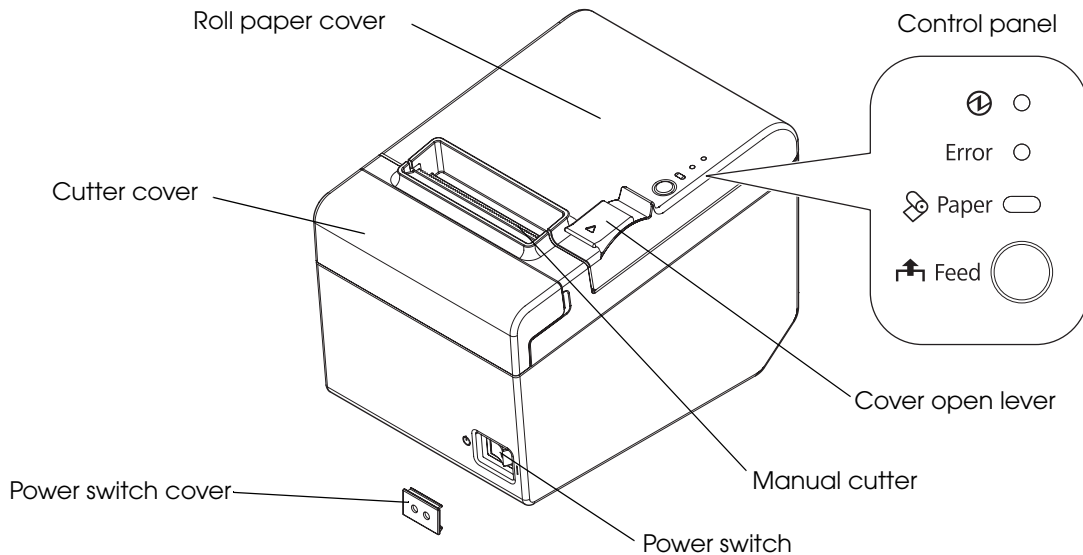

Power Switch

Turns the printer on or off. The marks on the switch: ( : OFF / | : ON)

NOTE

Before turning the printer off, it is recommended to send a power-off command to the printer. If you use the power-off sequence, the latest maintenance counter values are saved. (Maintenance counter values are usually saved every two minutes.) For information about ESC/POS commands, see the ESC/POS Application Programming Guide.

Power Switch Cover

Install the power switch cover that comes with the TM-T82 onto the printer to prevent inadvertent operation of the power switch and to prevent tampering. To reset the printer when the power switch cover is installed, insert a long, thin object (such as the end of a paper clip) into the hole in the power switch cover and press the power switch.

A waterproof cover for the power switch is also included.



If an accident occurs with the power switch cover attached, unplug the AC cable immediately.

Continued use of the printer may cause fire or shock.

CAUTION

Use the power switch waterproof cover if the printer is installed in a humid location or exposed to water. If current leakage occurs, it could result in electric shock.

Control Panel

NOTE

When installing the printer vertically or hanging the printer on a wall, be sure to attach the included control panel label for vertical installation on the roll paper cover. The control panel label for vertical installation is upside down.

① Power LED (green)

- Lights when the power supply is on.
- Goes out when the power supply is turned off.

Error LED (orange)

Lights or flashes when the printer is offline.

- Lights after the power is turned on or after a reset (offline). Automatically goes out after a while to indicate that the printer is ready.
- Lights when the end of the roll paper is detected, and when printing has stopped (offline). If this happens, replace the roll paper.
- Flashes when an error occurs. (For information about the flashing patterns, see "[Error Status](#)" on page 18.)
- Goes out during regular operation (online).

📄 Paper LED (orange)

- Lights when there is no more roll paper.
- Off when there is a sufficient amount of roll paper remaining.
- Flashes when a self-test is in progress or when macro execution standby state.

⬆️ Feed button

Pressing this button once feeds the roll paper by one line. Holding this button down feeds the roll paper continuously.

NOTE

- To make the Paper LED light up when the roll paper is nearly out, enable the roll paper near-end sensor with the memory switch. For information about the memory switch, see "[Setting the Memory Switches/Receipt Enhancement](#)" on page 47.
- Enabling/disabling of Feed button can be selected by a command. If the command is set to disable this button, it does not function.

Offline

The printer automatically goes offline under the following conditions:

- During power on until the printer is ready
- During the self-test
- While roll paper is fed using the Feed button
- When the printer stops printing due to a paper-end (if an empty paper supply is detected by the roll paper end sensor)
- During a macro execution standby state
- When an error has occurred

Connectors

All cables are connected to the connector panel on the lower rear of the printer.

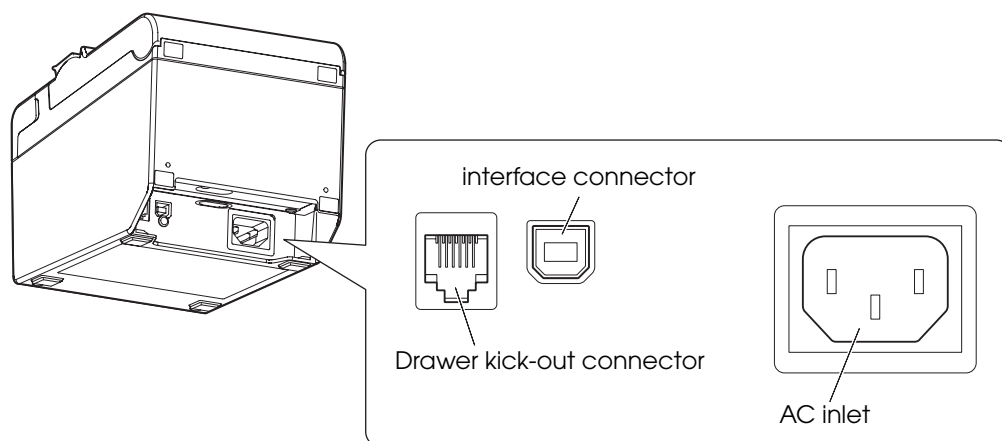

The picture above shows a USB interface model.

- **Drawer kick-out connector:** Connects the cash drawer or the optional external buzzer.
- **Interface connector:** Connects the printer with the host computer interface.
- **AC inlet:** Connects the AC cable.

CAUTION

For a USB interface, do not turn on the printer before installing the printer driver.

NOTE

For information about how to connect the interface connector, cash drawer, and optional external buzzer, see ["Connecting to the Power Source" on page 46](#), ["Connecting the Cash Drawer" on page 57](#), and ["Connecting the Optional Buzzer Unit" on page 55](#).

Error Status

There are three possible error types: automatically recoverable errors, recoverable errors, and unrecoverable errors.

Automatically Recoverable Errors

Printing is no longer possible when automatically recoverable errors occur. They can be recovered easily, as described below.

Error	Error description	Error LED flashing pattern	Recovery measure
Roll paper cover open error	The roll paper cover was opened during printing.	<p>LED ON → LED OFF →</p> <p>Approx. 160 ms →</p>	Recovers automatically when the roll paper cover is closed.
Print head temperature error	A high temperature outside the head drive operating range was detected.	<p>LED ON → LED OFF →</p> <p>Approx. 160 ms →</p>	Recovers automatically when the print head cools.

Recoverable Errors

Printing is no longer possible when recoverable errors occur. They can be recovered easily by turning the power on again or sending an error recovery command from the driver after eliminating the cause of the error.

Error	Error description	Error LED flashing pattern	Recovery measure
Autocutter error	Autocutter does not work correctly.	<p>LED ON → LED OFF →</p> <p>Approx. 2.56 s →</p> <p>Approx. 160 ms →</p>	Remove the jammed paper or foreign matter in the printer, close the roll paper cover, send the error recovery command, or turn the power on to recover.

CAUTION

The error recovery command is valid only if a recoverable error (excluding automatically recoverable errors) occurs.

Unrecoverable Errors

Printing is no longer possible when unrecoverable errors occur. The printer must be repaired.



Turn off the power immediately when an unrecoverable error occurs.

Error	Error description	Error LED flashing pattern
Memory R/W error	After R/W checking, the printer does not work correctly.	<p>LED ON → LED OFF →</p> <p>Approx. 160 ms →</p>
High voltage error	The power supply voltage is extremely high.	<p>LED ON → LED OFF →</p> <p>Approx. 160 ms →</p>
Low voltage error	The power supply voltage is extremely low.	<p>LED ON → LED OFF →</p> <p>Approx. 160 ms →</p>
CPU execution error	The CPU is executing an incorrect address.	<p>LED ON → LED OFF →</p> <p>Approx. 160 ms →</p>
Internal circuit connection error	Internal circuits are not connected correctly.	<p>LED ON → LED OFF →</p> <p>Approx. 2.56 s</p> <p>Approx. 160 ms →</p>

NV Memory (Non-Volatile Memory)

The printer's NV memory stores data even after the printer power is turned off. NV memory contains the following memory areas for the user:

- NV graphics memory
- User NV memory
- Memory switches
- R/E (Receipt Enhancement)
- User-defined page
- Maintenance counter

CAUTION

As a guide, NV memory rewriting should be used 10 times or less a day when you program applications.

NV Graphics Memory

Graphics, such as shop logos to be printed on receipts, can be registered. Even with a serial interface model whose communication speed is low, high speed graphic printing is possible. Use the TM-T82 Utility to register graphics. You can also use the TM-T82 Utility or the NV graphics information print mode to print and confirm the registered graphics.

NOTE

- For information about the TM-T82 Utility, see the TM-T82 Utility User's Manual.
- For information about how to use the NV graphics information print mode, see "[NV Graphics Information Print Mode](#)" on page 73.

User NV Memory

You can store and read text data for multiple purposes, such as for storing a note including customizing or maintenance information of the printer.

Use ESC/POS commands to store and read the text data.

NOTE

For information about ESC/POS commands, see the ESC/POS Application Programming Guide.

Memory Switches

With the memory switches, which are software switches for the printer, you can configure various settings of the printer. For information about the memory switch, see "[Setting the Memory Switches/Receipt Enhancement](#)" on page 47.

R/E (Receipt Enhancement)

Graphics, such as shop logos can be printed on top or bottom of receipts by setting R/E (Receipt Enhancement). For information about R/E, see "[Setting the Memory Switches/Receipt Enhancement](#)" on page 47.

User-defined Page

You can store character data in the user-defined page (character code table: page 255) so that you can also print characters not resident in the printer.

Maintenance Counter

With this function, printer information, such as the number of lines printed, the number of autcuts, and printer operation time after the printer starts working, is automatically stored in NV memory. You can read the information with the Status API of the APD or OPOS ADK to use it for periodical checks or part replacement.

NOTE

You can also check the head running length and number of times of autcutting with the self-test (see "[Self-test Mode](#)" on page 70.) and the TM-T82 Utility.

Product Specifications

Printing method	Thermal line printing	
Printing direction	Unidirectional with friction feed	
Resident font	Simplified Chinese models: Font A, Font B, Kanji South Asia models: Font A, Font B, Special Font A, Special Font B	
Paper feed speed	Approx. 150 mm/s {approx. 5.91"/s} (continuous paper feeding with the Feed button)	
Cutting method	Partial cut (cutting with one point in left edge left uncut)	
Interface	USB (USB 2.0, Full-speed (12 Mbps)), Serial (RS-232), Ethernet (10BASE-T/100BASE-TX)	
Buffers	Receive buffer	4 KB/45 bytes (selectable using the memory switch)
	Downloaded buffer (user-defined characters and user-defined images)	12 KB
	NV graphics memory	256 KB
	Download graphics memory	208 KB
	User NV memory	1KB
	User-defined page area	64 KB
Barcode/ two-dimensional symbol printing	UPC-A, UPC-E, JAN 8 (EAN 8), JAN 13 (EAN 13), CODE 39, ITF, CODABAR (NW-7), CODE 93, CODE 128, GS1-128, GS1 DataBar Omnidirectional, GS1 DataBar Truncated, GS1 DataBar Stacked, GS1 DataBar Stacked Omnidirectional, GS1 DataBar Limited, GS1 DataBar Expanded, GS1 DataBar Expanded Stacked, PDF417, QR CODE, MaxiCode, Composite Symbology	
Power supply	Supply voltage: AC100-240V 50/60Hz, Rated current: 1.0 A	
Temperature/humidity	Operating: 5 to 45°C {41 to 113°F}, 10 to 90% RH Storage: -10 to 50°C {14 to 122°F}, 10 to 90% RH	
Overall dimensions (H × W × D)	146 × 140 × 199 mm {5.75 × 5.51 × 7.83"}	
Weight (mass)	Approx. 1.7 kg {3.74 lb}	

Mbps: megabits per second

Printing Specifications

			80 mm width paper setting	58 mm width paper setting
Printing method			Thermal line printing	
Dot density			203 × 203 dpi	
Printing width	Normal mode (initial setting)		72.1 mm (2.84"), 576 dots	52.6 mm (2.07"), 420 dots
	42 column mode		68.3 mm (2.69"), 546 dots	47.3 mm (1.86"), 378 dots
Characters per line	Normal mode (initial setting)	Font A	48	35
		Font B	64	46
		Kanji	24	17
		Special Font A	48	35
		Special Font B	64	46
	42 column mode	Font A	42	42
		Font B	60	31
		Kanji	21	15
		Special Font A	42	42
		Special Font B	60	31
Character spacing	Normal mode (initial setting)	Font A	0.25 mm {0.0098"} (2 dots)	0.25 mm {0.0098"} (2 dots)
		Font B	0.25 mm {0.0098"} (2 dots)	0.25 mm {0.0098"} (2 dots)
		Kanji	0	0
		Special Font A	0.25 mm {0.0098"} (2 dots)	0.25 mm {0.0098"} (2 dots)
		Special Font B	0.25 mm {0.0098"} (2 dots)	0.25 mm {0.0098"} (2 dots)
	42 column mode	Font A	0.38 mm {0.015"} (3 dots)	0.25 mm {0.0098"} (2 dots)
		Font B	0.25 mm {0.0098"} (2 dots)	0.25 mm {0.0098"} (2 dots)
		Kanji	0.25 mm {0.0098"} (2 dots)	0
		Special Font A	0.38 mm {0.015"} (3 dots)	0.25 mm {0.0098"} (2 dots)
		Special Font B	0.25 mm {0.0098"} (2 dots)	0.25 mm {0.0098"} (2 dots)
Line spacing			3.75 mm {1/5"} (initial setting, programmable by command)	
Maximum print speed*			150 mm/s {5.91"/s}	

dpi: dots per inch

*: when the printer prints with the standard print density level at 25°C {77°F}.

CAUTION

- To change the paper width, you need to install the 58-mm width paper guide plate and to make the paper width setting with the memory switch. For information about how to change the paper width, see ["Changing the Paper Width" on page 40](#).
- Because some parts of the print head and the autocutter contact the platen and they may become worn out, once you change the paper width from 80 to 58 mm and use the printer, you cannot change it back to 80 mm.

NOTE

Printing speed may be slower, depending on the such items as the data transmission speed.

Character Specifications

			80 mm width paper setting	58 mm width paper setting
Number of characters			Alphanumeric characters: 95 Extended graphics: 128 × 43 pages (including user-defined page) International characters: 18 sets	
Character structure	Normal mode (initial setting)	Font A	12 × 24 (including 2-dot horizontal spacing)	
		Font B	9 × 17 (including 2-dot horizontal spacing)	
		Kanji	24 × 24	
		Special Font A	12 × 24 (including 2-dot horizontal spacing)	
		Special Font B	9 × 24 (including 2-dot horizontal spacing)	
	42 column mode	Font A	13 × 24 (including 3-dot horizontal spacing)	9 × 17 (including 2-dot horizontal spacing)
		Font B	9 × 17 (including 2-dot horizontal spacing)	12 × 24 (including 2-dot horizontal spacing)
		Kanji	26 × 24 (including 2-dot horizontal spacing)	24 × 24
		Special Font A	13 × 24 (including 3-dot horizontal spacing)	9 × 24 (including 2-dot horizontal spacing)
		Special Font B	9 × 24 (including 2-dot horizontal spacing)	12 × 24 (including 2-dot horizontal spacing)

Character size* (Standard/ Double-height/ Double-width/ Double-height, double-width)	Normal mode (initial setting)	Font A	1.25 × 3.00 mm/1.25 × 6.00 mm/ 2.50 × 3.00 mm/2.50 × 6.00 mm	
		Font B	0.88 × 2.13 mm/0.88 × 4.26 mm/ 1.76 × 2.13 mm/1.76 × 4.26 mm	
		Kanji	3.00 × 3.00 mm/3.00 × 6.00 mm/ 6.00 × 3.00 mm/6.00 × 6.00 mm	
		Special Font A	1.25 × 3.00 mm/1.25 × 6.00 mm/ 2.50 × 3.00 mm/2.50 × 6.00 mm	
		Special Font B	0.88 × 3.00 mm/0.88 × 6.00 mm/ 1.76 × 3.00 mm/1.76 × 6.00 mm	
	42 column mode	Font A	1.25 × 3.00 mm/ 1.25 × 6.00 mm/ 2.50 × 3.00 mm/ 2.50 × 6.00 mm	0.88 × 2.13 mm/ 0.88 × 4.26 mm/ 1.76 × 2.13 mm/ 1.76 × 4.26 mm
		Font B	0.88 × 2.13 mm/ 0.88 × 4.26 mm/ 1.76 × 2.13 mm/ 1.76 × 4.26 mm	1.25 × 3.00 mm/ 1.25 × 6.00 mm/ 2.50 × 3.00 mm/ 2.50 × 6.00 mm
		Kanji	3.00 × 3.00 mm/3.00 × 6.00 mm/ 6.00 × 3.00 mm/6.00 × 6.00 mm	
		Special Font A	1.25 × 3.00 mm/ 1.25 × 6.00 mm/ 2.50 × 3.00 mm/ 2.50 × 6.00 mm	0.88 × 3.00 mm/ 0.88 × 6.00 mm/ 1.76 × 3.00 mm/ 1.76 × 6.00 mm
		Special Font B	0.88 × 3.00 mm/ 0.88 × 6.00 mm/ 1.76 × 3.00 mm/ 1.76 × 6.00 mm	1.25 × 3.00 mm/ 1.25 × 6.00 mm/ 2.50 × 3.00 mm/ 2.50 × 6.00 mm

*: Space between characters is not included.

Characters can be scaled up to 64 times as large as the standard size.



Special Font A and Special Font B are the fonts for printing Thai characters and mounted only in the South Asia models.

Paper Specifications

		80 mm width paper setting	58 mm width paper setting
Paper types		Specified thermal paper	
Form		Roll paper	
Size	Roll paper diameter	83 mm {3.27"} maximum	
	Roll paper spool	Inside: 12 mm {0.47"}, Outside: 18 mm {0.71"}	
	Roll width when taken up	80 + 0.5/-1.0 mm	58 + 0.5/-1.0 mm
	Paper width	79.5 ± 0.5 mm	57.5 ± 0.5 mm
Specified roll paper type		NTP080-80	NTP058-80

CAUTION

- Paper must not be pasted to the roll paper spool.
- For the best print quality for each paper type, it is recommended to set the print density. (See "[Setting the Memory Switches/Receipt Enhancement](#)" on page 47.)

Printable Area

80 mm paper width setting

The maximum printable area of paper with a width of 79.5 ± 0.5 mm $\{3.13 \pm 0.02\}$ " is 72.1 ± 0.2 mm $\{2.84 \pm 0.008\}$ " (576 dots) and the approximate space is 3.0 mm $\{0.12\}$ " on the left side on the left side and 4.5 mm $\{0.18\}$ " on the right side.

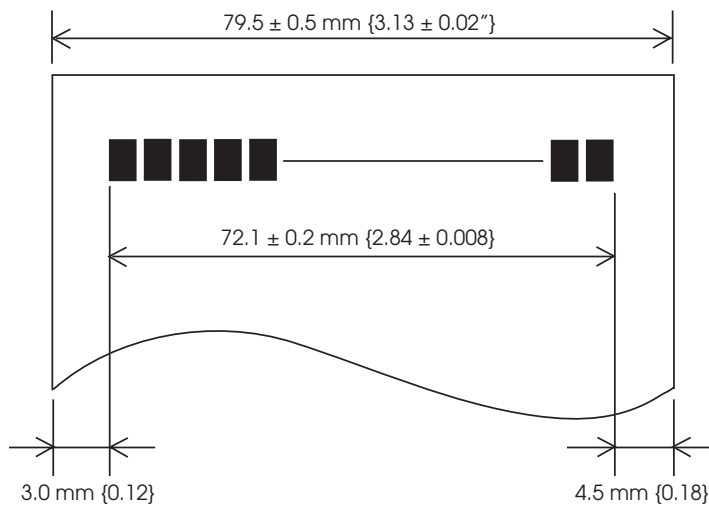

58 mm paper width setting

The maximum printable area of paper with a width of 57.5 ± 0.5 mm $\{2.26 \pm 0.02\}$ " is 52.6 ± 0.2 mm $\{2.07 \pm 0.008\}$ " (420 dots), and the approximate space is 3.0 mm $\{0.12\}$ " on the left side and 2.0 mm $\{0.079\}$ " on the right side.

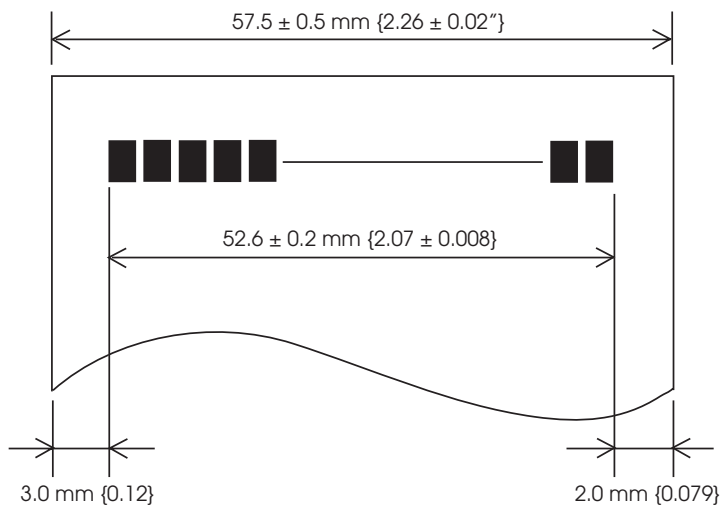

Printing and Cutting Positions

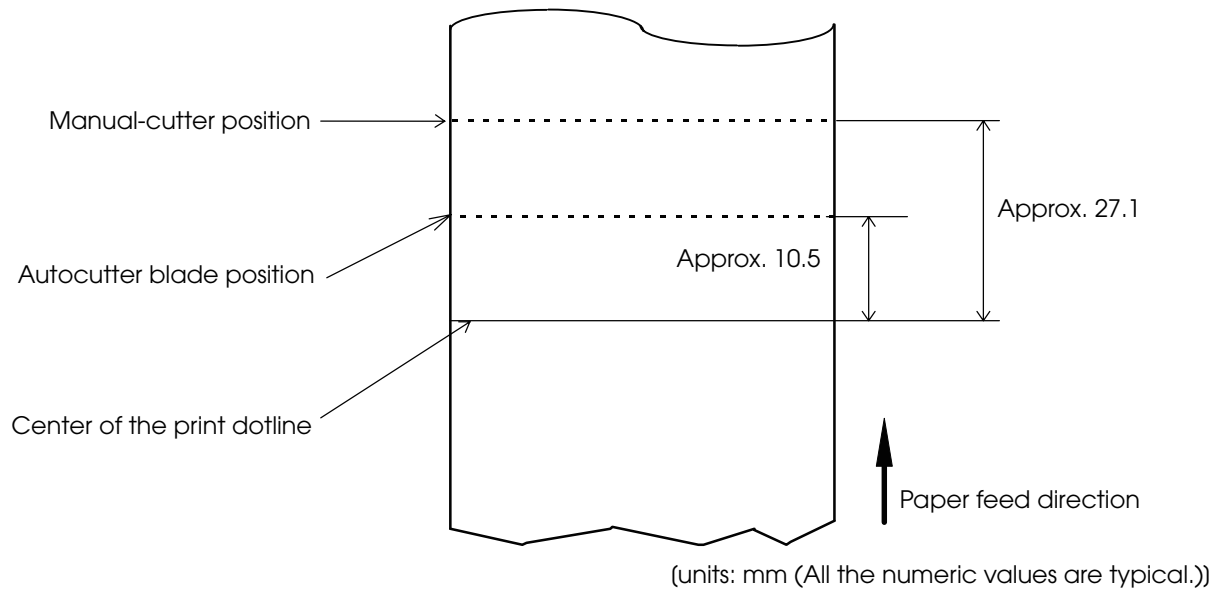
**CAUTION**

The values above may vary slightly as a result of paper slack or variations in the paper. Take this into account when setting the cutting position of the autocutter.

Electrical Characteristics

Supply voltage	AC 100-240V 50/60 Hz
Rated current	1.0 A

Note on printing with a high print ratio

If printing is continuously performed with a high print ratio, the overcurrent protection may be activated and result in uneven print density or a low voltage error. Therefore, the printing length must not exceed the following values when printing with high print ratio.

Print ratio: Number of dots being energized per one dot line / Total number of dots per one dot line (576 dots)

Maximum permissible printing length on print ratio

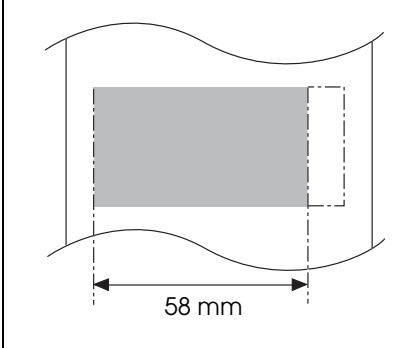
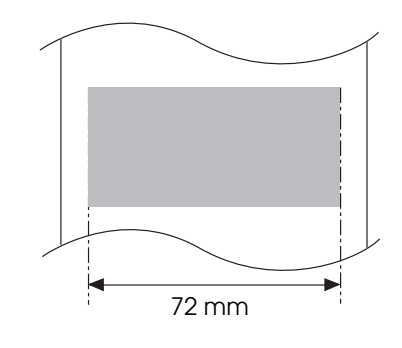
Print ratio	80%	100%
Print example		
Print length	30 mm	20 mm

Reliability

Life	Printer mechanism	15,000,000 lines (printing + paper feeding)
	Thermal head	100 million pulses, 100 km
	Autocutter	1,500,000 cuts
	MTBF	360,000 hours
	MCBF	60,000,000 lines

Environmental Conditions

Temperature/ Humidity	Operating	5 to 45°C {41 to 113°F}, 10 to 90% RH (See the operating temperature and humidity range below.)
	Storage	-10 to 50°C {14 to 122°F}, 10 to 90% RH (except for paper)
		<p>The graph illustrates the operating environment range. The vertical axis represents Relative humidity (%RH) from 0 to 90 in increments of 10. The horizontal axis represents Ambient temperature (°C) from 0 to 50 in increments of 10. A shaded teal area defines the operating range. It starts at 10% RH for temperatures between 5°C and 34°C. At 34°C, the humidity is 90%. From 34°C to 40°C, the humidity decreases to 65%. From 40°C to 45°C, it further decreases to 50%. The area is labeled 'Operating environment range'.</p>
Acoustic noise (operating)		<p>Approximately 55 dB (bystander position)</p> <p>Note:</p> <p>The values above are measured in the Epson evaluation condition.</p> <p>Acoustic noise differs depending on the paper used, printing contents, and the setting values, such as print speed or print density.</p>

External Dimensions and Mass

- Height: Approximately 146 mm {5.75"}
- Width: Approximately 140 mm {5.51"}
- Depth: Approximately 199 mm {7.83"}
- Mass: Approximately 1.7 kg {3.74 lb} (except for roll paper)

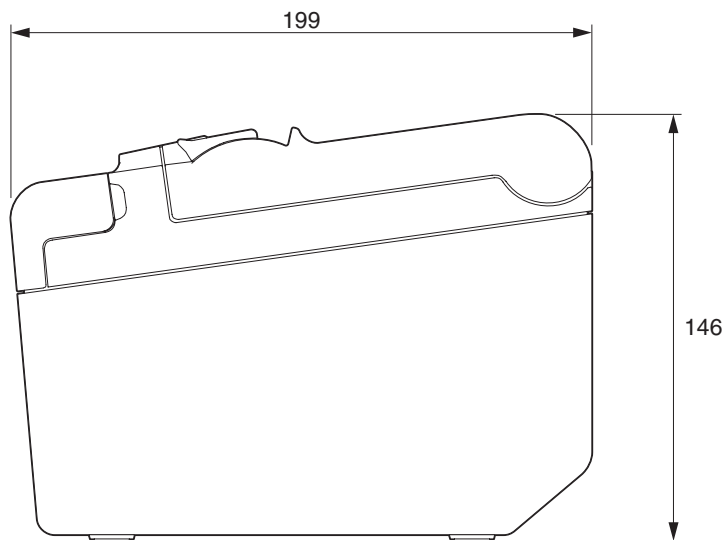
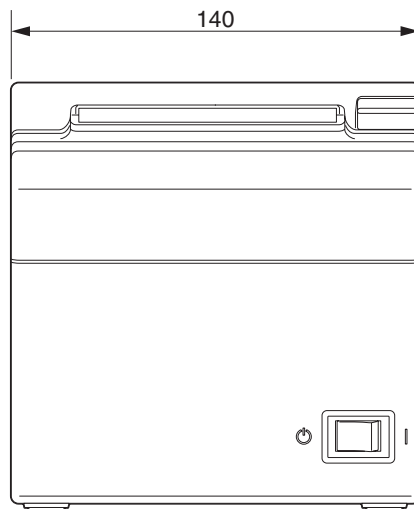

(Units: mm)

Setup

This chapter describes setup and installation of the product and peripherals.

Flow of Setup

This chapter consists of the following sections along with the setup flow of the product and peripherals.

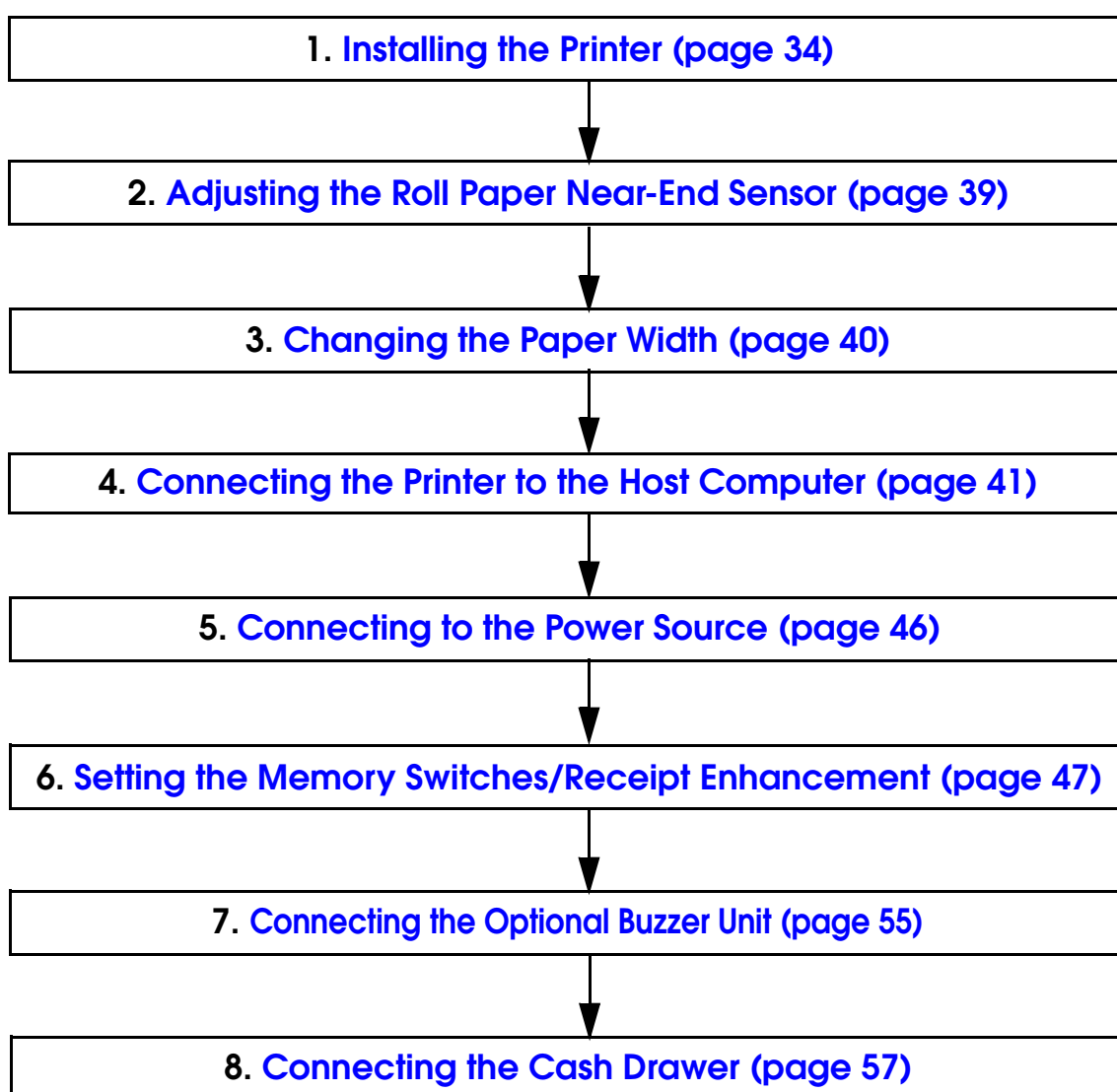

Installing the Printer

You can install the printer horizontally on a flat surface (with the paper exit on top) or vertically (with the paper exit at the front). Also, you can hang it on a wall using the included accessories.

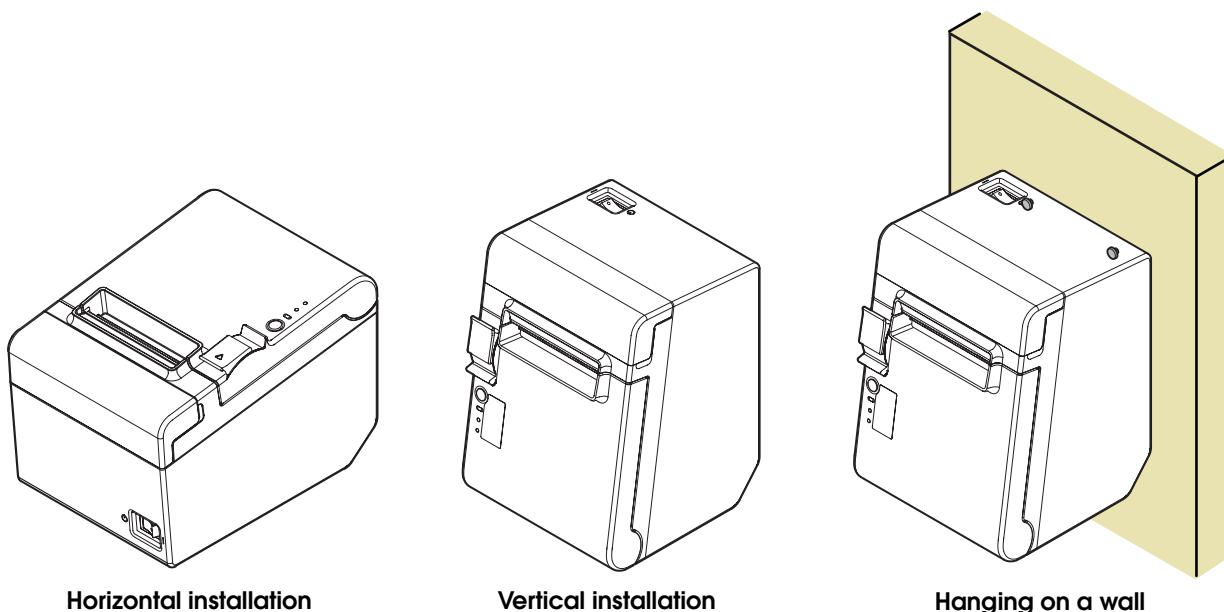

CAUTION

- Take measures to prevent the printer from moving by vibration during paper cutting and when using a drawer. Affixing tape (Model: DF-10) is provided as an option.
- Do not place the printer in dusty locations.
- Do not knock or strike the printer. This may cause defective print.
- Do not catch cables or foreign matter under the printer.
- You can use the roll paper near-end sensor only when you install the printer horizontally.
- When you install the printer vertically or hang it on a wall, make sure that the roll paper near-end sensor is disabled with the memory switch. For information about the memory switch, see "[Setting the Memory Switches/Receipt Enhancement](#)" on page 47.

Installing the Printer Vertically

When installing the printer vertically, be sure to attach the included control panel label for vertical installation on the roll paper cover, and attach 4 rubber feet in the rectangular indents in the printer case, as shown in the illustration below.

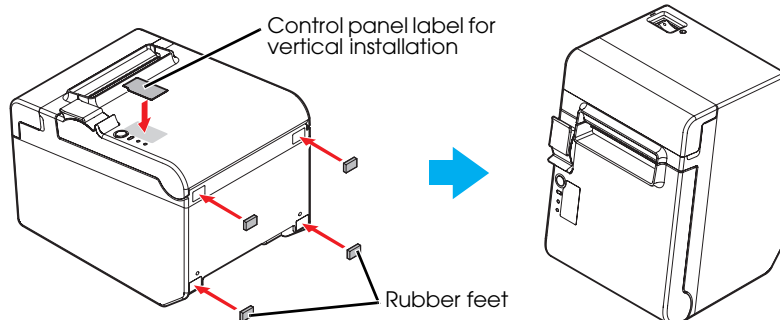

Vertical installation

You can install the printer so that the roll paper cover is upright to the mounting surface using the included wall hanging bracket.

- 1 Attach the control panel label for vertical installation on the roll paper cover.

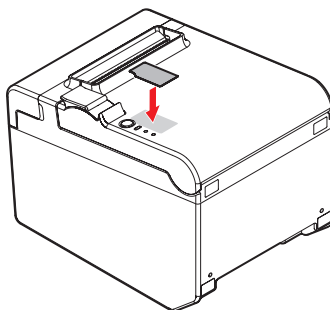

- 2 Install the wall hanging bracket on the printer, and fix it using 2 included screws.

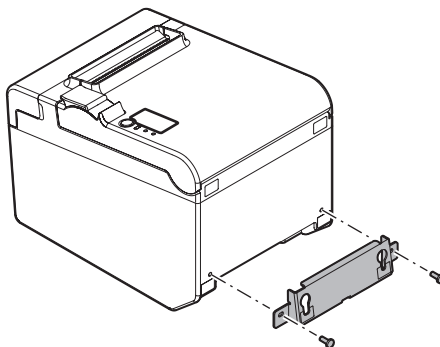

- 3** Attach 2 rubber feet in the rectangular indents in the printer case, and attach 2 rubber feet within the scribed line on the hanging bracket.

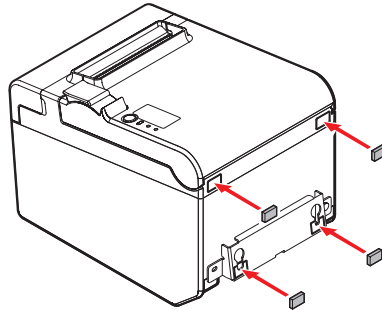

- 4** Place the printer with the wall-hanging-bracket-side down.

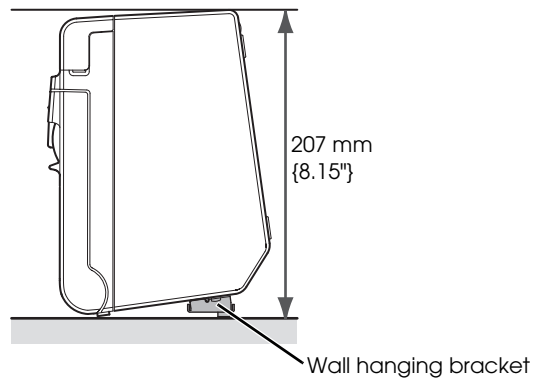

Hanging the Printer on a Wall

To hang the printer on the wall, follow the steps below.

CAUTION

- To fix the printer securely, install the wall hanging bracket on a wall made of wood, concrete, or metal. The thickness of the wall should be 10 mm {0.4"} or more.
- Be sure to use metallic screws.
- The screws on the wall side must have a pull-out strength of 150 N (15.3 kgf) or more.

- 1 Attach the included control panel label for vertical installation on the roll paper cover.

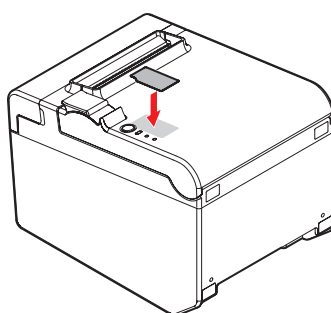

- 2 Install 2 screws (screw diameter: 4 mm {0.16"}, head diameter: 7 to 9 mm {0.28 to 0.35"}) in the wall at an interval of 80 mm {3.15"}.

Make sure the length of the screw's body in the wall is 10 mm {0.39"} or more, and the length outside the wall is 3 to 4 mm {0.12 to 0.16"}.

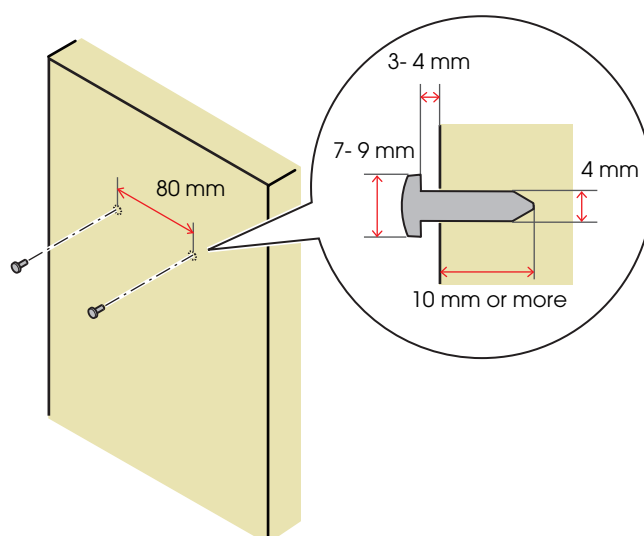

- 3** Remove the installed 2 screws from the printer, install the wall hanging bracket on the printer, and fix it using the screws.

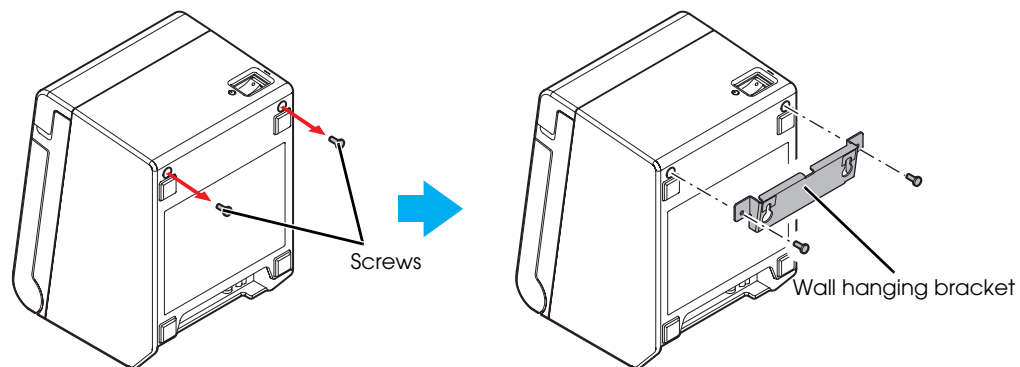

- 4** Align the holes in the wall hanging bracket with the screws on the wall, and hook it securely.

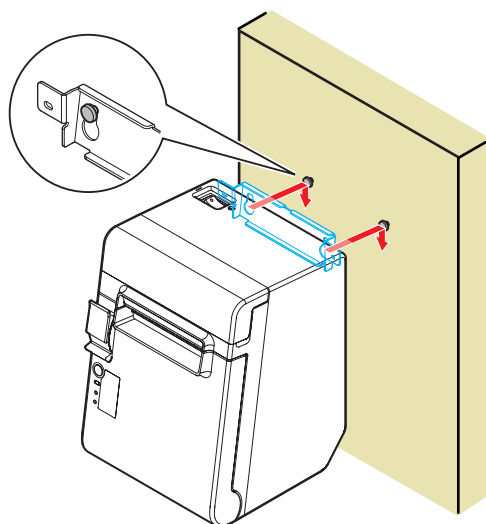

Adjusting the Roll Paper Near-End Sensor

When you install the printer horizontally, you can use the roll paper near-end sensor.

Below are two situations where a roll paper NE sensor adjustment is required.

- To adjust the detection position to suit the diameter of the roll paper core used.
- To adjust the detection position of remaining amount of paper.

CAUTION

- Since roll paper cores vary slightly in shape, depending on roll paper design and manufacturing tolerances, it is impossible to detect the remaining paper exactly.
- Use roll paper with a core inner diameter of 12 mm {0.47"} and outer diameter of 18 mm {0.71"} so that the NE sensor can detect the remaining paper as accurately as possible.
- The roll paper near-end sensor is initially disabled. To enable it, you need to set with the memory switch. For information about the memory switch, see ["Setting the Memory Switches/Receipt Enhancement" on page 47](#).

Follow the steps below to adjust the roll paper near-end sensor.

- 1 Open the roll paper cover, and remove the roll paper.
- 2 Loosen the adjustment screw fastening the sensor, and align the upper edge of the positioning plate with the adjustment position.

Adjustment position	Remaining amount of paper (outer diameter: mm)
Upper	Approx. 27 {1.06"}
Lower (Initial setting)	Approx. 23 {0.97"}

- 3 Tighten the adjustment screw.
- 4 After adjustment, make sure that the detection lever operates smoothly.

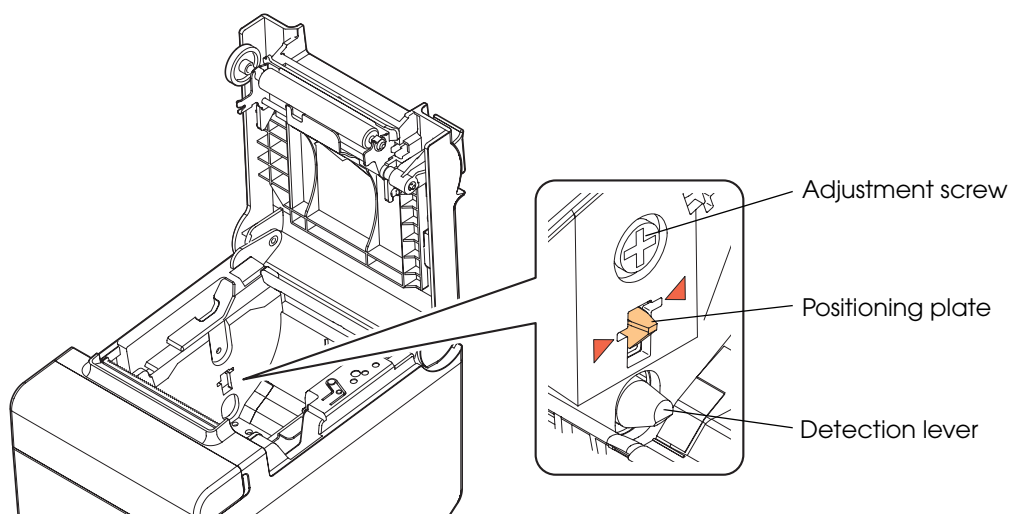

Changing the Paper Width

You can change the paper width from 80 to 58 mm by installing the included 58-mm width paper guide plate. Follow the steps below to change the paper width.

CAUTION

- Because some parts of the print head and the autocutter contact the platen and they may become worn out, once you change the paper width from 80 to 58 mm and use the printer, you cannot change it back to 80 mm.
- When changing the paper width, be sure to make the setting for the paper width with the memory switch. For information about the memory switch, see ["Setting the Memory Switches/Receipt Enhancement"](#) on page 47.

- 1 Open the roll paper cover.
- 2 Align 3 projections on the 58-mm width paper guide plate with the rectangular holes in the printer, and push it downwards.

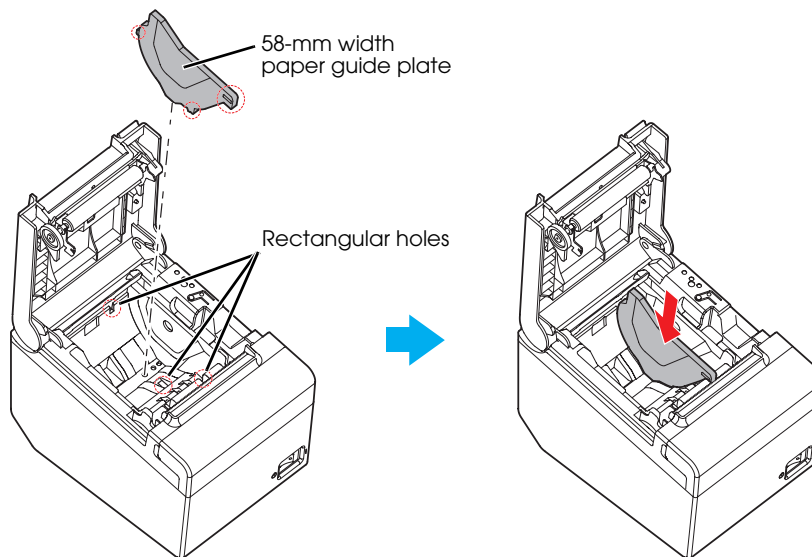

Connecting the Printer to the Host Computer

CAUTION

- Be sure to install the printer driver before connecting the printer to the host computer.
- The printer uses modular connectors specifically designed for the cash drawer. Do not connect the connector to an ordinary telephone line.

For Serial Interface Model

Serial interface connection diagram

When this printer is connected to a host computer by the serial interface, two connection forms are possible; stand alone connection and pass-through connection.

NOTE

The modular cable is mounted on the cash drawer.

Stand alone connection

This printer is connected to the host computer directly via the serial port. When a customer display (DM-D) is to be connected, connect it to the host computer via the serial port.

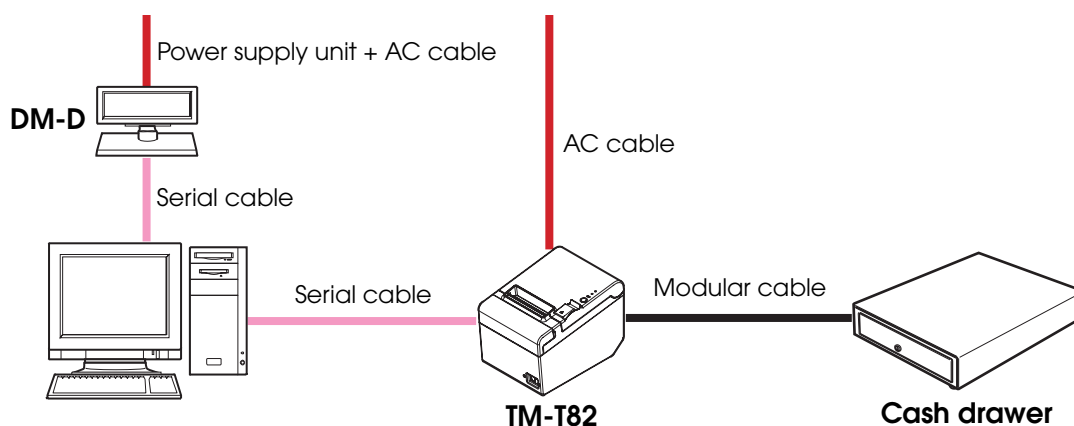

Pass-through connection

This printer is connected to the host computer through the serial interface via the customer display (DM-D).

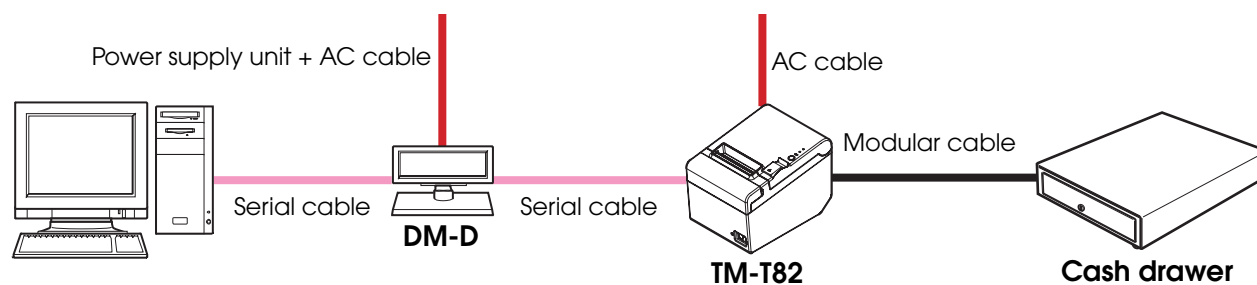

Connecting the serial interface (RS-232) cable



Be sure to turn off the power supply for both the printer and host computer before connecting the cables.

- 1** Insert the serial cable connector firmly into the interface connector.
When using connectors equipped with screws, tighten them to secure the connectors firmly.
When using interface cables equipped with a grounding line, attach the ground line to the screw hole marked "FG" on the printer.

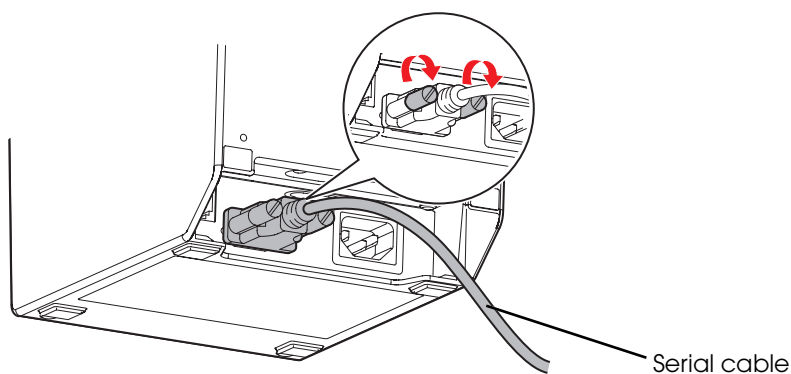

- 2** Connect the other end of the serial cable to the host computer.

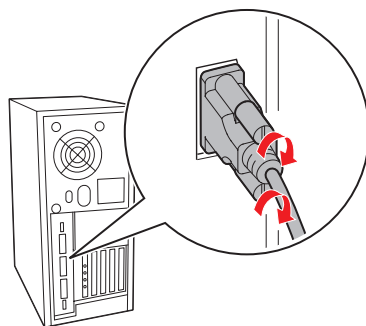

For USB Interface Model

USB interface connection diagram

This printer is connected to the host computer via the USB port. When a customer display (DM-D) is to be connected, connect it to the host computer via the serial port.

NOTE

The modular cable is mounted on the cash drawer.

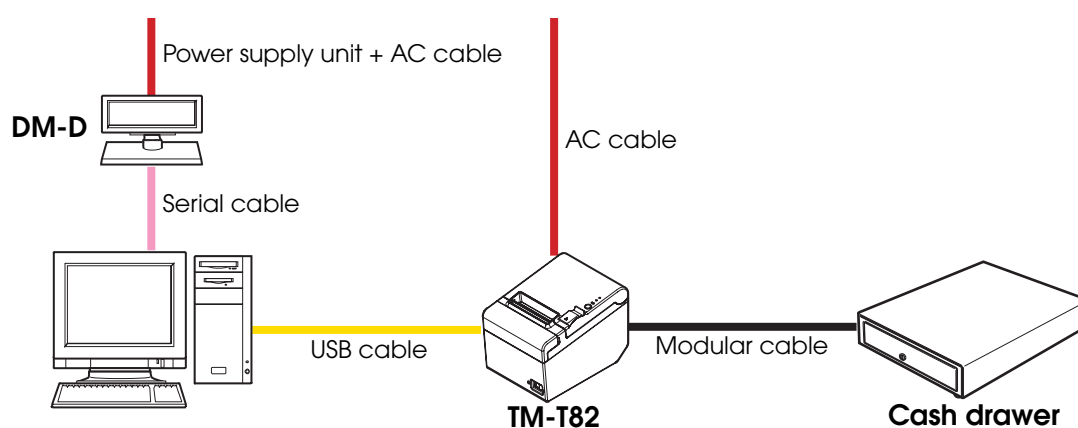

Connecting the USB interface cable

- 1 Connect the USB cable to the USB upstream connector.

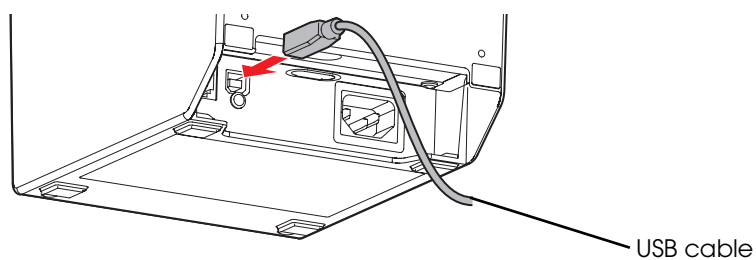

- 2 Connect the other end of the USB cable to the host computer.

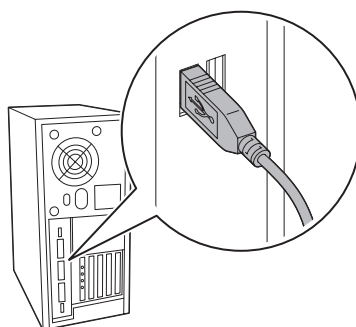

For Ethernet Interface

Connect the printer to a network by a LAN cable via a hub.

Ethernet interface connection diagram

NOTE

The modular cable is mounted on the cash drawer.

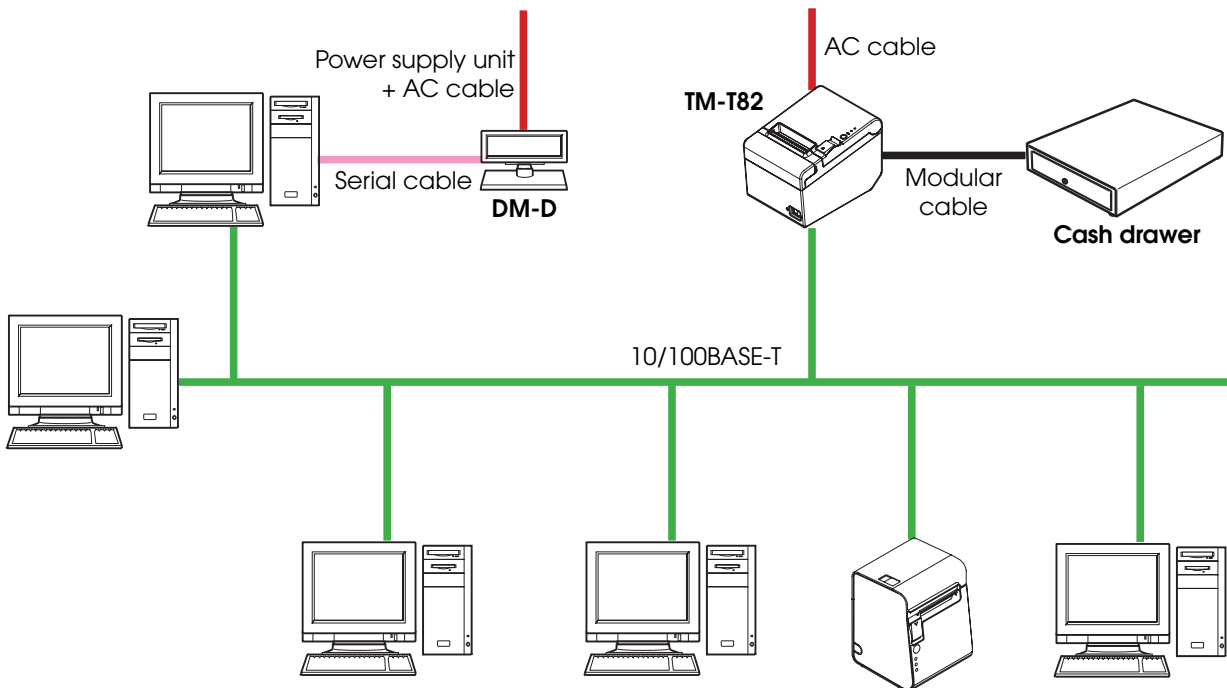

Connecting the Ethernet interface cable



CAUTION

- **When LAN cables are installed outdoors, make sure devices without proper surge protection are cushioned by being connected through devices that do have surge protection.**
Otherwise, the devices can be damaged by lightning.
- **Never attempt to connect the customer display cable, drawer kick-out cable, or a standard telephone line cable to the 10/100BASE-T LAN connector.**

NOTE

To use the Ethernet interface, the IP Address Setup Utility for UB-E03 is required. For detailed information about the setup methods, see “Setting IP Address Using EPSON TMNet WinConfig“, “Setting IP Address Using arp/ping Command“, “Checking/Changing the Settings“, “Initializing“, and “ESPON TMNet WebConfig” in the UB-E03 Technical Reference Guide. You can obtain the IP Address Setup Utility for UB-E03 and the UB-E03 Technical Reference Guide from one of the following URLs or ask your dealer:

- For customers in North America, go to the following web site:
<http://www.epsonexpert.com/>
- For customers in other countries, go to the following web site:
<http://www.epson-pos.com/>

Connect a 10/100BASE-T cable to the 10/100BASE-T LAN connector by pressing firmly until the connector clicks into place.

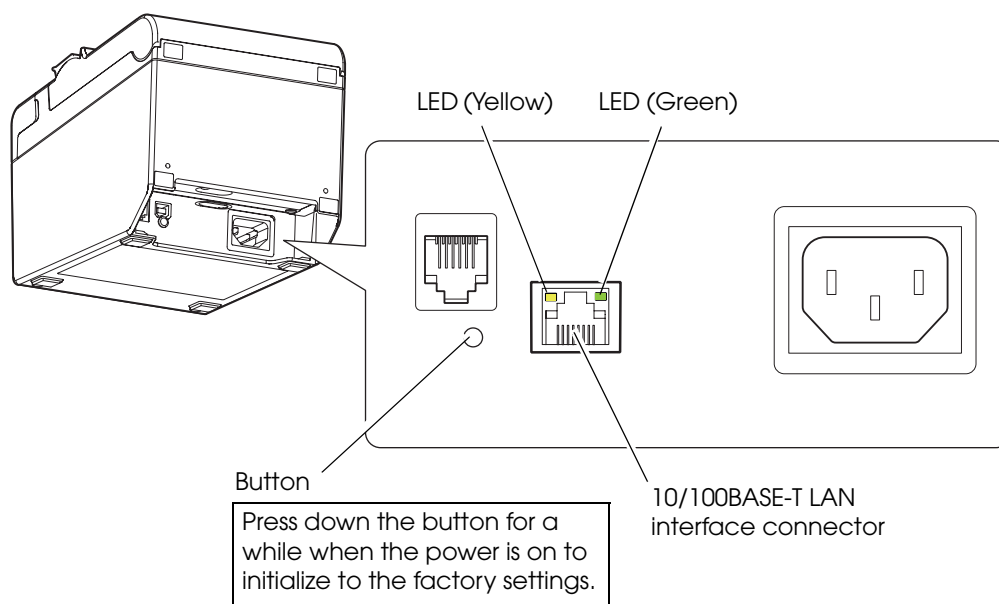

Connecting to the Power Source



- **Never insert the AC cable plug into a socket that does not meet the rated voltage requirements of the printer.** Doing so may result in damage to the printer.
- **Should a fault ever occur, immediately turn off the power to the printer and unplug the AC cable from the wall socket.**

Be sure to use the included AC cable.

Connecting the AC cable

- 1** Make sure the printer is turned off.
- 2** Connect the AC cable to the AC inlet.

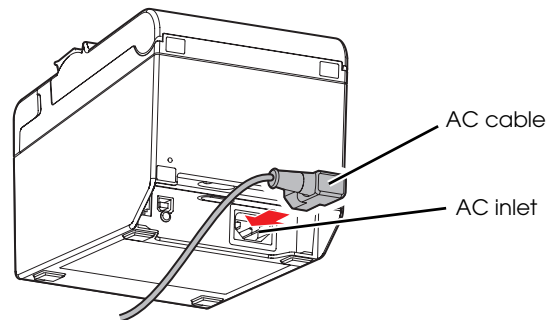

- 3** Insert the AC plug into a wall socket.

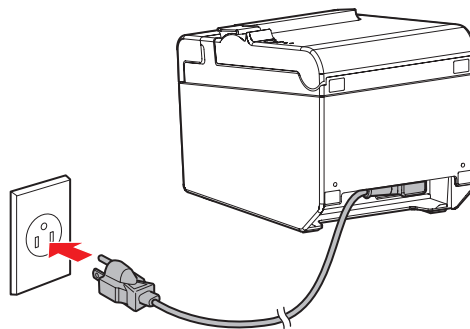

CAUTION

Do not turn on the printer before installing the printer driver.

Setting the Memory Switches/Receipt Enhancement

With the memory switch and R/E (receipt enhancement) function, which are software settings for this printer, you can set the various functions. For an outline of the functions, see the following section. Use the methods shown in the table below; TM-T82 Utility, Memory Switch Setting Mode, or ESC/POS commands, to set the memory switches and R/E functions.

Item\Method		TM-T82 Utility	Memory Switch Setting Mode	ESC/POS Commands	
Memory Switches	Receive buffer capacity		✓	✓	
	BUSY condition		✓	✓	
	Processing when data receive error		✓	✓	
	Auto line feed		✓	✓	
	USB power-saving function		✓	✓	
	Release condition of receive buffer BUSY		✓	✓	
	Roll paper near-end detection	✓	✓	✓	
	Customized Values	Roll paper width	✓	✓	✓
		Print density	✓	✓	✓
		Print speed	✓	✓	✓
		Thai character print mode*		✓	✓
		Character code table default	✓	✓	✓
		International character default	✓	✓	✓
		Number of columns	✓	✓	✓
		Autocutting after closing cover	✓	✓	✓
		Font A auto replacement		✓	✓
		Font B auto replacement	✓	✓	✓
		Optional buzzer	✓	✓	✓
		Logo 180 dpi emulation mode	✓	✓	✓
		Communication condition of USB interface	✓	✓	✓
Communication condition of serial interface	✓	✓	✓		
Receipt Enhancement	Auto top logo	✓		✓	
	Auto bottom logo	✓		✓	
	Top logo when printer is powered on	✓		✓	
	Top logo when cover is closed	✓		✓	

dpi: dots per inch

*: Enabled only for South Asia models

NOTE

- For information about the TM-T82 Utility, see the TM-T82 Utility User's Manual.
- For information about how to use the memory switch setting mode, see "[Memory Switch Setting Mode](#)" on page 76.
- For information about ESC/POS commands, see the ESC/POS Application Programming Guide.

Functions

Receive buffer capacity

- 4KB (initial setting)
- 45 bytes

BUSY condition

- Receive buffer full/Offline (initial setting)
- Receive buffer full

CAUTION

- In either case above, the printer enters the BUSY state after power is turned on, and when a self-test is being run.
- If BUSY condition is set to "Receive buffer full," the printer will not become BUSY
 - * When the cover is open
 - * When paper is fed by the FEED button
 - * When printing has stopped for a paper out
 - * When macro execution ready state
 - * When error has occurred

Processing when data receive error

- Prints "?" (initial setting)
- Ignored

Auto line feed

- Always enabled (initial setting)
- Always disabled

USB power-saving function

- Disabled (initial setting)
- Enabled

CAUTION

The USB power-saving function is valid only when the USB interface communication condition is set to the vendor-defined class and the system configuration is set so that the USB driver can support the USB power-saving function.

Release condition of receive buffer BUSY

- Releases when the remaining receive buffer capacity becomes 256 bytes (initial setting)
- Releases when the remaining receive buffer capacity becomes 138 bytes

Roll paper near-end detection

- Disabled (initial setting)
- Enabled

CAUTION

- You can use the roll paper near-end sensor only when you install the printer horizontally. When you install the printer vertically or hang it on a wall, be sure to disable the setting. Otherwise false detections occur.
- You may need to adjust the roll paper near-end sensor. For information about how to adjust it, see "[Adjusting the Roll Paper Near-End Sensor](#)" on page 39.

Roll paper width

- 80 mm (initial setting)
- 58 mm

CAUTION

- To change the paper width, you need to install the 58-mm width paper guide plate. For information about how to change the paper width, see "[Changing the Paper Width](#)" on page 40.
- Because some parts of the print head and the autocutter contact the platen and they may become worn out, once you change the paper width from 80 to 58 mm and use the printer, you cannot change it back to 80 mm.

Setting the print density

Selectable from levels 1 to 7 (85% ~ 115%).

Initial setting: level 4 (standard)

Depending on the paper type, it is recommended to set the print density as shown in the table below for the best print quality.

Original Paper type	Density Level
TF50KS-E, TF60KS-E, PD150R, PD160R, PD190R, P220AGB-1, P30023, P31023, P35023, AF50KS-E, KT55F20, KT48F20	4 (100%)
F5041	5 (105%)

CAUTION

When the print density level is increased, printing speed may be reduced.

Print speed

Selectable from levels 1 to 13 (Slow ~ Fast)

Initial setting: level 13

NOTE

Depending on print conditions, such as print duty, print head temperature, and data transmission speed, print speed is automatically adjusted, which may cause white lines due to intermittent print (the motor sometimes stops). To avoid this, keep the print speed constant by setting it lower, or set the transmission speed higher for the serial interface.

Thai character print mode

- Thai 3 pass
- Thai 1 pass (initial setting)

NOTE

Using Special Font A/B in Thai character 1-pass print mode is recommended.

Character code table default

Selectable from 43 pages including user defined page

Initial setting: Page 0 (PC437: USA, Standard Europe)

NOTE

For the character code table, see ["Character Code Tables" on page 91](#).

International character default

Selectable from 18 sets

Initial setting: USA

NOTE

For the character code table, see ["International Character Sets" on page 135](#).

Number of columns

- Standard mode (initial setting)
- 42 column mode

Autocutting after closing cover

- Cuts (initial setting)
- Does not cut

Font A auto replacement

- Does not replace (initial setting)
- Font B

Font B auto replacement

- Does not replace (initial setting)
- Font A

Optional buzzer

NOTE

- For information about how to connect the optional buzzer, see ["Connecting the Optional Buzzer Unit" on page 55](#).
- When the optional buzzer is set to "Enabled," a cash drawer cannot be used. Be sure to set it to "Disabled" when you use a cash drawer.

Enabled/disabled

- Enabled
- Disabled (initial setting)

Buzzer frequency (error)

- Does not sound
- Sounds 1 time
- Sounds continuously (initial setting)

Sound pattern (Autocut)

Selectable from Patterns A to E

Initial setting: Pattern A

Buzzer frequency (Autocut)

- Does not sound
- Sounds 1 time (initial setting)

Sound pattern (Pulse 1)

Selectable from Patterns A to E

Initial setting: Pattern A

Buzzer frequency (Pulse 1)

- Does not sound
- Sounds 1 time (initial setting)

Sound pattern (Pulse 2)

Selectable from Patterns A to E

Initial setting: Pattern B

Buzzer frequency (Pulse 2)

- Does not sound
- Sounds 1 time (initial setting)

Logo 180 dpi emulation mode

- Disabled (initial setting)
- Enabled



Enable the mode when you register graphics for 180 dpi so that the print result (203 dpi) is the same as one printed with a 180 dpi printer.

Communication condition of serial interface

Transmission speed

- 2400 bps
- 4800 bps
- 9600 bps
- 19200 bps
- 38400 bps (initial setting)
- 57600 bps
- 115200 bps

(bps: bits per second)

Parity

- None (initial setting)
- Even
- Odd

Data bit

- 7 bits
- 8 bits (initial setting)

CAUTION

If set to 7 bits, printing from a printer driver is not possible.

Flow control

- DTR/DSR (initial setting)
- XON/XOFF

Communication condition of USB interface

- USB printer class (initial setting)
- USB vendor-defined class

Auto top logo

Key-code

Selectable from key-codes of registered logos

Alignment

- Left
- Center
- Right

Auto bottom logo

Key-code

Selectable from key-codes of registered logos

Alignment

- Left
- Center
- Right

Top logo when printer is powered on

- Enabled
- Disabled (initial setting)

Top logo when cover is closed

- Enabled (initial setting)
- Disabled

Connecting the Optional Buzzer Unit

When the optional buzzer unit (model: OT-BZ20) is connected to the drawer kick-out connector of the printer, you can set the printer so that it beeps when you send commands, when an error occurs, and when the printer does specific operations such as autcutting. Settings for sound patterns and frequency depending on the occasions the buzzer beeps are also available.

You need to set the memory switches for buzzer enable/disable setting, sound pattern setting, and frequency setting. For information about the memory switches, see ["Setting the Memory Switches/Receipt Enhancement" on page 47](#).

CAUTION

- Be sure to turn off the printer before you connect/disconnect the buzzer unit.
- Do not connect both the optional buzzer unit and the cash drawer to the printer at the same time by using a branched connector.

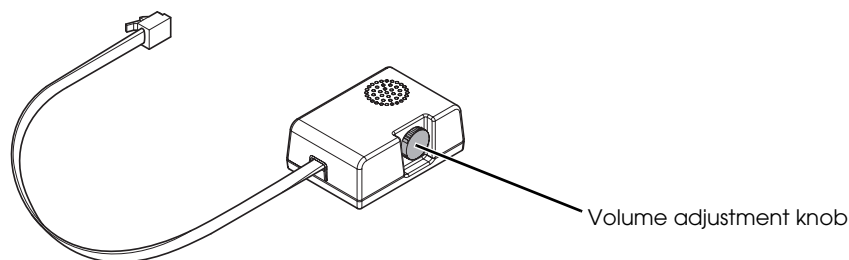

Connecting the Buzzer Unit

The buzzer unit is recommended to be installed in the following positions.

- When using the printer horizontally: either side
- When using the printer vertically or on the wall: either side/top/bottom (only for wall-hanging installation)

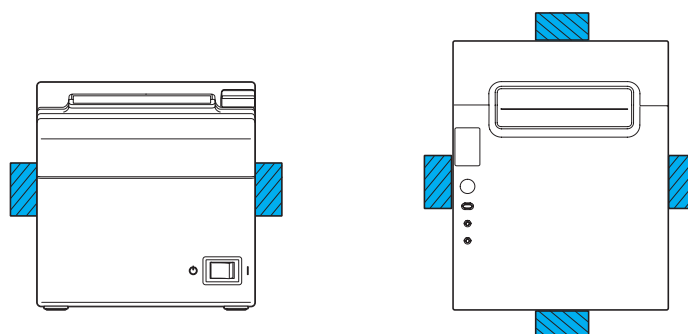

Horizontal installation

Vertical/Wall-hanging installation

CAUTION

- Do not install the optional buzzer unit at the roll paper exit.
- To prevent liquid from entering inside, it is recommended to install the buzzer unit so that the volume adjustment knob is positioned sideways or downward.

- 1** Turn off the printer.
- 2** Clean and dry the printer case where the buzzer unit will be installed.
- 3** With 2 included pieces of the affixing tape combined, peel off the backing paper on one side, and stick the tape in the center of the attaching surface of the buzzer unit.

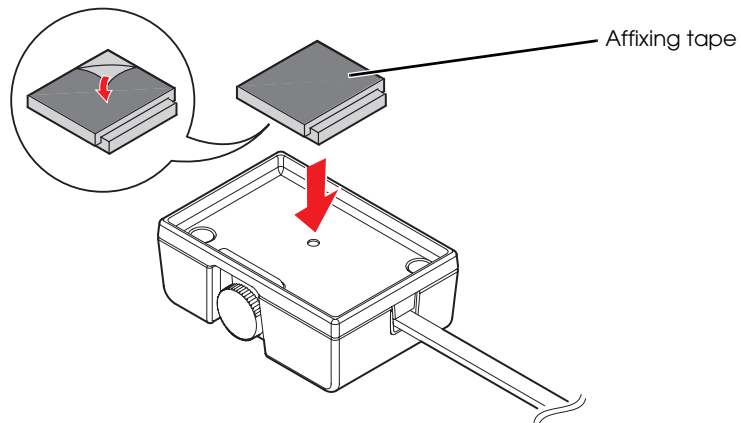

- 4** Connect the cable of the buzzer unit to the drawer kick-out connector on the printer.

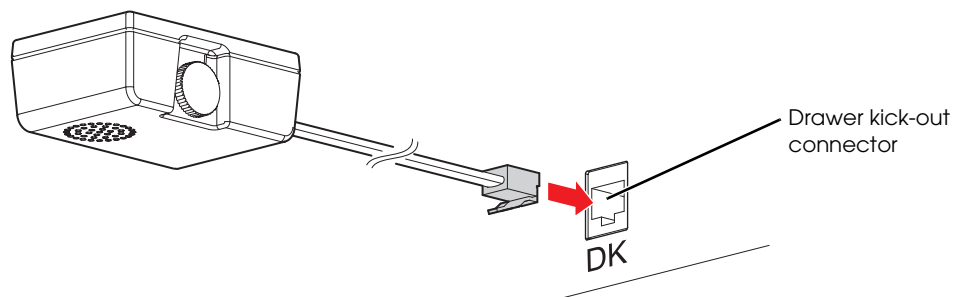

- 5** Peel off the backing paper on the other side of the affixing tape, and attach the buzzer unit to the printer case.

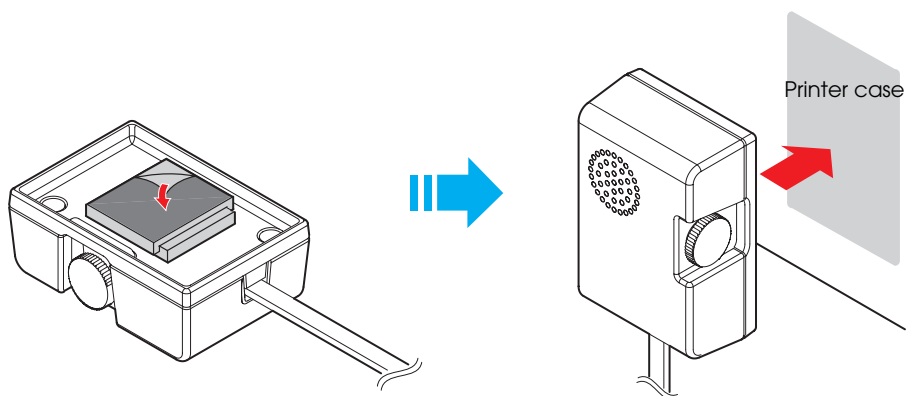

Connecting the Cash Drawer

Use a cash drawer handled by EPSON or your dealer.

CAUTION

- Do not connect both the optional external buzzer and the cash drawer to the printer at the same time by using a branched connector.
- When the optional buzzer is set to “Enabled” with the memory switch (see [“Setting the Memory Switches/Receipt Enhancement” on page 47](#)), a cash drawer cannot be used. Be sure to set it to “Disabled” when you use a cash drawer.

Connecting the Drawer Kick-out Cable

WARNING

- **Specifications of drawers differ depending on makers or models. When you use a drawer other than specified, make sure its specification meets the following conditions.**
Otherwise, devices may be damaged.
 - * The load, such as a drawer kick-out solenoid, must be connected between pins 4 and 2 or pins 4 and 5 of the drawer kick-out connector.
 - * When the drawer open/close signal is used, a switch must be provided between drawer kick-out connector pins 3 and 6.
 - * The resistance of the load, such as a drawer kick-out solenoid, must be $24\ \Omega$ or more or the input current must be 1A or less.
 - * Be sure to use the 24V power output on drawer-kick out connector pin 4 for driving the equipment.
- **Use a shield cable for the drawer connector cable.**
- **Two driver transistors cannot be energized simultaneously.**
- **Leave intervals longer than 4 times the drawer driving pulse when sending it continuously.**
- **Do not insert a telephone line into the drawer kick-out connector.**
Doing so may damage the telephone line or printer.

Connect the connector of the drawer kick-out cable to the printer.

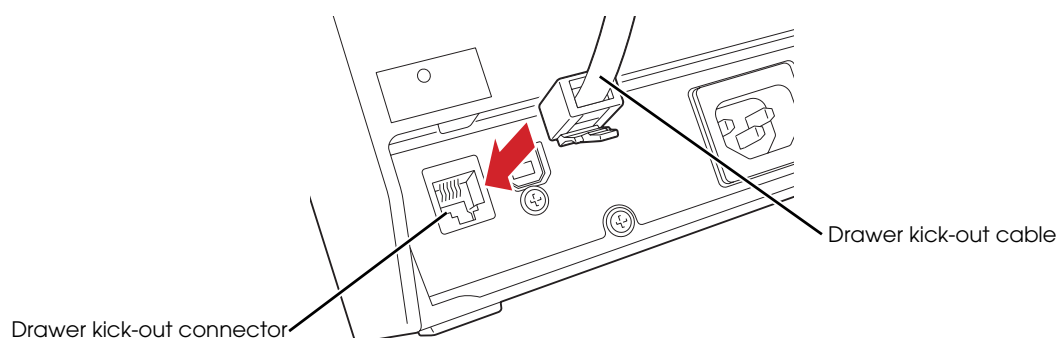

Drawer Connection Diagram

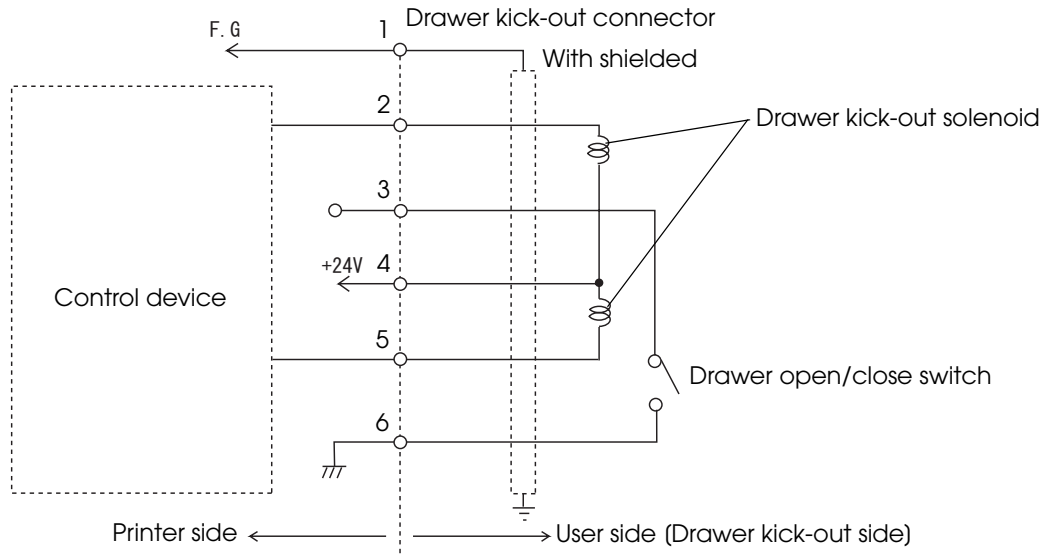

Application Development Information

This chapter describes how to control the printer and gives information useful for printer application development.

How to Control the Printer

Use a driver or ESC/POS commands to control the printer.

Selecting a Driver

Choose one of the drivers listed in ["Printer Drivers" on page 66](#), depending on the application operating environment. You cannot control a single printer with more than one driver.

For information about the driver operating environment, see the installation manual for each driver.

When you newly develop an application

- Use APD if you want to print TrueType fonts or print many graphics.
- OPOS ADK is recommended for system extensibility. An OPOS driver is provided for various peripherals and it is a POS industry standard now. It enables POS system efficiency, reduction of development cost, and effective use of application assets.

NOTE

You can use all functions, including ones not supported by OPOS ADK or APD, by using ESC/POS commands through your driver. Use the DIRECT I/O function of OPOS ADK, the control A command of APD, or Status API to send ESC/POS commands from each driver. (See ["ESC/POS command functions" on page 60](#).)

ESC/POS Commands

ESC/POS is the Epson original printer command system. With ESC/POS commands, you can directly control all the TM printer functions, but detailed knowledge of printer specifications or combination of commands is required, compared to using a driver.

To use ESC/POS commands, you need to agree to a nondisclosure contract first and obtain the ESC/POS Application Programming Guide. Ask your dealer for details.

The ESC/POS command functions are listed below. See the ESC/POS Application Programming Guide for more details.

ESC/POS command functions

Commands for printing
Print and line feed
Print and feed paper
Print and feed <i>n</i> lines
Print and return to standard mode (in page mode)
Print and carriage return
Print data in page mode
Select print mode(s)
Select the print speed
Turn double-strike mode on/off
Commands for line spacing
Set line spacing
Select default line spacing
Commands for print character
Select character code table
Select an international character set
Set right-side character spacing
Turn underline mode on/off
Turn emphasized mode on/off
Turn double-strike mode on/off
Select character font

Turn 90° clockwise rotation mode on/off
Select character size
Turn smoothing mode on/off
Turn upside-down print mode on/off
Turn white/black reverse print mode on/off
Select/cancel user-defined character set
Define user-defined characters
Cancel user-defined characters
Cancel print data in page mode
Commands for panel buttons
Enable/disable panel buttons
Commands for print positions
Horizontal tab
Set horizontal tab positions
Set left margin
Set print area width
Select justification
Set absolute print position
Set relative print position
Set print area in page mode
Select print direction in page mode
Set absolute vertical print position in page mode
Set relative vertical print position in page mode
Commands for bit image
Transmit the NV graphic memory capacity
Print the graphics data in the print buffer
Transmit the remaining capacity of the NV graphics memory
Transmit the remaining capacity of the downloaded NV graphics memory
Transmit the key code list for defined NV graphics
Delete all NV graphics data

Delete the specified NV graphics data
Define the NV graphics data (raster format)
Print the specified NV graphics data
Transmit the key code list for defined downloaded graphics
Delete all downloaded graphics data
Delete the specified downloaded graphics data
Define the downloaded graphics data (raster format)
Print the specified downloaded graphics data
Store the graphics data in the print buffer (raster format)
Select bit-image mode
Define downloaded bit image
Print downloaded bit image
Define Windows BMP NV graphics data
Define Windows BMP download graphics data
Commands for status
Enable/disable Automatic Status Back (ASB)
Transmit status
Transmit real-time status
Commands for barcode
Print barcode
Set barcode height
Set barcode width
Select print position of HRI characters
Select font for HRI characters
Commands for two-dimensional codes
PDF417: Set the number of columns in the data region
PDF417: Set the number of rows
PDF417: Set the width of module
PDF417: Set the row height
PDF417: Set the error correction level

PDF417: Select the options
PDF417: Store the data in the symbol storage area
PDF417: Print the symbol data in the symbol storage area
PDF417: Transmit the size information of the symbol data in the symbol storage area
QR Code: Select the model
QR Code: Set the size of module
QR Code: Select the error correction level
QR Code: Store the data in the symbol storage area
QR Code: Print the symbol data in the symbol storage data area
QR Code: Transmit the size information of the symbol data in the symbol storage area
MaxiCode: Select the mode
MaxiCode: Store the data in the symbol storage area
MaxiCode: Print the symbol data in the symbol storage area
MaxiCode: Transmit the size information of the symbol data in the symbol storage area
Two-dimensional GS1 DataBar: Set the width of module
Two-dimensional GS1 DataBar: Set the maximum width of GS1 DataBar Expanded Stacked
Two-dimensional GS1 DataBar: Store the data in the symbol storage area
Two-dimensional GS1 DataBar: Print the symbol data in the symbol storage area
Two-dimensional GS1 DataBar: Transmit the size information of the symbol data in the symbol storage area
Composite Symbology: Set the width of module
Composite Symbology: Set the maximum width of GS1 DataBar Expanded Stacked
Composite Symbology: Select font for HRI characters
Composite Symbology: Store the data in the symbol storage area
Composite Symbology: Print the symbol data in the symbol storage area
Composite Symbology: Transmit the size information of the symbol data in the symbol storage area
Commands for mechanical control
Select cut mode and cut paper
Commands for customization
Change into the user setting mode

End the user setting mode session
Set values for the memory switch
Transmit the setting of the memory switch
Set the customized setting values
Transmit the customized setting values
Set conditions for USB interface communication
Transmit conditions for USB interface communication
Set conditions for serial interface communication
Transmit conditions for serial interface communication
Write to NV user memory
Read from NV user memory
Commands for sub-functions
Initialize printer
Transmit printer ID
Set horizontal and vertical motion units
Select peripheral device
Generate pulse
Generate pulse in real-time
Execute power-off sequence
Control buzzer (optional external buzzer)
Clear buffer(s)
Enable/disable real-time command
Send real-time request to printer
Select page mode
Select standard mode
Set the process ID response
Execute test print
Select the print speed
Start/end macro definition
Execute macro

Initialize maintenance counter
Transmit maintenance counter
Commands for receipt enhancement
Cancel set values for top/bottom logo printing
Transmit set values for top/bottom logo printing
Set top logo printing
Set bottom logo printing
Make extended settings for top/bottom logo printing
Enable/disable top/bottom logo printing
Commands for Kanji (only for Simplified Chinese models)
Select print mode(s) for Kanji characters
Select Kanji character mode
Turn underline mode on/off for Kanji characters
Cancel Kanji character mode
Define user-defined Kanji characters
Select Kanji character code system
Set Kanji character spacing
Turn quadruple-size mode on/off for Kanji characters

Software and Manuals

The following software and manuals are provided for application development.

Printer Drivers

Software	Manual
<p>EPSON Advanced Printer Driver (APD):</p> <p>In addition to ordinary Windows driver functions, this driver has controls specific to POS, such as controls for paper cut, a cash drawer, and customer display. The Status API (Epson original DLL) that monitors printer status and sends ESC/POS commands is also attached to this driver.</p>	<ul style="list-style-type: none"> • APD Install Manual • APD TM/BA/EU Printer Manual • APD Printer Specification • Status API Manual • Devmode API/PRINTERINFO Manual • Sample Program Guide • TM-T82 Software User's Manual
<p>EPSON OPOS ADK:</p> <p>This OCX driver can control POS peripherals using OLE technology*¹. Because controlling POS peripherals with original commands is not required on the application side, efficient system development is possible.</p>	<ul style="list-style-type: none"> • OPOS Installation Manual • User's Manual • Application Development Guide • UnifiedPOS Retail Peripheral Architecture*² • Sample Program Guide
<p>EPSON OPOS ADK for .NET:</p> <p>OPOS ADK for .NET allows you to develop applications that are compatible with Microsoft POS for .NET.</p> <p>When developing applications, use a separate development environment such as Microsoft Visual Studio .NET.</p>	<ul style="list-style-type: none"> • OPOS ADK for .NET Installation Guide • User's Reference (SetupPOS) • Application Development Guide (POSPrinter TM-T82) • UnifiedPOS Retail Peripheral Architecture*²
<p>EPSON JavaPOS ADK:</p> <p>JavaPOS is the standard specification which defines an architecture and device interface (API) to access various POS devices from a Java based system. Using JavaPOS standard API allows control with Java-based applications of functions inherent to each device. A flexible design with Java language and JavaPOS enables many different types of computer systems, such as stand alone or network configuration, to use a same application. You can use JavaPOS to build applications and drivers independently of platforms. This allows flexible configurations using thin clients to meet the system requirements.</p>	<p>JavaPOS ADK Installation Guide</p>

Software	Manual
<p>EPSON TM Virtual Port Driver:</p> <p>This driver is a Serial-USB/Ethernet and Parallel-USB/Ethernet conversion driver to make an EPSON TM/BA/EU printer connected via USB/Ethernet accessible from a POS application through virtual COM ports and a virtual LPT port. Without making changes in the POS application that controls devices connected through serial or parallel interfaces, devices connected via USB/Ethernet can be directly controlled with ESC/POS commands.</p>	<p>TM Virtual Port Driver User's Manual</p>
<p>TM-T82 Mac Printer Driver:</p> <p>Mac printer driver allows you to control the TM-T82 using Common UNIX Printing System (CUPS) on Mac OS X.</p> <p>This is a full raster printer driver. It is able to print images, text, and vector graphics etc., that an application displays. With this driver many printer controls are possible, such as paper cut timing control, cash drawer control, printing speed control, blank line skip, and upside-down printing. It also provides API and dialogues for print setting, sample applications, and logo setting utility.</p>	<p>TM-T82 Mac Printer Driver User's Manual</p>
<p>Epson TM/BA Series Thermal Printer Driver:</p> <p>This driver allows you to control the TM-T82 using Common UNIX Printing System (CUPS) on GNU/Linux.</p> <p>This is a full raster printer driver. It is able to print images, text, and vector graphics etc., that an application displays. With this driver many printer control are possible, such as paper cut timing control, cash drawer control, printing speed control, blank line skip, and upside-down printing.</p>	<ul style="list-style-type: none"> • Epson TM/BA Series Thermal Printer Driver Installation Manual • Epson TM/BA Series Thermal Printer Driver Manual • TM-T82 Thermal Printer Driver Manual

*1: OLE technology developed by Microsoft divides software into part blocks. The OPOS driver is presupposed to be used with a development environment such as Visual Basic, unlike ordinary Windows drivers. It is not a driver to be used for printing from commercial applications.

*2: This guide describes general information on how to control printers using the OPOS ADK (in the chapter "POS Printer" and "Appendix-A"). It does not describe Epson's specific functions.

Utilities

Software	Manual
<p>TM-T82 Utility: Use for the following functions:</p> <ul style="list-style-type: none"> • Checking current settings • Operation check • Storing logos • Automatic paper cut settings • Printing control settings • Font settings • Optional buzzer settings • Communication I/F settings • Backup/restore 	<ul style="list-style-type: none"> • TM-T82 Software User's Manual • TM-T82 Utility User's Manual
<p>EPSON TM Net WinConfig: Use for IP address setting.</p>	<ul style="list-style-type: none"> • TM Net WinConfig User's Guide • UB-E03 Technical Reference Guide*
<p>EpsonNet Simple Viewer: Use for checking the status of EPSON printers connected to a network and EPSON TM/BA printers connected to computers on a network.</p>	<p>EpsonNet Simple Viewer User's Manual</p>
<p>TM/BA/EU Printer Remote Configuration Tool: This is a package of EpsonNet Simple Viewer and TM-T82 Utility. First install this software in the computer with the administrator's authority, and set up the firewall. Next, install the printer driver in each client computer and set up the firewall. Then you can check the status of and configure the printer connected to a client computer on the network from the computer with the administrator's authority.</p>	<p>TM / BA /EU Printer Remote Configuration Tool User's Manual</p>

*: See the following sections in Chapter 2;

- * Setting IP Address Using EPSON TMNet WinConfig
- * Setting IP Address Using arp/ping Command
- * Checking/Changing the Settings
- * Initializing
- * ESPON TMNet WebConfig

How to Get Drivers, Manuals, and the Utility

Drivers, manuals, and the TM-T82 Utility can be installed by the TM-T82 installer in the included TM-T82 Software & Documents Disc.

You can also obtain them from the following URL.

<http://www.epson-pos.com/>

Setting/Checking Modes

Besides the ordinary print mode, the printer has the following modes to set or check settings of the printer.

- Self-test Mode
- Hexadecimal Dumping Mode ([page 72](#))
- NV Graphics Information Print Mode ([page 73](#))
- Receipt Enhancement Information Print Mode ([page 75](#))
- Memory Switch Setting Mode ([page 76](#))

Self-test Mode

In the self-test mode, the printer prints the current printer status and a rolling pattern test print of resident characters.

The current status print includes the following information:

- Control ROM version
- Interface type
- Receive buffer size
- BUSY condition
- Mounted multilingual fonts
- Print density
- Maintenance counter information (head running length, number of times of autocutting)
- Memory switch settings

Starting the self-test mode

Follow the steps below to run this mode.

- 1** Close the roll paper cover.
- 2** While pressing the Feed button, turn on the printer. (Keep pressing the Feed button until the printer starts printing.)
The printer starts printing current status of the printer.

NOTE

With the Ethernet interface, before printing starts, it takes 15 seconds if the IP address is fixed and 20 seconds if the IP address is obtained with the automatic setting. (It may take longer, depending on the response time from the host.)

When the printer finishes printing the printer status, the following message is printed and the Paper LED flashes. (The printer is now in the self-test wait mode.):

“Select Modes by pressing Feed button.

Continue SELF-TEST: Less than 1 second

Mode Selection: 1 second or more”

- 3** Press the Feed button to start the test print (less than 1 second).
The printer starts test printing. (A rolling pattern is printed using only the resident character set.)

NOTE

If you select “Mode Selection,” the printer goes to ["NV Graphics Information Print Mode" \(page 73\)](#), ["Receipt Enhancement Information Print Mode" \(page 75\)](#), or ["Memory Switch Setting Mode" \(page 76\)](#).

After the test printing has finished, the printer prints the following message, and then the printer is initialized and returned to the normal mode.

“*** completed***”

Hexadecimal Dumping Mode

In the hexadecimal dumping mode, the printer prints the data transmitted from a host computer in hexadecimal numbers and their corresponding characters. It enables you to check if data is transmitted to the printer correctly.

Starting the hexadecimal dumping mode

Follow the steps below to run this mode.

CAUTION

- If there is no character corresponding to print data, "." is printed.
- If print data is less than one line, press the Feed button to print the line.
- Applications that confirm printer status may not work correctly during the hexadecimal dumping mode. The printer returns only the status for "Transmit real-time status."

- 1** Open the roll paper cover.
- 2** While pressing the Feed button, turn on the printer.
- 3** Close the roll paper cover.
The printer starts printing data received from then on in hexadecimal numbers and their corresponding characters.

Turn off the printer or press the Feed button three times to return to the normal mode.

Printing example:

```
Hexadecimal Dump
To terminate hexadecimal dump,
press FEED button three times.

1B 21 00 1B 26 02 40 40 1B 69 . ! . . & . @ . i
1B 25 01 1B 63 34 00 1B 30 31 . % . . c 4 . . 0 1
41 42 43 44 45 46 47 48 49 4A A B C D E F G H I J

*** completed ***
```

NV Graphics Information Print Mode

You can confirm the following information by running the NV graphics information print mode:

- Capacity of the NV graphics
- Used capacity of the NV graphics
- Unused capacity of the NV graphics
- Number of NV graphics that are registered
- Key code, number of dots in X direction, number of dots in Y direction, number of colors to be defined.
- NV graphics data

Starting the NV graphics information print mode

Follow the steps below to run this mode.

- 1 Close the roll paper cover.
- 2 While pressing the Feed button, turn on the printer. (Keep pressing the Feed button until the printer starts printing.)
The printer starts printing current status of the printer.

NOTE

With the Ethernet interface, before printing starts, it takes 15 seconds if the IP address is fixed and 20 seconds if the IP address is obtained with the automatic setting. (It may take longer, depending on the response time from the host.)

When the printer finishes printing the printer status, the following message is printed and the Paper LED flashes. (The printer is now in the self-test wait mode.):

“Select Modes by pressing Feed button.

Continue SELF-TEST: Less than 1 second

Mode Selection: 1 second or more”

- 3 Press the Feed button. (Keep pressing the Feed button until the printer starts printing.)
The printer starts printing instructions.
- 4 Press the Feed button once.

-
- 5** Then press the Feed button. (Keep pressing the Feed button until the printer starts printing.)

The printer starts printing the NV graphics information.

Turn the power off and on to return to the normal mode.

Receipt Enhancement Information Print Mode

You can confirm the following information by running the R/E information mode:

- Automatic top logo setting
- Automatic bottom logo setting
- Extended settings for automatic top/bottom logo

Starting the R/E information print mode

Follow the steps below to run this mode.

- 1 Close the roll paper cover.
- 2 While pressing the Feed button, turn on the printer. (Keep pressing the Feed button until the printer starts printing.)
The printer starts printing current status of the printer.

NOTE

With the Ethernet interface, before printing starts, it takes 15 seconds if the IP address is fixed and 20 seconds if the IP address is obtained with the automatic setting. (It may take longer, depending on the response time from the host.)

When the printer finishes printing the printer status, the following message is printed and the Paper LED flashes. (The printer is now in the self-test wait mode.):

“Select Modes by pressing Feed button.

Continue SELF-TEST: Less than 1 second

Mode Selection: 1 second or more”

- 3 Press the Feed button. (Keep pressing the Feed button until the printer starts printing.)
The printer starts printing instructions.
- 4 Press the Feed button twice.
- 5 Then press the Feed button. (Keep pressing the Feed button until the printer starts printing.)
The printer starts printing the R/E information.

Turn the power off and on to return to the normal mode.

Memory Switch Setting Mode

In the memory switch setting mode, you can set the following memory switches.

- Receive buffer capacity
- Processing when data receive error
- USB power-saving function
- Roll paper width
- Print speed
- Character code table default
- Number of columns
- Near-end detection
- Font replacement
- Communication condition of USB interface
- BUSY condition
- Auto line feed
- Release condition of receive buffer BUSY
- Print density
- Thai character print mode*
- International character default
- Autocutting after closing cover
- Logo emulation
- Optional buzzer
- Communication condition of serial interface

*: Only for the South Asia models

Starting the memory switch setting mode

Follow the steps below to run this mode.

- 1** Close the roll paper cover.
- 2** While pressing the Feed button, turn on the printer. (Keep pressing the Feed button until the printer starts printing.)
The printer starts printing current status of the printer.

NOTE

With the Ethernet interface, before printing starts, it takes 15 seconds if the IP address is fixed and 20 seconds if the IP address is obtained with the automatic setting. (It may take longer, depending on the response time from the host.)

When the printer finishes printing the printer status, the following message is printed and the Paper LED flashes. (The printer is now in the self-test wait mode.):

“Select Modes by pressing Feed button.

Continue SELF-TEST: Less than 1 second

Mode Selection: 1 second or more”

- 3** Press the Feed button. (Keep pressing the Feed button until the printer starts printing.)
The printer starts printing instructions.
- 4** Press the Feed button three times.
- 5** Then press the Feed button. (Keep pressing the Feed button until the printer starts printing.)
The printer starts printing instructions for settings. Follow the instructions.

After one setting has been completed, the printer stores the setting and then starts initializing. After that, the printer returns to the normal mode.



Handling

This chapter describes basic handling of the printer.

Installing and Replacing Roll Paper



- **Do not open the roll paper cover during printing or autocutting.**
The printer may be damaged.
- **Do not touch the manual cutter with your hands when installing or replacing the roll paper.**
Otherwise, you may be injured because the manual cutter blade is sharp.

CAUTION

- Use roll paper that meets the printer specification. For details about paper specification, see "Paper Specifications" on page 27.
- Paper must not be pasted to the roll paper spool.

- 1** Press the cover open lever to open the roll paper cover.

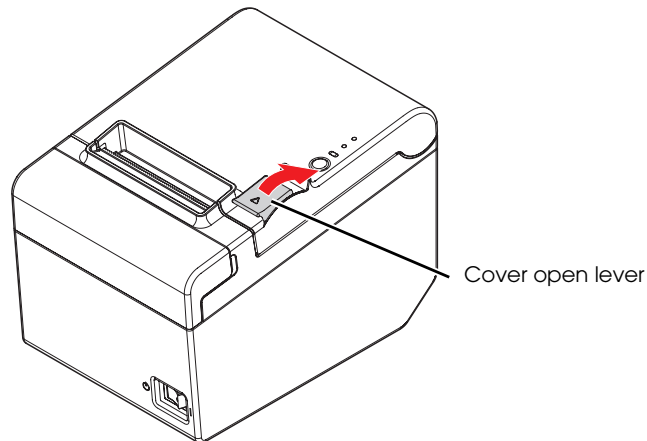

- 2** Remove the used roll paper core, if any.

- 3** Install the roll paper in the correct direction.

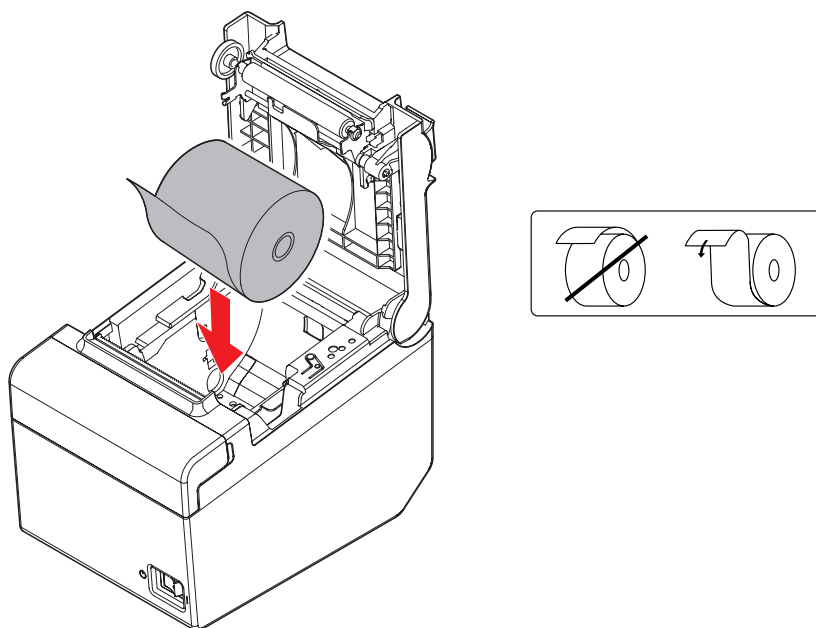

- 4** Pull out some roll paper, and close the roll paper cover.
When the printer power is on, the roll paper is automatically cut. (initial setting)

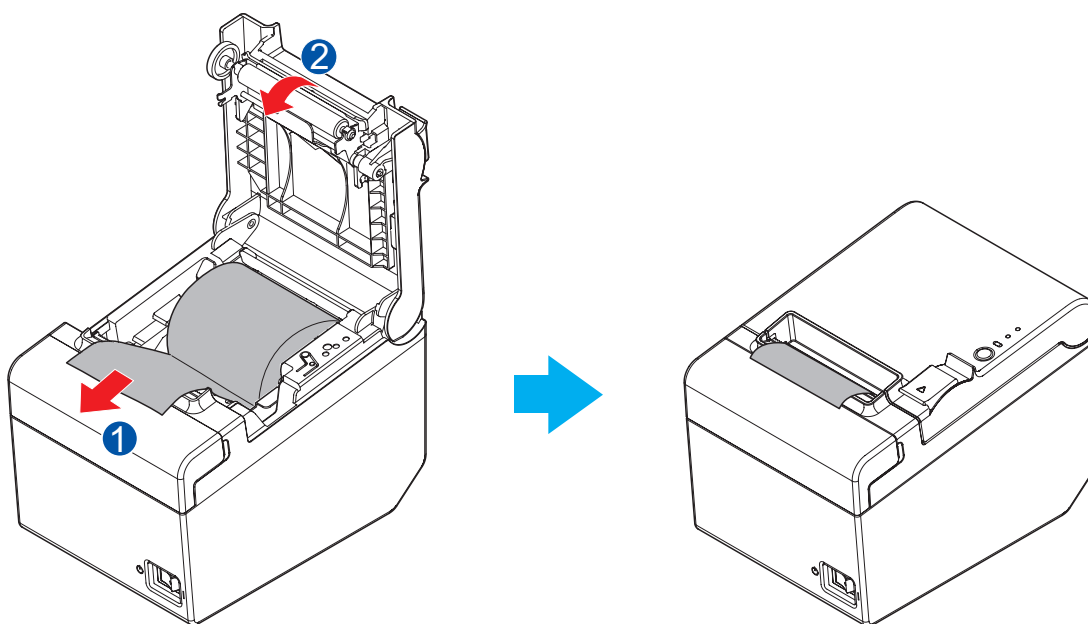

Removing Jammed Paper

When a paper jam occurs, never pull out the paper forcibly. Turn off the printer power, open the roll paper cover, and then remove the jammed paper.



Do not touch the thermal head. (See "Cleaning the Printer" on page 83.)
It can be very hot after printing.

When the Roll Paper Cover Cannot be Opened

When the roll paper cover cannot be opened due to jammed paper, follow the steps below to open it.

- 1 Turn off the printer.
- 2 Slide the cutter cover toward the front to open it.

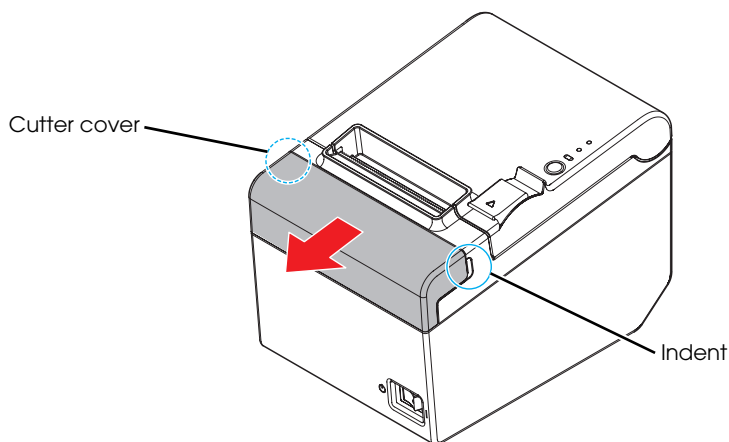

-
- 3** Turn the knob until you see a triangle in the opening.
This returns the cutter blade to the normal position.

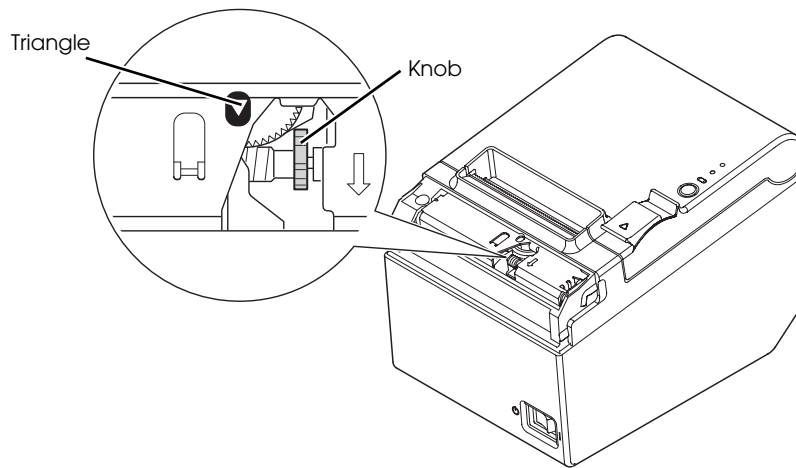

- 4** Install the cutter cover.

Cleaning the Printer

Cleaning the Printer Case

Be sure to turn off the printer, and wipe the dirt off the printer case with a dry cloth or a damp cloth.



Never clean the product with alcohol, benzine, thinner, or other such solvents. Doing so may damage or break the parts made of plastic and rubber.

Cleaning the Thermal Head/Platen Roller

Epson recommends cleaning the thermal head periodically (generally every 3 months) to maintain receipt print quality.

Depending on the roll paper used, paper dust may stick to the platen roller and the paper may not be fed correctly. To remove the paper dust, clean the platen roller.

Turn off the printer, open the roll paper cover, and clean the thermal elements of the thermal head/platen roller with a cotton swab moistened with an alcohol solvent (ethanol or IPA).



- After printing, the thermal head can be very hot. Do not touch it and let it cool before you clean it.
- Do not damage the thermal head by touching it with your fingers or any hard object.

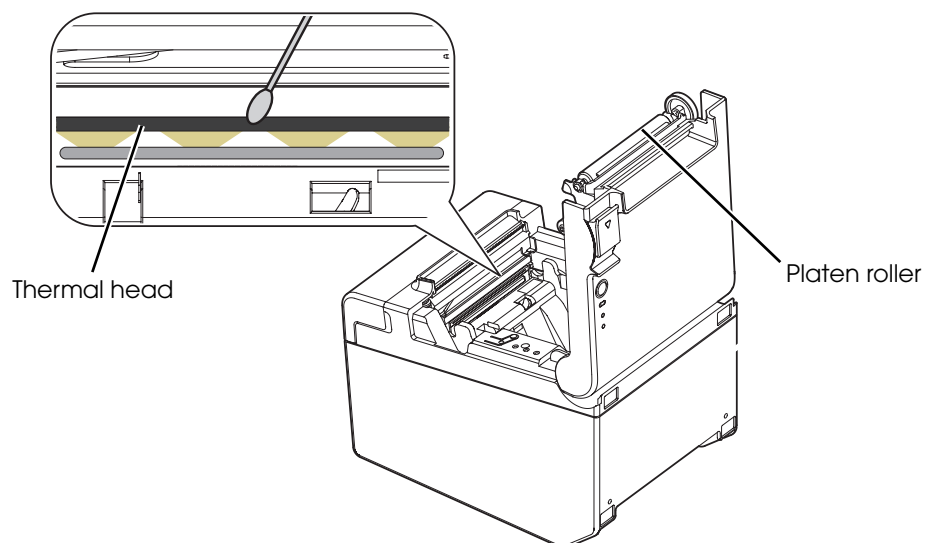

Preparing for Transport

Follow the steps below to transport the printer.

- 1** Turn off the printer.
- 2** Disconnect the AC cable from the socket.
- 3** Remove the roll paper.
- 4** Pack the printer upright.

Appendix

Specifications of Interface and Connector

USB (Universal Serial Bus) Interface

Outline

- Full-speed transmission at 12 Mbps [bps: bits per second]
- Plug & Play, Hot Insertion & Removal

USB transmission specifications

USB function

Overall specifications	According to USB 2.0 specifications	
Transmission speed	USB Full-Speed (12 Mbps)	
Transmission method	USB bulk transmission method	
Power supply specifications	USB self power supply function	
Current consumed by USB bus	0 mA	
USB packet size (with full-speed connection)	USB bulk OUT	64 bytes
	USB bulk IN	64 bytes

Status transmission from printer with USB interface

In order to ensure that there is no lack of status data, it is necessary to periodically retrieve status data at the host computer.

However, it cannot spontaneously interrupt data transmission to the host computer.

The printer has a 128-byte status data buffer. Statuses that exceed the buffer capacity are canceled.

RS-232 Serial Interface

Interface board specifications (RS-232-compliant)

Item		Specifications
Data transfer method		Serial
Synchronization		Asynchronous
Handshake		Select one of the following with the memory switch <ul style="list-style-type: none"> • DTR/DSR • XON/XOFF
Signal level	MARK	-3V to -15V logic "1"/OFF
	SPACE	+3V to +15V logic "0"/ON
Bit length		Select one of the following with the memory switch <ul style="list-style-type: none"> • 7 bit • 8 bit
Transmission speed		Select one of the following with the memory switch: 2400/4800/9600/19200/38400/57600/115200 bps (bps: bits per second)
Parity check		Select one of the following with the memory switch: <ul style="list-style-type: none"> • Yes • No
Parity selection		Select one of the following with the memory switch: <ul style="list-style-type: none"> • Even • Odd
Stop bit		1 or more bits However, the stop bit for data transfer from the printer is fixed to 1 bit.
Connector	Printer side	DSUB 9-pin (female) connector

Functions of each connector pin

Pin no.	Signal name	Signal direction	Function
2	RXD	Input	Reception data
3	TXD	Output	Transmission data
4	DTR	Output	<p>1) When DTR/DSR control is selected, this signal indicates whether the printer is BUSY.</p> <ul style="list-style-type: none"> • SPACE status Indicates that the printer is ready to receive data. • MARK status Indicates that the printer is BUSY. Set BUSY conditions with the memory switch. <p>2) When XON/XOFF control is selected, the signal indicates that the printer is properly connected and ready to receive data from the host. The signal is always SPACE, except in the following cases:</p> <ul style="list-style-type: none"> • During the period from when power is turned on to when the printer is ready to receive data. • During the self-test.
5	SG	—	Signal ground
6	DSR	Input	<p>This signal indicates whether the host computer can receive data.</p> <p>SPACE indicates that the host computer can receive data. MARK indicates that the host computer cannot receive data.</p> <p>When DTR/DSR control is selected, the printer transmits data after confirming this signal (except if transmitted using some ESC/POS commands).</p> <p>When XON/XOFF control is selected, the printer does not check this signal.</p>
7	RTS	Output	Equivalent to DTR signal (pin 4)

XON/XOFF

When XON/XOFF control is selected, the printer transmits the XON or XOFF signals as follows. The transmission timing of XON/XOFF differs, depending on the setting of memory switch 1-3.

Signal	Printer status	Memory switch 1-3	
		1 (ON)	0 (OFF)
XON	1) When the printer goes online after turning on the power	Transmit	Transmit
	2) When the receive buffer is released from the buffer full state	Transmit	Transmit
	3) When the printer switches from offline to online	—	Transmit
	4) When the printer recovers from an error using some ESC/POS commands	—	Transmit
XOFF	5) When the receive buffer becomes full	Transmit	Transmit
	6) When the printer switches from online to offline	—	Transmit

Code

The hexadecimal numbers corresponding to the XON/XOFF codes are shown below.

- XON code: 11H
- XOFF code: 13H

CAUTION

- When the printer goes from offline to online and the receive buffer is full, XON is not transmitted.
- When the printer goes from online to offline and the receive buffer is full, XOFF is not transmitted.

10BASE-T/100BASE-TX Ethernet Interface

Software specifications

Basic communication protocols

- IP, ARP, ICMP, UDP, TCP: Basic communications protocols for various functions (used by higher-level protocols below)

Printing communications protocols

- LP, LPR: Transfers printing data.
- TCP socket port: Transfers printing data and printer status with direct socket communications (bi-directional).

Protocol for obtaining status and setting

- HTTP: Displays module status and makes setting with the Web browser.
- SNMP: Obtains status and/or sets the module or printer with the dedicated/commercial MIB tool.
- ENPC: Obtains status and/or sets for the module and printer.

Automatic IP Address Assignment Protocols

Automatic IP addressing is executed in order shown in the table below. If DHCP is disabled or IP addressing for DHCP fails, then IP addressing for the next protocols is executed. If APIPA is disabled or IP address cannot be obtained, the internal setting parameters are used.

Protocol	Order	Application
DHCP	1	Obtains IP address.
APIPA	2	Assigns IP address.
Manual setting	3	Uses the internal parameters.

Internal parameter settings

Internal parameter settings can be changed with the following:

- ENPC protocol: Epson provides a dedicated utility that makes miscellaneous setting with the ENPC protocol.
- HTTP browser: An HTTP browser can make setting when connected to the module.
- arp commands and ping commands (Only IP address is settable.):
This function is available only when it has been enabled. The setting can be

made only from a host PC that supports both arp and ping commands and is in the same segment as the module.

Article	Parameters	Default values	Utility		Browser		Status sheet print
			View	Setting	View	Setting	
IP address		192.168.192.168	Yes	Yes	Yes	Yes	Yes
Subnet mask		255.255.255.0	Yes	Yes	Yes	Yes	Yes
Gateway address		0.0.0.0	Yes	Yes	Yes	Yes	Yes
DHCP	Enable/Disable	Disable	Yes	Yes	Yes	Yes	Yes
APIPA	Enable/Disable	Disable	Yes	Yes	Yes	Yes	Yes
Arp/ping IP setting	Enable/Disable	Enable	Yes	Yes	Yes	Yes	No
Community name 1 (read-only)	Max. 16 characters	"public"	Yes	No	Yes	No	Yes
Community name 2 (read-write)	Max. 16 characters	None	Yes	Yes	Yes	Yes	Yes
IP Trap 1 Enable	Enable/Disable	Disable	Yes	Yes	Yes	Yes	No
IP Trap 2 Enable	Enable/Disable	Disable	Yes	Yes	Yes	Yes	No
Community name (IP Trap #1)	Max. 16 characters	None	Yes	Yes	Yes	Yes	No
Community name (IP Trap #2)	Max. 16 characters	None	Yes	Yes	Yes	Yes	No
IP trap #1 address		None	Yes	Yes	Yes	Yes	No
IP trap #2 address		None	Yes	Yes	Yes	Yes	No
Socket timeout	0: No timeout 1-300: duration of timeout (seconds)	300	No	No	Yes	Yes	Yes
Password		None	No	Yes	No	Yes	No
Mode name	Auto negotiation /10Base-T Half /10Base-T Full /100Base-TX Half /100Base-TX Full	Auto negotiation	Yes	Yes	Yes	Yes	Yes
Hardware version	—	—	Yes	No	Yes	No	Yes
Firmware version	—	—	Yes	No	Yes	No	Yes
MAC address	—	—	Yes	No	Yes	No	Yes

Character Code Tables

CAUTION

- The character code tables show only character configurations. They do not show the actual print pattern.
- "SP" in the table shows a space.

Common to All Pages

When International character set (See ["International Character Sets" on page 135.](#)) is USA:

HEX	0	1	2	3	4	5	6	7
0	NUL 0	DLE 16	SP 32	0 48	@ 64	P 80	` 96	p 112
1		XON 17	! 33	1 49	A 65	Q 81	a 97	q 113
2			" 34	2 50	B 66	R 82	b 98	r 114
3		XOFF 19	# 35	3 51	C 67	S 83	c 99	s 115
4	EOT 4	DC4 20	\$ 36	4 52	D 68	T 84	d 100	t 116
5	ENQ 5	NAK 21	% 37	5 53	E 69	U 85	e 101	u 117
6	ACK 6		& 38	6 54	F 70	V 86	f 102	v 118
7			' 39	7 55	G 71	W 87	g 103	w 119
8		CAN 24	(40	8 56	H 72	X 88	h 104	x 120
9	HT 9) 41	9 57	I 73	Y 89	i 105	y 121
A	LF 10		* 42	: 58	J 74	Z 90	j 106	z 122
B		ESC 27	+ 43	; 59	K 75	[91	k 107	{ 123
C	FF 12	FS 28	, 44	< 60	L 76	\ 92	l 108	 124
D	CR 13	GS 29	- 45	= 61	M 77] 93	m 109	} 125
E		RS 30	· 46	> 62	N 78	^ 94	n 110	~ 126
F			/ 47	? 63	O 79	_ 95	o 111	SP 127

HEX	8	9	A	B	C	D	E	F
0	Ç <small>128</small>	É <small>144</small>	á <small>160</small>	☼ <small>176</small>	Ł <small>192</small>	⋈ <small>208</small>	ɑ <small>224</small>	≡ <small>240</small>
1	Ü <small>129</small>	æ <small>145</small>	í <small>161</small>	☼ <small>177</small>	⊥ <small>193</small>	⌣ <small>209</small>	β <small>225</small>	± <small>241</small>
2	é <small>130</small>	Æ <small>146</small>	ó <small>162</small>	☼ <small>178</small>	τ <small>194</small>	π <small>210</small>	Γ <small>226</small>	≥ <small>242</small>
3	â <small>131</small>	ô <small>147</small>	ú <small>163</small>	∣ <small>179</small>	† <small>195</small>	⋈ <small>211</small>	π <small>227</small>	≤ <small>243</small>
4	ä <small>132</small>	ö <small>148</small>	ñ <small>164</small>	‡ <small>180</small>	– <small>196</small>	⌣ <small>212</small>	Σ <small>228</small>	∫ <small>244</small>
5	à <small>133</small>	ò <small>149</small>	Ñ <small>165</small>	‡ <small>181</small>	† <small>197</small>	ƒ <small>213</small>	σ <small>229</small>	∫ <small>245</small>
6	å <small>134</small>	û <small>150</small>	ä <small>166</small>	∥ <small>182</small>	‡ <small>198</small>	π <small>214</small>	μ <small>230</small>	÷ <small>246</small>
7	ç <small>135</small>	ù <small>151</small>	º <small>167</small>	π <small>183</small>	∥ <small>199</small>	‡ <small>215</small>	τ <small>231</small>	≈ <small>247</small>
8	ê <small>136</small>	ÿ <small>152</small>	¿ <small>168</small>	‡ <small>184</small>	⋈ <small>200</small>	‡ <small>216</small>	φ <small>232</small>	° <small>248</small>
9	ë <small>137</small>	ö <small>153</small>	ƒ <small>169</small>	∥ <small>185</small>	∥ <small>201</small>	∫ <small>217</small>	θ <small>233</small>	• <small>249</small>
A	è <small>138</small>	ü <small>154</small>	ƒ <small>170</small>	∥ <small>186</small>	⋈ <small>202</small>	∫ <small>218</small>	Ω <small>234</small>	• <small>250</small>
B	ï <small>139</small>	ϕ <small>155</small>	½ <small>171</small>	π <small>187</small>	⌣ <small>203</small>	■ <small>219</small>	δ <small>235</small>	√ <small>251</small>
C	î <small>140</small>	£ <small>156</small>	¼ <small>172</small>	∥ <small>188</small>	∥ <small>204</small>	■ <small>220</small>	ω <small>236</small>	n <small>252</small>
D	ì <small>141</small>	¥ <small>157</small>	ı <small>173</small>	⋈ <small>189</small>	= <small>205</small>	∣ <small>221</small>	φ <small>237</small>	² <small>253</small>
E	Ä <small>142</small>	℥ <small>158</small>	« <small>174</small>	∫ <small>190</small>	‡ <small>206</small>	∣ <small>222</small>	ε <small>238</small>	■ <small>254</small>
F	Å <small>143</small>	ƒ <small>159</small>	» <small>175</small>	∫ <small>191</small>	⋈ <small>207</small>	■ <small>223</small>	∩ <small>239</small>	SP <small>255</small>

Page 1 (Katakana)

HEX	8	9	A	B	C	D	E	F
0	— 128	⊥ 144	SP 160	— 176	タ 192	ミ 208	ニ 224	× 240
1	— 129	⊥ 145	。 161	ア 177	チ 193	ム 209	ト 225	円 241
2	■ 130	⊥ 146	「 162	イ 178	ツ 194	メ 210	キ 226	年 242
3	■ 131	⊥ 147	」 163	ウ 179	テ 195	モ 211	ト 227	月 243
4	■ 132	— 148	、 164	エ 180	ト 196	ヤ 212	▲ 228	日 244
5	■ 133	— 149	・ 165	オ 181	ナ 197	ユ 213	▲ 229	時 245
6	■ 134	150	ヲ 166	カ 182	ニ 198	ヨ 214	▼ 230	分 246
7	■ 135	151	ア 167	キ 183	ヌ 199	ラ 215	▼ 231	秒 247
8	136	「 152	イ 168	ク 184	ネ 200	リ 216	♠ 232	〒 248
9	137	「 153	ウ 169	ケ 185	ノ 201	ル 217	♥ 233	市 249
A	138	「 154	エ 170	コ 186	ハ 202	レ 218	♦ 234	区 250
B	139	」 155	オ 171	サ 187	ヒ 203	ロ 219	♣ 235	町 251
C	■ 140	「 156	ヤ 172	シ 188	フ 204	ワ 220	● 236	村 252
D	■ 141	「 157	ユ 173	ス 189	ヘ 205	ソ 221	○ 237	人 253
E	■ 142	「 158	ヨ 174	セ 190	ホ 206	“ 222	/ 238	☼ 254
F	⊥ 143	」 159	ツ 175	リ 191	マ 207	° 223	∖ 239	SP 255

HEX	8	9	A	B	C	D	E	F
0	Ç <small>128</small>	É <small>144</small>	á <small>160</small>	⋮ <small>176</small>	Ł <small>192</small>	Ǿ <small>208</small>	Ó <small>224</small>	- <small>240</small>
1	Ü <small>129</small>	æ <small>145</small>	í <small>161</small>	⋮ <small>177</small>	Ł <small>193</small>	Ɔ <small>209</small>	β <small>225</small>	± <small>241</small>
2	é <small>130</small>	Æ <small>146</small>	ó <small>162</small>	⋮ <small>178</small>	Ƨ <small>194</small>	Ê <small>210</small>	Ô <small>226</small>	= <small>242</small>
3	â <small>131</small>	ô <small>147</small>	ú <small>163</small>	<small>179</small>	Ƨ <small>195</small>	Ë <small>211</small>	Ò <small>227</small>	$\frac{3}{4}$ <small>243</small>
4	ä <small>132</small>	ö <small>148</small>	ñ <small>164</small>	† <small>180</small>	- <small>196</small>	È <small>212</small>	Õ <small>228</small>	¶ <small>244</small>
5	à <small>133</small>	ò <small>149</small>	Ñ <small>165</small>	Á <small>181</small>	† <small>197</small>	ı <small>213</small>	Õ <small>229</small>	§ <small>245</small>
6	å <small>134</small>	û <small>150</small>	ä <small>166</small>	Â <small>182</small>	ã <small>198</small>	Í <small>214</small>	μ <small>230</small>	÷ <small>246</small>
7	ç <small>135</small>	ù <small>151</small>	o <small>167</small>	À <small>183</small>	Ǻ <small>199</small>	Î <small>215</small>	þ <small>231</small>	· <small>247</small>
8	ê <small>136</small>	ÿ <small>152</small>	ç <small>168</small>	© <small>184</small>	Ł <small>200</small>	Ï <small>216</small>	þ <small>232</small>	° <small>248</small>
9	ë <small>137</small>	ö <small>153</small>	® <small>169</small>	¶ <small>185</small>	Ɔ <small>201</small>	Ɔ <small>217</small>	Ú <small>233</small>	¨ <small>249</small>
A	è <small>138</small>	Ü <small>154</small>	¬ <small>170</small>	¶ <small>186</small>	Ł <small>202</small>	Ɔ <small>218</small>	Û <small>234</small>	· <small>250</small>
B	ï <small>139</small>	ø <small>155</small>	$\frac{1}{2}$ <small>171</small>	¶ <small>187</small>	Ɔ <small>203</small>	■ <small>219</small>	Ù <small>235</small>	¹ <small>251</small>
C	î <small>140</small>	£ <small>156</small>	$\frac{1}{4}$ <small>172</small>	¶ <small>188</small>	Ɔ <small>204</small>	■ <small>220</small>	Ý <small>236</small>	³ <small>252</small>
D	ì <small>141</small>	∅ <small>157</small>	ı <small>173</small>	¢ <small>189</small>	= <small>205</small>	ı <small>221</small>	Ý <small>237</small>	² <small>253</small>
E	Ä <small>142</small>	× <small>158</small>	« <small>174</small>	¥ <small>190</small>	¶ <small>206</small>	Î <small>222</small>	— <small>238</small>	■ <small>254</small>
F	Å <small>143</small>	f <small>159</small>	» <small>175</small>	ˆ <small>191</small>	¤ <small>207</small>	■ <small>223</small>	ˆ <small>239</small>	SP <small>255</small>

Page 3 (PC860: Portuguese)

HEX	8	9	A	B	C	D	E	F
0	Ç <small>128</small>	É <small>144</small>	á <small>160</small>	⋮ <small>176</small>	Ł <small>192</small>	⋮ <small>208</small>	α <small>224</small>	≡ <small>240</small>
1	ü <small>129</small>	À <small>145</small>	í <small>161</small>	⋮ <small>177</small>	⊥ <small>193</small>	⊥ <small>209</small>	β <small>225</small>	± <small>241</small>
2	é <small>130</small>	È <small>146</small>	ó <small>162</small>	⋮ <small>178</small>	τ <small>194</small>	π <small>210</small>	Γ <small>226</small>	≥ <small>242</small>
3	â <small>131</small>	ô <small>147</small>	ú <small>163</small>	<small>179</small>	† <small>195</small>	⋮ <small>211</small>	π <small>227</small>	≤ <small>243</small>
4	ã <small>132</small>	õ <small>148</small>	ñ <small>164</small>	† <small>180</small>	- <small>196</small>	⋮ <small>212</small>	Σ <small>228</small>	ƒ <small>244</small>
5	à <small>133</small>	ò <small>149</small>	Ñ <small>165</small>	† <small>181</small>	† <small>197</small>	ƒ <small>213</small>	σ <small>229</small>	↓ <small>245</small>
6	Á <small>134</small>	Ú <small>150</small>	ä <small>166</small>	<small>182</small>	† <small>198</small>	π <small>214</small>	μ <small>230</small>	÷ <small>246</small>
7	ç <small>135</small>	ù <small>151</small>	º <small>167</small>	π <small>183</small>	<small>199</small>	<small>215</small>	τ <small>231</small>	≈ <small>247</small>
8	ê <small>136</small>	ì <small>152</small>	¿ <small>168</small>	† <small>184</small>	⋮ <small>200</small>	† <small>216</small>	φ <small>232</small>	° <small>248</small>
9	Ê <small>137</small>	õ <small>153</small>	ò <small>169</small>	<small>185</small>	ƒ <small>201</small>	↓ <small>217</small>	θ <small>233</small>	• <small>249</small>
A	è <small>138</small>	Ü <small>154</small>	¬ <small>170</small>	<small>186</small>	⋮ <small>202</small>	ƒ <small>218</small>	Ω <small>234</small>	• <small>250</small>
B	Í <small>139</small>	ϕ <small>155</small>	$\frac{1}{2}$ <small>171</small>	π <small>187</small>	⊥ <small>203</small>	■ <small>219</small>	δ <small>235</small>	√ <small>251</small>
C	Ô <small>140</small>	£ <small>156</small>	$\frac{1}{4}$ <small>172</small>	⋮ <small>188</small>	<small>204</small>	■ <small>220</small>	ω <small>236</small>	n <small>252</small>
D	ì <small>141</small>	Û <small>157</small>	ï <small>173</small>	⋮ <small>189</small>	= <small>205</small>	<small>221</small>	φ <small>237</small>	² <small>253</small>
E	Ǻ <small>142</small>	℞ <small>158</small>	« <small>174</small>	↓ <small>190</small>	<small>206</small>	<small>222</small>	ε <small>238</small>	■ <small>254</small>
F	Â <small>143</small>	Ó <small>159</small>	» <small>175</small>	† <small>191</small>	⊥ <small>207</small>	■ <small>223</small>	∩ <small>239</small>	SP <small>255</small>

HEX	8	9	A	B	C	D	E	F
0	Ç 128	É 144	Ì 160	⋮ 176	Ł 192	⋈ 208	ɑ 224	≡ 240
1	Ü 129	È 145	Í 161	⋷ 177	⊥ 193	⌣ 209	β 225	± 241
2	É 130	Ê 146	Ó 162	⋸ 178	⊢ 194	⋈ 210	Γ 226	≥ 242
3	Â 131	Ô 147	Ú 163	⋯ 179	⊣ 195	⋈ 211	Π 227	≤ 243
4	Â 132	Ë 148	Û 164	⋱ 180	– 196	⌣ 212	Σ 228	ƒ 244
5	À 133	Ï 149	Ü 165	⋴ 181	† 197	ƒ 213	σ 229	℄ 245
6	ŋ 134	Û 150	Ẓ 166	⋵ 182	‡ 198	π 214	μ 230	÷ 246
7	Ç 135	Ù 151	Ẕ 167	⋶ 183	‡ 199	⋈ 215	τ 231	≈ 247
8	Ê 136	Ẁ 152	Ï 168	⋷ 184	ℒ 200	‡ 216	φ 232	° 248
9	Ë 137	Û 153	ƒ 169	⋸ 185	ƒ 201	℄ 217	θ 233	• 249
A	È 138	Û 154	ƒ 170	⋹ 186	⋈ 202	ƒ 218	Ω 234	• 250
B	Ï 139	ϕ 155	½ 171	⋺ 187	⌣ 203	■ 219	δ 235	√ 251
C	Î 140	£ 156	¼ 172	⋻ 188	⋈ 204	■ 220	ω 236	n 252
D	= 141	Û 157	¾ 173	⋼ 189	= 205	■ 221	φ 237	² 253
E	Â 142	Û 158	« 174	⋽ 190	⋈ 206	■ 222	ε 238	■ 254
F	§ 143	f 159	» 175	⋿ 191	⋈ 207	■ 223	∩ 239	SP 255

HEX	8	9	A	B	C	D	E	F
0	Ç <small>128</small>	É <small>144</small>	á <small>160</small>	⌘ <small>176</small>	Ł <small>192</small>	⌘ <small>208</small>	ɑ <small>224</small>	≡ <small>240</small>
1	Ü <small>129</small>	æ <small>145</small>	í <small>161</small>	⌘ <small>177</small>	Ł <small>193</small>	⌘ <small>209</small>	β <small>225</small>	± <small>241</small>
2	é <small>130</small>	Æ <small>146</small>	ó <small>162</small>	⌘ <small>178</small>	Τ <small>194</small>	Π <small>210</small>	Γ <small>226</small>	≥ <small>242</small>
3	â <small>131</small>	ô <small>147</small>	ú <small>163</small>	⌘ <small>179</small>	ƒ <small>195</small>	⌘ <small>211</small>	π <small>227</small>	≤ <small>243</small>
4	ä <small>132</small>	ö <small>148</small>	ñ <small>164</small>	† <small>180</small>	- <small>196</small>	ƒ <small>212</small>	Σ <small>228</small>	ƒ <small>244</small>
5	à <small>133</small>	ò <small>149</small>	Ñ <small>165</small>	† <small>181</small>	† <small>197</small>	ƒ <small>213</small>	σ <small>229</small>	ƒ <small>245</small>
6	å <small>134</small>	û <small>150</small>	ä <small>166</small>	‡ <small>182</small>	ƒ <small>198</small>	π <small>214</small>	μ <small>230</small>	÷ <small>246</small>
7	ç <small>135</small>	ù <small>151</small>	ø <small>167</small>	π <small>183</small>	‡ <small>199</small>	‡ <small>215</small>	τ <small>231</small>	≈ <small>247</small>
8	ê <small>136</small>	ÿ <small>152</small>	ÿ <small>168</small>	ƒ <small>184</small>	⌘ <small>200</small>	† <small>216</small>	φ <small>232</small>	° <small>248</small>
9	ë <small>137</small>	ö <small>153</small>	ƒ <small>169</small>	‡ <small>185</small>	ƒ <small>201</small>	ƒ <small>217</small>	θ <small>233</small>	• <small>249</small>
A	è <small>138</small>	ü <small>154</small>	ƒ <small>170</small>	‡ <small>186</small>	⌘ <small>202</small>	ƒ <small>218</small>	Ω <small>234</small>	• <small>250</small>
B	ï <small>139</small>	ø <small>155</small>	½ <small>171</small>	π <small>187</small>	⌘ <small>203</small>	■ <small>219</small>	δ <small>235</small>	√ <small>251</small>
C	î <small>140</small>	£ <small>156</small>	¼ <small>172</small>	‡ <small>188</small>	‡ <small>204</small>	■ <small>220</small>	ω <small>236</small>	n <small>252</small>
D	ì <small>141</small>	Ø <small>157</small>	ı <small>173</small>	⌘ <small>189</small>	= <small>205</small>	■ <small>221</small>	φ <small>237</small>	² <small>253</small>
E	Ä <small>142</small>	ƒ <small>158</small>	« <small>174</small>	ƒ <small>190</small>	‡ <small>206</small>	■ <small>222</small>	ε <small>238</small>	■ <small>254</small>
F	Å <small>143</small>	f <small>159</small>	ⱥ <small>175</small>	ƒ <small>191</small>	⌘ <small>207</small>	■ <small>223</small>	∩ <small>239</small>	SP <small>255</small>

HEX	8	9	A	B	C	D	E	F
0	Ç 128	Ï 144	ï 160	⋯ 176	Ł 192	Ƨ 208	Ʒ 224	- 240
1	ü 129	SP 145	ĩ 161	⋮ 177	⊥ 193	Ƴ 209	η 225	± 241
2	é 130	ð 146	ó 162	⋱ 178	Ƨ 194	ϕ 210	θ 226	υ 242
3	â 131	ô 147	ú 163	l 179	Ƨ 195	χ 211	ł 227	φ 243
4	ä 132	ö 148	À 164	† 180	- 196	ψ 212	κ 228	χ 244
5	à 133	Ƴ 149	Β 165	Ƨ 181	† 197	Ω 213	λ 229	§ 245
6	À 134	û 150	Γ 166	Λ 182	Π 198	α 214	μ 230	ψ 246
7	ç 135	ù 151	Δ 167	Μ 183	Ρ 199	β 215	ν 231	· 247
8	ê 136	Ϻ 152	Ε 168	Ν 184	ℒ 200	γ 216	ξ 232	° 248
9	ë 137	ö 153	Ζ 169	‡ 185	Ɔ 201	ƶ 217	ο 233	¨ 249
A	è 138	Û 154	Η 170	‖ 186	℄ 202	Γ 218	π 234	ω 250
B	ï 139	á 155	½ 171	π 187	π̄ 203	■ 219	ρ 235	Û 251
C	î 140	£ 156	θ 172	ϣ 188	Ɔ̄ 204	■ 220	σ 236	Ü 252
D	Ë 141	é 157	Ι 173	≡ 189	= 205	δ 221	ς 237	ώ 253
E	Ä 142	ñ 158	« 174	Ο 190	≠ 206	ε 222	τ 238	■ 254
F	Ĥ 143	í 159	» 175	Γ 191	Σ 207	■ 223	˘ 239	SP 255

HEX	8	9	A	B	C	D	E	F
0	Ç 128	É 144	á 160	☐ 176	L 192	SP 208	Ó 224	- 240
1	ü 129	Ĉ 145	í 161	☐ 177	⊥ 193	SP 209	β 225	SP 241
2	é 130	Ċ 146	ó 162	☐ 178	⊥ 194	Ê 210	ô 226	ℓ 242
3	â 131	ô 147	ú 163	179	† 195	Ë 211	ò 227	ħ 243
4	ä 132	ö 148	ñ 164	† 180	- 196	È 212	ğ 228	˘ 244
5	à 133	ò 149	Ñ 165	Á 181	† 197	ı 213	ğ 229	§ 245
6	ĉ 134	û 150	ǧ 166	Â 182	Ŝ 198	Í 214	μ 230	÷ 246
7	ç 135	ù 151	ǧ 167	À 183	Ŝ 199	Î 215	℥ 231	˙ 247
8	ê 136	î 152	Ĥ 168	Ş 184	℔ 200	Ï 216	ħ 232	° 248
9	ë 137	ö 153	ĥ 169	185	℔ 201	Ɔ 217	ú 233	¨ 249
A	è 138	ü 154	SP 170	186	℔ 202	Ɔ 218	û 234	˙ 250
B	ï 139	ĝ 155	½ 171	187	℔ 203	■ 219	ù 235	SP 251
C	î 140	£ 156	Ĵ 172	188	℔ 204	■ 220	Û 236	³ 252
D	ì 141	Ĝ 157	Ş 173	Ž 189	= 205	SP 221	Û 237	² 253
E	Ä 142	× 158	« 174	Ž 190	℔ 206	Î 222	• 238	■ 254
F	Ĉ 143	Ĵ 159	» 175	Ɔ 191	¤ 207	■ 223	˘ 239	SP 255

HEX	8	9	A	B	C	D	E	F
0	Ç 128	É 144	á 160	☼ 176	Ł 192	o 208	Ó 224	- 240
1	ü 129	æ 145	í 161	☼ 177	ł 193	a 209	ß 225	± 241
2	é 130	Æ 146	ó 162	☼ 178	ƚ 194	Ê 210	Ô 226	SP 242
3	â 131	ô 147	ú 163	l 179	ƚ 195	Ë 211	Ò 227	¼ 243
4	ä 132	ö 148	ñ 164	l 180	- 196	È 212	Õ 228	¶ 244
5	à 133	ò 149	Ñ 165	Á 181	† 197	€ 213	Õ 229	§ 245
6	å 134	û 150	ğ 166	Â 182	ã 198	Í 214	μ 230	÷ 246
7	ç 135	ù 151	ğ 167	À 183	Ǻ 199	Î 215	SP 231	· 247
8	ê 136	î 152	ı 168	© 184	ℒ 200	İ 216	× 232	° 248
9	ë 137	ö 153	® 169	∥ 185	℞ 201	Ƶ 217	Ú 233	¨ 249
A	è 138	ü 154	¬ 170	∥ 186	≡ 202	ƶ 218	Û 234	• 250
B	ï 139	ø 155	½ 171	∥ 187	≡ 203	■ 219	Ü 235	¹ 251
C	î 140	£ 156	¼ 172	∥ 188	≡ 204	■ 220	İ 236	³ 252
D	ı 141	Ø 157	ı 173	¢ 189	= 205	ı 221	ÿ 237	² 253
E	Ä 142	Ş 158	« 174	¥ 190	≡ 206	Î 222	ˉ 238	■ 254
F	Å 143	Ş 159	» 175	ł 191	¤ 207	■ 223	˘ 239	SP 255

Page 14 (PC737: Greek)

HEX	8	9	A	B	C	D	E	F
0	Α <small>128</small>	Ρ <small>144</small>	Λ <small>160</small>	⋮ <small>176</small>	Λ <small>192</small>	⋮ <small>208</small>	ω <small>224</small>	Ω <small>240</small>
1	Β <small>129</small>	Σ <small>145</small>	Κ <small>161</small>	⋮ <small>177</small>	⊥ <small>193</small>	⊥ <small>209</small>	ά <small>225</small>	± <small>241</small>
2	Γ <small>130</small>	Τ <small>146</small>	λ <small>162</small>	⋮ <small>178</small>	Τ <small>194</small>	Π <small>210</small>	έ <small>226</small>	≥ <small>242</small>
3	Δ <small>131</small>	Υ <small>147</small>	μ <small>163</small>	<small>179</small>	† <small>195</small>	⋮ <small>211</small>	ή <small>227</small>	≤ <small>243</small>
4	Ε <small>132</small>	Φ <small>148</small>	ν <small>164</small>	† <small>180</small>	- <small>196</small>	⋮ <small>212</small>	ϊ <small>228</small>	ï <small>244</small>
5	Ζ <small>133</small>	Χ <small>149</small>	Ξ <small>165</small>	† <small>181</small>	† <small>197</small>	Ɔ <small>213</small>	ί <small>229</small>	ÿ <small>245</small>
6	Η <small>134</small>	Ψ <small>150</small>	Ο <small>166</small>	<small>182</small>	† <small>198</small>	π <small>214</small>	ό <small>230</small>	÷ <small>246</small>
7	Θ <small>135</small>	Ω <small>151</small>	π <small>167</small>	π <small>183</small>	<small>199</small>	<small>215</small>	ύ <small>231</small>	≈ <small>247</small>
8	Ι <small>136</small>	α <small>152</small>	ρ <small>168</small>	† <small>184</small>	⋮ <small>200</small>	† <small>216</small>	ü <small>232</small>	° <small>248</small>
9	Κ <small>137</small>	β <small>153</small>	σ <small>169</small>	<small>185</small>	Ɔ <small>201</small>	Ɔ <small>217</small>	ώ <small>233</small>	• <small>249</small>
A	Λ <small>138</small>	γ <small>154</small>	ς <small>170</small>	<small>186</small>	⋮ <small>202</small>	γ <small>218</small>	Ά <small>234</small>	• <small>250</small>
B	Μ <small>139</small>	δ <small>155</small>	τ <small>171</small>	π <small>187</small>	⊥ <small>203</small>	■ <small>219</small>	Έ <small>235</small>	√ <small>251</small>
C	Ν <small>140</small>	ε <small>156</small>	υ <small>172</small>	⋮ <small>188</small>	<small>204</small>	■ <small>220</small>	Ή <small>236</small>	η <small>252</small>
D	Ξ <small>141</small>	ζ <small>157</small>	φ <small>173</small>	⋮ <small>189</small>	= <small>205</small>	<small>221</small>	Ί <small>237</small>	² <small>253</small>
E	Ο <small>142</small>	η <small>158</small>	χ <small>174</small>	Ɔ <small>190</small>	<small>206</small>	<small>222</small>	Ό <small>238</small>	■ <small>254</small>
F	Π <small>143</small>	θ <small>159</small>	ψ <small>175</small>	† <small>191</small>	⊥ <small>207</small>	■ <small>223</small>	Υ <small>239</small>	SP <small>255</small>

HEX	8	9	A	B	C	D	E	F
0	SP 128	SP 144	SP 160	° 176	ÿ 192	Π 208	Û 224	π 240
1	SP 129	SP 145	‘ 161	± 177	Α 193	Ρ 209	α 225	ρ 241
2	SP 130	SP 146	’ 162	² 178	Β 194	SP 210	β 226	ς 242
3	SP 131	SP 147	£ 163	³ 179	Γ 195	Σ 211	γ 227	σ 243
4	SP 132	SP 148	€ 164	´ 180	Δ 196	Τ 212	δ 228	τ 244
5	SP 133	SP 149	Ⓟ 165	ˆ 181	Ε 197	Υ 213	ε 229	υ 245
6	SP 134	SP 150	¡ 166	À 182	Ζ 198	Φ 214	ζ 230	φ 246
7	SP 135	SP 151	§ 167	• 183	Η 199	Χ 215	η 231	χ 247
8	SP 136	SP 152	¨ 168	Έ 184	Θ 200	Ψ 216	θ 232	ψ 248
9	SP 137	SP 153	© 169	Η 185	Ι 201	Ω 217	ι 233	ω 249
A	SP 138	SP 154	• 170	Ϊ 186	Κ 202	ΐ 218	κ 234	ϊ 250
B	SP 139	SP 155	« 171	» 187	Λ 203	ÿ 219	λ 235	ÿ 251
C	SP 140	SP 156	¬ 172	Ό 188	Μ 204	ά 220	μ 236	ό 252
D	SP 141	SP 157	- 173	½ 189	Ν 205	έ 221	ν 237	ύ 253
E	SP 142	SP 158	SP 174	Υ 190	Ξ 206	ή 222	ξ 238	ώ 254
F	SP 143	SP 159	- 175	Ϟ 191	Ο 207	ί 223	ο 239	SP 255

HEX	8	9	A	B	C	D	E	F
0	€ 128	SP 144	SP 160	° 176	À 192	Ð 208	à 224	ð 240
1	SP 129	‘ 145	ì 161	± 177	Á 193	Ñ 209	á 225	ñ 241
2	, 130	’ 146	¢ 162	² 178	Â 194	Ò 210	â 226	ò 242
3	f 131	“ 147	£ 163	³ 179	Ã 195	Ó 211	ã 227	ó 243
4	” 132	” 148	¤ 164	´ 180	Ä 196	Ô 212	ä 228	ô 244
5	… 133	• 149	¥ 165	µ 181	Å 197	Õ 213	å 229	õ 245
6	† 134	- 150	ï 166	¶ 182	Æ 198	Ö 214	æ 230	ö 246
7	‡ 135	- 151	§ 167	· 183	Ç 199	× 215	ç 231	÷ 247
8	^ 136	~ 152	¨ 168	¸ 184	È 200	Ø 216	è 232	ø 248
9	‰ 137	™ 153	© 169	¹ 185	É 201	Ù 217	é 233	ù 249
A	Š 138	š 154	ª 170	º 186	Ê 202	Ú 218	ê 234	ú 250
B	< 139	> 155	« 171	» 187	Ë 203	Û 219	ë 235	û 251
C	Œ 140	œ 156	¬ 172	¼ 188	Ì 204	Ü 220	ì 236	ü 252
D	SP 141	SP 157	- 173	½ 189	Í 205	Ý 221	í 237	ý 253
E	Ž 142	ž 158	® 174	¾ 190	Î 206	Þ 222	î 238	þ 254
F	SP 143	ÿ 159	- 175	¿ 191	Ï 207	ß 223	ï 239	ÿ 255

HEX	8	9	A	B	C	D	E	F
0	А <small>128</small>	Р <small>144</small>	а <small>160</small>	⌘ <small>176</small>	Л <small>192</small>	л <small>208</small>	р <small>224</small>	ё <small>240</small>
1	Б <small>129</small>	С <small>145</small>	б <small>161</small>	⌘ <small>177</small>	л <small>193</small>	л <small>209</small>	с <small>225</small>	ё <small>241</small>
2	В <small>130</small>	Т <small>146</small>	в <small>162</small>	⌘ <small>178</small>	т <small>194</small>	п <small>210</small>	т <small>226</small>	ё <small>242</small>
3	Г <small>131</small>	У <small>147</small>	г <small>163</small>	⌘ <small>179</small>	т <small>195</small>	л <small>211</small>	у <small>227</small>	ё <small>243</small>
4	Д <small>132</small>	Ф <small>148</small>	д <small>164</small>	† <small>180</small>	— <small>196</small>	л <small>212</small>	ф <small>228</small>	ї <small>244</small>
5	Е <small>133</small>	Х <small>149</small>	е <small>165</small>	† <small>181</small>	† <small>197</small>	г <small>213</small>	х <small>229</small>	ї <small>245</small>
6	Ж <small>134</small>	Ц <small>150</small>	ж <small>166</small>	⌘ <small>182</small>	† <small>198</small>	п <small>214</small>	ц <small>230</small>	ў <small>246</small>
7	З <small>135</small>	Ч <small>151</small>	з <small>167</small>	п <small>183</small>	⌘ <small>199</small>	⌘ <small>215</small>	ч <small>231</small>	ў <small>247</small>
8	И <small>136</small>	Ш <small>152</small>	и <small>168</small>	‡ <small>184</small>	л <small>200</small>	† <small>216</small>	ш <small>232</small>	° <small>248</small>
9	Й <small>137</small>	Щ <small>153</small>	й <small>169</small>	⌘ <small>185</small>	г <small>201</small>	⌘ <small>217</small>	щ <small>233</small>	• <small>249</small>
A	К <small>138</small>	Ъ <small>154</small>	к <small>170</small>	⌘ <small>186</small>	л <small>202</small>	г <small>218</small>	ъ <small>234</small>	• <small>250</small>
B	Л <small>139</small>	Ы <small>155</small>	л <small>171</small>	⌘ <small>187</small>	л <small>203</small>	■ <small>219</small>	ы <small>235</small>	√ <small>251</small>
C	М <small>140</small>	Ь <small>156</small>	м <small>172</small>	⌘ <small>188</small>	⌘ <small>204</small>	■ <small>220</small>	ь <small>236</small>	№ <small>252</small>
D	Н <small>141</small>	Э <small>157</small>	н <small>173</small>	⌘ <small>189</small>	= <small>205</small>	⌘ <small>221</small>	э <small>237</small>	¤ <small>253</small>
E	О <small>142</small>	Ю <small>158</small>	о <small>174</small>	⌘ <small>190</small>	⌘ <small>206</small>	⌘ <small>222</small>	ю <small>238</small>	■ <small>254</small>
F	П <small>143</small>	Я <small>159</small>	п <small>175</small>	⌘ <small>191</small>	⌘ <small>207</small>	■ <small>223</small>	я <small>239</small>	SP <small>255</small>

HEX	8	9	A	B	C	D	E	F
0	Ç <small>128</small>	É <small>144</small>	á <small>160</small>	⌘ <small>176</small>	Ł <small>192</small>	đ <small>208</small>	Ó <small>224</small>	- <small>240</small>
1	ü <small>129</small>	Ĺ <small>145</small>	í <small>161</small>	⌘ <small>177</small>	Ł <small>193</small>	Đ <small>209</small>	β <small>225</small>	˘ <small>241</small>
2	é <small>130</small>	Í <small>146</small>	ó <small>162</small>	⌘ <small>178</small>	Ƨ <small>194</small>	Đ <small>210</small>	ô <small>226</small>	˙ <small>242</small>
3	â <small>131</small>	ô <small>147</small>	ú <small>163</small>	ı <small>179</small>	Ƨ <small>195</small>	Ě <small>211</small>	Ń <small>227</small>	˘ <small>243</small>
4	ä <small>132</small>	ö <small>148</small>	À <small>164</small>	ı <small>180</small>	- <small>196</small>	đ <small>212</small>	ń <small>228</small>	˘ <small>244</small>
5	û <small>133</small>	Ľ <small>149</small>	ą <small>165</small>	Á <small>181</small>	† <small>197</small>	Ň <small>213</small>	ň <small>229</small>	§ <small>245</small>
6	ć <small>134</small>	ĩ <small>150</small>	ž <small>166</small>	Â <small>182</small>	Ǻ <small>198</small>	í <small>214</small>	š <small>230</small>	÷ <small>246</small>
7	ç <small>135</small>	ś <small>151</small>	ž <small>167</small>	Ě <small>183</small>	ǻ <small>199</small>	î <small>215</small>	š <small>231</small>	˙ <small>247</small>
8	ł <small>136</small>	ś <small>152</small>	Ę <small>168</small>	Ş <small>184</small>	Ł <small>200</small>	ě <small>216</small>	Ŕ <small>232</small>	° <small>248</small>
9	ë <small>137</small>	ö <small>153</small>	ę <small>169</small>	ı <small>185</small>	Ƨ <small>201</small>	ı <small>217</small>	Ú <small>233</small>	˘ <small>249</small>
A	õ <small>138</small>	ü <small>154</small>	€ <small>170</small>	ı <small>186</small>	Ł <small>202</small>	ı <small>218</small>	ř <small>234</small>	˙ <small>250</small>
B	õ <small>139</small>	ť <small>155</small>	ž <small>171</small>	ı <small>187</small>	Ƨ <small>203</small>	■ <small>219</small>	Ů <small>235</small>	ů <small>251</small>
C	î <small>140</small>	ť <small>156</small>	č <small>172</small>	ı <small>188</small>	Ƨ <small>204</small>	■ <small>220</small>	ý <small>236</small>	ř <small>252</small>
D	ž <small>141</small>	ł <small>157</small>	š <small>173</small>	ž <small>189</small>	= <small>205</small>	ı <small>221</small>	ý <small>237</small>	ř <small>253</small>
E	Ǻ <small>142</small>	× <small>158</small>	« <small>174</small>	ž <small>190</small>	Ƨ <small>206</small>	Ů <small>222</small>	ť <small>238</small>	■ <small>254</small>
F	ć <small>143</small>	č <small>159</small>	» <small>175</small>	ı <small>191</small>	Ǻ <small>207</small>	■ <small>223</small>	˘ <small>239</small>	SP <small>255</small>

HEX	8	9	A	B	C	D	E	F
0	Ç 128	É 144	á 160	⌘ 176	Ł 192	Š 208	Ó 224	- 240
1	Ü 129	æ 145	í 161	⌘ 177	Ł 193	Đ 209	β 225	± 241
2	é 130	Æ 146	ó 162	⌘ 178	Ƨ 194	Ê 210	Ô 226	= 242
3	â 131	ô 147	ú 163	⌘ 179	Ƨ 195	Ë 211	Ò 227	$\frac{3}{4}$ 243
4	ä 132	ö 148	ñ 164	⌘ 180	- 196	È 212	Õ 228	¶ 244
5	à 133	ò 149	Ñ 165	Á 181	† 197	€ 213	Õ 229	§ 245
6	å 134	û 150	ä 166	Â 182	ã 198	Í 214	μ 230	÷ 246
7	ç 135	ù 151	ó 167	À 183	Ä 199	Î 215	þ 231	· 247
8	ê 136	ÿ 152	¿ 168	© 184	Ł 200	Ï 216	þ 232	° 248
9	ë 137	ö 153	® 169	⌘ 185	Ƨ 201	Ɔ 217	Ú 233	¨ 249
A	è 138	Ü 154	¬ 170	⌘ 186	Ł 202	Ɔ 218	Û 234	· 250
B	ï 139	ø 155	$\frac{1}{2}$ 171	⌘ 187	Ƨ 203	■ 219	Ù 235	¹ 251
C	î 140	£ 156	$\frac{1}{4}$ 172	⌘ 188	Ƨ 204	■ 220	Ý 236	³ 252
D	ì 141	Ø 157	ì 173	¢ 189	= 205	¡ 221	Ý 237	² 253
E	Ä 142	× 158	« 174	¥ 190	≠ 206	Ï 222	— 238	■ 254
F	Å 143	f 159	» 175	Ƨ 191	¤ 207	■ 223	˘ 239	SP 255

HEX	8	9	A	B	C	D	E	F
0	ร 128	อ 144	SP 160	ฌ 176	ย 192	เ 208	· 224	๒๓ 240
1	๓ 129	๑ 145	ก 161	ฌ 177	ร 193	แ 209	๒ 225	๒๔ 241
2	ล 130	๒ 146	ป 162	ด 178	ถ 194	โ 210	๓ 226	๒๕ 242
3	จ 131	๓ 147	ค 163	ต 179	ฉ 195	ใ 211	+ 227	๒๖ 243
4	ี 132	๔ 148	ฆ 164	ถ 180	ว 196	ไ 212	๔ 228	๒๗ 244
5	เ 133	๕ 149	ง 165	ท 181	ศ 197	ำ 213	· 229	๒๘ 245
6	๓ 134	๖ 150	จ 166	ธ 182	ษ 198	ำ 214	๐ 230	๒๙ 246
7	๓ 135	๗ 151	ฉ 167	น 183	ส 199	๑ 215	๑๒ 231	๓๐ 247
8	๓ 136	๘ 152	ช 168	บ 184	ห 200	๒ 216	๑๓ 232	๓๑ 248
9	๓ 137	๙ 153	ซ 169	ป 185	ฬ 201	๓ 217	๑๔ 233	๓๒ 249
A	๓ 138	๐ 154	ฌ 170	ผ 186	อ 202	๔ 218	๑๕ 234	๓๓ 250
B	๓ 139	๑ 155	ฌ 171	ผ 187	ฮ 203	๕ 219	๑๖ 235	๓๔ 251
C	← 140	๑ 156	ฌ 172	ผ 188	๕ 204	๖ 220	๑๗ 236	๓๕ 252
D	↑ 141	๑ 157	ฌ 173	ผ 189	ภ 205	๗ 221	๑๘ 237	๓๖ 253
E	→ 142	๑ 158	ฌ 174	ภ 190	ำ 206	๐ 222	๑๙ 238	๓๗ 254
F	↓ 143	๑ 159	ฑ 175	ม 191	ำ 207	๑ 223	๒๐ 239	SP 255

HEX	8	9	A	B	C	D	E	F
0	e- 128	h+ 144	เ 160	๕๓ 176	ภ 192	๕๕ 208	เ 224	๐ 240
1	ee 129	h- 145	ก 161	ท 177	ม 193	๕ 209	แ 225	๑ 241
2	e3 130	๕๕ 146	ป 162	ฝ 178	ย 194	า 210	โ 226	๒ 242
3	e+ 131	๕๖ 147	ข 163	ผ 179	ร 195	ำ 211	ใ 227	๓ 243
4	d- 132	๕+ 148	ค 164	ด 180	ถ 196	๗ 212	ไ 228	๔ 244
5	de 133	๐- 149	ค 165	ด 181	ฉ 197	๘ 213	า 229	๕ 245
6	d3 134	๐๕ 150	ฆ 166	ถ 182	ภ 198	๙ 214	ำ 230	๖ 246
7	d+ 135	๐๖ 151	ง 167	ท 183	ว 199	๘ 215	๙ 231	๗ 247
8	da 136	๐+ 152	จ 168	ช 184	ศ 200	๐ 216	๐ 232	๘ 248
9	d- 137	๐ 153	ฉ 169	น 185	ช 201	๑ 217	๑ 233	๙ 249
A	๕๕ 138	๐ 154	ช 170	บ 186	ส 202	๑ 218	๑ 234	๐ 250
B	๕๖ 139	๐ 155	ซ 171	ป 187	ห 203	๑ 219	๑ 235	๑ 251
C	๕+ 140	๐ 156	ฌ 172	ผ 188	ฬ 204	๑ 220	๑ 236	๑ 252
D	๕- 141	๐ 157	ญ 173	ผ 189	อ 205	๑ 221	๑ 237	๑ 253
E	๕๕ 142	๐ 158	ฎ 174	ฬ 190	ฮ 206	๑ 222	๑ 238	๑ 254
F	๕๖ 143	๐ 159	ฏ 175	ฬ 191	า 207	๑ 223	๑ 239	SP 255

Page 26 (TIS18: Thai)

HEX	8	9	A	B	C	D	E	F
0	┌ 128	๙ 144	SP 160	๙๙ 176	ภ 192	๕๕ 208	ไ 224	๐ 240
1	┐ 129	๑ 145	ก 161	ท 177	ม 193	๕ 209	แ 225	๑ 241
2	└ 130	๕- 146	ป 162	ฌ 178	ย 194	า 210	โ 226	๒ 242
3	┘ 131	๕๕ 147	บ 163	ฌ 179	ร 195	ำ 211	ใ 227	๓ 243
4	┌ 132	๕๕ 148	ค 164	ด 180	ถ 196	๗ 212	ใ 228	๔ 244
5	└ 133	๕+ 149	ค 165	ด 181	ฉ 197	๗ 213	า 229	๕ 245
6	┐ 134	๗- 150	ฆ 166	ถ 182	ภ 198	๗ 214	ำ 230	๖ 246
7	┘ 135	๗๕ 151	ง 167	ท 183	ว 199	๗ 215	๘ 231	๗ 247
8	┌ 136	๗๕ 152	จ 168	ธ 184	ศ 200	๘ 216	๘ 232	๘ 248
9	└ 137	๗+ 153	ฉ 169	น 185	ช 201	๘ 217	๘ 233	๙ 249
A	┐ 138	๗๗ 154	ช 170	บ 186	ส 202	๘ 218	๘ 234	๙ 250
B	■ 139	๗- 155	ช 171	ป 187	ห 203	๗- 219	+ 235	๗- 251
C	← 140	๗๕ 156	ฌ 172	ฝ 188	ฬ 204	๗๕ 220	๘ 236	๗๕ 252
D	↑ 141	๗๕ 157	ฌ 173	ฝ 189	อ 205	๗๕ 221	๘ 237	๗๕ 253
E	→ 142	๗+ 158	ฉ 174	ฝ 190	ฮ 206	๗+ 222	๘ 238	๗+ 254
F	↓ 143	๗ 159	ฉ 175	ฝ 191	า 207	๗ 223	๗ 239	SP 255

HEX	8	9	A	B	C	D	E	F
0	SP 128	SP 144	SP 160	SP 176	SP 192	é 208	SP 224	SP 240
1	SP 129	SP 145	SP 161	SP 177	SP 193	ẹ 209	ỏ 225	ủ 241
2	SP 130	SP 146	SP 162	SP 178	SP 194	ề 210	õ 226	ữ 242
3	SP 131	SP 147	SP 163	SP 179	SP 195	ễ 211	ó 227	ú 243
4	SP 132	SP 148	SP 164	SP 180	SP 196	ễ 212	ọ 228	ụ 244
5	SP 133	SP 149	SP 165	à 181	SP 197	ế 213	ồ 229	ử 245
6	SP 134	SP 150	SP 166	ả 182	ặ 198	ệ 214	ỗ 230	ữ 246
7	SP 135	SP 151	SP 167	ã 183	ầ 199	ì 215	ỗ 231	ữ 247
8	SP 136	SP 152	ă 168	á 184	ã 200	ỉ 216	ố 232	ứ 248
9	SP 137	SP 153	â 169	ạ 185	ã 201	SP 217	ộ 233	ự 249
A	SP 138	SP 154	ê 170	SP 186	ấ 202	SP 218	ờ 234	ỳ 250
B	SP 139	SP 155	ô 171	ã 187	ậ 203	SP 219	ở 235	ỷ 251
C	SP 140	SP 156	ơ 172	ã 188	è 204	ĩ 220	ỡ 236	ỹ 252
D	SP 141	SP 157	ư 173	ã 189	SP 205	í 221	ớ 237	ý 253
E	SP 142	SP 158	đ 174	ã 190	ẻ 206	ị 222	ợ 238	ỵ 254
F	SP 143	SP 159	SP 175	SP 191	ễ 207	ò 223	ù 239	SP 255

Page 31 (TCVN-3: Vietnamese)

HEX	8	9	A	B	C	D	E	F
0	SP 128	SP 144	SP 160	SP 176	SP 192	É 208	SP 224	SP 240
1	SP 129	SP 145	Ă 161	SP 177	SP 193	Ệ 209	Ỏ 225	Ủ 241
2	SP 130	SP 146	Â 162	SP 178	SP 194	Ề 210	Ỗ 226	Ữ 242
3	SP 131	SP 147	SP 163	SP 179	SP 195	Ễ 211	Ó 227	Ú 243
4	SP 132	SP 148	SP 164	SP 180	SP 196	Ễ 212	Ọ 228	Ụ 244
5	SP 133	SP 149	SP 165	À 181	SP 197	Ễ 213	Ồ 229	Ữ 245
6	SP 134	SP 150	SP 166	Ả 182	Ặ 198	Ệ 214	Ỗ 230	Ữ 246
7	SP 135	SP 151	Đ 167	Ã 183	Â 199	Ì 215	Ỗ 231	Ữ 247
8	SP 136	SP 152	SP 168	Á 184	Ã 200	Ỉ 216	Ố 232	Ứ 248
9	SP 137	SP 153	SP 169	Ạ 185	Ã 201	SP 217	Ộ 233	Ứ 249
A	SP 138	SP 154	Ê 170	SP 186	Ã 202	SP 218	Ờ 234	Ỡ 250
B	SP 139	SP 155	Ô 171	Ã 187	Ặ 203	SP 219	Ờ 235	Ỡ 251
C	SP 140	SP 156	Ớ 172	Ã 188	È 204	Ỉ 220	Ỗ 236	Ỡ 252
D	SP 141	SP 157	Ứ 173	Ã 189	SP 205	Ỉ 221	Ớ 237	Ỡ 253
E	SP 142	SP 158	SP 174	Ã 190	Ề 206	Ỉ 222	Ớ 238	Ỡ 254
F	SP 143	SP 159	SP 175	SP 191	Ễ 207	Ồ 223	Ừ 239	SP 255

HEX	8	9	A	B	C	D	E	F
0	SP 128	SP 144	ب 160	◌◌◌◌ 176	L 192	ل 208	ض 224	≡ 240
1	SP 129	◌◌◌◌ 145	ة 161	◌◌◌◌◌◌ 177	ل 193	ل 209	ط 225	◌◌◌◌ 241
2	é 130	◌◌◌◌ 146	ت 162	◌◌◌◌◌◌ 178	ل 194	ل 210	ظ 226	◌◌◌◌ 242
3	â 131	ô 147	ث 163	 179	ل 195	ل 211	ع 227	◌◌◌◌ 243
4	SP 132	◌◌◌◌ 148	ج 164	ل 180	- 196	ل 212	غ 228	◌◌◌◌ 244
5	à 133	- 149	ح 165	ل 181	ل 197	ل 213	ف 229	◌◌◌◌ 245
6	SP 134	û 150	خ 166	ل 182	ل 198	ل 214	ل 230	◌◌◌◌ 246
7	ç 135	ù 151	د 167	ل 183	ل 199	ل 215	ق 231	≈ 247
8	ê 136	ء 152	ذ 168	ل 184	ل 200	ل 216	ك 232	◌◌◌◌ 248
9	ë 137	آ 153	ر 169	ل 185	ل 201	ل 217	ل 233	◌◌◌◌ 249
A	è 138	أ 154	ز 170	ل 186	ل 202	ل 218	م 234	◌◌◌◌ 250
B	ï 139	ؤ 155	س 171	ل 187	ل 203	◌◌◌◌ 219	ن 235	√ 251
C	î 140	ع 156	ش 172	ل 188	ل 204	◌◌◌◌ 220	ه 236	n 252
D	SP 141	ل 157	ص 173	ل 189	= 205	ل 221	و 237	2 253
E	SP 142	ع 158	« 174	ل 190	ل 206	ل 222	ى 238	◌◌◌◌ 254
F	SP 143	ا 159	» 175	ل 191	ل 207	◌◌◌◌ 223	ي 239	SP 255

Page 33 (WPC775: Baltic Rim)

HEX	8	9	A	B	C	D	E	F
0	Ć <small>128</small>	É <small>144</small>	Ā <small>160</small>	⋯ <small>176</small>	Ł <small>192</small>	ą <small>208</small>	Ó <small>224</small>	- <small>240</small>
1	Ü <small>129</small>	æ <small>145</small>	Ī <small>161</small>	⋯ <small>177</small>	ł <small>193</small>	č <small>209</small>	β <small>225</small>	± <small>241</small>
2	é <small>130</small>	Æ <small>146</small>	Ó <small>162</small>	⋯ <small>178</small>	ṽ <small>194</small>	ę <small>210</small>	ō <small>226</small>	“ <small>242</small>
3	ā <small>131</small>	ō <small>147</small>	ž <small>163</small>	l <small>179</small>	ł <small>195</small>	è <small>211</small>	Ń <small>227</small>	¾ <small>243</small>
4	ä <small>132</small>	ö <small>148</small>	ž <small>164</small>	ł <small>180</small>	- <small>196</small>	i <small>212</small>	õ <small>228</small>	¶ <small>244</small>
5	ǫ <small>133</small>	Ǫ <small>149</small>	ž <small>165</small>	Ą <small>181</small>	ł <small>197</small>	š <small>213</small>	õ <small>229</small>	§ <small>245</small>
6	ǻ <small>134</small>	ϕ <small>150</small>	” <small>166</small>	Č <small>182</small>	Ų <small>198</small>	ų <small>214</small>	μ <small>230</small>	÷ <small>246</small>
7	Ć <small>135</small>	Ś <small>151</small>	ı <small>167</small>	Ę <small>183</small>	Ū <small>199</small>	ū <small>215</small>	ń <small>231</small>	” <small>247</small>
8	ł <small>136</small>	ś <small>152</small>	© <small>168</small>	É <small>184</small>	Ł <small>200</small>	ž <small>216</small>	ķ <small>232</small>	° <small>248</small>
9	ē <small>137</small>	ö <small>153</small>	® <small>169</small>	ł <small>185</small>	Ŗ <small>201</small>	ĵ <small>217</small>	ķ <small>233</small>	• <small>249</small>
A	Ŕ <small>138</small>	Ü <small>154</small>	¬ <small>170</small>	ll <small>186</small>	ll <small>202</small>	ŕ <small>218</small>	ł <small>234</small>	• <small>250</small>
B	ŕ <small>139</small>	ø <small>155</small>	½ <small>171</small>	ll <small>187</small>	ll <small>203</small>	■ <small>219</small>	ł <small>235</small>	¹ <small>251</small>
C	ī <small>140</small>	£ <small>156</small>	¼ <small>172</small>	ll <small>188</small>	ll <small>204</small>	■ <small>220</small>	ŋ <small>236</small>	³ <small>252</small>
D	ž <small>141</small>	Ø <small>157</small>	ł <small>173</small>	ł <small>189</small>	= <small>205</small>	l <small>221</small>	Ē <small>237</small>	² <small>253</small>
E	Ä <small>142</small>	× <small>158</small>	« <small>174</small>	Š <small>190</small>	ł <small>206</small>	l <small>222</small>	Ń <small>238</small>	■ <small>254</small>
F	Å <small>143</small>	¤ <small>159</small>	» <small>175</small>	ł <small>191</small>	ž <small>207</small>	■ <small>223</small>	' <small>239</small>	SP <small>255</small>

HEX	8	9	A	B	C	D	E	F
0	ђ <small>128</small>	љ <small>144</small>	а <small>160</small>	џ <small>176</small>	Љ <small>192</small>	л <small>208</small>	я <small>224</small>	- <small>240</small>
1	ћ <small>129</small>	љ <small>145</small>	А <small>161</small>	џ <small>177</small>	Љ <small>193</small>	Л <small>209</small>	р <small>225</small>	Ы <small>241</small>
2	ѓ <small>130</small>	њ <small>146</small>	б <small>162</small>	џ <small>178</small>	т <small>194</small>	м <small>210</small>	Р <small>226</small>	Ы <small>242</small>
3	ѓ <small>131</small>	њ <small>147</small>	Б <small>163</small>	Љ <small>179</small>	Т <small>195</small>	М <small>211</small>	С <small>227</small>	З <small>243</small>
4	ё <small>132</small>	ћ <small>148</small>	ц <small>164</small>	џ <small>180</small>	- <small>196</small>	н <small>212</small>	С <small>228</small>	З <small>244</small>
5	Ё <small>133</small>	ћ <small>149</small>	Ц <small>165</small>	Х <small>181</small>	† <small>197</small>	Н <small>213</small>	Т <small>229</small>	Ш <small>245</small>
6	е <small>134</small>	ќ <small>150</small>	д <small>166</small>	Х <small>182</small>	К <small>198</small>	о <small>214</small>	Т <small>230</small>	Ш <small>246</small>
7	Е <small>135</small>	ќ <small>151</small>	Д <small>167</small>	И <small>183</small>	К <small>199</small>	О <small>215</small>	У <small>231</small>	Э <small>247</small>
8	ѕ <small>136</small>	ђ <small>152</small>	е <small>168</small>	И <small>184</small>	Љ <small>200</small>	п <small>216</small>	У <small>232</small>	Э <small>248</small>
9	Ѕ <small>137</small>	ђ <small>153</small>	Е <small>169</small>	И <small>185</small>	Љ <small>201</small>	Ј <small>217</small>	Ж <small>233</small>	Щ <small>249</small>
A	і <small>138</small>	џ <small>154</small>	ф <small>170</small>	И <small>186</small>	Љ <small>202</small>	Г <small>218</small>	Ж <small>234</small>	Щ <small>250</small>
B	І <small>139</small>	џ <small>155</small>	Ф <small>171</small>	И <small>187</small>	Љ <small>203</small>	■ <small>219</small>	В <small>235</small>	Ч <small>251</small>
C	ї <small>140</small>	ю <small>156</small>	Г <small>172</small>	Ј <small>188</small>	Љ <small>204</small>	■ <small>220</small>	В <small>236</small>	Ч <small>252</small>
D	İ <small>141</small>	Ю <small>157</small>	Г <small>173</small>	Й <small>189</small>	= <small>205</small>	П <small>221</small>	Ь <small>237</small>	§ <small>253</small>
E	ј <small>142</small>	ь <small>158</small>	« <small>174</small>	Й <small>190</small>	≠ <small>206</small>	Я <small>222</small>	Ь <small>238</small>	■ <small>254</small>
F	Ј <small>143</small>	Ь <small>159</small>	» <small>175</small>	Г <small>191</small>	џ <small>207</small>	■ <small>223</small>	№ <small>239</small>	SP <small>255</small>

Page 35 (PC861: Icelandic)

HEX	8	9	A	B	C	D	E	F
0	Ç <small>128</small>	É <small>144</small>	á <small>160</small>	⌘ <small>176</small>	Ł <small>192</small>	⌘ <small>208</small>	α <small>224</small>	≡ <small>240</small>
1	Ü <small>129</small>	æ <small>145</small>	í <small>161</small>	⌘ <small>177</small>	⊥ <small>193</small>	⌘ <small>209</small>	β <small>225</small>	± <small>241</small>
2	é <small>130</small>	Æ <small>146</small>	ó <small>162</small>	⌘ <small>178</small>	τ <small>194</small>	π <small>210</small>	Γ <small>226</small>	≥ <small>242</small>
3	â <small>131</small>	ô <small>147</small>	ú <small>163</small>	<small>179</small>	† <small>195</small>	⌘ <small>211</small>	π <small>227</small>	≤ <small>243</small>
4	ä <small>132</small>	ö <small>148</small>	Á <small>164</small>	† <small>180</small>	- <small>196</small>	Ł <small>212</small>	Σ <small>228</small>	ƒ <small>244</small>
5	à <small>133</small>	þ <small>149</small>	Í <small>165</small>	† <small>181</small>	† <small>197</small>	ƒ <small>213</small>	σ <small>229</small>	↓ <small>245</small>
6	å <small>134</small>	û <small>150</small>	Ó <small>166</small>	<small>182</small>	† <small>198</small>	π <small>214</small>	μ <small>230</small>	÷ <small>246</small>
7	ç <small>135</small>	Ý <small>151</small>	Ú <small>167</small>	π <small>183</small>	<small>199</small>	<small>215</small>	τ <small>231</small>	≈ <small>247</small>
8	ê <small>136</small>	ý <small>152</small>	ÿ <small>168</small>	ƒ <small>184</small>	⌘ <small>200</small>	† <small>216</small>	φ <small>232</small>	° <small>248</small>
9	ë <small>137</small>	ö <small>153</small>	ƒ <small>169</small>	<small>185</small>	ƒ <small>201</small>	↓ <small>217</small>	θ <small>233</small>	• <small>249</small>
A	è <small>138</small>	Ü <small>154</small>	ƒ <small>170</small>	<small>186</small>	⌘ <small>202</small>	ƒ <small>218</small>	Ω <small>234</small>	• <small>250</small>
B	Ð <small>139</small>	ø <small>155</small>	½ <small>171</small>	π <small>187</small>	⌘ <small>203</small>	■ <small>219</small>	δ <small>235</small>	√ <small>251</small>
C	ð <small>140</small>	£ <small>156</small>	¼ <small>172</small>	⌘ <small>188</small>	<small>204</small>	■ <small>220</small>	ω <small>236</small>	n <small>252</small>
D	þ <small>141</small>	Ø <small>157</small>	i <small>173</small>	⌘ <small>189</small>	= <small>205</small>	<small>221</small>	φ <small>237</small>	² <small>253</small>
E	Ä <small>142</small>	⌘ <small>158</small>	« <small>174</small>	↓ <small>190</small>	<small>206</small>	<small>222</small>	ε <small>238</small>	■ <small>254</small>
F	Å <small>143</small>	f <small>159</small>	» <small>175</small>	ƒ <small>191</small>	⌘ <small>207</small>	■ <small>223</small>	∩ <small>239</small>	SP <small>255</small>

HEX	8	9	A	B	C	D	E	F
0	𐤀 128	𐤁 144	á 160	𐤃 176	𐤄 192	𐤅 208	א 224	≡ 240
1	𐤂 129	𐤃 145	í 161	𐤄 177	𐤅 193	𐤆 209	ב 225	± 241
2	𐤃 130	𐤄 146	ó 162	𐤅 178	𐤆 194	𐤇 210	ג 226	≥ 242
3	𐤄 131	𐤅 147	ú 163	𐤆 179	𐤇 195	𐤈 211	ד 227	≤ 243
4	𐤅 132	𐤆 148	ñ 164	𐤇 180	– 196	𐤉 212	ה 228	ר 244
5	𐤆 133	𐤇 149	Ñ 165	𐤈 181	† 197	𐤊 213	ו 229	י 245
6	𐤇 134	𐤈 150	ä 166	𐤉 182	𐤋 198	𐤌 214	ז 230	÷ 246
7	𐤈 135	𐤉 151	o 167	𐤊 183	𐤍 199	𐤎 215	ח 231	≈ 247
8	𐤉 136	𐤊 152	č 168	𐤋 184	𐤏 200	𐤐 216	ט 232	° 248
9	𐤊 137	𐤋 153	ƒ 169	𐤌 185	𐤑 201	𐤒 217	י 233	• 249
A	𐤋 138	𐤌 154	ƒ 170	𐤍 186	𐤓 202	𐤔 218	כ 234	• 250
B	𐤌 139	𐤍 155	½ 171	𐤎 187	𐤕 203	■ 219	ל 235	√ 251
C	𐤍 140	𐤎 156	¼ 172	𐤏 188	𐤖 204	■ 220	מ 236	n 252
D	𐤎 141	𐤏 157	i 173	𐤐 189	= 205	■ 221	נ 237	² 253
E	𐤏 142	𐤐 158	« 174	𐤑 190	𐤗 206	■ 222	ס 238	■ 254
F	𐤐 143	𐤑 159	» 175	𐤒 191	𐤘 207	■ 223	ע 239	SP 255

Page 37 (PC864: Arabic)

HEX	8	9	A	B	C	D	E	F
0	° 128	β 144	SP 160	• 176	¢ 192	ذ 208	- 224	ا 240
1	• 129	∞ 145	- 161	ا 177	ء 193	ر 209	ف 225	ا 241
2	• 130	φ 146	ل 162	٢ 178	آ 194	ز 210	ف 226	ن 242
3	√ 131	± 147	£ 163	٣ 179	أ 195	ع 211	ك 227	ه 243
4	☼ 132	½ 148	¤ 164	٤ 180	ؤ 196	ث 212	ل 228	ه 244
5	- 133	¼ 149	ل 165	ه 181	ع 197	ط 213	م 229	ي 245
6	134	≈ 150	SP 166	٦ 182	ئ 198	ظ 214	ن 230	ي 246
7	† 135	« 151	€ 167	٧ 183	ا 199	ط 215	ه 231	غ 247
8	† 136	» 152	ل 168	٨ 184	ب 200	ظ 216	و 232	ق 248
9	‡ 137	لا 153	ب 169	٩ 185	ة 201	ء 217	ي 233	لا 249
A	‡ 138	لا 154	ن 170	ف 186	ت 202	غ 218	ب 234	لا 250
B	⊥ 139	SP 155	ث 171	؛ 187	ث 203	ا 219	ض 235	ل 251
C	٦ 140	SP 156	، 172	ع 188	ج 204	ر 220	ع 236	ك 252
D	٢ 141	لا 157	ج 173	ش 189	ح 205	÷ 221	غ 237	ي 253
E	ل 142	لا 158	ح 174	ص 190	خ 206	× 222	غ 238	■ 254
F	ل 143	، 159	خ 175	؟ 191	د 207	ع 223	م 239	SP 255

HEX	8	9	A	B	C	D	E	F
0	SP 128	Ι 144	ϊ 160	⋯ 176	Λ 192	Τ 208	Ζ 224	- 240
1	SP 129	Ϊ 145	Ͽ 161	⋮ 177	⊥ 193	Υ 209	η 225	± 241
2	SP 130	ϐ 146	Ό 162	⋯ 178	Τ 194	Φ 210	θ 226	υ 242
3	SP 131	SP 147	Ό 163	Ι 179	† 195	Χ 211	Λ 227	φ 243
4	SP 132	SP 148	Α 164	† 180	- 196	Ψ 212	Κ 228	χ 244
5	SP 133	Υ 149	Β 165	Κ 181	† 197	Ω 213	λ 229	ς 245
6	Α 134	Ϊ 150	Γ 166	Λ 182	Π 198	α 214	μ 230	ψ 246
7	€ 135	© 151	Δ 167	Μ 183	Ρ 199	β 215	ν 231	™ 247
8	• 136	ϐ 152	Ε 168	Ν 184	ℒ 200	γ 216	ξ 232	° 248
9	¬ 137	² 153	Ζ 169	Η 185	Ϛ 201	ι 217	ο 233	¨ 249
A	ι 138	³ 154	Η 170	Θ 186	≡ 202	Γ 218	π 234	ω 250
B	‘ 139	ά 155	½ 171	η 187	π 203	■ 219	ρ 235	ü 251
C	’ 140	£ 156	θ 172	ϐ 188	≡ 204	■ 220	σ 236	ÿ 252
D	Έ 141	έ 157	Ι 173	≡ 189	= 205	δ 221	ς 237	ώ 253
E	- 142	ή 158	« 174	Ο 190	≡ 206	ε 222	τ 238	■ 254
F	Η 143	ί 159	» 175	Γ 191	Σ 207	■ 223	˘ 239	SP 255

Page 39 (ISO8859-2: Latin2)

HEX	8	9	A	B	C	D	E	F
0	☐ 128	L 144	SP 160	° 176	Ŕ 192	Ɔ 208	ř 224	ď 240
1	☐ 129	ł 145	Ą 161	ą 177	Á 193	Ň 209	á 225	ň 241
2	☐ 130	T 146	˘ 162	˙ 178	Â 194	Ń 210	â 226	ń 242
3	 131	ł 147	Ł 163	ł 179	Ǻ 195	Ó 211	ǻ 227	ó 243
4	ł 132	- 148	ą 164	˘ 180	Ǻ 196	Ô 212	ǻ 228	ô 244
5	J 133	ł 149	Ĺ 165	ĺ 181	Ĺ 197	Õ 213	í 229	õ 245
6	ŕ 134	■ 150	Ś 166	ś 182	Ć 198	Ö 214	ć 230	ö 246
7	■ 135	■ 151	§ 167	˘ 183	Ç 199	× 215	ç 231	÷ 247
8	© 136	Ł 152	˘ 168	˙ 184	Č 200	Ř 216	č 232	ř 248
9	ł 137	ŕ 153	Š 169	š 185	É 201	Û 217	é 233	û 249
A	ł 138	ł 154	Ş 170	ş 186	Ę 202	Ú 218	ę 234	ú 250
B	ł 139	ł 155	Ÿ 171	ÿ 187	Ě 203	Ů 219	ě 235	ů 251
C	ł 140	ł 156	Ž 172	ž 188	Ě 204	Ü 220	ě 236	ü 252
D	¢ 141	= 157	- 173	˘ 189	Í 205	Ý 221	í 237	ý 253
E	¥ 142	ł 158	Ž 174	ž 190	Î 206	Ĳ 222	î 238	Ĳ 254
F	ł 143	® 159	Ž 175	ž 191	Ď 207	ß 223	ď 239	· 255

HEX	8	9	A	B	C	D	E	F
0	SP 128	SP 144	SP 160	° 176	À 192	Ð 208	à 224	ð 240
1	SP 129	SP 145	í 161	± 177	Á 193	Ñ 209	á 225	ñ 241
2	SP 130	SP 146	¢ 162	² 178	Â 194	Ò 210	â 226	ò 242
3	SP 131	SP 147	£ 163	³ 179	Ã 195	Ó 211	ã 227	ó 243
4	SP 132	SP 148	€ 164	ž 180	Ä 196	Ô 212	ä 228	ô 244
5	SP 133	SP 149	¥ 165	μ 181	Å 197	Õ 213	å 229	õ 245
6	SP 134	SP 150	Š 166	¶ 182	Æ 198	Ö 214	æ 230	ö 246
7	SP 135	SP 151	§ 167	· 183	Ç 199	× 215	ç 231	÷ 247
8	SP 136	SP 152	š 168	ž 184	È 200	Ø 216	è 232	ø 248
9	SP 137	SP 153	@ 169	¹ 185	É 201	Ù 217	é 233	ù 249
A	SP 138	SP 154	ª 170	º 186	Ê 202	Ú 218	ê 234	ú 250
B	SP 139	SP 155	« 171	» 187	Ë 203	Û 219	ë 235	û 251
C	SP 140	SP 156	¬ 172	ƒ 188	Ì 204	Ü 220	ì 236	ü 252
D	SP 141	SP 157	- 173	œ 189	Í 205	Ý 221	í 237	ý 253
E	SP 142	SP 158	® 174	ÿ 190	Î 206	Þ 222	î 238	þ 254
F	SP 143	SP 159	- 175	ı 191	Ï 207	ß 223	ï 239	ÿ 255

HEX	8	9	A	B	C	D	E	F
0	SP 128	۴ 144	ح 160	۰ 176	L 192	ع 208	ک 224	- 240
1	SP 129	۵ 145	خ 161	۱ 177	ل 193	ع 209	ک 225	۵ 241
2	، 130	ب 146	د 162	۲ 178	T 194	ع 210	ک 226	ب 242
3	؛ 131	پ 147	ر 163	۳ 179	ل 195	غ 211	ک 227	- 243
4	؟ 132	پ 148	ز 164	۴ 180	- 196	غ 212	ل 228	۰ 244
5	” 133	پ 149	ر 165	ض 181	ل 197	غ 213	ل 229	۱ 245
6	آ 134	ت 150	ز 166	ض 182	ظ 198	غ 214	م 230	۲ 246
7	آ 135	ت 151	ث 167	ط 183	ع 199	ف 215	م 231	۳ 247
8	آ 136	ث 152	س 168	ط 184	ل 200	ف 216	ن 232	۴ 248
9	ا 137	ث 153	ع 169	ا 185	ل 201	ل 217	ن 233	۵ 249
A	ا 138	ج 154	ش 170	ا 186	ل 202	ر 218	و 234	۶ 250
B	د 139	د 155	ش 171	ا 187	ل 203	■ 219	ه 235	۷ 251
C	ء 140	ج 156	ص 172	ک 188	ل 204	■ 220	ه 236	۸ 252
D	أ 141	چ 157	ط 173	و 189	= 205	ق 221	ه 237	۹ 253
E	أ 142	خ 158	« 174	ظ 190	ل 206	ق 222	ه 238	■ 254
F	ؤ 143	ح 159	» 175	گ 191	SP 207	■ 223	ی 239	SP 255

HEX	8	9	A	B	C	D	E	F
0	Ç <small>128</small>	É <small>144</small>	á <small>160</small>	⋯ <small>176</small>	Ł <small>192</small>	ą <small>208</small>	ɑ <small>224</small>	≡ <small>240</small>
1	ü <small>129</small>	æ <small>145</small>	í <small>161</small>	⋯ <small>177</small>	Ł̇ <small>193</small>	č <small>209</small>	β <small>225</small>	± <small>241</small>
2	é <small>130</small>	Æ <small>146</small>	ó <small>162</small>	⋯ <small>178</small>	Τ <small>194</small>	ę <small>210</small>	Γ <small>226</small>	≥ <small>242</small>
3	â <small>131</small>	ô <small>147</small>	ú <small>163</small>	l̇ <small>179</small>	ƒ <small>195</small>	è <small>211</small>	Π <small>227</small>	≤ <small>243</small>
4	ä <small>132</small>	ö <small>148</small>	ñ <small>164</small>	ł̇ <small>180</small>	- <small>196</small>	ì <small>212</small>	Σ <small>228</small>	” <small>244</small>
5	à <small>133</small>	ò <small>149</small>	Ñ <small>165</small>	Ą̇ <small>181</small>	† <small>197</small>	š <small>213</small>	σ <small>229</small>	“ <small>245</small>
6	ă <small>134</small>	û <small>150</small>	a <small>166</small>	č̇ <small>182</small>	Ų <small>198</small>	ų <small>214</small>	μ <small>230</small>	÷ <small>246</small>
7	ç <small>135</small>	ù <small>151</small>	o <small>167</small>	Ę̇ <small>183</small>	Ū <small>199</small>	ū <small>215</small>	τ <small>231</small>	≈ <small>247</small>
8	ê <small>136</small>	ÿ <small>152</small>	č̇ <small>168</small>	É̇ <small>184</small>	Ł̇ <small>200</small>	ž <small>216</small>	φ <small>232</small>	° <small>248</small>
9	ë <small>137</small>	ö̇ <small>153</small>	ƒ̇ <small>169</small>	ł̇ <small>185</small>	Ł̇ <small>201</small>	ĵ <small>217</small>	θ <small>233</small>	• <small>249</small>
A	è <small>138</small>	Ü <small>154</small>	ƒ̇ <small>170</small>	ll̇ <small>186</small>	Ł̇ <small>202</small>	ŗ <small>218</small>	Ω <small>234</small>	· <small>250</small>
B	ï <small>139</small>	ϕ <small>155</small>	½ <small>171</small>	ł̇ <small>187</small>	Ł̇ <small>203</small>	■ <small>219</small>	δ <small>235</small>	√ <small>251</small>
C	î <small>140</small>	£ <small>156</small>	¼ <small>172</small>	ł̇ <small>188</small>	Ł̇ <small>204</small>	■ <small>220</small>	ω <small>236</small>	n <small>252</small>
D	ì <small>141</small>	¥ <small>157</small>	ı̇ <small>173</small>	ł̇ <small>189</small>	= <small>205</small>	l̇ <small>221</small>	φ <small>237</small>	² <small>253</small>
E	Ä̇ <small>142</small>	℞ <small>158</small>	« <small>174</small>	ṧ <small>190</small>	Ł̇ <small>206</small>	l̇ <small>222</small>	ε <small>238</small>	■ <small>254</small>
F	Å̇ <small>143</small>	ḟ <small>159</small>	» <small>175</small>	ł̇ <small>191</small>	ž̇ <small>207</small>	■ <small>223</small>	∩ <small>239</small>	SP <small>255</small>

Page 43 (PC1119: Lithuanian)

HEX	8	9	A	B	C	D	E	F
0	Ą <small>128</small>	Ą <small>144</small>	ą <small>160</small>	Ą <small>176</small>	Ĺ <small>192</small>	ą <small>208</small>	ą <small>224</small>	ė <small>240</small>
1	Б <small>129</small>	С <small>145</small>	б <small>161</small>	Б <small>177</small>	Ľ <small>193</small>	č <small>209</small>	с <small>225</small>	ė <small>241</small>
2	В <small>130</small>	Т <small>146</small>	в <small>162</small>	В <small>178</small>	Т <small>194</small>	ę <small>210</small>	т <small>226</small>	≥ <small>242</small>
3	Г <small>131</small>	У <small>147</small>	г <small>163</small>	Г <small>179</small>	Т <small>195</small>	ė <small>211</small>	у <small>227</small>	≤ <small>243</small>
4	Д <small>132</small>	Ф <small>148</small>	д <small>164</small>	Д <small>180</small>	– <small>196</small>	į <small>212</small>	ф <small>228</small>	” <small>244</small>
5	Е <small>133</small>	Х <small>149</small>	е <small>165</small>	Ą <small>181</small>	† <small>197</small>	š <small>213</small>	х <small>229</small>	“ <small>245</small>
6	Ж <small>134</small>	Ц <small>150</small>	ж <small>166</small>	Č <small>182</small>	У <small>198</small>	ų <small>214</small>	ц <small>230</small>	÷ <small>246</small>
7	З <small>135</small>	Ч <small>151</small>	з <small>167</small>	Ę <small>183</small>	Ū <small>199</small>	ū <small>215</small>	ч <small>231</small>	≈ <small>247</small>
8	И <small>136</small>	Ш <small>152</small>	и <small>168</small>	Ė <small>184</small>	Ц <small>200</small>	ž <small>216</small>	ш <small>232</small>	° <small>248</small>
9	Й <small>137</small>	Щ <small>153</small>	й <small>169</small>	Į <small>185</small>	Г <small>201</small>	Ј <small>217</small>	щ <small>233</small>	• <small>249</small>
A	К <small>138</small>	Ь <small>154</small>	к <small>170</small>	І <small>186</small>	Ц <small>202</small>	Г <small>218</small>	ь <small>234</small>	• <small>250</small>
B	Л <small>139</small>	Ы <small>155</small>	л <small>171</small>	П <small>187</small>	П <small>203</small>	■ <small>219</small>	ы <small>235</small>	√ <small>251</small>
C	М <small>140</small>	Ь <small>156</small>	м <small>172</small>	Д <small>188</small>	П <small>204</small>	■ <small>220</small>	ь <small>236</small>	n <small>252</small>
D	Н <small>141</small>	Э <small>157</small>	н <small>173</small>	Į <small>189</small>	= <small>205</small>	І <small>221</small>	э <small>237</small>	² <small>253</small>
E	О <small>142</small>	Ю <small>158</small>	о <small>174</small>	Š <small>190</small>	† <small>206</small>	І <small>222</small>	ю <small>238</small>	■ <small>254</small>
F	П <small>143</small>	Я <small>159</small>	п <small>175</small>	Г <small>191</small>	Ž <small>207</small>	■ <small>223</small>	я <small>239</small>	SP <small>255</small>

HEX	8	9	A	B	C	D	E	F
0	А <small>128</small>	Р <small>144</small>	а <small>160</small>	⌘ <small>176</small>	Л <small>192</small>	л <small>208</small>	р <small>224</small>	Є <small>240</small>
1	Б <small>129</small>	С <small>145</small>	б <small>161</small>	⌘ <small>177</small>	Л <small>193</small>	л <small>209</small>	с <small>225</small>	є <small>241</small>
2	В <small>130</small>	Т <small>146</small>	в <small>162</small>	⌘ <small>178</small>	Т <small>194</small>	т <small>210</small>	т <small>226</small>	Г <small>242</small>
3	Г <small>131</small>	У <small>147</small>	г <small>163</small>	І <small>179</small>	І <small>195</small>	л <small>211</small>	у <small>227</small>	г <small>243</small>
4	Д <small>132</small>	Ф <small>148</small>	д <small>164</small>	І <small>180</small>	— <small>196</small>	Е <small>212</small>	ф <small>228</small>	Є <small>244</small>
5	Е <small>133</small>	Х <small>149</small>	е <small>165</small>	І <small>181</small>	† <small>197</small>	Г <small>213</small>	х <small>229</small>	є <small>245</small>
6	Ж <small>134</small>	Ц <small>150</small>	ж <small>166</small>	ІІ <small>182</small>	† <small>198</small>	П <small>214</small>	ц <small>230</small>	І <small>246</small>
7	З <small>135</small>	Ч <small>151</small>	з <small>167</small>	ІІІ <small>183</small>	† <small>199</small>	† <small>215</small>	ч <small>231</small>	і <small>247</small>
8	И <small>136</small>	Ш <small>152</small>	и <small>168</small>	ІІІІ <small>184</small>	Ц <small>200</small>	† <small>216</small>	ш <small>232</small>	ї <small>248</small>
9	Й <small>137</small>	Щ <small>153</small>	й <small>169</small>	ІІІІІ <small>185</small>	Г <small>201</small>	Ј <small>217</small>	щ <small>233</small>	ї <small>249</small>
A	К <small>138</small>	Ь <small>154</small>	к <small>170</small>	ІІІІІІ <small>186</small>	л <small>202</small>	Г <small>218</small>	ь <small>234</small>	÷ <small>250</small>
B	Л <small>139</small>	Ы <small>155</small>	л <small>171</small>	ІІІІІІІ <small>187</small>	л <small>203</small>	■ <small>219</small>	ы <small>235</small>	± <small>251</small>
C	М <small>140</small>	Ь <small>156</small>	м <small>172</small>	ІІІІІІІІ <small>188</small>	ІІ <small>204</small>	■ <small>220</small>	ь <small>236</small>	№ <small>252</small>
D	Н <small>141</small>	Э <small>157</small>	н <small>173</small>	ІІІІІІІІІ <small>189</small>	= <small>205</small>	І <small>221</small>	э <small>237</small>	¤ <small>253</small>
E	О <small>142</small>	Ю <small>158</small>	о <small>174</small>	ІІІІІІІІІІ <small>190</small>	† <small>206</small>	І <small>222</small>	ю <small>238</small>	■ <small>254</small>
F	П <small>143</small>	Я <small>159</small>	п <small>175</small>	ІІІІІІІІІІІ <small>191</small>	л <small>207</small>	■ <small>223</small>	я <small>239</small>	SP <small>255</small>

Page 45 (WPC1250: Latin 2)

HEX	8	9	A	B	C	D	E	F
0	€ 128	SP 144	SP 160	° 176	Ř 192	Ð 208	ř 224	đ 240
1	SP 129	‘ 145	˘ 161	± 177	Á 193	Ń 209	á 225	ń 241
2	, 130	, 146	˘ 162	˘ 178	Â 194	Ň 210	â 226	ň 242
3	SP 131	“ 147	Ł 163	ł 179	Ǻ 195	Ó 211	ǻ 227	ó 243
4	” 132	” 148	ł 164	˘ 180	Ǻ 196	Ô 212	ǻ 228	ô 244
5	… 133	• 149	À 165	μ 181	Ĺ 197	Õ 213	Í 229	õ 245
6	† 134	- 150	ı 166	¶ 182	Ć 198	Ö 214	ć 230	ö 246
7	‡ 135	- 151	§ 167	• 183	Ç 199	× 215	ç 231	÷ 247
8	SP 136	SP 152	“ 168	˘ 184	Č 200	Ř 216	č 232	ř 248
9	‰ 137	™ 153	© 169	ą 185	É 201	Û 217	é 233	û 249
A	Š 138	š 154	Ş 170	ş 186	Ę 202	Ú 218	ę 234	ú 250
B	‹ 139	› 155	« 171	» 187	Ě 203	Ů 219	ě 235	ů 251
C	Ś 140	ś 156	˘ 172	Ľ 188	Ě 204	Ü 220	ě 236	ü 252
D	Ÿ 141	ÿ 157	- 173	˘ 189	Í 205	Ý 221	í 237	ý 253
E	Ž 142	ž 158	® 174	ř 190	Î 206	Ï 222	î 238	ț 254
F	Ž 143	ž 159	Ž 175	ž 191	Ď 207	ß 223	ď 239	˘ 255

HEX	8	9	A	B	C	D	E	F
0	ћ 128	ћ 144	SP 160	° 176	А 192	Р 208	а 224	р 240
1	ѓ 129	‘ 145	ђ 161	± 177	Б 193	С 209	б 225	с 241
2	’ 130	’ 146	ђ 162	І 178	В 194	Т 210	в 226	т 242
3	ѓ 131	“ 147	Ј 163	і 179	Г 195	У 211	г 227	у 243
4	” 132	” 148	ѧ 164	г 180	Д 196	Ф 212	д 228	ф 244
5	… 133	• 149	Г 165	ц 181	Е 197	Х 213	е 229	х 245
6	† 134	- 150	і 166	п 182	Ж 198	Ц 214	ж 230	ц 246
7	‡ 135	- 151	§ 167	• 183	З 199	Ч 215	з 231	ч 247
8	€ 136	SP 152	Ё 168	ё 184	И 200	Ш 216	и 232	ш 248
9	‰ 137	™ 153	© 169	№ 185	Й 201	Щ 217	й 233	щ 249
A	љ 138	љ 154	Є 170	є 186	К 202	Ъ 218	к 234	ъ 250
B	‹ 139	› 155	« 171	» 187	Л 203	Ы 219	л 235	ы 251
C	ћ 140	ћ 156	¬ 172	ј 188	М 204	Ь 220	м 236	ь 252
D	ќ 141	ќ 157	- 173	ѕ 189	Н 205	Э 221	н 237	э 253
E	ћ 142	ћ 158	® 174	ѕ 190	О 206	Ю 222	о 238	ю 254
F	џ 143	џ 159	ї 175	ї 191	П 207	Я 223	п 239	я 255

Page 47 (WPC1253: Greek)

HEX	8	9	A	B	C	D	E	F
0	€ 128	SP 144	SP 160	° 176	ï 192	Π 208	Û 224	π 240
1	SP 129	‘ 145	“ 161	± 177	Α 193	Ρ 209	α 225	ρ 241
2	, 130	’ 146	À 162	² 178	Β 194	SP 210	β 226	ς 242
3	f 131	“ 147	£ 163	³ 179	Γ 195	Σ 211	γ 227	σ 243
4	” 132	” 148	α 164	´ 180	Δ 196	Τ 212	δ 228	τ 244
5	… 133	• 149	¥ 165	μ 181	Ε 197	Υ 213	ε 229	υ 245
6	† 134	- 150	¡ 166	¶ 182	Ζ 198	Φ 214	ζ 230	φ 246
7	‡ 135	- 151	§ 167	· 183	Η 199	Χ 215	η 231	χ 247
8	SP 136	SP 152	“ 168	Έ 184	Θ 200	Ψ 216	θ 232	ψ 248
9	‰ 137	™ 153	© 169	Η 185	Ι 201	Ω 217	ι 233	ω 249
A	SP 138	SP 154	α 170	Ϊ 186	Κ 202	Ϊ 218	κ 234	ϊ 250
B	< 139	> 155	« 171	» 187	Λ 203	ÿ 219	λ 235	ÿ 251
C	SP 140	SP 156	¬ 172	ο 188	Μ 204	ά 220	μ 236	ό 252
D	SP 141	SP 157	- 173	½ 189	Ν 205	έ 221	ν 237	ύ 253
E	SP 142	SP 158	® 174	Υ 190	Ξ 206	ή 222	ξ 238	ώ 254
F	SP 143	SP 159	- 175	ϙ 191	Ο 207	ί 223	ο 239	SP 255

HEX	8	9	A	B	C	D	E	F
0	€ 128	SP 144	SP 160	° 176	Â 192	Ğ 208	à 224	ğ 240
1	SP 129	‘ 145	ı 161	± 177	Á 193	Ñ 209	á 225	ñ 241
2	, 130	’ 146	¢ 162	² 178	Â 194	Ò 210	â 226	ò 242
3	f 131	“ 147	£ 163	³ 179	Ã 195	Ó 211	ã 227	ó 243
4	” 132	” 148	¤ 164	´ 180	Ä 196	Ô 212	ä 228	ô 244
5	… 133	• 149	¥ 165	µ 181	Å 197	Õ 213	å 229	õ 245
6	† 134	- 150	ı 166	¶ 182	Æ 198	Ö 214	æ 230	ö 246
7	‡ 135	- 151	§ 167	· 183	Ç 199	× 215	ç 231	÷ 247
8	^ 136	~ 152	¨ 168	¸ 184	È 200	Ø 216	è 232	ø 248
9	‰ 137	™ 153	© 169	¹ 185	É 201	Ù 217	é 233	ù 249
A	Š 138	š 154	ª 170	º 186	Ê 202	Ú 218	ê 234	ú 250
B	‹ 139	› 155	« 171	» 187	Ë 203	Û 219	ë 235	û 251
C	Œ 140	œ 156	¬ 172	¼ 188	Ì 204	Ü 220	ì 236	ü 252
D	SP 141	SP 157	- 173	½ 189	Í 205	İ 221	í 237	ı 253
E	SP 142	SP 158	® 174	¾ 190	Î 206	Ş 222	î 238	ş 254
F	SP 143	ÿ 159	- 175	¿ 191	Ï 207	ß 223	ï 239	ÿ 255

Page 49 (WPC1255: Hebrew)

HEX	8	9	A	B	C	D	E	F
0	€ 128	SP 144	SP 160	° 176	· 192	। 208	א 224	י 240
1	SP 129	‘ 145	י 161	‡ 177	… 193	· 209	כ 225	ז 241
2	’ 130	’ 146	¢ 162	2 178	… 194	· 210	ל 226	ח 242
3	f 131	“ 147	£ 163	3 179	… 195	· 211	מ 227	ט 243
4	” 132	” 148	¥ 164	ˆ 180	· 196	ן 212	נ 228	פ 244
5	… 133	• 149	¥ 165	μ 181	… 197	ן 213	ס 229	צ 245
6	† 134	- 150	ı 166	¶ 182	· 198	” 214	ת 230	ק 246
7	‡ 135	- 151	§ 167	· 183	- 199	’ 215	ך 231	ר 247
8	^ 136	~ 152	¨ 168	˙ 184	· 200	” 216	ש 232	ך 248
9	‰ 137	™ 153	© 169	1 185	· 201	SP 217	י 233	ש 249
A	SP 138	SP 154	× 170	÷ 186	SP 202	SP 218	ך 234	ן 250
B	‹ 139	› 155	« 171	» 187	· 203	SP 219	ן 235	SP 251
C	SP 140	SP 156	¬ 172	$\frac{1}{4}$ 188	· 204	SP 220	ך 236	SP 252
D	SP 141	SP 157	- 173	$\frac{1}{2}$ 189	· 205	SP 221	ן 237	SP 253
E	SP 142	SP 158	® 174	$\frac{3}{4}$ 190	- 206	SP 222	ן 238	SP 254
F	SP 143	SP 159	- 175	¿ 191	- 207	SP 223	ל 239	SP 255

HEX	8	9	A	B	C	D	E	F
0	€ 128	ك 144	SP 160	° 176	^ 192	ذ 208	à 224	” 240
1	پ 129	‘ 145	‘ 161	± 177	ء 193	ر 209	ل 225	” 241
2	، 130	’ 146	¢ 162	² 178	آ 194	ز 210	â 226	≈ 242
3	f 131	“ 147	£ 163	³ 179	أ 195	س 211	م 227	´ 243
4	” 132	” 148	¤ 164	´ 180	ؤ 196	ش 212	ن 228	ô 244
5	… 133	• 149	¥ 165	μ 181	ل 197	ص 213	ه 229	´ 245
6	† 134	- 150	¡ 166	¶ 182	ئ 198	ض 214	و 230	˘ 246
7	‡ 135	- 151	§ 167	• 183	ا 199	x 215	ç 231	÷ 247
8	^ 136	ك 152	¨ 168	˘ 184	ب 200	ط 216	è 232	” 248
9	‰ 137	™ 153	© 169	¹ 185	ة 201	ظ 217	é 233	ù 249
A	ث 138	ط 154	ه 170	؛ 186	ت 202	ع 218	ê 234	° 250
B	< 139	> 155	« 171	» 187	ث 203	غ 219	ë 235	û 251
C	£ 140	œ 156	¬ 172	$\frac{1}{4}$ 188	ج 204	ا 220	ى 236	ü 252
D	چ 141	SP 157	- 173	$\frac{1}{2}$ 189	ح 205	ف 221	ي 237	SP 253
E	ژ 142	SP 158	® 174	$\frac{3}{4}$ 190	خ 206	ق 222	î 238	SP 254
F	ڈ 143	ں 159	- 175	? 191	د 207	ك 223	ï 239	é 255

Page 51 (WPC1257: Baltic Rim)

HEX	8	9	A	B	C	D	E	F
0	€ 128	SP 144	SP 160	° 176	À 192	Š 208	ą 224	š 240
1	SP 129	‘ 145	SP 161	± 177	Ā 193	Ń 209	į 225	ń 241
2	, 130	’ 146	¢ 162	² 178	Ā 194	Ń 210	ā 226	ņ 242
3	SP 131	“ 147	£ 163	³ 179	Ć 195	Ó 211	ć 227	ó 243
4	” 132	” 148	¤ 164	´ 180	Ä 196	Ō 212	ä 228	ō 244
5	… 133	• 149	SP 165	μ 181	Å 197	Õ 213	å 229	õ 245
6	† 134	- 150	ı 166	¶ 182	Ę 198	Ö 214	ę 230	ö 246
7	‡ 135	- 151	§ 167	· 183	Ē 199	× 215	ē 231	÷ 247
8	SP 136	SP 152	Ø 168	ø 184	Č 200	Ů 216	č 232	ů 248
9	‰ 137	™ 153	© 169	¹ 185	É 201	ł 217	é 233	ł 249
A	SP 138	SP 154	Ŕ 170	ŗ 186	Ž 202	Ś 218	ż 234	ś 250
B	‹ 139	› 155	« 171	» 187	È 203	Ū 219	è 235	ū 251
C	SP 140	SP 156	¬ 172	¼ 188	Ĝ 204	Ü 220	ğ 236	ü 252
D	¨ 141	- 157	- 173	½ 189	Ķ 205	Ž 221	ķ 237	ž 253
E	˘ 142	• 158	® 174	¾ 190	Ī 206	Ž 222	ī 238	ž 254
F	˙ 143	SP 159	Æ 175	æ 191	Ł 207	ß 223	ł 239	· 255

HEX	8	9	A	B	C	D	E	F
0	€ 128	SP 144	SP 160	° 176	À 192	Ð 208	à 224	đ 240
1	SP 129	‘ 145	ì 161	± 177	Á 193	Ñ 209	á 225	ñ 241
2	, 130	’ 146	¢ 162	² 178	Â 194	” 210	â 226	· 242
3	f 131	“ 147	£ 163	³ 179	Ă 195	Ó 211	ă 227	ó 243
4	” 132	” 148	¤ 164	´ 180	Ä 196	Ô 212	ä 228	ô 244
5	… 133	• 149	¥ 165	µ 181	Å 197	Õ 213	å 229	õ 245
6	† 134	- 150	ï 166	¶ 182	Æ 198	Ö 214	æ 230	ö 246
7	‡ 135	- 151	§ 167	· 183	Ç 199	× 215	ç 231	÷ 247
8	^ 136	~ 152	¨ 168	¸ 184	È 200	Ø 216	è 232	ø 248
9	‰ 137	™ 153	© 169	¹ 185	É 201	Ù 217	é 233	ù 249
A	SP 138	SP 154	à 170	º 186	Ê 202	Ú 218	ê 234	ú 250
B	< 139	> 155	« 171	» 187	Ë 203	Û 219	ë 235	û 251
C	Œ 140	œ 156	¬ 172	¼ 188	̀ 204	Ü 220	´ 236	ü 252
D	SP 141	SP 157	- 173	½ 189	Í 205	Ư 221	í 237	ư 253
E	SP 142	SP 158	® 174	¾ 190	Î 206	˜ 222	î 238	đ 254
F	SP 143	ÿ 159	- 175	¿ 191	Ï 207	ß 223	ï 239	ÿ 255

Page 53 (KZ1048: Kazakhstan)

HEX	8	9	A	B	C	D	E	F
0	Һ <small>128</small>	һ <small>144</small>	SP <small>160</small>	° <small>176</small>	А <small>192</small>	Р <small>208</small>	а <small>224</small>	р <small>240</small>
1	Ғ <small>129</small>	‘ <small>145</small>	Ұ <small>161</small>	± <small>177</small>	Б <small>193</small>	С <small>209</small>	б <small>225</small>	с <small>241</small>
2	’ <small>130</small>	’ <small>146</small>	Ұ <small>162</small>	І <small>178</small>	В <small>194</small>	Т <small>210</small>	в <small>226</small>	т <small>242</small>
3	Ғ <small>131</small>	“ <small>147</small>	Ә <small>163</small>	і <small>179</small>	Г <small>195</small>	У <small>211</small>	г <small>227</small>	у <small>243</small>
4	” <small>132</small>	” <small>148</small>	Ҙ <small>164</small>	ө <small>180</small>	Д <small>196</small>	Ф <small>212</small>	д <small>228</small>	ф <small>244</small>
5	… <small>133</small>	• <small>149</small>	Ө <small>165</small>	ү <small>181</small>	Е <small>197</small>	Х <small>213</small>	е <small>229</small>	х <small>245</small>
6	† <small>134</small>	- <small>150</small>	і <small>166</small>	җ <small>182</small>	Ж <small>198</small>	Ц <small>214</small>	ж <small>230</small>	ц <small>246</small>
7	‡ <small>135</small>	- <small>151</small>	§ <small>167</small>	• <small>183</small>	З <small>199</small>	Ч <small>215</small>	з <small>231</small>	ч <small>247</small>
8	€ <small>136</small>	SP <small>152</small>	Ё <small>168</small>	ё <small>184</small>	И <small>200</small>	Ш <small>216</small>	и <small>232</small>	ш <small>248</small>
9	‰ <small>137</small>	™ <small>153</small>	© <small>169</small>	№ <small>185</small>	Й <small>201</small>	Щ <small>217</small>	й <small>233</small>	щ <small>249</small>
A	Љ <small>138</small>	љ <small>154</small>	Ғ <small>170</small>	Ғ <small>186</small>	К <small>202</small>	Ъ <small>218</small>	к <small>234</small>	ъ <small>250</small>
B	‹ <small>139</small>	› <small>155</small>	« <small>171</small>	» <small>187</small>	Л <small>203</small>	Ы <small>219</small>	л <small>235</small>	ы <small>251</small>
C	Њ <small>140</small>	њ <small>156</small>	Ғ <small>172</small>	ә <small>188</small>	М <small>204</small>	Ь <small>220</small>	м <small>236</small>	ь <small>252</small>
D	Қ <small>141</small>	қ <small>157</small>	- <small>173</small>	Ң <small>189</small>	Н <small>205</small>	Э <small>221</small>	н <small>237</small>	э <small>253</small>
E	Һ <small>142</small>	һ <small>158</small>	® <small>174</small>	Ң <small>190</small>	О <small>206</small>	Ю <small>222</small>	о <small>238</small>	ю <small>254</small>
F	Ұ <small>143</small>	ұ <small>159</small>	Ү <small>175</small>	ү <small>191</small>	П <small>207</small>	Я <small>223</small>	п <small>239</small>	я <small>255</small>

HEX	8	9	A	B	C	D	E	F
0	SP 128	SP 144	SP 160	SP 176	SP 192	SP 208	SP 224	SP 240
1	SP 129	SP 145	SP 161	SP 177	SP 193	SP 209	SP 225	SP 241
2	SP 130	SP 146	SP 162	SP 178	SP 194	SP 210	SP 226	SP 242
3	SP 131	SP 147	SP 163	SP 179	SP 195	SP 211	SP 227	SP 243
4	SP 132	SP 148	SP 164	SP 180	SP 196	SP 212	SP 228	SP 244
5	SP 133	SP 149	SP 165	SP 181	SP 197	SP 213	SP 229	SP 245
6	SP 134	SP 150	SP 166	SP 182	SP 198	SP 214	SP 230	SP 246
7	SP 135	SP 151	SP 167	SP 183	SP 199	SP 215	SP 231	SP 247
8	SP 136	SP 152	SP 168	SP 184	SP 200	SP 216	SP 232	SP 248
9	SP 137	SP 153	SP 169	SP 185	SP 201	SP 217	SP 233	SP 249
A	SP 138	SP 154	SP 170	SP 186	SP 202	SP 218	SP 234	SP 250
B	SP 139	SP 155	SP 171	SP 187	SP 203	SP 219	SP 235	SP 251
C	SP 140	SP 156	SP 172	SP 188	SP 204	SP 220	SP 236	SP 252
D	SP 141	SP 157	SP 173	SP 189	SP 205	SP 221	SP 237	SP 253
E	SP 142	SP 158	SP 174	SP 190	SP 206	SP 222	SP 238	SP 254
F	SP 143	SP 159	SP 175	SP 191	SP 207	SP 223	SP 239	SP 255

International Character Sets

Country	ASCII code (Hex)													
	23	24	25	2A	40	5B	5C	5D	5E	60	7B	7C	7D	7E
USA	#	\$	%	*	@	[\]	^	`	{		}	~
France	#	\$	%	*	à	°	ç	§	^	`	é	ù	è	¨
Germany	#	\$	%	*	§	Ä	Ö	Ü	^	`	ä	ö	ü	ß
U.K.	£	\$	%	*	@	[\]	^	`	{		}	~
Denmark I	#	\$	%	*	@	Æ	Ø	Å	^	`	æ	ø	å	~
Sweden	#	¤	%	*	É	Ä	Ö	Å	Ü	é	ä	ö	å	ü
Italy	#	\$	%	*	@	°	\	é	^	ù	à	ò	è	ì
Spain I	Pt	\$	%	*	@	í	Ñ	¿	^	`	¨	ñ	}	~
Japan	#	\$	%	*	@	[¥]	^	`	{		}	~
Norway	#	¤	%	*	É	Æ	Ø	Å	Ü	é	æ	ø	å	ü
Denmark II	#	\$	%	*	É	Æ	Ø	Å	Ü	é	æ	ø	å	ü
Spain II	#	\$	%	*	á	í	Ñ	¿	é	`	í	ñ	ó	ú
Latin America	#	\$	%	*	á	í	Ñ	¿	é	ü	í	ñ	ó	ú
Korea	#	\$	%	*	@	[₩]	^	`	{		}	~
Slovenia/Croatia	#	\$	%	*	Ž	Š	Đ	Ć	Č	ž	š	đ	ć	č
China	#	¥	%	*	@	[\]	^	`	{		}	~
Vietnam	₫	\$	%	*	@	[\]	^	`	{		}	~
Arabia	#	\$	%	*	@	[\]	^	`	{		}	~