

EPSON

EVO TRE 32-180
EVO TRE 16-180
Maintenance Guide

Notes

No part of this publication may be reproduced, stored in a retrieval system, or transmitted in any form or by any means, electronic, mechanical, photocopying, recording, or otherwise, without the prior written permission of Seiko Epson Corporation.

No patent liability is assumed with respect to the use of the information contained herein. While every precaution has been taken in the preparation of this book, Seiko Epson Corporation assumes no responsibility for errors or omissions. Neither is any liability assumed for damages resulting from the use of the information contained herein.

Neither Seiko Epson Corporation nor its affiliates shall be liable to the purchaser of this product or third parties for damages, losses, costs, or expenses incurred by purchaser or third parties as a result of: accident, misuse, or abuse of this product or unauthorized modifications, repairs, or alterations to this product, or (excluding the U.S.) failure to strictly comply with Seiko Epson Corporation's operating and maintenance instructions.

Seiko Epson Corporation shall not be liable against any damages or problems arising from the use of any options or any consumable products other than those designated as Original Epson Products or Epson Approved Products by Seiko Epson Corporation.

NOTICE: The contents of this manual are subject to change without notice.

Trademarks

SuperPolx® is a registered trademark of Berkshire Corporation.

All other trademarks are the property of their respective owners and used for identification purpose only.

Images Used in this Manual

The images used in this document may vary from your machine. Unless otherwise stated, this document uses images of the EVO TRE 32-180.

©Seiko Epson Corporation 2020–2024

Contents

1.	Before Starting Maintenance Work.....	4
1.1.	Meaning of Symbols.....	4
1.1.1	Symbols in This Manual.....	4
1.1.2	User Permissions.....	5
1.1.3	Symbols on This Machine.....	6
1.1.4	Caution Labels.....	7
1.2.	Safety Information.....	14
1.2.1	Safety Information for Maintenance Work.....	14
1.2.2	Safety Information in Handling Consumables (Ink, Maintenance Liquid) and Waste Ink.....	15
1.2.3	Safety Precautions.....	17
1.3.	List of Maintenance Tools and Supplies.....	18
1.4.	Wearing of Personal Protective Equipment.....	20
1.5.	Checks Before Maintenance Work.....	21
2.	Ordinary scheduled maintenance suggestion.....	23
2.1.	Inspection/Cleaning.....	23
2.2.	Adjustment/Replacement.....	24
3.	Inspection/Cleaning Procedure.....	25
3.1.	Checking the Area around Operating Parts.....	25
3.2.	Checking the Amount of Waste Ink.....	26
3.3.	Inspecting the Emergency Stop Button.....	27
3.4.	Inspect the Open Cover Detection.....	27
3.5.	Inspect for Leaks in the Ink Path.....	27
3.6.	Cleaning the Area Around the Caps and Wipers.....	28
3.7.	Cleaning the Flushing Plate.....	33
3.8.	Checking the Height with the Foreign Material Detection Sensor.....	36
3.9.	Cleaning the Belt and Removing Ink Film (When Using Pigment Ink).....	38
3.9.1	Cleaning Ink Stains on the Belt.....	38
3.9.2	Removing Ink Film.....	40
3.10.	Cleaning the Area around the Head and Inspecting the Sub-tank Rack.....	44
3.11.	Cleaning the Cleaning Brushes and the Area around Them.....	57
3.12.	Cleaning the Head Cover.....	61
3.13.	Cleaning the Plate (Guide Beside the Belt).....	62
3.14.	Cleaning the Carriage Operating Parts.....	63
3.15.	Applying Grease to the Carriage Operating Parts.....	66
3.16.	Applying Grease to the Scan Spindle.....	69
3.17.	Checking for Water Leaks in the Pipe Joints.....	72
3.18.	Discharging the Compressed Air Route Regulator and Dry Air System Lubricator.....	73
3.18.1	Discharging the Compressed Air Route Regulator.....	73
3.18.2	Discharging the Dry Air System Lubricator (in Flushing Area).....	75
3.18.3	Dry Air System (DAS).....	76
3.19.	Cleaning/Replacing the Mist Filter.....	77
3.20.	Checking the Blower and Cleaning/Replacing the Filter.....	79
3.21.	Cleaning/Replacing the Cooling Fan Filters.....	81
3.21.1	Cleaning the Cooling Fan Filters.....	81
3.21.2	Replacing the Cooling Fan Filters.....	87
3.22.	Checking the Cable Protection Condition.....	92
4.	Adjustment Procedure.....	93
4.1.	Bi-directional Adjustment.....	93
4.2.	Belt Feed Amount Adjustment.....	95
5.	Replacement Procedure.....	97
5.1.	Cap Replacement.....	97
5.2.	Wiper Replacement.....	101
5.3.	Towel Roller Fabric Replacement.....	105
5.4.	Washing T-shaped Scraper Replacement.....	109
5.5.	Washing Silicone Scraper Replacement.....	114
5.6.	Pressure Roller Replacement.....	115
6.	Glue Re-Application.....	118

1. Before Starting Maintenance Work



To use the machine safely, please read the user's manual for this machine carefully before using the machine. Failure to comply with the user's manual may cause malfunctions or accidents. Store the user's manual of this machine in a location where it can be easily referred to whenever you have a question.







1.1. Meaning of Symbols

The following warning symbols are used in this manual and on this machine to indicate hazardous operations, to ensure that this machine is used safely and correctly in order to prevent injury to the user and other persons and damage to property.



Please carefully read and understand these warnings before using this machine.

1.1.1 Symbols in This Manual

 WARNING	This symbol indicates that incorrect operation could result in death or serious injury.
 CAUTION	This symbol indicates that incorrect operation could result in injury and/or damage to property.





















				
Indicates actions that must not be taken (prohibited actions).	Indicates actions that must be taken and/or instructions that must be followed.	Do not disassemble	Do not touch	No flames
				
Eye protection must be worn	Protective gloves must be worn	Protective clothing must be worn	Respiratory protection must be worn	Hair net required

1.1.2 User Permissions

	<p>This symbol indicates user permissions for general users who have been trained in the operation of the machine, to perform machine normal operation, cleaning, and simple maintenance procedures while protective devices are engaged and using the button panel.</p> <p>"L" profile to the person assigned to normal operation of the machine.</p>
	<p>This symbol indicates user permissions for general users who have been officially trained in the operation of this machine, to perform some functions and maintenance procedures that are allowed in addition to all of the functions for L.</p> <p>"H" profile to the person assigned to the periodic supervising operations, who holds the activation keys for the selectors and is authorized to occasionally operate the job controls. The user is required to acquaint the operators about the information contained in this manual and to always have the manual accessible for reference.</p> <p>The same is true for the operators assigned to checks and maintenance, both routine or extraordinary and only if qualified by specific Epson training.</p> <p>Operators are required to understand and adhere to company safety rules, general accident prevention standards, and health and safety regulations.</p> <p>It is the responsibility of the user to assign personnel to run and/or maintain the machine who are suitable both physically, mentally, and professionally for the tasks and responsibilities involved in each.</p> <p>In particular, for personal and general safety, the machine must absolutely never be operated by people with abnormal reaction times because of their intake of medicines or similar substances, or because of physical defects that slow their movements.</p> <p>It is strongly recommended to make all operators aware of their responsibilities when running the machine. For that purpose, it is also important to collect their recommendations, complaints, and suggestions, as well as all notations on any anomalies that may occur.</p>

1.1.3 Symbols on This Machine

Do not remove the warning labels that are attached to this machine. If a warning label becomes illegible or is removed, contact your dealer or Epson Support for a replacement label.

				
CAUTION: Risk of electric shock	CAUTION: High temperature	CAUTION: Risk of pinching or crushing fingers	CAUTION: Risk of hand injury	
				
CAUTION: Risk of becoming pulled into machine	CAUTION: Risk of becoming pulled into machine	CAUTION: Risk of becoming caught between parts		Do not operate without guard
				
CAUTION: Risk of damage, falling, or injury due to breakage	No pacemakers	CAUTION: Strong magnetic field	CAUTION: Watch your head	No flames
				
Do not wear scarfs/neckties	Do not clean, maintain, or repair	CAUTION: Risk of electric shock Turn off the power before opening the door	Connect an earth terminal to the ground	USB

1.1.4 Caution Labels

Labels are affixed to the machine to draw attention to dangerous locations.

Main electric box

It will look like either of the following.



Front

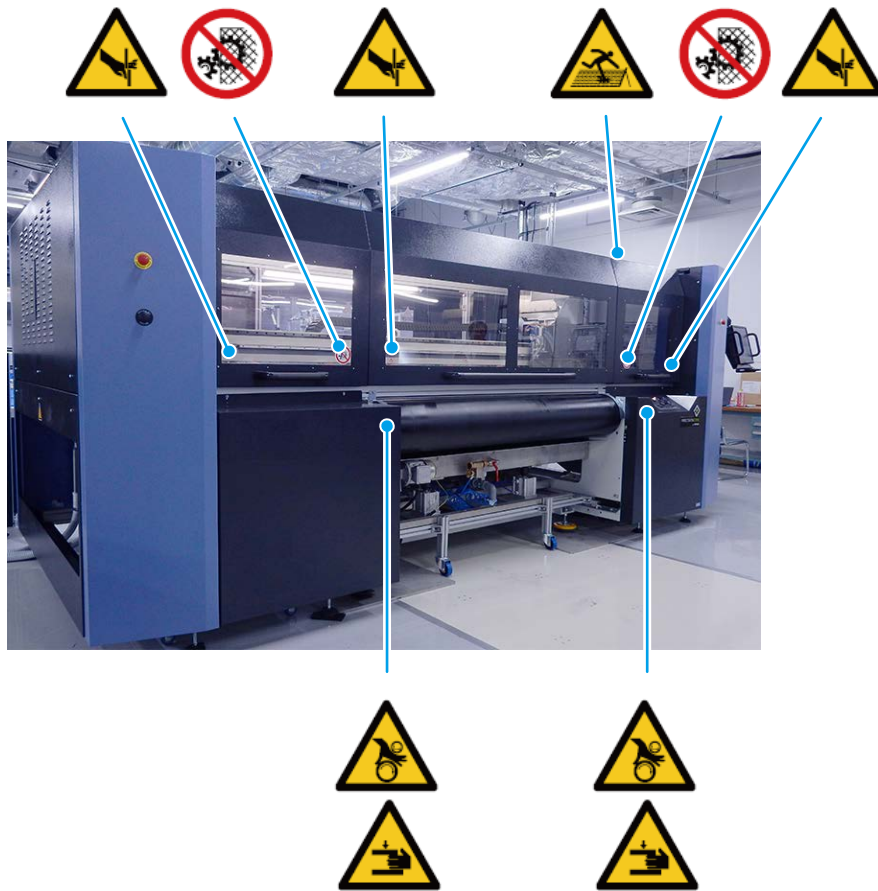

Left side

3 L ink cartridge model



10 L ink cartridge model

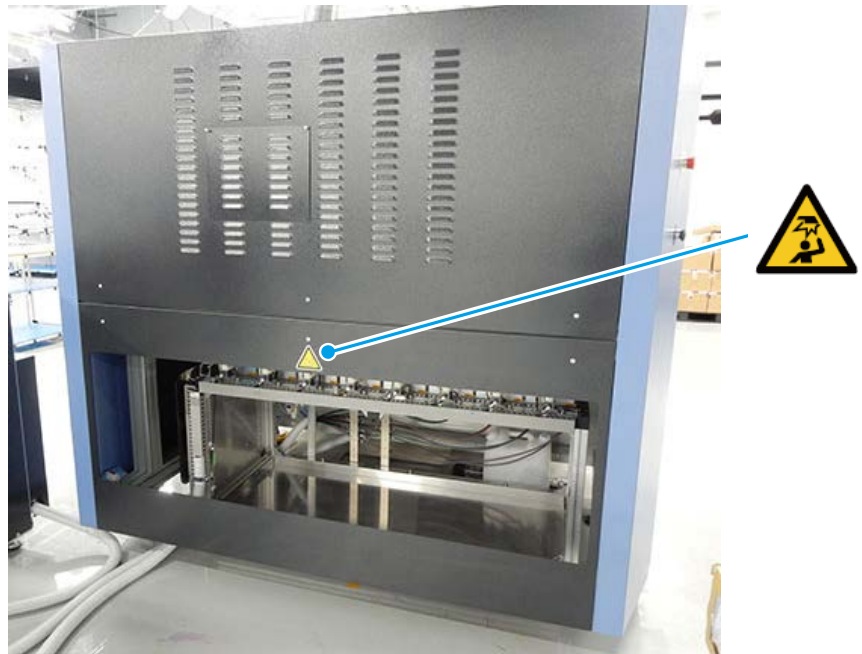

Print heads

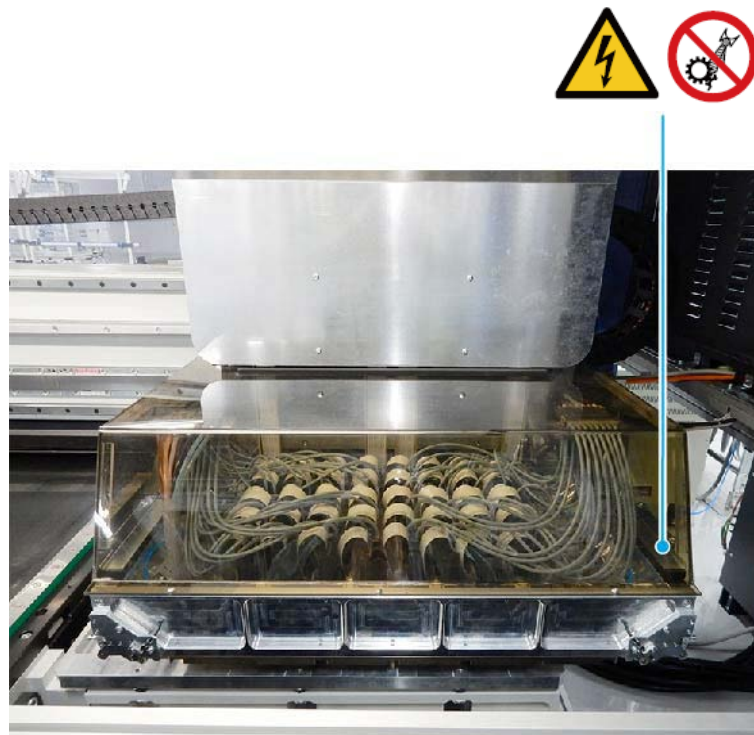

When opening the rear protection cover

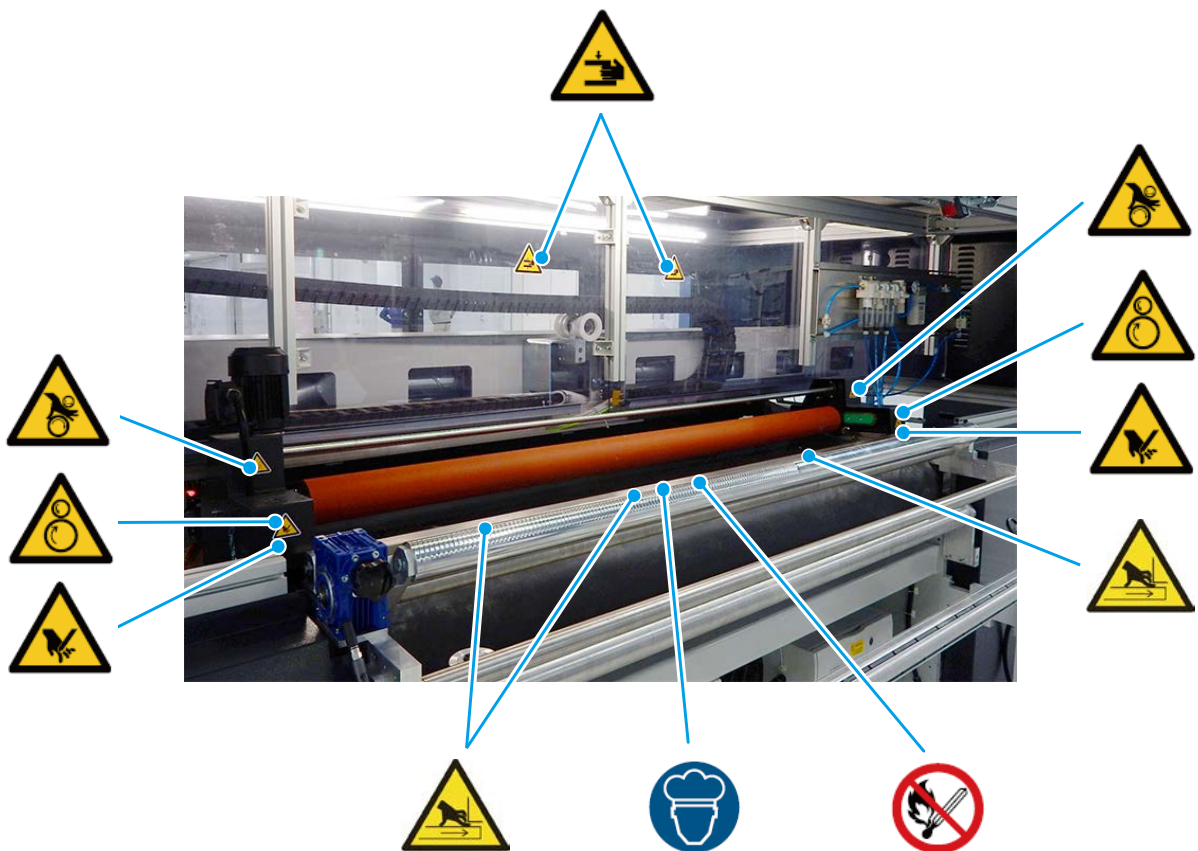

Ink rack



Left side of the Sub-tank rack

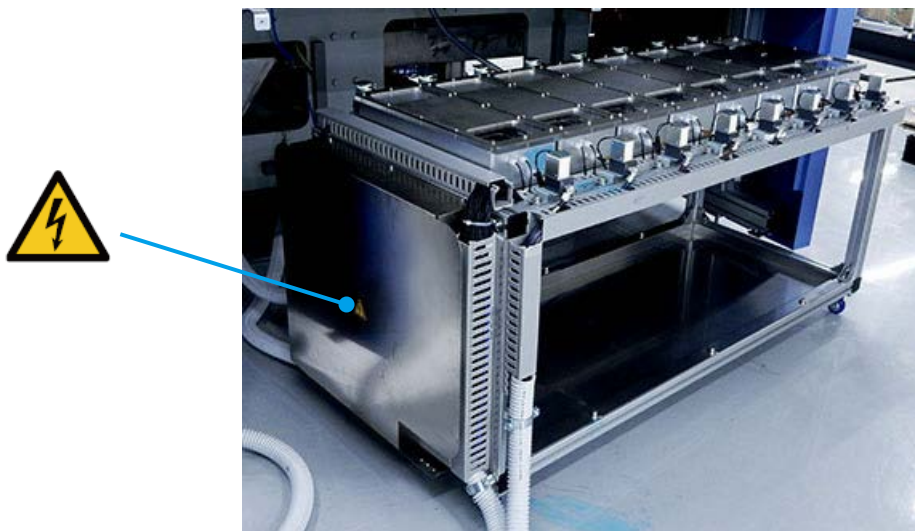

Ink tank housing (When opening the front left cover)

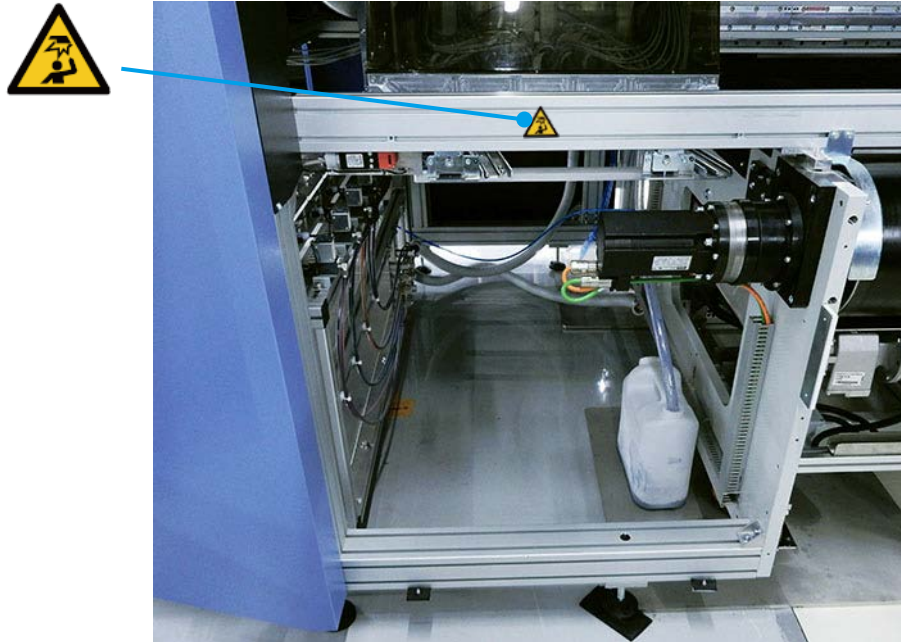

Inside of the Ink tank housing

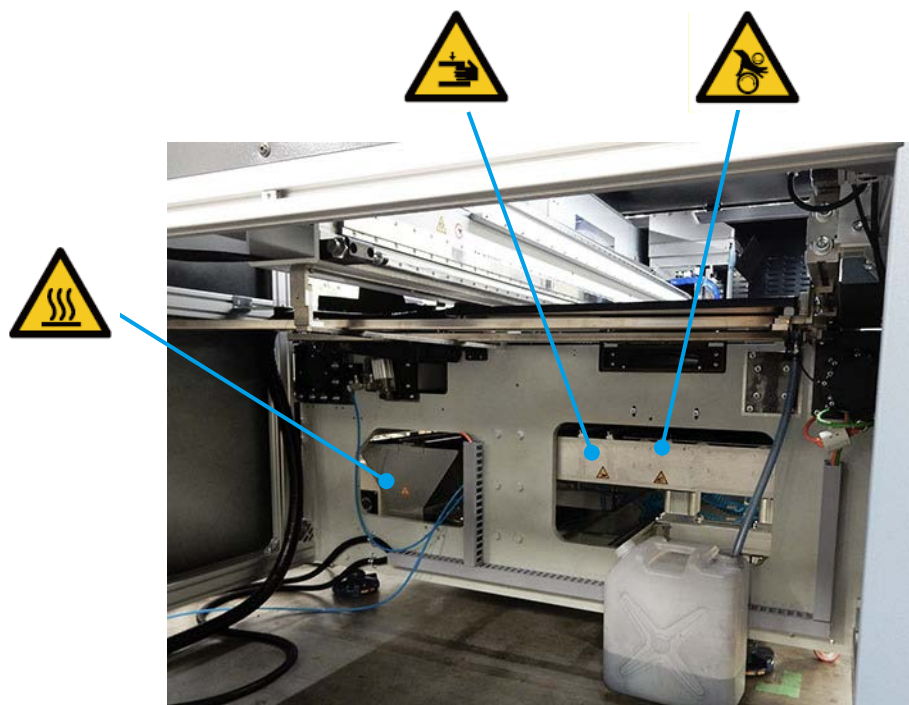



















WARNING

Manufacturer does not under any circumstances require any access inside of the machine for maintenance.
All operations can and must be carried out from the outside.





1.2. Safety Information

1.2.1 Safety Information for Maintenance Work

 WARNING	
    	<p>Do not operate this machine or the computer while maintenance is being performed.</p> <p>When performing maintenance work in a location that is out of sight of the control PC operator, make sure that only the person performing maintenance work and no one else is able to operate the control PC.</p> <p>Doing so leads to the risk of your hand or other parts of your body becoming caught in the machine.</p>
 	<p>Do not operate this machine if you have a pacemaker.</p> <p>The electromagnetic waves that are generated by this machine can affect the operation of pacemakers.</p>
 	<p>This machine generates a strong magnetic field. Do not use precision equipment such as watches and mobile phones nearby.</p> <p>Precision equipment could malfunction or become damaged by the strong magnetic field.</p>

 CAUTION	
    	<p>During maintenance work, wear all the protective equipment described in "Personal Protective Equipment" (eye protection, protective gloves, respiratory protection, etc.) in each section below. Long hair should be tied back and worn under a hair net.</p> <ul style="list-style-type: none"> • Use protective equipment compliant with the safety regulations. • Using additional protective equipment compliant with the safety regulations is recommended when necessary.
 	<p>Do not allow any person on the machine while working. Note that the machine is not designed to support the weight and can be easily damaged. When performing maintenance to parts on the upper part of the machine, use a tool, such as a step stool, appropriate for the work.</p> <p>Failure to do so could lead to injury or damage to the machine.</p>
	<p>Make sure that all maintenance work is performed at room temperature.</p>

1.2.2 Safety Information in Handling Consumables (Ink, Maintenance Liquid) and Waste Ink

 WARNING	
	<p>If fluid gets on your skin or enters your eyes or mouth, take the measures below.</p> <ul style="list-style-type: none"> • If fluid gets on your skin, rinse immediately with soap and water. • If the liquid enters your eyes, rinse immediately with water. Failure to observe this precaution could result in bloodshot eyes or mild inflammation. If problems persist, consult with a physician. • If the liquid enters your mouth, consult a physician immediately.
	<p>Do not disassemble or remodel the cartridge.</p> <p>Otherwise, the ink and/or cleaning liquid could get in your eyes or come in contact with your skin.</p>
	<p>Keep ink cartridges, maintenance liquid, cleaning liquid, scan spindle grease, waste ink, glue, remover, and ink film remover out of the reach of children.</p>



CAUTION









Be sure to wear eye protection and respiratory protection when applying or removing glue or removing ink film.





Be sure to wear protective gloves when using maintenance liquid.

1.2.3 Safety Precautions

	When maintenance work is completed, immediately return the protective equipment to its original location.
	Make sure that no tools or parts used in maintenance work, or other foreign materials are left on the operating parts of the machine or inside the machine.
	During maintenance, do not use sharpening stones, abrasive/corrosive materials, or solvents (excluding glue and ink film remover). Doing so may erase numbers, codes or characters indicated on the machine.
	Do not expose the electrical and electronic devices, and motors to liquid.
	Do not touch the micro switches on the alarm or on the front/rear protection cover.
	Use the products properly according to the "Safety Data Sheet" for each product.

1.3. List of Maintenance Tools and Supplies









Prepare the items listed below before starting inspection/cleaning.

Item	Details/Use
<p>Clean stick (Dedicated consumables/commercially available)</p> 	<p>Use for cap and wiper cleaning</p> <p>If purchasing from Epson: Item name: Clean Stick B Model no.: C13S090011</p> <p>Epson recommends the following if purchasing yourself: ASPURE from AS ONE Corporation Model no.: AP125PCT</p>
<p>Cleaning cloth (Dedicated consumables/commercially available)</p> 	<p>Nonwoven fabric for head cleaning</p> <p>If purchasing from Epson: Item name: Head Cleaning Cloth A Model no.: C13S210050</p> <p>Epson recommends the following if purchasing yourself: Berkshire Corporation SuperPolx® 1200</p>
<p>Maintenance liquid (Dedicated consumables)</p>	<p>Cleaning liquid especially for maintenance of this machine Do not dilute the liquid.</p> <p>Dedicated consumables: Item Name: Maintenance Liquid Model no.: C13T42X000</p>
<p>Grease pump (Bundled item)</p> 	<p>Used for adding grease to the scan spindle.</p>

Item	Details/Use
Grease (Commercially available)	Grease applied to the carriage operating parts and scan spindle. Epson recommends the following: NSK Ltd. Model no.: NSK GRS AS2
Plastic container (Commercially available)	Used to contain the maintenance liquid or tap water for cleaning. Epson recommends the following: Disposable cup
Rubber gloves (Commercially available)	Use during cleaning.
Eye protection (Commercially available)	Use during cleaning of the area around the head, caps, and wipers, and when replacing the head.
Plastic tweezers (Commercially available)	Use for cap cleaning
Hex key (Commercially available)	Used to fasten or loosen screws on the machine.
Spanner (width: 7 mm) (Commercially available)	Used to fasten or loosen screws on the machine.
Antistatic wrist strap (Commercially available)	Used to prevent static electricity during cleaning of the area around the head, and head replacement.
Flashlight (Commercially available)	Used when working in the ink tank housing.
Scraper/Brush (Commercially available)	Use for flushing plate cleaning
Forceps (Commercially available)	Use for cap replacement replacement Use a type that cannot damage the ink tube.
Feeler gauge (Commercially available)	Used for height check using the fabric slack detection sensor. A hex key (width: 2 mm) can be used as a substitute.
Tray (Commercially available)	Used for cleaning the cooling fan filters.



1.4. Wearing of Personal Protective Equipment

 CAUTION		
	  	<p>Be sure to wear personal protective equipment (protective gloves and clothing) during maintenance work on this machine.</p> <p>Long hair should be tied back and worn under a hair net.</p> <p>Otherwise, your hands and clothing could become stained with ink, and your fingers and hair could become caught in the machine.</p>
		<p>Be sure to wear eye protection during maintenance work on areas near the ink path, including cleaning of the area around the head, caps, and wipers, and head replacement.</p> <p>Failure to do so could cause ink to splash into the eyes.</p>
	 	<p>Be sure to wear eye protection and respiratory protection when applying or removing glue or removing ink film.</p>

1.5. Checks Before Maintenance Work

Do not place tools, fasteners, or the like on the belt or near the pressure roller or print head. Doing so could cause them to be entangled in the belt, pressure roller, or print head, damaging this machine. Before turning the power on, check that there is nothing left near the moving parts, such as on the belt or near the print head.

Front

1. Open the front protection cover of this machine.
2. Check that there are no tools, fasteners, or the like left on the belt or near the carriage or print head.

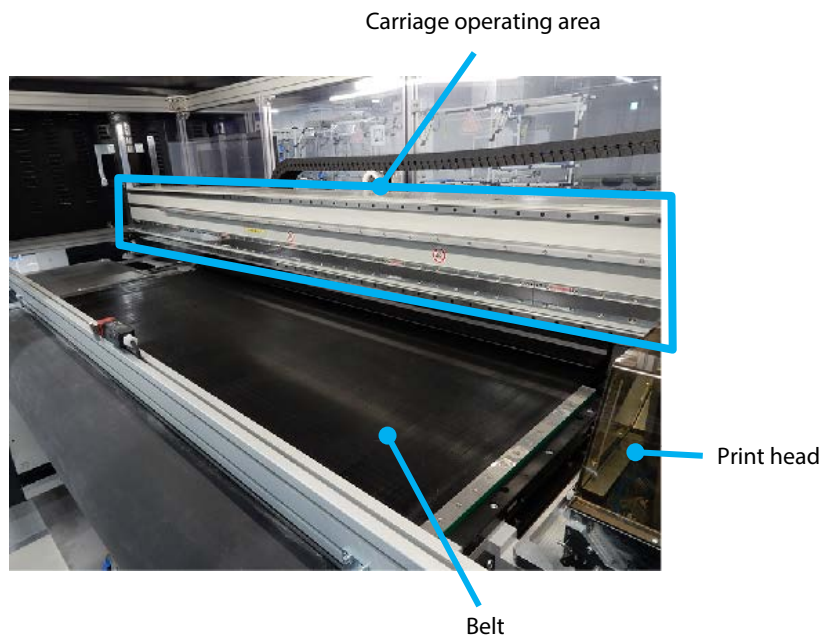

3. Close the front protection cover.

Rear

1. Open the rear protection cover of this machine.
2. Check that there are no tools, fasteners, or the like left near the belt or the pressure roller.

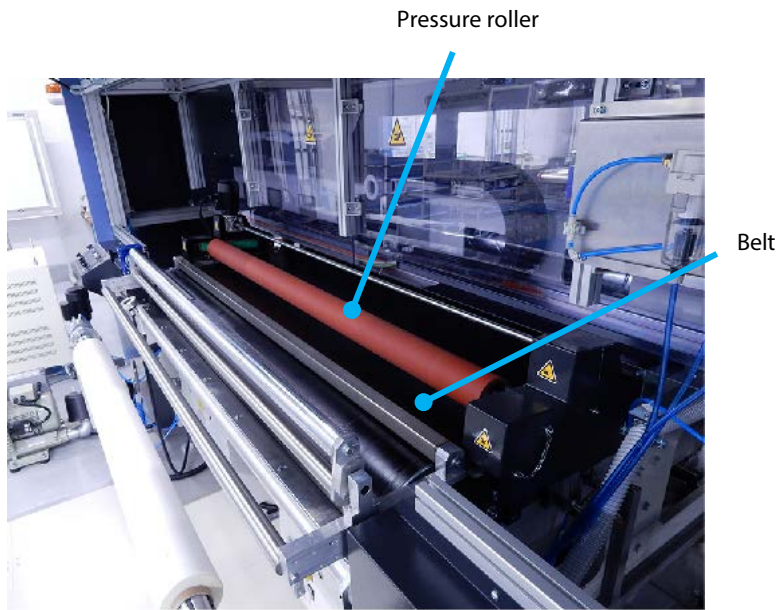

3. Close the rear protection cover.

2. Ordinary scheduled maintenance suggestion

2.1. Inspection/Cleaning

Category	Item	Inspection Frequency					User Permissions	Procedure Details	
		Every shift	Everyday	Every week	Every month	Every six months			When necessary/ When a problem occurs
Inspection/Cleaning	<input type="checkbox"/> Checking the area around operating parts	✓					L	3.1	
	<input type="checkbox"/> Checking the amount of waste ink	✓					H	3.2	
	<input type="checkbox"/> Inspecting the emergency stop button		✓				L	3.3	
	<input type="checkbox"/> Inspecting the open cover detection	✓					L	3.4	
	<input type="checkbox"/> Inspecting for leaks in the ink path		✓				L	3.5	
	<input type="checkbox"/> Cleaning the area around the caps and wipers		✓				✓	L	3.6
	<input type="checkbox"/> Cleaning the flushing plate		✓					L	3.7
	<input type="checkbox"/> Checking the height with the foreign material detection sensor	✓					✓ *2	L	3.8
	<input type="checkbox"/> Cleaning the ink stains on the belt (pigment ink)		✓					L	3.9.1
	<input type="checkbox"/> Removing the ink film on the belt (pigment ink)						✓	L	3.9.2
	<input type="checkbox"/> Cleaning the area around the head and inspecting the sub-tank rack			✓			✓	H	3.10
	<input type="checkbox"/> Cleaning the cleaning brushes and the area around them			✓			✓ *1	L	3.11
	<input type="checkbox"/> Cleaning the head cover						✓	L	3.12
	<input type="checkbox"/> Cleaning the plate (guide beside the belt)						✓	L	3.13
	<input type="checkbox"/> Cleaning the carriage operating parts				✓			L	3.14
	<input type="checkbox"/> Applying grease to the carriage operating parts					✓		H	3.15
	<input type="checkbox"/> Applying grease to the scan spindle					✓		H	3.16
	<input type="checkbox"/> Checking for water leaks in the pipe joints				✓			L	3.17
	<input type="checkbox"/> Discharging the compressed air route regulator and dry air system lubricator		✓					H	3.18
	<input type="checkbox"/> Cleaning/Replacing the mist filter				✓ Cleaning		✓ Replacement	L	3.19
	<input type="checkbox"/> Checking the blower and cleaning/replacing the filter				✓ Inspection		✓ Cleaning/ Replacement	L	3.20
	<input type="checkbox"/> Cleaning/Replacing the cooling fan filters				✓		✓	L	3.21
<input type="checkbox"/> Checking the cable protection condition				✓			L	3.22	

*1: After printing on fabric with fuzzy surface

*2: When changing the fabric type

2.2. Adjustment/Replacement

Category	Item	Inspection Frequency					User Permissions	Procedure Details
		Every shift	Everyday	Every week	Every month	Every six months		
Adjustment	<input type="checkbox"/> Bi-directional adjustment						✓ *3	H 4.1
	<input type="checkbox"/> Belt feed amount adjustment						✓ *4	H 4.2
Replacement	<input type="checkbox"/> Cap replacement						✓	L 5.1
	<input type="checkbox"/> Wiper replacement						✓	L 5.2
	<input type="checkbox"/> Towel roller fabric replacement						✓	L 5.3
	<input type="checkbox"/> Washing T-shaped Scraper Replacement						✓	L 5.4
	<input type="checkbox"/> Washing Silicone Scraper Replacement						✓	L 5.5
	<input type="checkbox"/> Pressure roller replacement						✓	L 5.6
Glue Re-Application	<input type="checkbox"/> Glue Removal						✓	H 6.1
	<input type="checkbox"/> Glue Application						✓	H 6.2

*3: When replacing heads/When changing jobs

*4: When irregular streaking occurs/When changing jobs

3. Inspection/Cleaning Procedure

3.1. Checking the Area around Operating Parts

Frequency	Every shift
User Permissions	L
Personal Protective Equipment	Protective gloves and clothing

Make sure that no tools or other items are left on operating parts such as the print head operating area [1] and the carriage operating area [2]. If any item is left, remove it.

Front



Rear



3.2. Checking the Amount of Waste Ink

Frequency	Every shift
User Permissions	
Personal Protective Equipment	Protective gloves and clothing

Check the amount of waste ink in the flushing area (1: front left side) and the cleaning station (2: front right side).
Dispose of waste ink if necessary.



3.3. Inspecting the Emergency Stop Button

Frequency	Everyday Inspection before beginning work
User Permissions	L
Personal Protective Equipment	Protective gloves and clothing

Check that the emergency stop button operates normally.
For detailed procedures, refer to the "Operation Guide".

3.4. Inspect the Open Cover Detection

Frequency	Every shift Inspection before beginning work
User Permissions	L
Personal Protective Equipment	Protective gloves and clothing

Check that the cover open detection function on the front/rear side is operating normally.
For detailed procedures, refer to the "Operation Guide".

3.5. Inspect for Leaks in the Ink Path

Frequency	Everyday
User Permissions	L
Personal Protective Equipment	Protective gloves and clothing

Check for ink leaks in each ink path. Check for ink leaks or runs around the connections between the heads and tubes, and around the print heads.
For detailed procedures, refer to the "Operation Guide".

3.6. Cleaning the Area Around the Caps and Wipers

Frequency	Everyday/When a problem occurs (When a problem such as mixed colors and nozzle clogging occurs)
User Permissions	L
Personal Protective Equipment	Protective gloves and clothing, eye protection
Required Items	Clean stick, maintenance liquid, plastic container, tweezers

	For cleaning, be sure to use the dedicated maintenance liquid.
---	--

1. Execute Set point.

On the Leonardo operation screen, click [Setpoint] and then press the reset button on the main electric panel. The head carriage returns to the origin position and moves to the cleaning station.

2. Move the head carriage to the flushing area.

On the Leonardo operation screen, open [Maintenance] (1), and click [+] (2) for [Carriage] under [Axes] once. When the head carriage moves to the center, click [+] again.

The head carriage moves to the left into the flushing area.

	Do not work for a long period of time while the head carriage is uncapped. Doing so can cause the print head nozzles to clog, causing a printing error. Pigment ink in particular causes a failure if left uncapped for 24 hours.
---	---

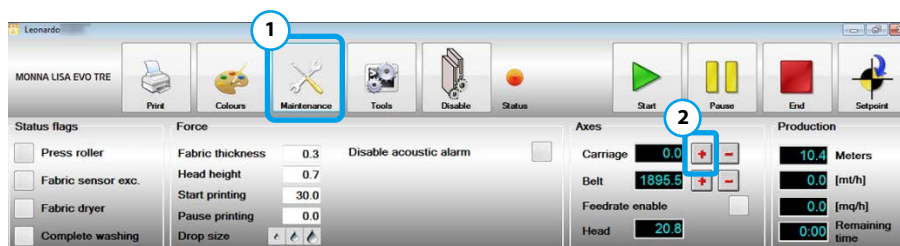

3. Press the emergency stop button.

4. Close the Leonardo screen and shut down the PC.

5. Turn the main power switch to 0 (OFF) to turn the power off.

6. Open the front protection cover.



7. Lightly wipe off dirt from around the cap using the cleaning cloth or clean stick moistened with maintenance liquid. Wipe off in the direction of the arrows.



- Do not wipe around the cap with force. Doing so may damage the lip section of the cap, deteriorate nozzle recovery by cleaning, or result in nozzle clogging.
- Do not allow the cleaning cloth or clean stick to touch the absorber or metal part in the cap. Doing so may deform the parts, resulting in damage to the head nozzle surface or nozzle clogging.

Absorber

Metal part

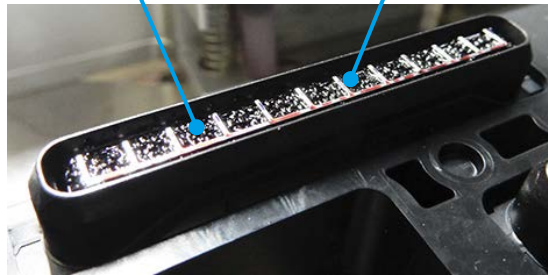

For clean stick

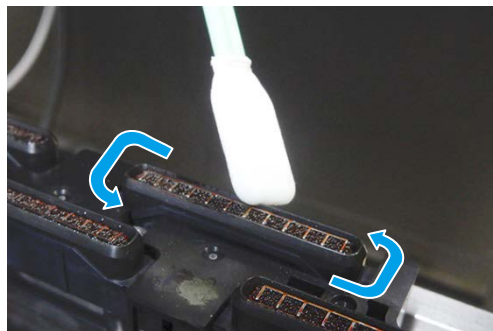

For cleaning cloth



8. Remove fluffy dust if adhering around the cap using plastic tweezers.



Do not pinch the lip section of the cap with the tweezers.
Doing so may damage the lip, leading to poor sealing.

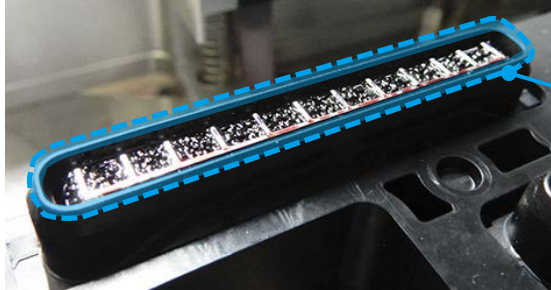

Lip section



9. Lightly wipe off dirt from around the wiper using the cleaning cloth or clean stick moistened with maintenance liquid. Wipe off in the direction of the arrows. The same applies to the cleaning cloth.



Do not pull the rubber part of the wipers.

Wiper section



Rear side of wiper

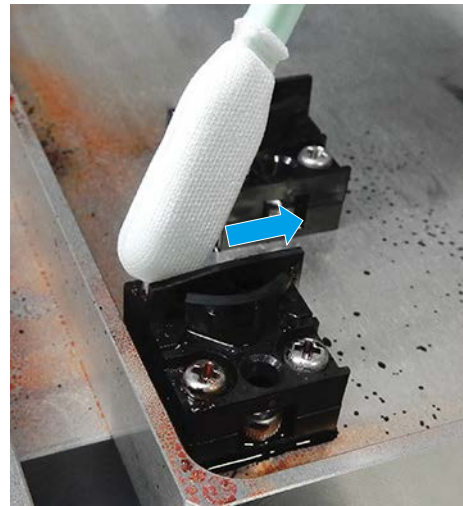

10. When cleaning is finished, close the front protection cover.
11. Turn the main power switch to 1 (ON) to turn the power on.
12. Release the emergency stop button.
13. Start up Leonardo.
14. Execute Set point.
On the Leonardo operation screen, click [Setpoint] and then press the reset button on the main electric panel. The head carriage moves to the cleaning station.

3.7. Cleaning the Flushing Plate

Frequency	Everyday, when printing ends
User Permissions	L
Personal Protective Equipment	Protective gloves and clothing, eye protection
Required Items	Clean stick, scraper/brush



CAUTION

Be sure to wear eye protection.
Failure to do so could cause ink to splash into the eyes.

Clean away any waste ink that has built up on the flushing plate.

1. Check the remaining capacity of the waste ink tank in the flushing area.
Dispose of the waste ink if there is only a little remaining capacity. (See: 3.2 Checking the Amount of Waste Ink)
2. Open the front protection cover.



3. Sweep the ink remaining on the plate into the path at the corner of the plate using the scraper.

	<p>If waste ink is dried, apply maintenance liquid to dissolve the ink before cleaning.</p>
	

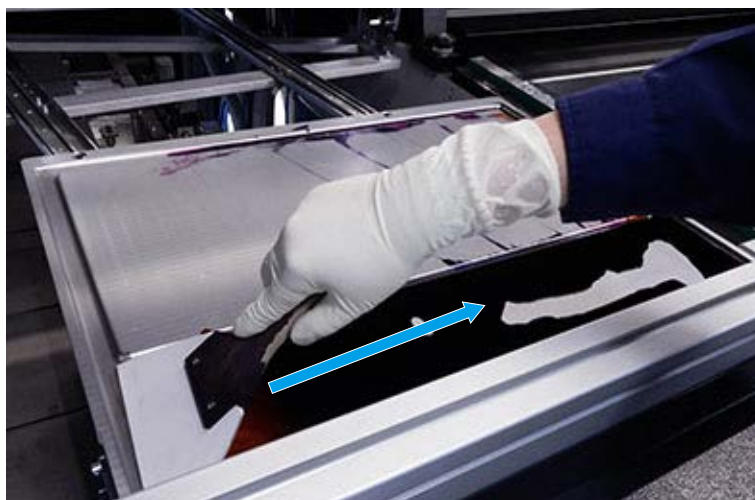

4. Discharge the waste ink collected in the path from the drain using the clean stick or brush.

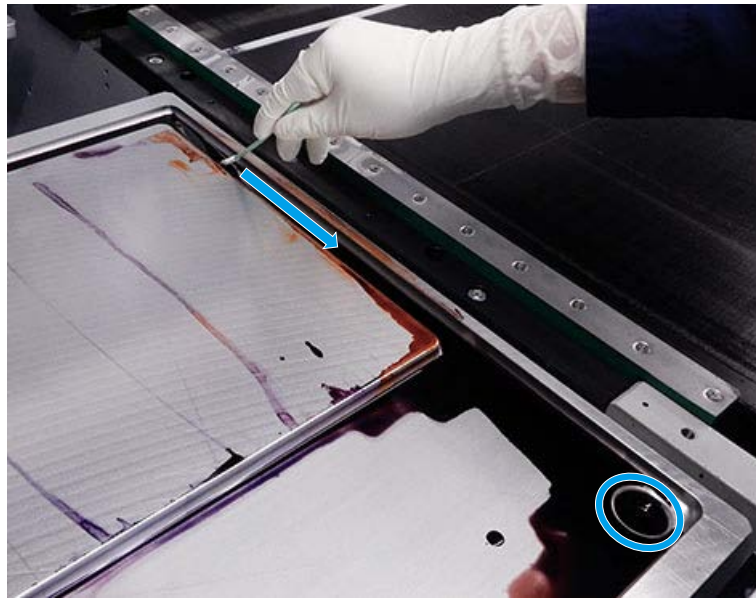

If the machine is not connected to the factory waste fluid drain, check the amount remaining in the waste ink tank.

5. When cleaning is finished, close the front protection cover.

3.8. Checking the Height with the Foreign Material Detection Sensor

Frequency	Every shift/When changing the fabric type
User Permissions	L
Personal Protective Equipment	Protective gloves and clothing
Required Items	Hex key (width: 2 mm) or feeler gauge (2 mm)

Check that the foreign material detection sensor is operating normally.

1. Before starting work, check the detection threshold value with nothing placed on the belt.
Check the foreign material detection sensor display on the front panel to confirm that the displayed value is 9,999 or higher.



2. Place the hex key (width: 2 mm) or feeler gauge (2 mm) on the front right of the belt.

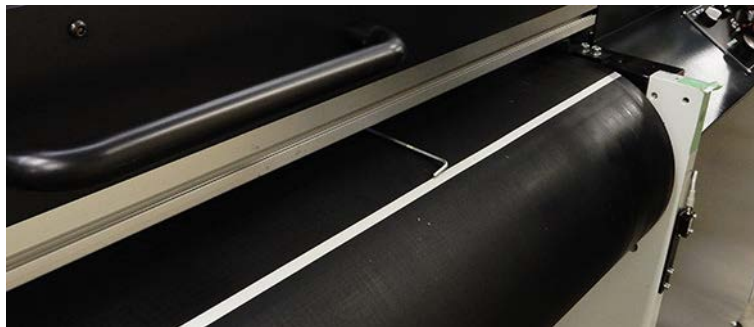

3. Feed the belt in the reverse direction to the position where the hex key or feeler gauge is exposed the sensor laser beam.

4. Move to the machine rear, and check that the tool is exposed to the laser beam through the gap at the top of the pressure roller.

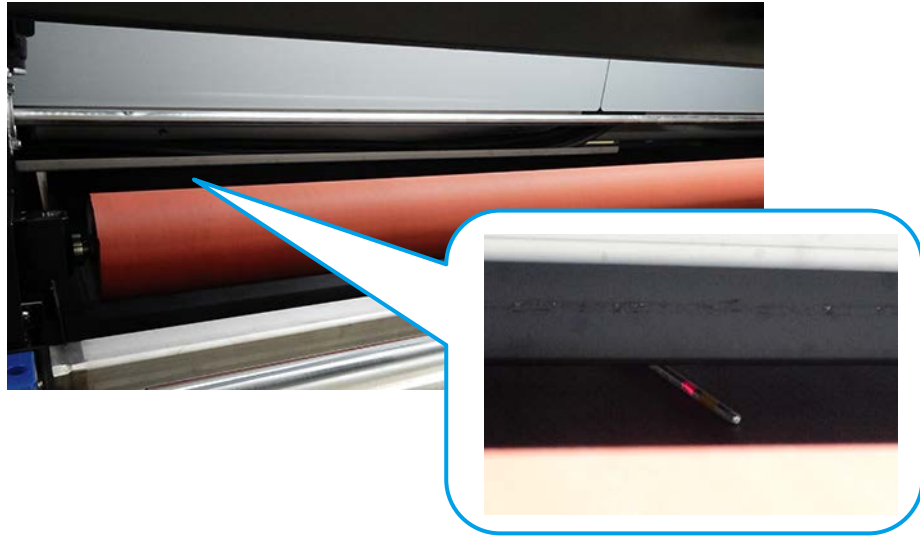





5. Check the foreign material detection sensor display again to confirm that the detection threshold value is 500 or more lower than the previous value.
6. Check on the front left side of the belt in the same way.



3.9. Cleaning the Belt and Removing Ink Film (When Using Pigment Ink)

When pigment ink adheres to the belt, an ink film is formed. When an ink film forms, the adhesive strength of the glue applied to the belt decreases and the fabric attached to the belt becomes more likely to float.

To prevent ink film, clean any pigment ink adhering to the belt. Also, if an ink film has formed on the belt, remove the ink film.

3.9.1 Cleaning Ink Stains on the Belt

Frequency	Everyday, when printing ends	
User Permissions	L	
Required Number of Workers	1 person	
Personal Protective Equipment	<p>The following is the protective equipment that must be worn when using the ethanol recommended by Epson.</p> <p>For details, refer to the instructions of the SDS for the ethanol you are actually using.</p>	
	<p>Eye protection (For organic solvent use; Optimal is a goggle-type that seals against your face)</p>	
		
	<p>Gas mask (For organic solvent use)</p>	
		
	<p>Protective gloves (Butyl or polyurethane)</p>	
		
<p>Protective clothing (Long-sleeved)</p>		
<p>Hat or hair net (Persons with long hair must be tied together with a hair net also worn)</p>		
<p>Safety shoes</p>		

Required Items			
Item	Quantity	Details/Use	
Ethanol	Approx. 0.1 L	Commercially available	Removes any ink adhering to the belt. Mix with tap water before use.
Cleaning bottle 	1	Commercially available	This container is used to hold a cleaning liquid made by mixing tap water and ethanol.
Wipe cloths 	Proper amount	Commercially available	Used to wipe the belt. Use cloths of soft non-fluffy material that will not damage the belt.

1. Put ethanol (approx. 0.1 L) and tap water (approx. 0.1 L) in a bottle and mix well.
2. Open the front protection cover.





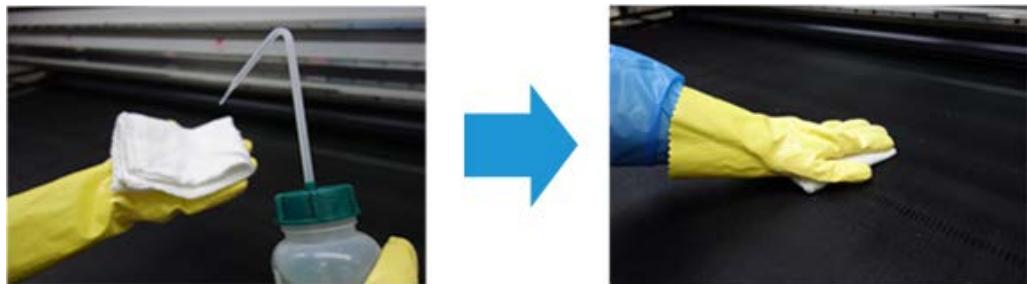

3. Soak a wipe cloth with a proper amount of the cleaning liquid made in step 1 and wipe the belt. Press the feed or back feed button on the front panel to rotate the belt and wipe the belt all the way around. Wring out the wipe cloth and then frequently soak the wipe cloth with the cleaning liquid.



4. Close the front protection cover.

3.9.2 Removing Ink Film

If an ink film has formed on the belt, remove the ink film.

Frequency	When necessary/When a problem occurs	
User Permissions	L	
Required Number of Workers	1 person	
Personal Protective Equipment	The following is the protective equipment that must be worn when using the ethanol recommended by Epson. For details, refer to the instructions of the SDS for the ethanol you are actually using.	
	Eye protection (For organic solvent use; Optimal is a goggle-type that seals against your face)	
		
	Gas mask (For organic solvent use)	
		
	Protective gloves (Butyl or polyurethane)	
		
Protective clothing (Long-sleeved)		
Hat or hair net (Persons with long hair must be tied together with a hair net also worn)		
Safety shoes		

Required Items			
Item	Quantity	Details/Use	
Ink film remover (for pigment ink)	7 L	Recommended product <ul style="list-style-type: none"> • NETACOL-VL (ATR) • BP-WASH-SF (Murayama Chemical Laboratory) • FORCLEAN (ATR) 	A solvent that removes ink films that formed on the belt. Mix with tap water before use.
Container	1	Commercially available	This container is used to hold an ink film remover made by mixing tap water and remover.

1. Put the ink film remover (7 L) and tap water (10 L) in the container and mix well.
2. Operate the lever to close the water supply valve.



3. Check to see that water has filled up to the partition of the tank on the bottom of the cleaning brushes. If there is not enough water accumulated, use a bucket or the like to pour in tap water.

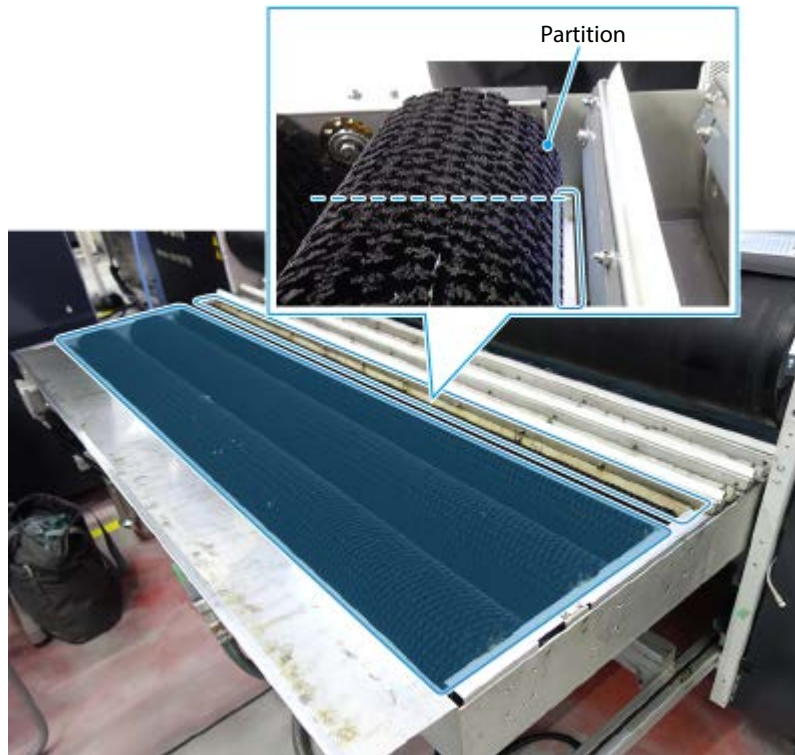

4. Check to see that no water remains in the tank at the bottom of the scraper.

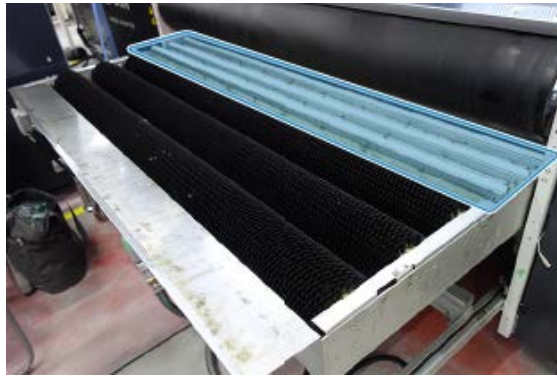

5. Turn the left drain valve in the direction of the arrow to close it.

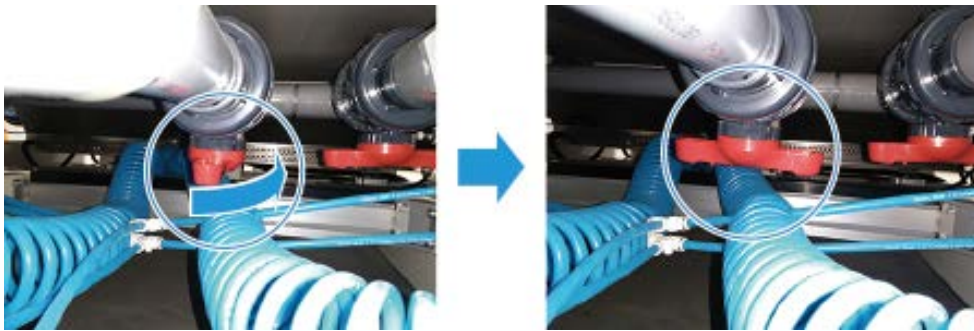

6. Pour the ink film remover made in step 1 into the tank on the bottom of the cleaning brushes.



7. Return the belt cleaning unit to the original position.

8. In Leonardo, open [Maintenance] and then select [Status flags] - [Complete washing].
Confirm the message displayed and click [Yes] to start belt cleaning.
When belt cleaning is completed, the tower lamp changes from white to green. When belt cleaning is completed, perform [Complete washing] again, for a total of eight times.
9. Turn the left drain valve in the direction of the arrow to open it.
The ink film remover in the cleaning tank is drained.

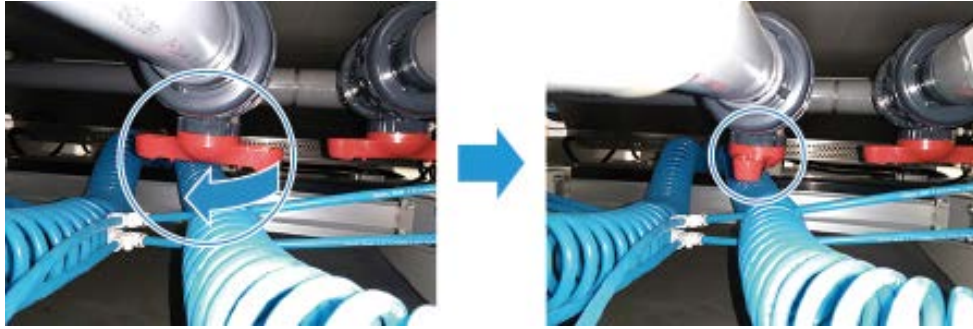

10. Operate the lever to open the water supply valve.



If the fabric attached to the belt floats even after removing the ink film, reapply glue. For more information, refer to "Glue Re-Application".

3.10. Cleaning the Area around the Head and Inspecting the Sub-tank Rack

Frequency	Every week/When a problem occurs, When a large amount of printing is completed
User Permissions	
Personal Protective Equipment	Protective gloves and clothing, eye protection
Required Items	Clean stick, cleaning cloth, maintenance liquid, plastic container, antistatic wrist strap, hex key (width: 4 mm), flashlight



CAUTION

Be sure to wear eye protection.
Failure to do so could cause ink to splash into the eyes.



Do not use normal tap water.
Be sure to use the specified clean stick and cleaning cloth.

1. Press the emergency stop button.
2. Open the front protection cover.



3. Turn the fixing screws on the left side of the flushing plate counterclockwise to loosen them.

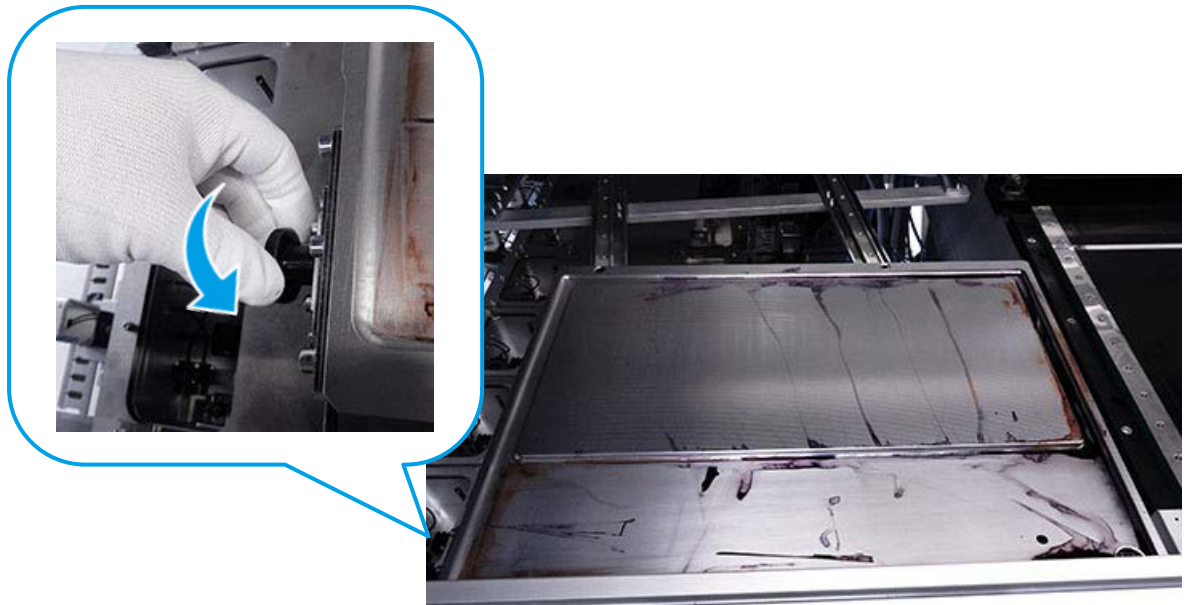

4. Move the flushing plate to the rear.



5. Close the front protection cover.

6. Release the emergency stop button.

7. Execute Set point.

On the Leonardo operation screen, click [Setpoint] and then press the reset button on the main electric panel. The head carriage returns to the origin position and moves to the cleaning station.

8. Move the head carriage to the flushing area.
 On the Leonardo operation screen, open [Maintenance] (1), and click [+] (2) for [Carriage] under [Axes] once.
 When the head carriage moves to the center, click [+] again.
 The head carriage moves to the left into the flushing area.

	<p>Do not work for a long period of time while the head carriage is uncapped. Doing so can cause the print head nozzles to clog, causing a printing error. Pigment ink in particular causes a failure if left uncapped for 24 hours.</p>
---	--

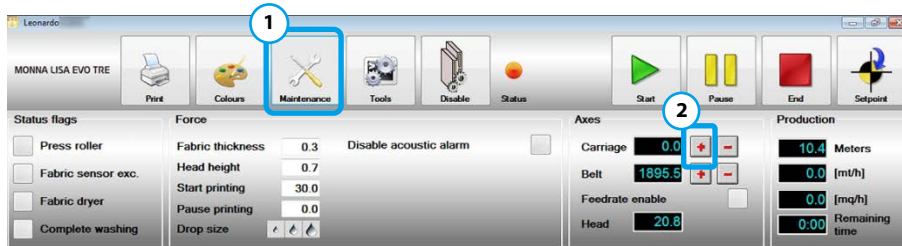

9. Press the emergency stop button.
10. Close the Leonardo screen and shut down the PC.
11. Turn the main power switch to 0 (OFF) to turn the power off.
12. Open the side cover on the side of the sub-tank rack.
 Remove the three screws of the side cover using the hex key (width: 4 mm).
 This photograph shows the 10 L ink tank model.



13. Remove the side cover.

For the 3 L ink cartridge model, proceed to step 16. Steps 14 and 15 are not applicable.

14. Hold the parts on the sub-tank rack as indicated by circles below with both hands, and pull it out from the ink tank housing until stopped by the stoppers.

	<p>Be careful of the following so as not to damage the cables:</p> <ul style="list-style-type: none">• Do not allow the sub-tank rack wheels to run over the cables.• Do not pull the cables hard or apply excessive force.
---	--



15. Visually check for leaks in the ink path of the sub-tank rack.

- Check the connections of the ink tubes: [1], [2]
- Check for ink pack breakage and ink leaks: [3]

After checking, proceed to step 17. For the 10 L ink cartridge model, step 16 is not applicable.

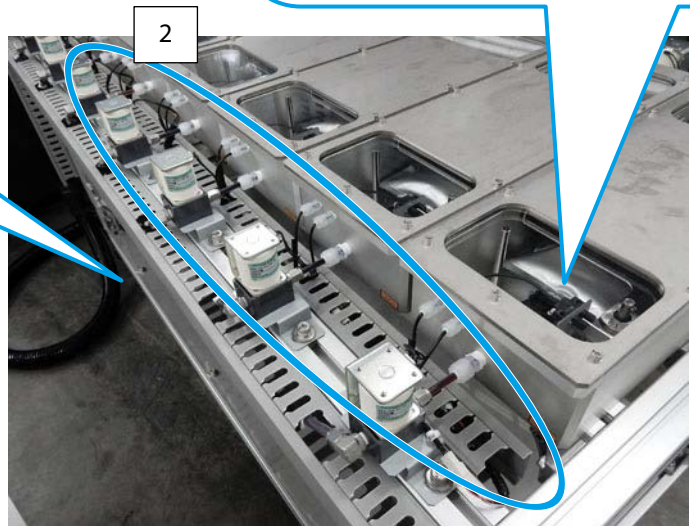
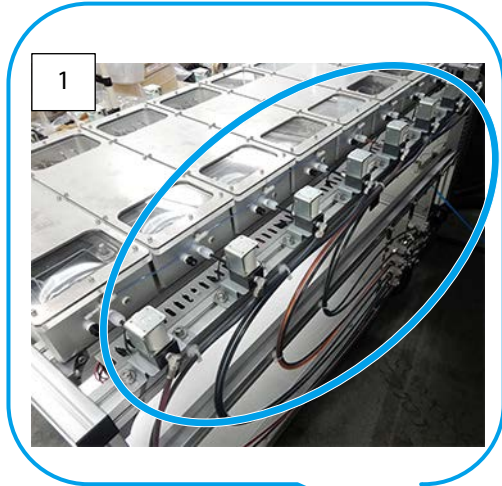

16. For the 3 L ink cartridge model, check the following.

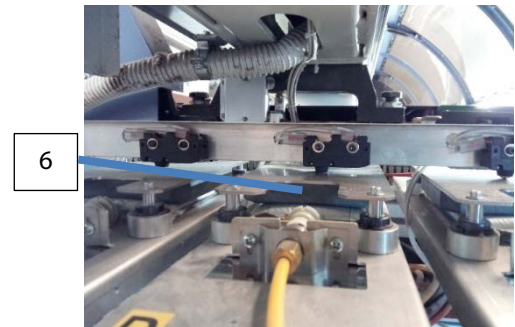
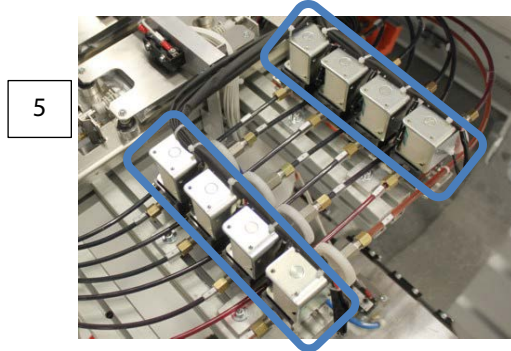
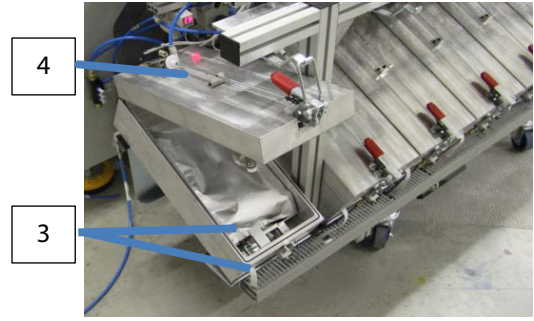
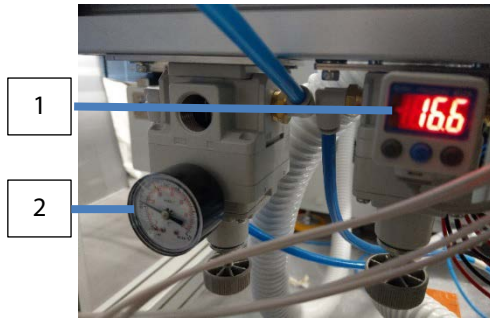

No.	Element	Function
1	Pressure regulator for subtanks	Check the pressure. Value: 150 to 170
2	Pressure regulator	Check the pressure. Value: 0.5 bar
3	Ink tank	Check that there are no ink leaks from the ink tank and joints under the tank. Check all tanks (8 locations).
4	Ink tank handle	Check that there are no ink leaks from the ink tank and joints under the tank. Check all tanks (8 locations).
5	Solenoid valve	Check that there are no ink leaks around the solenoid valves on the input (left: 8 locations) and output (right: 8 locations) sides of the sub-tank rack. With the input and output sides, there are a total of 16 locations to check.
6	Sub-tank micro switch	Check that the switch is OFF when the sub-tank is lowered. Check all tanks (8 locations).
7	Sub-tank rack	Check that there are no ink leaks like the one shown in this image. Check all tanks (8 locations).

17. Open the front left cover.
Remove the two screws from the cover.





18. Remove the cover.





19. Wear eye protection and antistatic wrist strap.

20. Enter the ink tank housing with the following tools:

Cleaning cloth, clean stick, a container of maintenance liquid, flashlight

 CAUTION	
	<p>Manufacturer does not under any circumstances require any access inside of the machine for maintenance. All operations can and must be carried out from the outside.</p> 

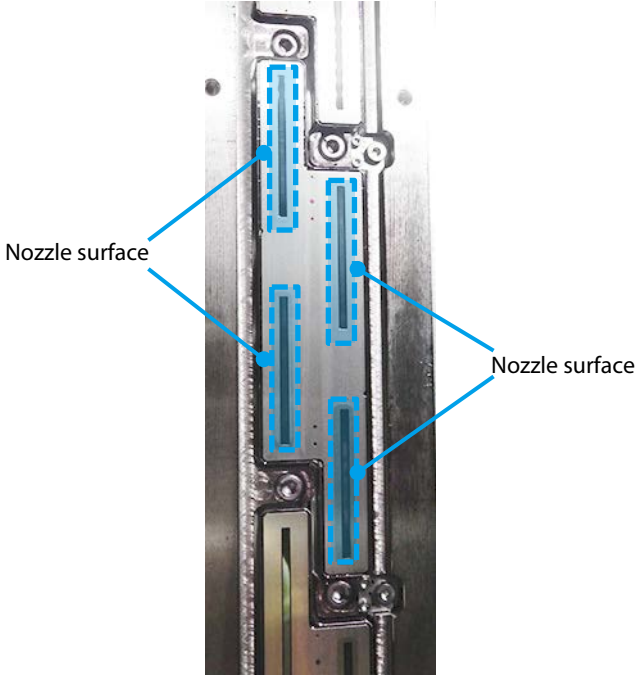
21. While shining the flashlight at your hands, wipe off fluffy dust from the head front and ink stains on the head side face using the clean stick.

 CAUTION 	<p>Observe the following points when cleaning the caps, wipers, and heads. Failure to do so may cause a head fault.</p> <p>If these points are not observed, we will charge for repairs even during the warranty period.</p> <ul style="list-style-type: none">• Do not use normal tap water.• Do not use anything except for the clean stick and cleaning cloth.
	<p>Be careful not to touch the nozzle surface of the head or wipe it with the clean stick.</p> <p>Touching the nozzle surface may cause a printing error.</p> 
	<p>Completely wipe off ink-stained fiber or similar dust. Printing with such dust remaining on the parts may cause ink to drip on the fabric, resulting in a printing error.</p> <p>Use a separate dry stick to remove any residual ink or cleaning liquid.</p>



At a location where the flushing plate rail interferes with replacement operation, move the head carriage manually.



Flushing plate rails



After moving the head carriage to the outside, be sure to return it to the inside. If it is not returned to the inside, the sensor on the head carriage may activate, and you may not be able to execute Set point.

22. When cleaning is finished, exit the ink tank housing.
23. Attach the front left cover.
24. Tighten the two screws of the cover.
25. Return the sub-tank rack to the original position.
26. Attach the side cover of the sub-tank rack side and tighten the three screws using the hex key (width: 4 mm).
27. Turn the main power switch to 1 (ON) to turn the power on.
28. Start up Leonardo.

29. Release the emergency stop button.

30. Execute Set point.

On the Leonardo operation screen, click [Setpoint] and then press the reset button on the main electric panel.

31. Press the emergency stop button.

32. Open the front protection cover of the flushing area.



33. Return the flushing plate to the original position.



The location of the flushing plate is detected by sensor. Printing cannot be performed if it is not returned to the correct location.

34. Turn the fixing screws on the left side of the flushing plate clockwise to tighten them.

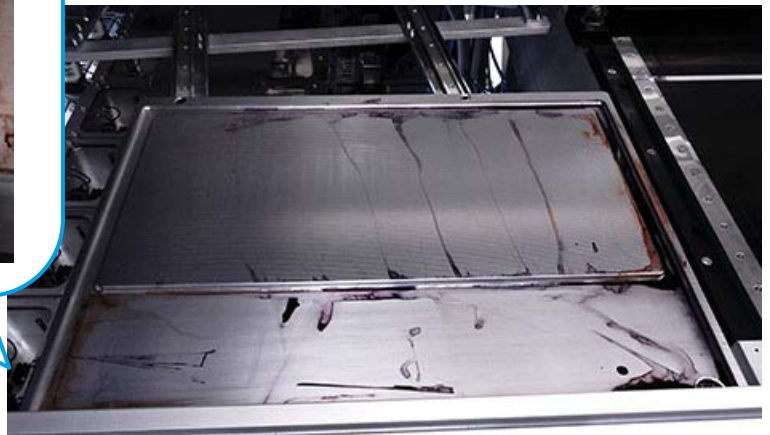

35. Close the front protection cover.

36. Release the emergency stop button.

37. Execute Set point.

On the Leonardo operation screen, click [Setpoint] and then press the reset button on the main electric panel. The head carriage returns to the origin position and moves to the cleaning station.

38. From [Maintenance] menu of Leonardo, execute head cleaning.

Refer to the "Operation Guide" for the corresponding procedures.

39. Perform a nozzle check.

Refer to the "Operation Guide" for the corresponding procedures.

3.11. Cleaning the Cleaning Brushes and the Area around Them

Frequency	Every week/When necessary (After printing on fabric with fuzzy surface)
User Permissions	L
Personal Protective Equipment	Protective gloves and clothing
Required Items	Hex key (width: 3 mm, 6 mm)

Before starting work, turn off the machine.

1. Turn the left drain valve in the direction of the arrow to close it.

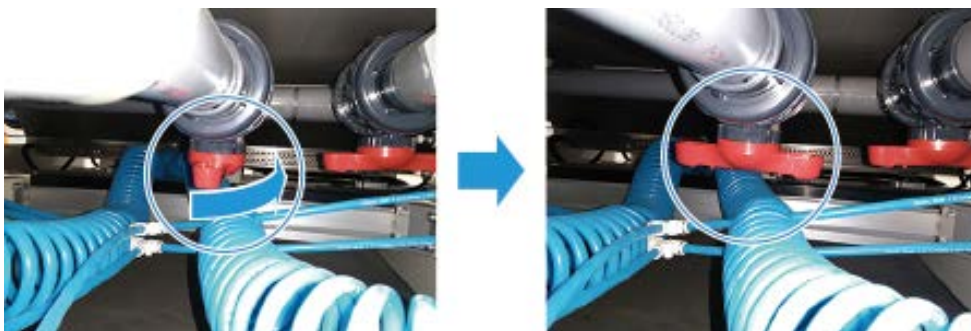

2. Remove the one screw of each fixing block [2] on the left and right using the hex key (width: 6 mm).



Store the removed screws to ensure they are not dropped or placed somewhere they can cause damage.

Right side

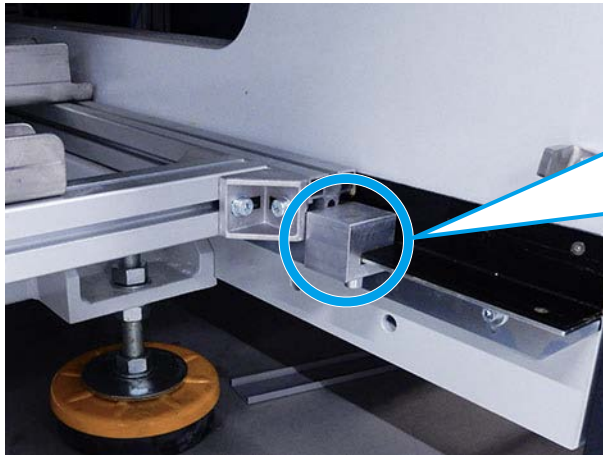

Left side



3. Pull the belt cleaning carriage toward you and pull out the belt cleaning tank.

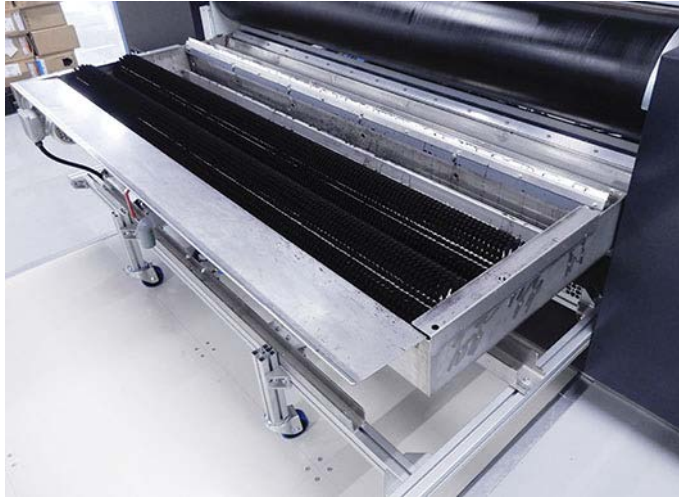

4. Attach the belt cleaning unit wheels on the right and left sides.
5. Remove the stopper and pull out the belt cleaning tank completely.
6. Remove all fiber and other dust from the cleaning brushes.

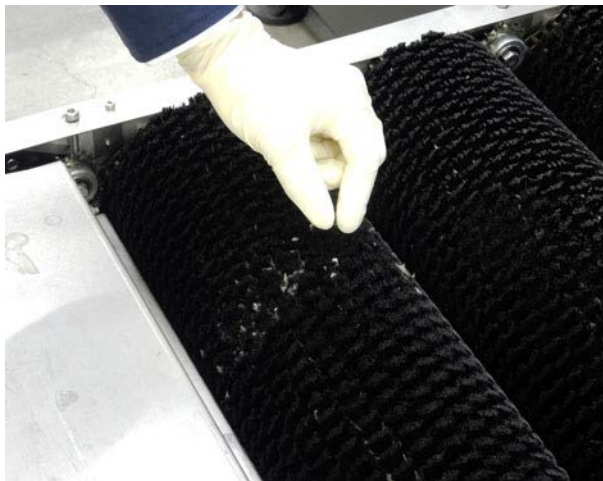

For the cleaning brushes, a metallic brush as shown below can also be used.



7. When cleaning is finished, return the belt cleaning tank to the original position.
Return the belt cleaning carriage to the carriage rail. Attach the stopper and remove the belt cleaning unit wheels.
8. Attach the two fixing blocks to the left and right, and tighten the one screw of each using the hex key (width: 6 mm) to secure them.
9. Attach the two fasteners, and tighten the one screw of each using the hex key (width: 3 mm) to secure them.
10. Turn the left drain valve in the direction of the arrow to open it.

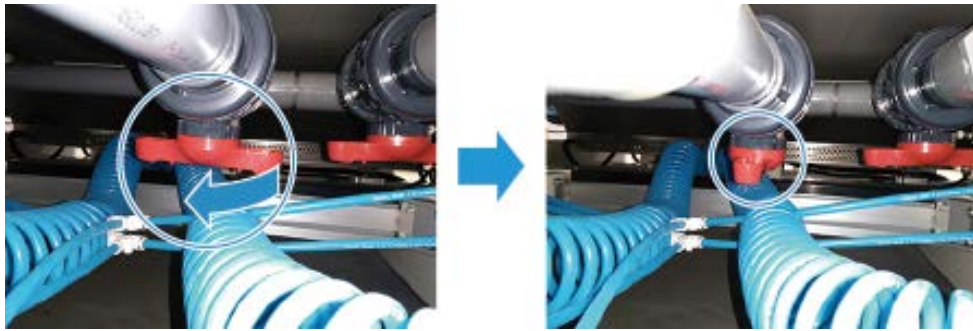

This completes the work.

3.12. Cleaning the Head Cover

Frequency	When necessary
User Permissions	L
Personal Protective Equipment	Protective gloves and clothing
Required Items	Cleaning cloth, maintenance liquid, plastic container

Before starting work, turn off the machine.

1. Open the front protection cover.
2. Moisten the cleaning cloth with maintenance liquid and wipe the head cover surface.



Completely wipe off ink-stained fiber or similar dust. Printing with such dust remaining on the parts may cause ink to drip on the fabric, resulting in a printing error.



3. When cleaning is finished, close the front protection cover.

This completes the cleaning work.

3.13. Cleaning the Plate (Guide Beside the Belt)

Frequency	When necessary
User Permissions	L
Personal Protective Equipment	Protective gloves and clothing
Required Items	Cleaning cloth, maintenance liquid, plastic container



WARNING

Operator must control the guides at the end to be screwed in the proper way and pay attention to the belt edge to be guided and keeping the right belt alignment.

If the plate (guide beside the belt) is stained by ink, wipe it off.

Before starting work, turn off the machine.

1. Open the front protection cover.
2. Wipe off the right and left plates using the cleaning cloth moistened with maintenance liquid.



3. When cleaning is finished, close the front protection cover.

This completes the cleaning work.

3.14. Cleaning the Carriage Operating Parts

Frequency	Every month
User Permissions	L
Personal Protective Equipment	Protective gloves and clothing
Required Items	Cleaning cloth

1. Move the head carriage to the flushing area.
On the Leonardo operation screen, open [Maintenance] (1), and click [+] (2) for [Carriage] under [Axes] once. When the head carriage moves to the center, click [+] again. The head carriage moves to the left into the flushing area.

	<p>Do not work for a long period of time while the head carriage is uncapped. Doing so can cause the print head nozzles to clog, causing a printing error. Pigment ink in particular causes a failure if left uncapped for 24 hours.</p>
---	--



2. Press the emergency stop button.
3. Close the Leonardo screen and shut down the PC.
4. Turn the main power switch to 0 (OFF) to turn the power off.
5. Open the front protection cover.

6. Clean the carriage rail with the cleaning cloth.

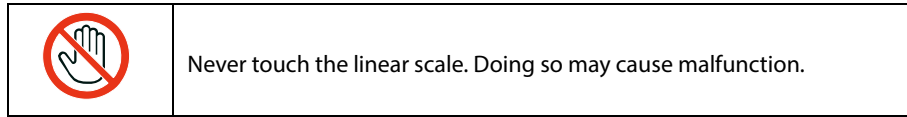

Wipe both right and left sides.

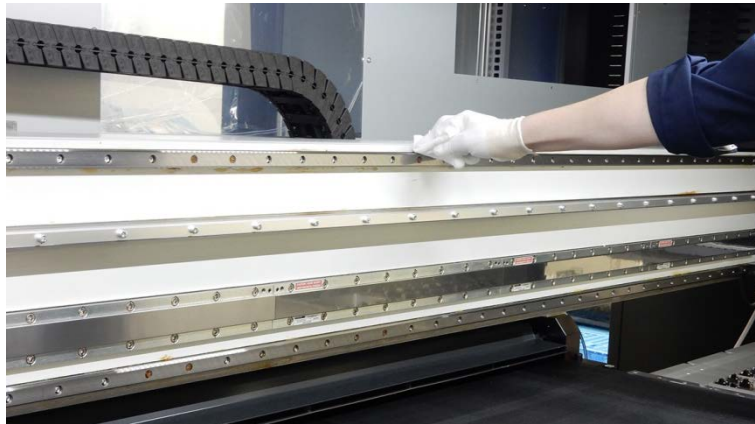

7. When cleaning is finished, close the front protection cover.
8. Turn the main power switch to 1 (ON) to turn the power on.
9. Start up Leonardo.

10. Release the emergency stop button.

11. Execute Set point.

On the Leonardo operation screen, click [Setpoint] and then press the reset button on the main electric panel.

3.15. Applying Grease to the Carriage Operating Parts

Frequency	Every six months
User Permissions	
Personal Protective Equipment	Protective gloves and clothing
Required Items	Cleaning cloth, carriage grease, grease pump

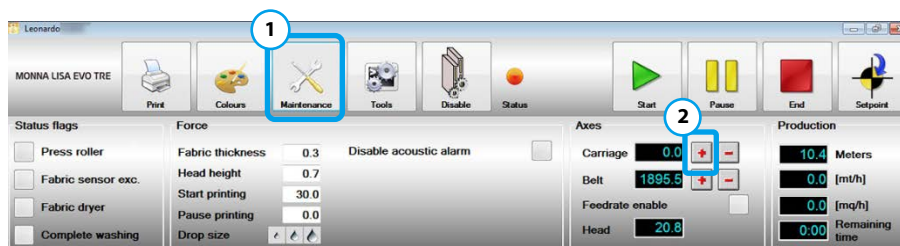

1. Move the head carriage to the flushing area.
 On the Leonardo operation screen, open [Maintenance] (1), and click [+] (2) for [Carriage] under [Axes] once.
 When the head carriage moves to the center, click [+] again.
 The head carriage moves to the left into the flushing area.

	<p>Do not work for a long period of time while the head carriage is uncapped. Doing so can cause the print head nozzles to clog, causing a printing error. Pigment ink in particular causes a failure if left uncapped for 24 hours.</p>
---	--



2. Press the emergency stop button.
3. Close the Leonardo screen and shut down the PC.
4. Turn the main power switch to 0 (OFF) to turn the power off.
5. Open the front protection cover.
6. Clean the carriage rail with the cleaning cloth. (See: 3.13 Cleaning the Carriage Operating Parts)

7. Apply a proper amount of carriage grease with the grease pump to the top and bottom surfaces of the carriage rail cleaned in Procedure 6.

	Do not add too much grease. Doing so can result in excess grease dripping onto fabric, resulting in a printing error.
	The proper grease amount is 1 to 3 g for each oil filler hole. Stop adding grease if it starts to come out from the edges of the slide.
	Do not touch the carriage operating parts. Doing so may cause malfunction.

Top surface

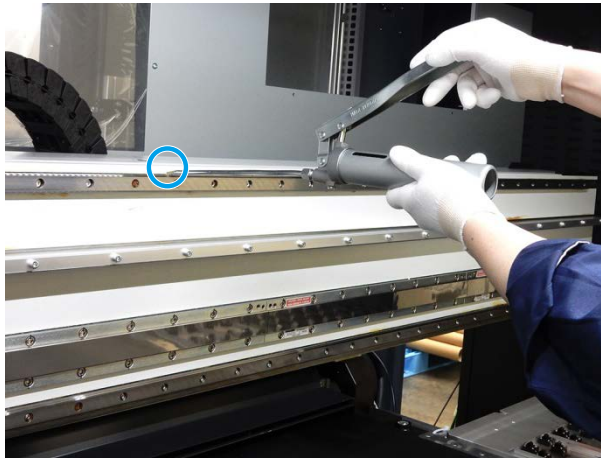

Bottom surface



8. When work is finished, close the front protection cover.
9. Turn the main power switch to 1 (ON) to turn the power on.

10. Start up Leonardo.

11. Release the emergency stop button.

12. Execute Set point.

On the Leonardo operation screen, click [Setpoint] and then press the reset button on the main electric panel.

13. On the Leonardo operation screen, specify the length under [Print] and select the [Colours exclusion] check box under [Colours]. Then move the head carriage back and forth five times to spread the grease across the entire surface.

This completes the work.

Continue on to perform "3.15 Applying Grease to the Scan Spindle".

3.16. Applying Grease to the Scan Spindle

Frequency	Every six months
User Permissions	
Personal Protective Equipment	Protective gloves and clothing
Required Items	Scan spindle grease, grease pump

After applying grease to the carriage operating parts (See: 3.14 Applying Grease to the Carriage Operating Parts), apply grease to the scan spindle.

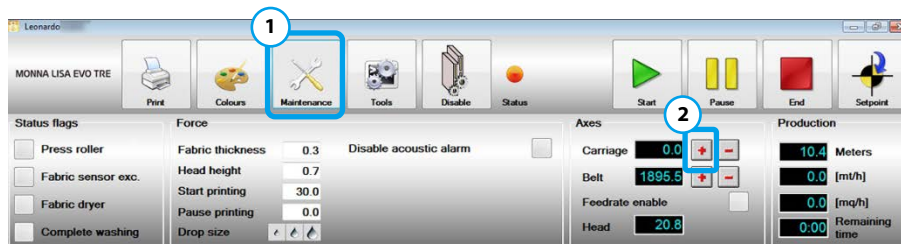

1. Move the head carriage to the center of the print head operating area.
On the Leonardo operation screen, open [Maintenance] (1), and click [+] (2) for [Carriage] under [Axes] once. The head carriage moves to the left and then to the center.

	Do not work for a long period of time while the head carriage is uncapped. Doing so can cause the print head nozzles to clog, causing a printing error. Pigment ink in particular causes a failure if left uncapped for 24 hours.
--	---



2. Press the emergency stop button.
3. Close the Leonardo screen and shut down the PC.
4. Turn the main power switch to 0 (OFF) to turn the power off.
5. Open the front protection cover.

6. Using the grease pump, add grease through the oil filler hole on the linear block on both sides of the scan spindle.

	Do not add too much grease. Doing so can result in excess grease dripping onto fabric, resulting in a printing error.
	The proper grease amount is 1 to 3 g for each oil filler hole. Stop adding grease if it starts to come out from the edges of the slide.

Right side

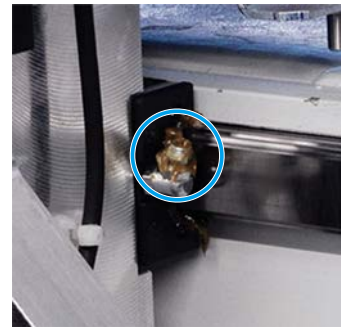
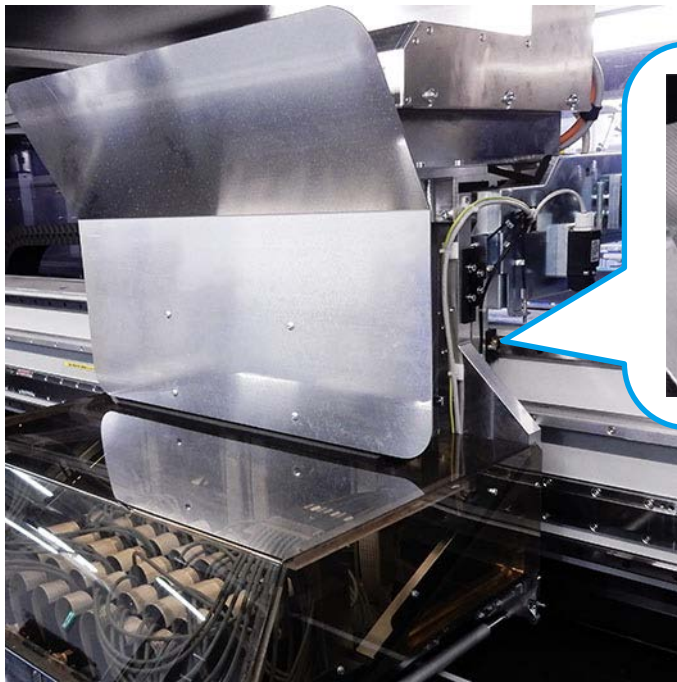

Left side

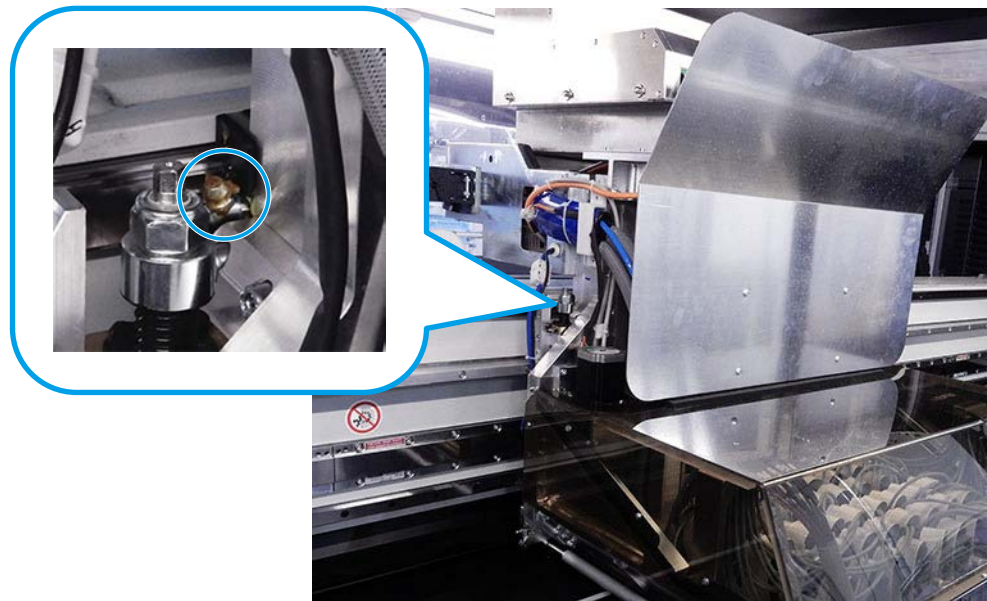

7. When work is finished, close the front protection cover.
8. Turn the main power switch to 1 (ON) to turn the power on.
9. Start up Leonardo.
10. Release the emergency stop button.
11. Execute Set point.
On the Leonardo operation screen, click [Setpoint] and then press the reset button on the main electric panel. The head carriage moves to the cleaning station.

3.17. Checking for Water Leaks in the Pipe Joints

Frequency	Every month
User Permissions	L
Personal Protective Equipment	Protective gloves and clothing

Check that the joints for the cleaning tank of the cleaning unit [1] and [2] are not loosened and are free water leaks.

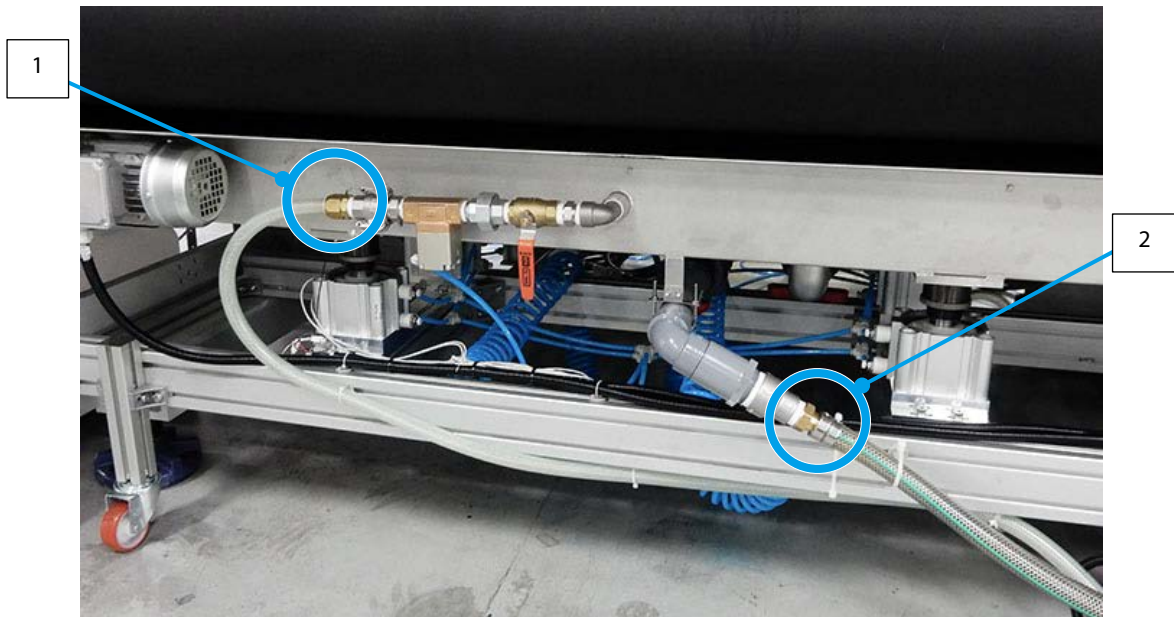

3.18. Discharging the Compressed Air Route Regulator and Dry Air System Lubricator

Dispose of any water or oil that has accumulated in the compressed air route regulator and dry air system lubricator. For the compressed air route regulator, some models require that water and impurities be discharged manually, while other models discharge water and impurities automatically.

3.18.1 Discharging the Compressed Air Route Regulator

Frequency	Everyday
User Permissions	H
Required Items	Plastic container and personal protective equipment (protective gloves and clothing)

For models where the water and impurities are discharged manually

1. Close the facility's pressurized air valve.
2. Check that the machine is in the Power Off Status.
3. Set the plastic container under the air filter drain and press the two orange buttons. Check to see that the accumulated water was discharged.



4. Open the facility's pressurized air valve.

If water and impurities are not discharged

1. Open the facility's pressurized air valve.
2. Set the plastic container under the air filter drain.
3. Press the two buttons on the air filter. The water and impurities that have accumulated in the air filter will be discharged with force.

For models where the water and impurities are discharged automatically

The water and impurities are discharged automatically. Dispose of the water and impurities collected in the container.



3.18.2 Discharging the Dry Air System Lubricator (in Flushing Area)

The oil is discharged automatically. Dispose of the oil collected in the container.



3.18.3 Dry Air System (DAS)

Open the rear protective cover, and if there is a Dry Air System (DAS) on the right side, perform the DAS inspection.

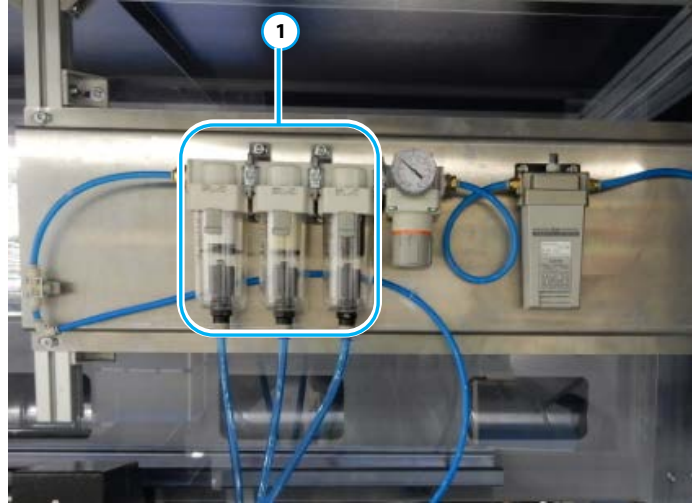

No.	Element	Function
1	Air filter	Check that water has not accumulated and that the air filter is not dirty.

How to replace the air filter:

If water has accumulated in the air filter or the air filter is dirty, take the following corrective measures.

1. While pressing down on the lever for the filter cover (1), turn it towards the left (2).



2. Clean inside the cover and wipe away any water. Replace the air filter.
3. When the inspection is complete, attach the air filter cover in the reverse position, based on step 1.

3.19. Cleaning/Replacing the Mist Filter

Frequency	Cleaning: Every month Replacement: When necessary
User Permissions	L
Personal Protective Equipment	Protective gloves and clothing
Required Items	Hex key (width: 3 mm) Replacement: Replacement mist filter

1. Remove the maintenance window cover from the mist filter on the side face of the machine.
Remove the four screws using the hex key (width: 3 mm) and remove the cover.



2. Remove the two screws from the mist filter cover and remove the cover.



3. Pull out the mist filter.

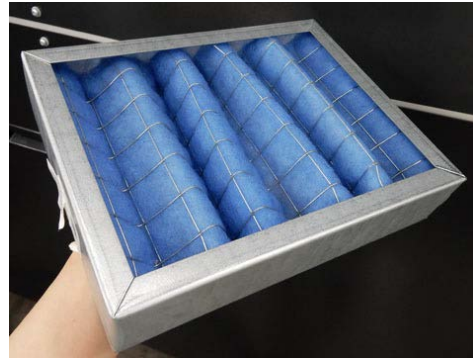

Take the removed mist filter and wash it with water, remove any dirt, dry it, and then store it for the next replacement.

4. Re-install a clean filter.



Make sure that the mist filter is set in the correct direction while attaching it.

Top side: Blue, Bottom side: White

If you washed the filter, absolutely do not insert it until it dries. This machine is equipped with a replacement filter.

Please swap all the times cleaned filter with the second spare in order to avoid wet condition on it and guaranteeing the right productivity and printing efficiency.

5. Attach the mist filter cover and tighten the two screws to secure it.
6. Attach the maintenance window cover and tighten the four screws of the cover using the hex key (width: 3 mm) to secure it.

3.20. Checking the Blower and Cleaning/Replacing the Filter

Frequency	Inspection: Every month Cleaning/Replacement: When necessary
User Permissions	L
Personal Protective Equipment	Protective gloves and clothing

Clean the filter for the blower on the rear side of the machine.

1. Remove the screw from the filter cover.



2. Lift the cover to remove it.



3. Remove the filter and clean dirt and dust with a vacuum cleaner.



4. After cleaning, attach the filter again.
Replace the filter if it is extremely dirty.

3.21. Cleaning/Replacing the Cooling Fan Filters

If the cooling fan filters are used continuously without cleaning, the machine will become unable to lower the temperature of the print head drive substrate, which may result in a failure. Follow the procedures below to clean the cooling fan filters. If a stain cannot be removed even after cleaning, that cooling fan filter must be replaced. (See: 3.20.2 Replacing the Cooling Fan Filters)

To purchase new cooling fan filters, inquire with qualified service personnel.

Frequency	Every month When an error message is displayed stating that the temperature of the print head drive substrate cannot be lowered
User Permissions	L

3.21.1 Cleaning the Cooling Fan Filters

Required Items	Plastic container, tray, and personal protective equipment (protective gloves and clothing, eye protection)
----------------	---

1. Check that the machine is in the Power Off Status.
2. Open the front protection cover.



3. While holding the cooling fan cover so that it does not fall, loosen the four screws on the cover using the hex key (width: 3 mm) and remove the cover.



4. Remove all eight cooling fan filters.

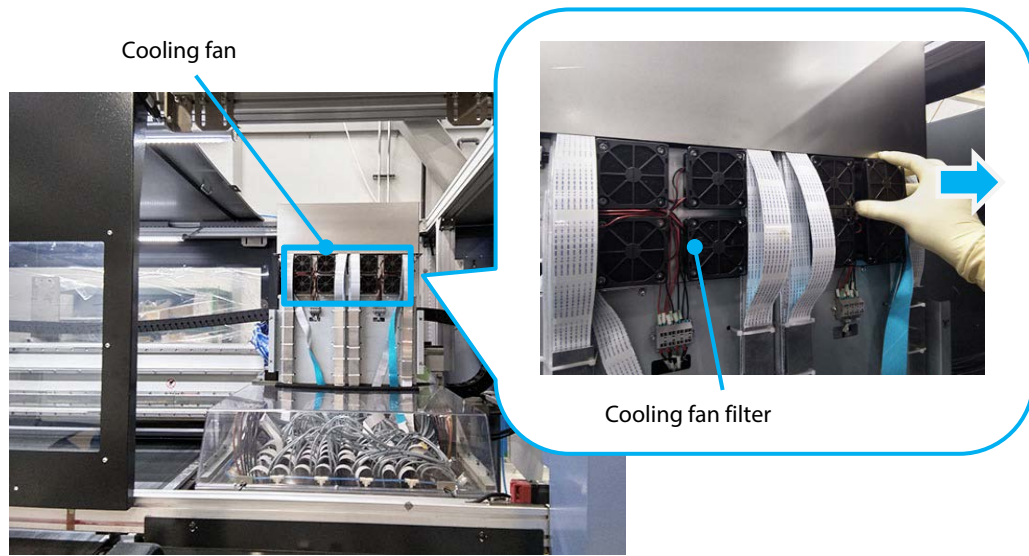

5. Remove the cooling fan filter from the cover.

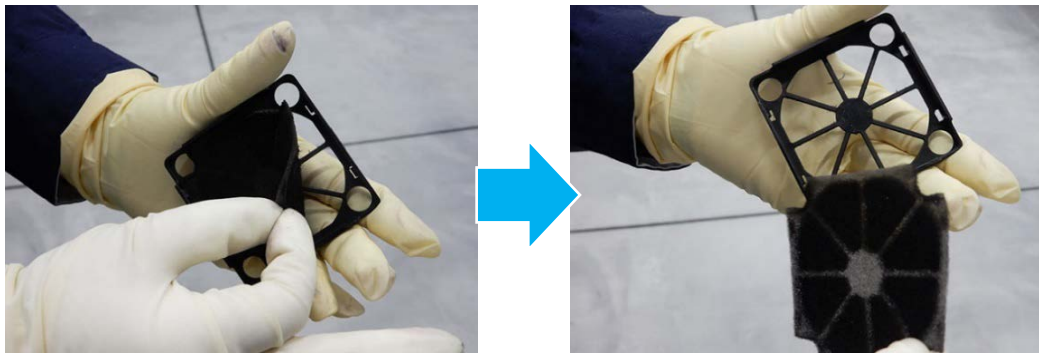

6. Put tap water into the container.

	Wash the cooling filter on the tray, so as not to spill dirty water.
--	--

7. Place the cooling fan filter in the plastic container and wash off the stains by hand.



The dirty water is industrial waste. Dispose of it in the proper manner.

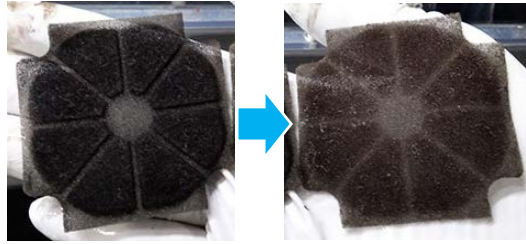

8. Dry the cooling fan filter.

9. Place the cooling fan filter on the cover.

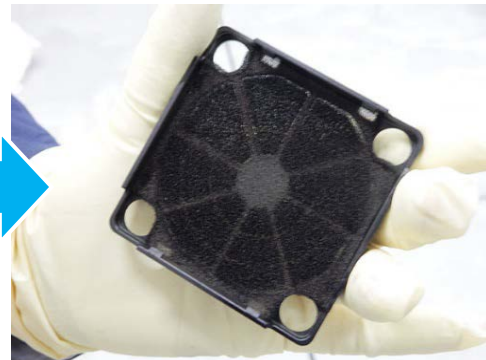
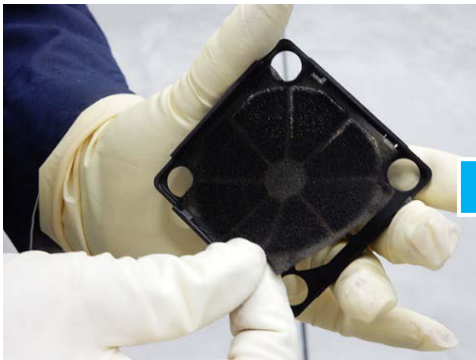

10. Install all the cooling fan filters in their original positions.

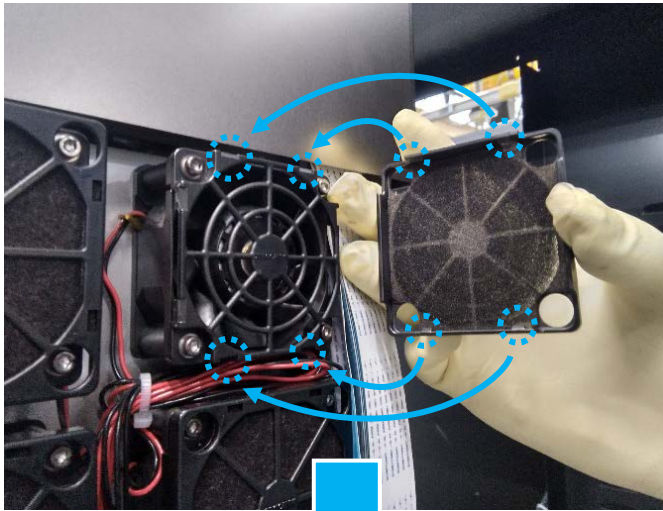

11. Attach the cooling fan cover and tighten the four screws using the hex key (width: 3 mm).

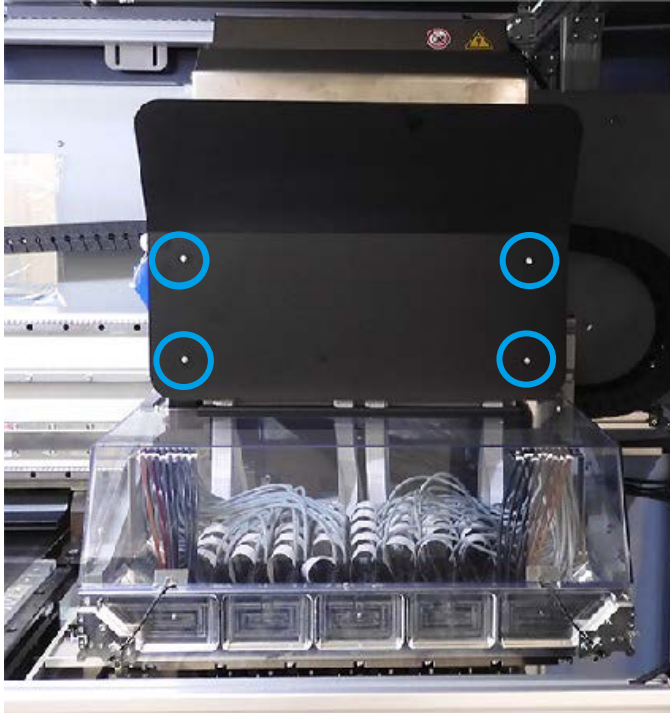

12. Close the front protection cover.

3.21.2 Replacing the Cooling Fan Filters

Required Items	New cooling fan filters and personal protective equipment (protective gloves and clothing, eye protection)
----------------	--

1. Check that the machine is in the Power Off Status.
2. Open the front protection cover.



3. While holding the cooling fan cover so that it does not fall, loosen the four screws on the cover using the hex key (width: 3 mm) and remove the cover.



4. Remove the cooling fan filters.

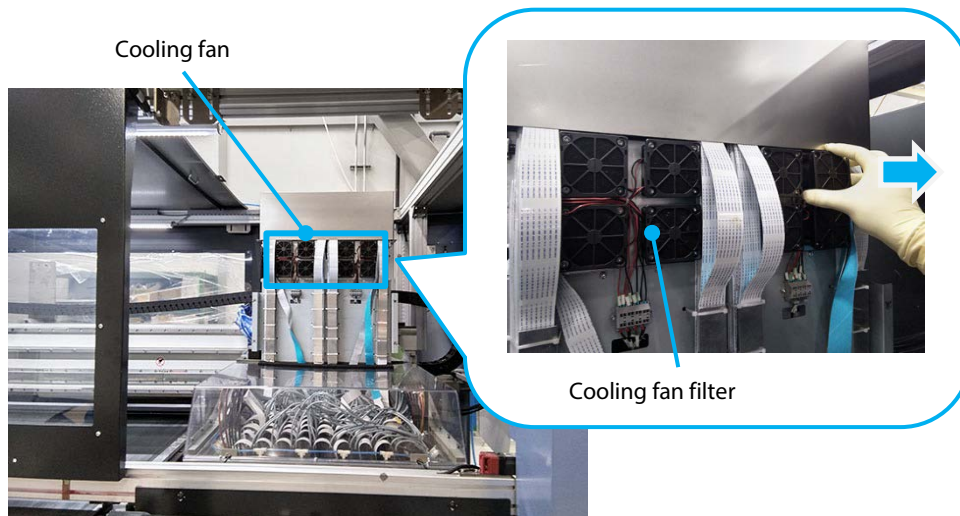

- Remove the cooling fan filter from the cover.

	A dirty filter is industrial waste. Dispose of it in the proper manner.
---	---



- Place the new cooling fan filter on the cover.

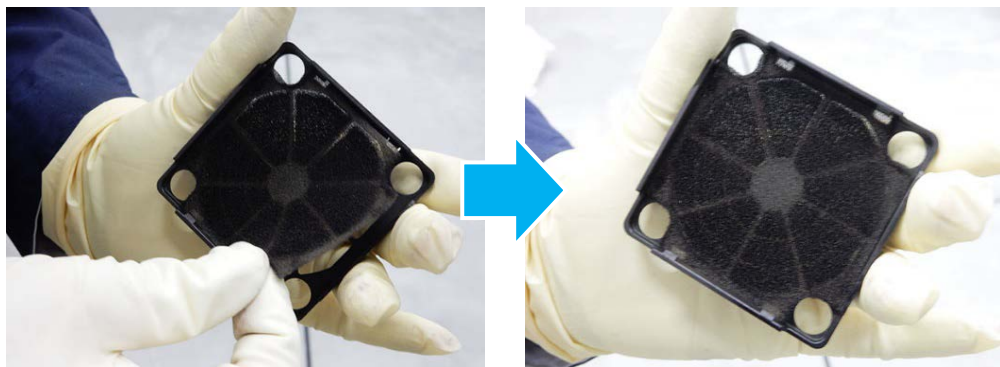

7. Install the cooling fan filters straight in their original positions, with the cover protrusions on the top and bottom sides.

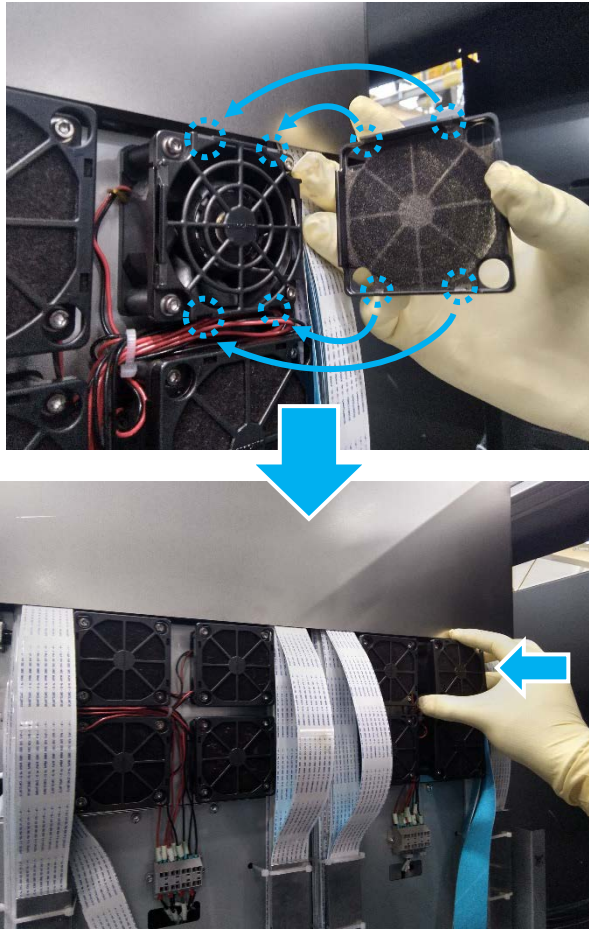

8. Attach the cooling fan cover and tighten the four screws using the hex key (width: 3 mm).

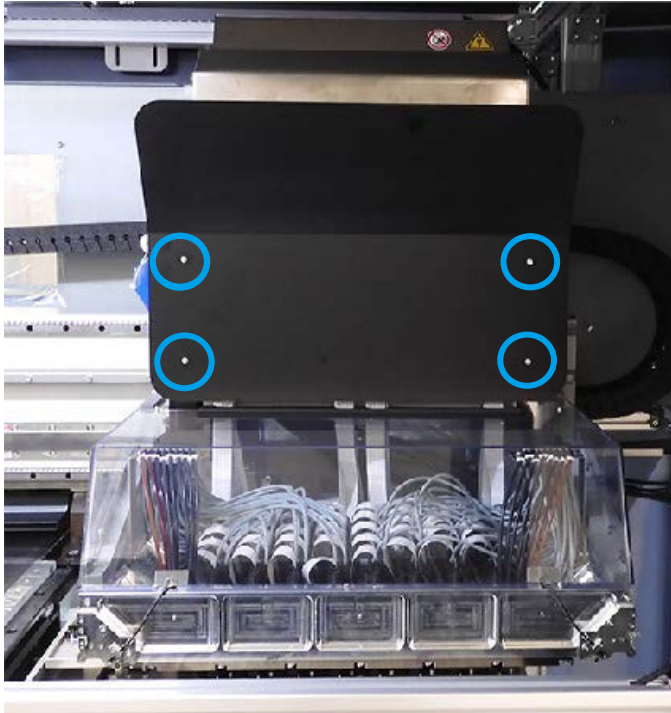

9. Close the front protection cover.

3.22. Checking the Cable Protection Condition

Frequency	Every month
User Permissions	L
Personal Protective Equipment	Protective gloves and clothing

Check the cable protective tubes between the machine and the main electric box for any damage.



4. Adjustment Procedure

4.1. Bi-directional Adjustment

Frequency	When replacing heads/When changing jobs
User Permissions	
Personal Protective Equipment	Protective gloves and clothing

Before performing bi-directional adjustment, implement the following.

- First perform printing and check if the bi-directional is correct or not.
- If bi-directional adjustment is required, refer to the Operation Guide and properly set the fabric thickness.
- If printing cannot be performed properly even after the fabric thickness is adjusted, set the correct bi-directional value in this section.



If you perform settings here, the factory default settings will be overwritten.

Adjust the ink dot position in the head reciprocating path. Make adjustment when vertical misalignment occurs.

1. From the printed result of a printing job, measure the misaligned amount in mm.
2. On the Leonardo operation screen, open [Maintenance] [1] and enter an adjustment value in [Bidirectional] [2]. Then press the Enter key on the keyboard.

An adjustment value of up to 0.500 can be entered. Entering "0.500" moves the ink dot position by 1 mm.

+ side: Moves the returning path toward the cleaning station side.

- side: Moves the returning path toward the flushing area side.

To enter a value larger than 0.500, save the value first by pressing [3], which resets the counter to "0". Then enter an additional value.

Example: To move the position by 1.5 mm

Enter "0.500" (1 mm) and press the Enter key on the keyboard. Press [3] to reset the counter to "0". Then enter an additional "0.250" (0.5 mm) and press the Enter key on the keyboard.

3. Press [3] to save the settings.



If you perform settings here, the factory default settings will be lost.

4. Print again and check the result.

4.2. Belt Feed Amount Adjustment

Frequency	When irregular streaking occurs/When changing jobs
User Permissions	
Personal Protective Equipment	Protective gloves and clothing

When print results have streaks (horizontal banding or uneven colors), adjust the belt feed amount at every printing pass.

1. From the printed result of a printing job, measure the misaligned amount in mm.
2. On the Leonardo operation screen, open [Maintenance] [1] and enter an adjustment value in [Belt] [2]. Then press the Enter key on the keyboard.

An adjustment value of up to 0.500 can be entered. Entering "0.500" changes the belt feed amount by 200 μm .

+ side: Increases the belt feed amount.

- side: Decreases the belt feed amount.

To enter a value larger than 0.500, save the value first by pressing [3], which resets the counter to "0". Then enter an additional value.

Example: To change the amount by 300 μm

Enter "0.500" (200 μm) and press enter on the keyboard. Press [3] to reset the counter to "0". Then enter an additional "0.250" (100 μm) and press enter on the keyboard.



MonnaLisa Evo-Tre. Connected
MonnaLisa Evo-Tre. Machine in emergency

3. Press [3] to save the settings.



Before saving, check once again that the settings are correct. Once you save, the factory default settings will be lost.

4. Print again and check the result.

5. Replacement Procedure

5.1. Cap Replacement

Frequency	When necessary/When a problem occurs (For example, when nozzle clogging is not resolved by cleaning)
User Permissions	L
Personal Protective Equipment	Eye protection, protective gloves and clothing
Required Items	Replacement cap unit, forceps, hex key (width: 2.5 mm), maintenance liquid, clean stick, plastic container



CAUTION

Be sure to wear eye protection.
Failure to do so could cause ink to splash into the eyes.

1. Execute Set point.

On the Leonardo operation screen, click [Setpoint] and then press the reset button on the main electric panel. The head carriage returns to the origin position and moves to the cleaning station.

2. Move the head carriage to the flushing area.

On the Leonardo operation screen, open [Maintenance] (1), and click [+] (2) for [Carriage] under [Axes] once. When the head carriage moves to the center, click [+] again.

The head carriage moves to the left into the flushing area.



Do not work for a long period of time while the head carriage is uncapped.
Doing so can cause the print head nozzles to clog, causing a printing error.
Pigment ink in particular causes a failure if left uncapped for 24 hours.

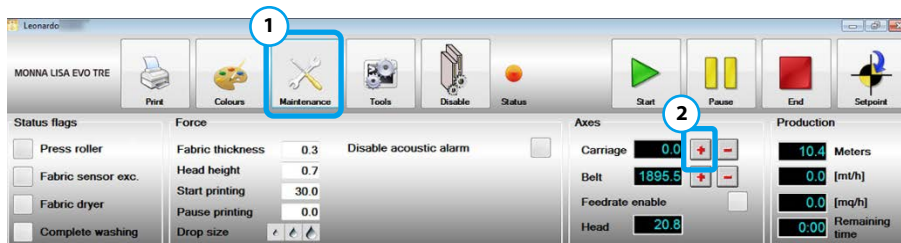

3. Press the emergency stop button.
4. Close the Leonardo screen and shut down the PC.
5. Turn the main power switch to 0 (OFF) to turn the power off.
6. Open the front protection cover.



7. A cap unit is equipped with four caps.
Loosen the screw at the center of the cap unit with the hex key (width: 2.5 mm).



8. While taking care not to let the springs fall out, lift the cap upward keeping it horizontal.

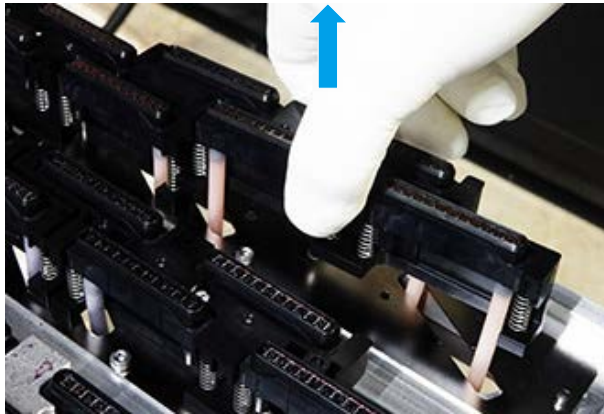

9. Hold the ink tubes with the forceps.

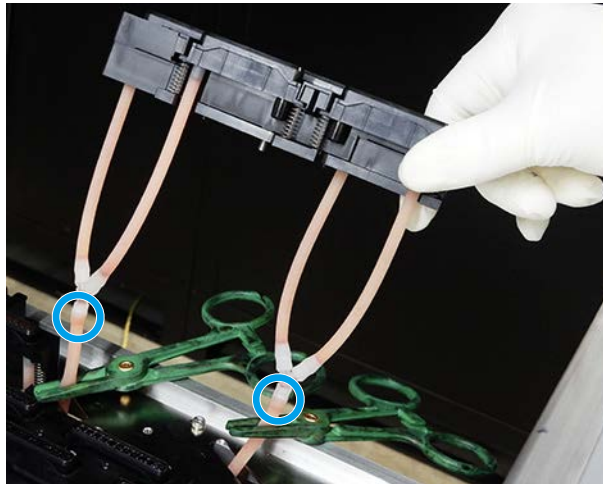

10. Pull out the ink tubes at the locations indicated by circles.
Be careful of splashing ink.

11. Insert tubes into a new cap.
Insert the tubes securely as far as possible.



Do not touch the lip surface of the cap.

12. Remove the forceps from the ink tubes.
13. Attach the cap.
Make sure that all springs are installed.
Make sure that the cap is set horizontally.

- Using fingers covered in a rubber glove, push in the lip section of the cap and check if it returns to its original location.



- Secure the cap unit by tightening the screw at the center with the hex key (width: 2.5 mm).
- Grease may have oozed out of the surface of the lip section.
Wipe the lip section gently using the clean stick moistened with maintenance liquid.



Wipe off any maintenance liquid from the cap surface.

- After replacement, make sure that no tools or other items are left on the print head operating area or carriage operating area.
- Close the front protection cover.
- Turn the main power switch to 1 (ON) to turn the power on.
- Start up Leonardo.
- Release the emergency stop button.
- Execute Set point.
On the Leonardo operation screen, click [Setpoint] and then press the reset button on the main electric panel. The head carriage moves to the cleaning station.

5.2. Wiper Replacement

Frequency	When necessary/When a problem occurs (For example, when nozzle clogging is not resolved by cleaning)
User Permissions	L
Personal Protective Equipment	Eye protection, protective gloves and clothing
Required Items	Replacement wiper unit, hex key (width: 2.5 mm), maintenance liquid, clean stick, cleaning wiper, plastic container



CAUTION

Be sure to wear eye protection.

Failure to do so could cause ink to splash into the eyes.

1. Execute Set point.

On the Leonardo operation screen, click [Setpoint] and then press the reset button on the main electric panel. The head carriage returns to the origin position and moves to the cleaning station.

2. Move the head carriage to the flushing area.

On the Leonardo operation screen, open [Maintenance] (1), and click [+] (2) for [Carriage] under [Axes] once. When the head carriage moves to the center, click [+] again.

The head carriage moves to the left into the flushing area.



Do not work for a long period of time while the head carriage is uncapped.

Doing so can cause the print head nozzles to clog, causing a printing error.

Pigment ink in particular causes a failure if left uncapped for 24 hours.

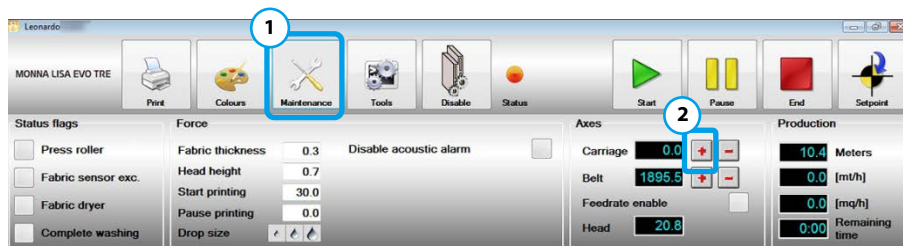

3. Press the emergency stop button.

4. Close the Leonardo screen and shut down the PC.

5. Turn the main power switch to 0 (OFF) to turn the power off.

6. Open the front protection cover.



7. Remove the wiper unit (assembly).

Loosen the screw that secures the wiper unit at the center with the hex key (width: 2.5 mm) and remove the wiper unit.

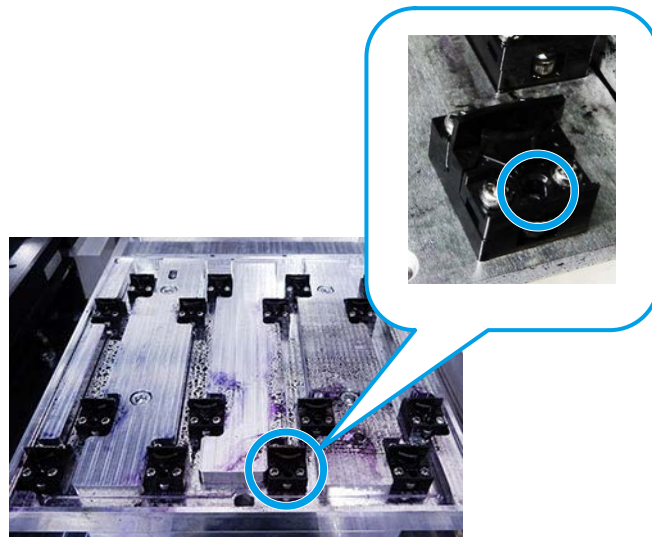

8. Wipe the location where the wiper unit is removed using the cleaning cloth or clean stick moistened with maintenance liquid and dry it.

9. Attach a new wiper unit.

Insert the pin at the installation position into the hole on the bottom surface of the wiper unit.

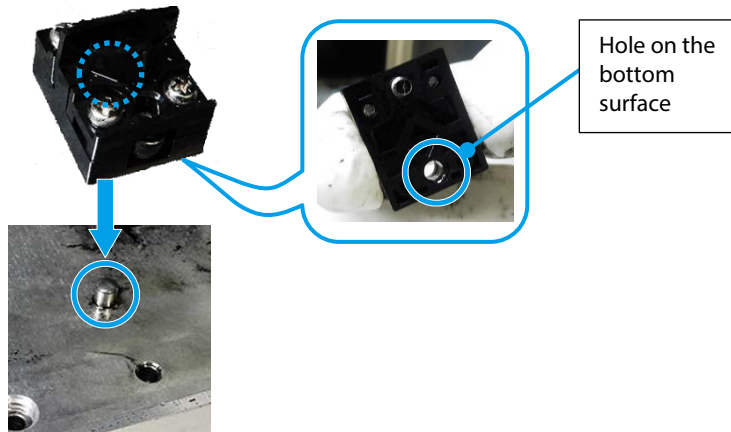

10. Tighten the screw on the wiper unit with the hex key (width: 2.5 mm).



Do not pull the rubber part of the wipers.
When attaching the wiper unit, make sure that the unit is installed in the proper position and direction.



11. Grease may have oozed out of the rubber surface.

Wipe the wiper rubber section gently using the clean stick moistened with maintenance liquid.



After wiping off the maintenance liquid, let the area dry.

12. After replacement, make sure that no tools or other items are left on the print head operating area or carriage operating area.

13. Close the front protection cover.

14. Turn the main power switch to 1 (ON) to turn the power on.

15. Start up Leonardo.

16. Release the emergency stop button.

17. Execute Set point.
On the Leonardo operation screen, click [Setpoint] and then press the reset button on the main electric panel. The head carriage moves to the cleaning station.

5.3. Towel Roller Fabric Replacement

Frequency	When necessary/When a problem occurs
When to Replace	Replace the fabric attached to the towel roller when it is very wet or dirty. If you continue to use it without replacing it, the water left on the belt will not be sufficiently wiped up, leaving water remaining on the belt.
User Permissions	L
Personal Protective Equipment	Protective clothing, protective gloves (for when you touch the ink-stained fabric)
Required Items	Replacement fabric: Non-fluffy fabric with good water-absorption properties (Cotton recommended. Size: 1,850 x 1,600 mm), double-sided tape (Thick), alcohol disinfectant, wipe cloth

1. Check that the machine is in the Power Off Status.
2. Check that the towel roller is on top of the support screws.
3. Remove the towel roller from the machine.
Firmly hold the towel roller in both hands, lift it up slowly and horizontally following the left and right grooves, and remove it from this machine.



Be careful not to interfere with the fabric feeding position sensor, which is located directly below the towel roller. When removing the towel roller, you can avoid interference by tilting the sensor diagonally.

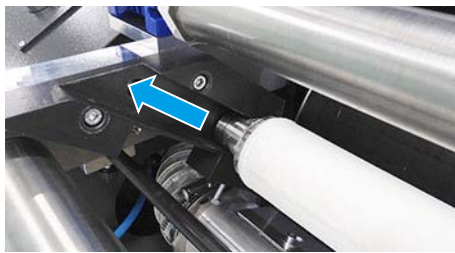

Fabric feeding position sensor

4. Place the towel roller on a horizontal location.

5. Peel off the double-sided tape from the edge of the fabric, and remove the fabric.



6. Use a wipe cloth soaked in alcohol disinfectant to remove any tape adhesive left on the towel roller shaft.

7. Spread out the replacement fabric on a level location free from foreign material.

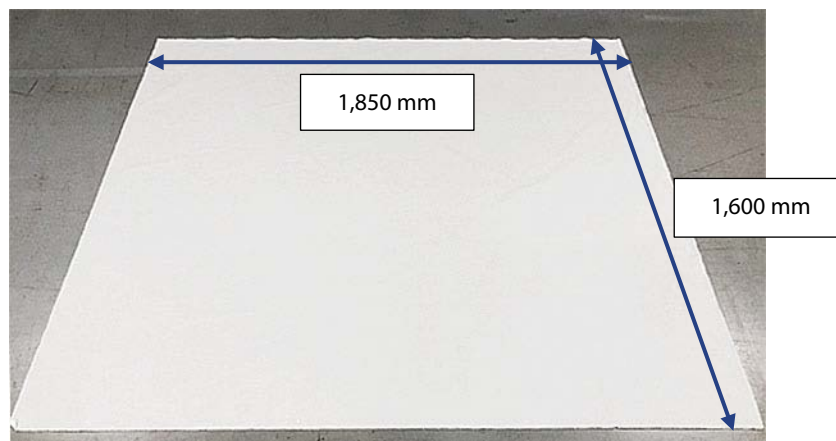

8. Place the towel roller on the edge of the fabric, and affix the opposite side using curing tape.



9. Apply double-sided tape to the towel roller shaft.

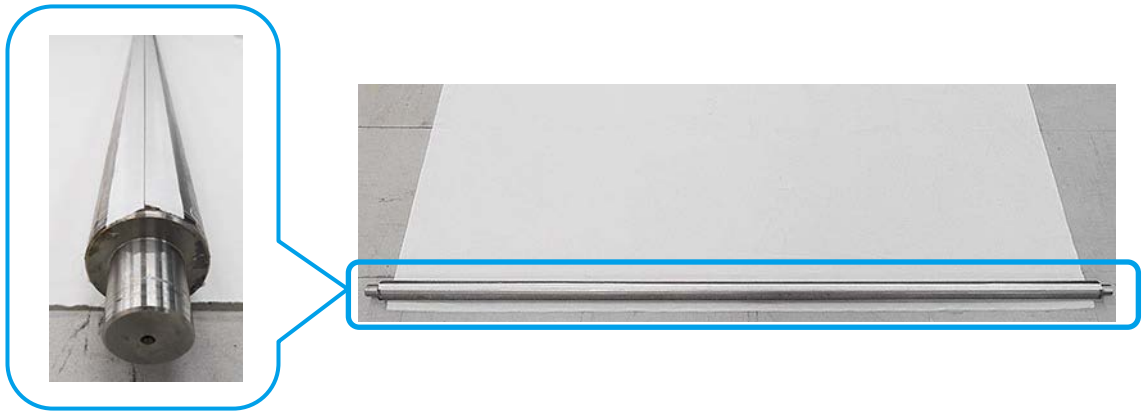

10. (1) Peel off the liner of the tape applied to the towel roller, then (2) press the tape up against the fabric edge to adhere it.

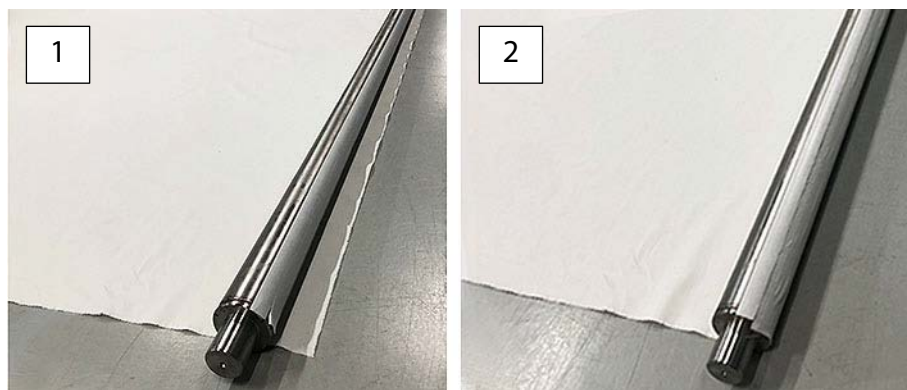

11. Turn the towel roller horizontally to roll up the fabric.

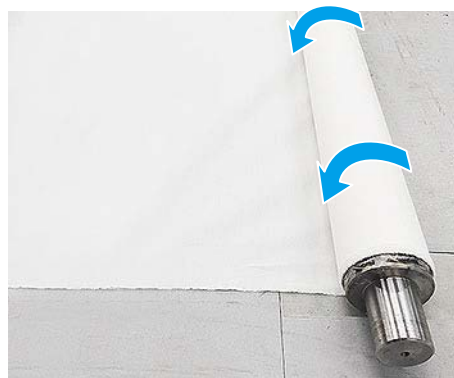

12. When you reach the edge of the fabric, peel off the curing tape and apply double-sided tape to the fabric edge.

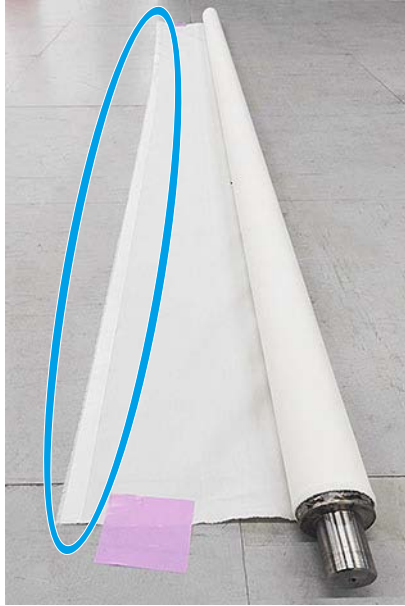

13. Peel off the tape liner, and then adhere the fabric edge to the towel roller.

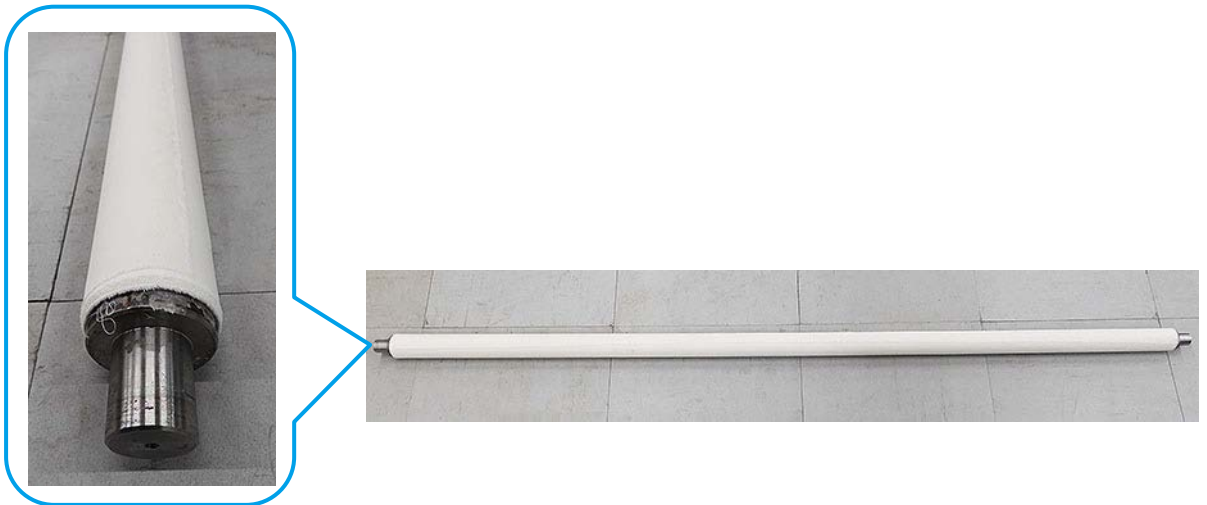

14. Attach the towel roller to this machine.

Firmly hold the towel roller in both hands, and move to the rear of this machine.

15. Align the towel roller shaft with the left and right towel roller grooves, and slowly and horizontally lower it. Place the left and right ends of the shaft on the support screws.

5.4. Washing T-shaped Scraper Replacement

Frequency	When necessary
When to Replace	When the area in contact with the glue belt is worn/deteriorated. If the contacting area is worn/deteriorated, water cannot be wiped off completely after belt cleaning, resulting in water remaining on the belt.
User Permissions	L
Personal Protective Equipment	Protective gloves and clothing
Required Items	Replacement washing T-shaped scraper, two belt cleaning unit wheels, hex key (width: 2.5 mm, 3 mm, 6 mm), spanner (width: 7 mm)

Before starting work, turn off the machine.

1. Turn the left drain valve in the direction of the arrow to close it.

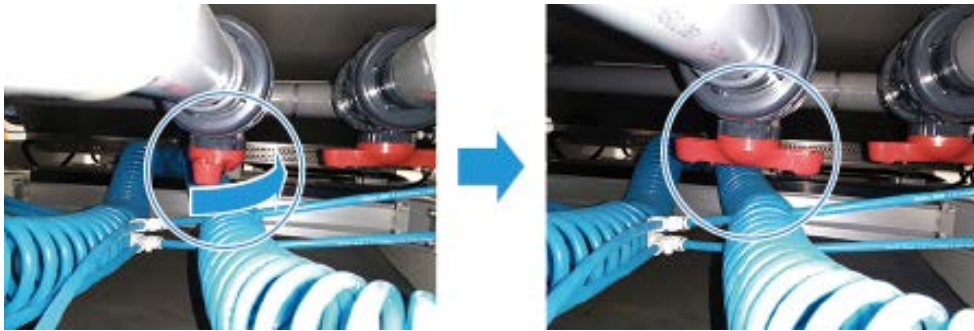

2. Remove the one screw of each fixing block [2] on the left and right using the hex key (width: 6 mm).



Store the removed screws to ensure they are not dropped or placed somewhere they can cause damage.

Right side

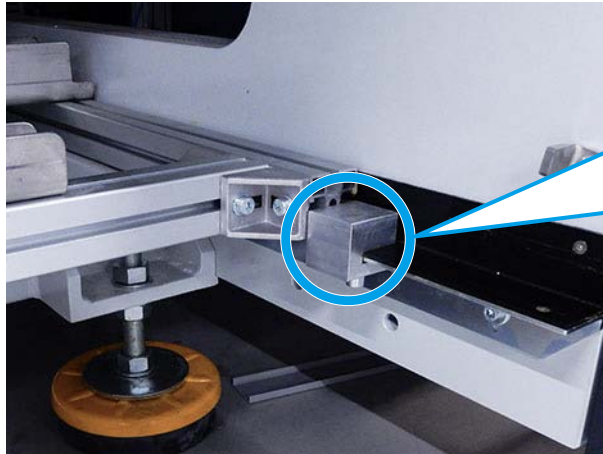

Left side

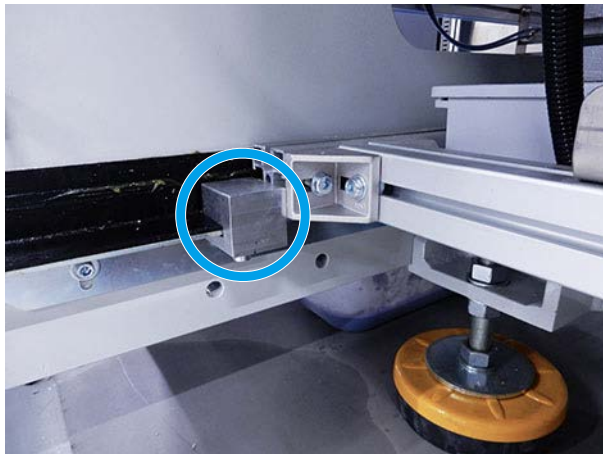

3. Pull the belt cleaning tank toward you until the carriage rail hits the stopper nearest from you.

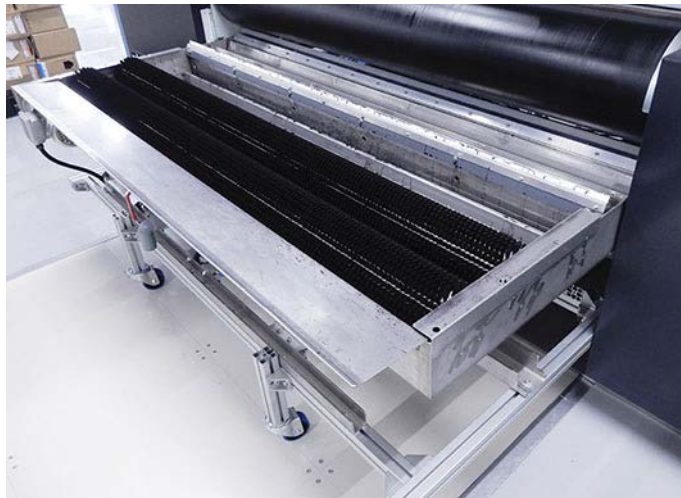

4. Attach the belt cleaning unit wheels on the right and left sides.
5. Remove the stopper and pull out the belt cleaning tank completely.
6. Remove the screw [1] of the fixing plate that secures the washing T-shaped scraper to be replaced using the hex key (width: 3 mm), and remove the fixing plate [2].



Be careful not drop the screw and fixing plate into the cleaning tank.

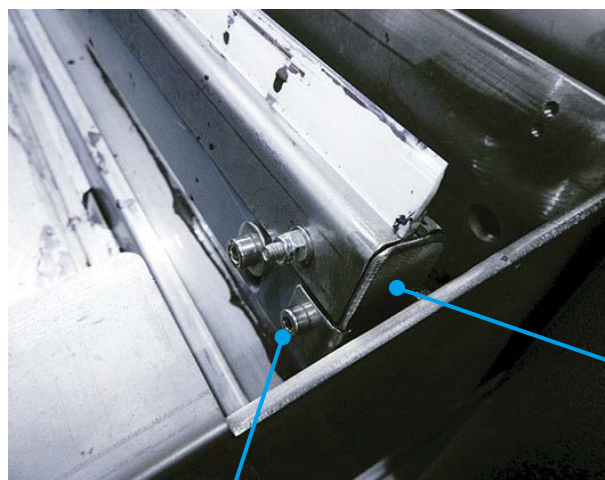

1

2

7. Loosen the screws on both sides of the scraper.

While holding the screw hole behind the screw with the hex key (width: 2.5 mm), loosen the screw with the spanner (width: 7 mm).

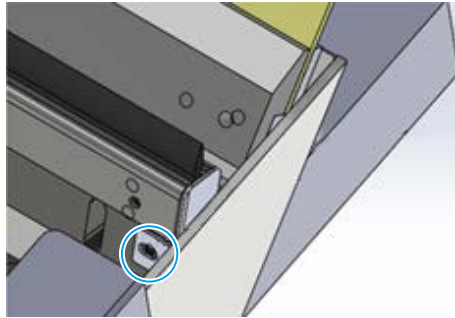

8. Pull out the scraper.

If fluffy dust has become fused, remove it first as the scraper may be stuck when pulled out.

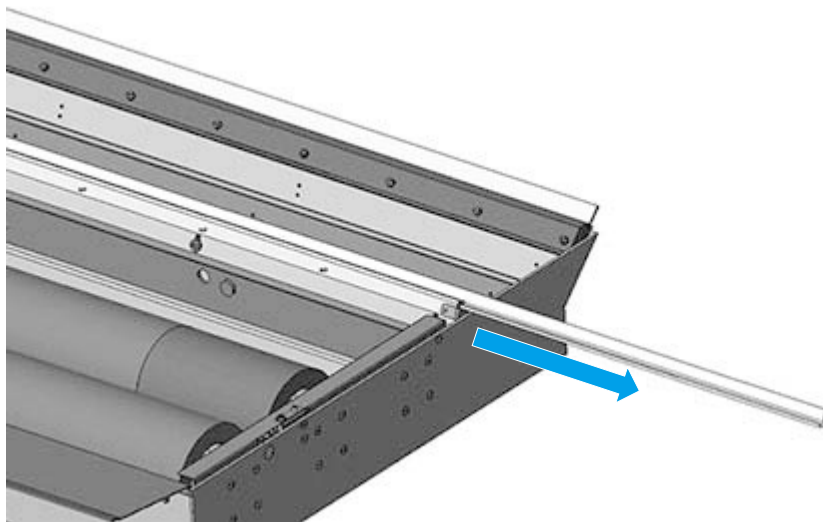

9. Insert a new scraper in the location where the scraper was pulled out.

10. Tighten the screws on both sides of the scraper using the spanner (width: 7 mm) and hex key (width: 2.5 mm).

11. Attach the fixing plate. Secure the screw and fixing plate using the hex key (width: 3 mm).
This completes the replacement procedure.

12. Return the belt cleaning tank to the original position.

Return the belt cleaning carriage to the carriage rail. Attach the stopper and remove the belt cleaning unit wheels.

13. Put the belt cleaning carriage back straight in the original position.
14. Attach the two fixing blocks to the left and right, and tighten the one screw of each using the hex key (width: 6 mm) to secure them.
15. Attach the two fasteners, and tighten the one screw of each using the hex key (width: 3 mm) to secure them.
16. Turn the left drain valve in the direction of the arrow to open it.

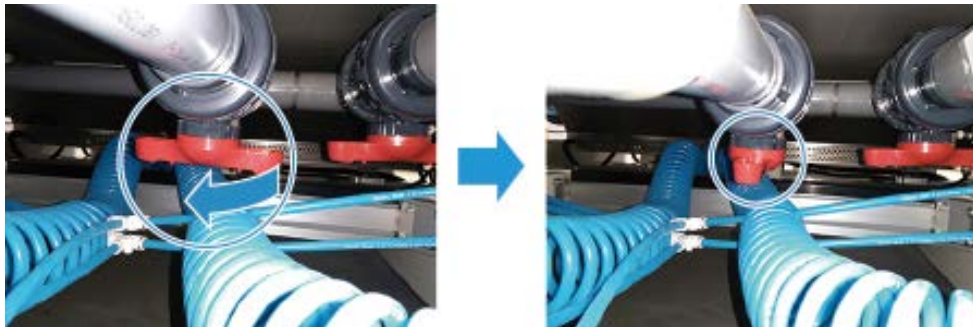

This completes the work.

5.5. Washing Silicone Scraper Replacement

Frequency	When necessary
When to Replace	When the area in contact with the glue belt is worn/deteriorated. If the contacting area is worn/deteriorated, water cannot be wiped off completely after belt cleaning, resulting in water remaining on the belt.
User Permissions	L
Personal Protective Equipment	Protective gloves and clothing
Required Items	Replacement washing silicon scraper, two belt cleaning unit wheels, hex key (width: 3 mm, 4 mm, 6 mm)

Before starting work, turn off the machine.

1. Pull out the belt cleaning tank.
Perform Procedures 1 to 6 in 5.4. (See: 5.4 Washing T-shaped Scraper Replacement)
2. Remove the washing silicone scraper to be replaced.
Loosen the 15 screws that secure the silicon scraper using the hex key (width: 4 mm).
3. Lift out the silicone scraper and attach a new silicone scraper.
4. Return the belt cleaning tank to the original position.
Perform Procedures 13 to 17 in 5.4. (See: 5.4 Washing T-shaped Scraper Replacement)

5.6. Pressure Roller Replacement

Frequency	When necessary
User Permissions	L
Personal Protective Equipment	Protective gloves and clothing
Required Number of Workers	2
Required Items	Replacement pressure roller

1. Operate the button to move the pressure roller toward you and stop it.
2. Operate the button to lift the pressure roller.



3. Press the emergency stop button.
4. Close the Leonardo screen and shut down the PC.
5. Turn the main power switch to 0 (OFF) to turn the power off.
6. Open the rear protection cover.

7. Insert the stopper pins on both sides.

Right side

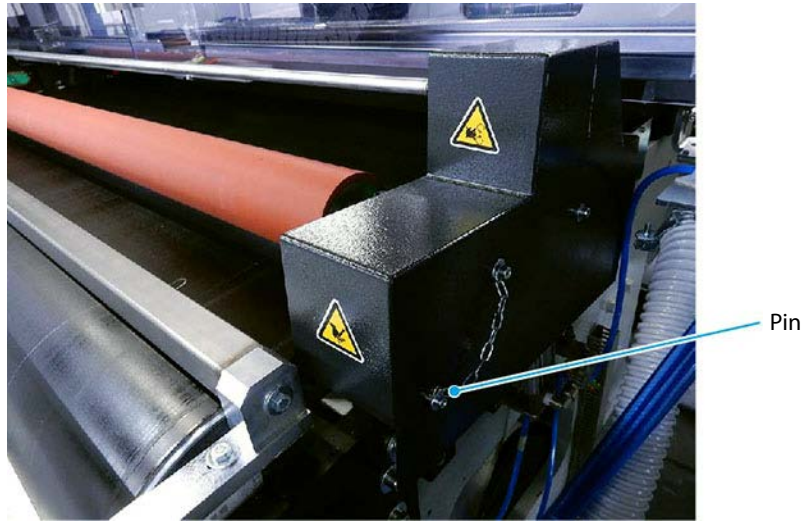

Left side



- Lift the pressure roller vertically to remove it.



CAUTION

Make sure that removal and installation of the pressure roller is performed by two workers due to the weight of the roller.
When lifting a pressure roller, lift with your legs and not your back.







- From the removed pressure roller, remove the two bearings and replace them.
- Attach a new pressure roller.
- Remove the stopper pins on both sides.
- Close the rear protection cover.
- Turn the main power switch to 1 (ON) to turn the power on.
- Start up Leonardo.
- Release the emergency stop button.
- Execute Set point.
Performing Set point causes the pressure roller to automatically come down.

6. Glue Re-Application

6.1. Glue Removal







To remove glue, pour the remover from the rear of the machine to dissolve the glue, and then scrape glue away from the front of the machine.

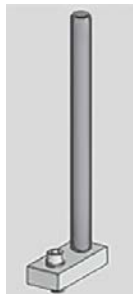

This section describes the procedures for using the glue remover recommended by Epson.









Frequency	When the fabric attached to the belt rises slightly or when there is damage such as peeling of the glue		
User Permissions			
Required Number of Workers	Min. 2 persons		
Personal Protective Equipment	The following is the protective equipment that must be worn when using the glue or glue remover recommended by Epson. For details, refer to the instructions of the SDS for the glue and glue remover you are actually using.		
	Eye protection (For organic solvent use; Optimal is a goggle-type that seals against your face)		
	Gas mask (For organic solvent use)		
	Protective gloves (Butyl or polyurethane)		
	Protective clothing (Long-sleeved)		
	Hair net (Persons with long hair must be tied together with a hair net also worn)		
Safety shoes			

Required Items	Item	Quantity	Details
	Maintenance key	1	Bundled item
	Blade installation part	2	Bundled item



Required Items	Item	Quantity	Details
	Application rod 	1	Bundled item
	Glue collection bucket 	1	Bundled item
	Glue-removal felt 	1 sheet	2 sheets bundled. After these are used, use commercially available felt products of the same size: 190 (Width) x 45 (Length) cm {75 x 18 in}
	Glue remover 	5 L	Recommended product • Cleanser TS (Murayama Chemical Laboratory) • ATR1222 (ATR) • ATR3222 (ATR)
	Ethanol	0.25 L	Commercially available
	Spray bottle (For ethanol) 	1	Commercially available
	Hex key 	1 set	Commercially available
	Wipe cloths (For wiping the belt. Use cloths of soft non-fluffy material that will not damage the belt.) 	Many	Commercially available

Required Items	Item	Quantity	Details
	Bucket for glue 	1	Commercially available
	Cable ties	Approx. 4 ties	Commercially available
	Rubber spatula or plastic spatula (a material that does not dissolve in organic solvents) 	1	Commercially available
	Bags or plastic sheets (a material that does not dissolve in organic solvents)	Proper amount	Commercially available. Used to protect the belt cleaning tank and electric box.

 CAUTION	
    	<p>Wear eye protection, protective gloves, protective clothing, and respiratory protection when performing these procedures.</p> <p>Check the Safety Data Sheet (SDS) for the glue or remover you will actually use for details, and wear the necessary protective gear.</p>
 	<p>- Wear a hat so that your hair does not fall onto the belt.</p>
	<p>Do not use solvents like those below;</p> <ul style="list-style-type: none"> - Chemical (Solvent) - Ketone (Methyl ethyl ketone(MEK)) - Chlorinated hydrocarbon (Methyl chloride, (Mono)chlorobenzene, Trichloroethane, Trichloroethylene) - Ether (Ethyl ether, Tetrahydrofurane(THF))

6.1.1 Preparation

1. Check that the machine is in the Power Off Status.
2. Two persons are required to remove the fabric.
(See: "Set the Fabric" - "Operation Guide".)



CAUTION

Make sure that removal and installation of the fabric roller is performed by two or more workers due to the weight of the fabric.

When lifting the fabric roller, lift with your legs and not your back.



3. Remove the fabric feeding position sensor.

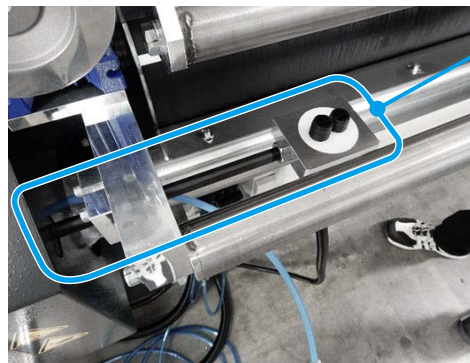

Fabric feeding position sensor

Turn by hand and loosen screw [1] under the sensor and remove the sensor in direction [2].

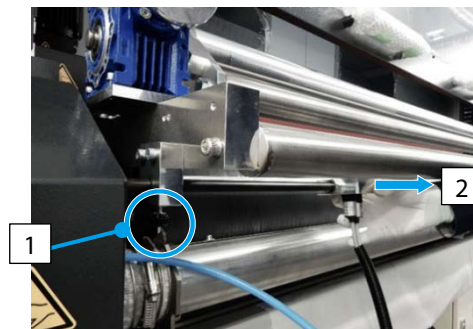

4. Open the rear protection cover.

5. Remove the square rod of the tension roller.

Remove the screws on both ends (1 each) using a spanner (width: 13 mm).

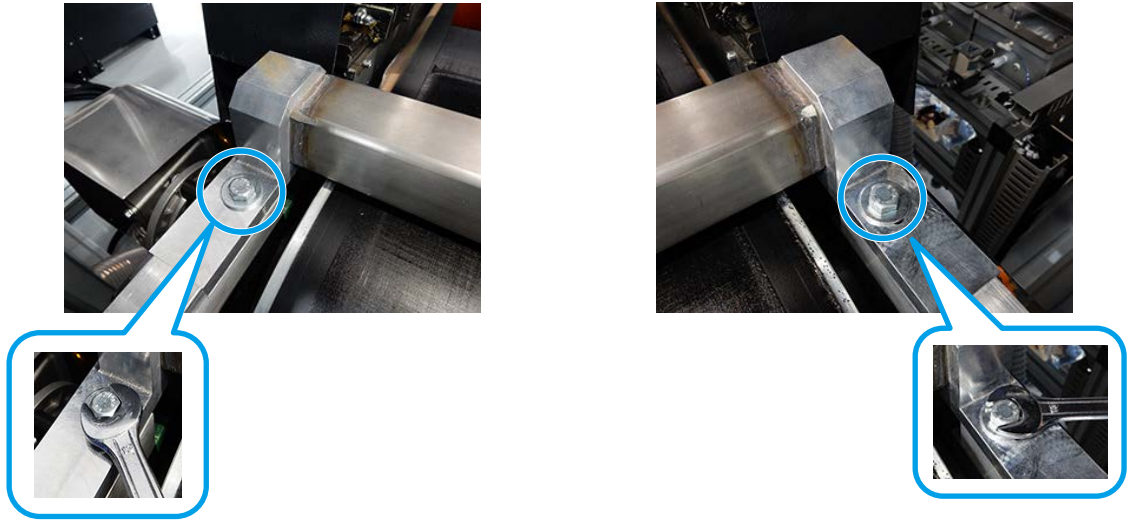

6. Two persons are required to remove the square rod.

7. Remove the tension roller.

Remove the screws on each side of the roller (1 each) using the hex key (width: 5 mm).



8. Two persons are required to remove the tension roller.



9. Remove the catching-prevention cover on the right and left sides of the belt.
Remove the screws (2 each on left and right) of the catching-prevention cover using the hex key (width: 4 mm).

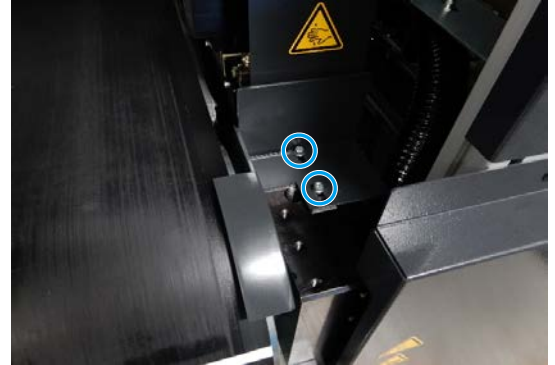
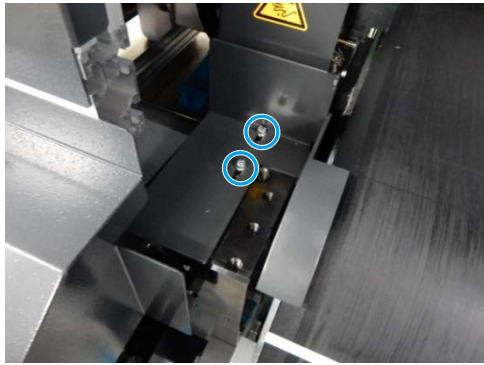

10. Use a spanner (width: 7 mm) to loosen the screw on the blower hose, and remove the blower hose from the blower.

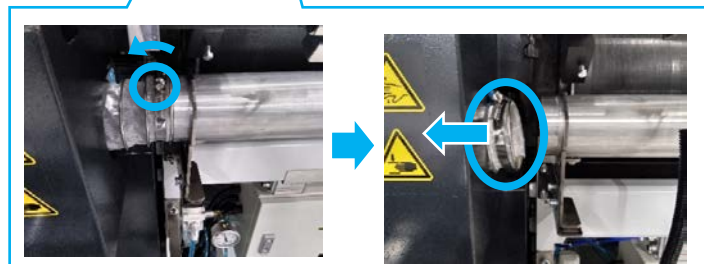

11. Loosen and remove the screws on the blower (4 each) using the hex key (width: 5 mm).

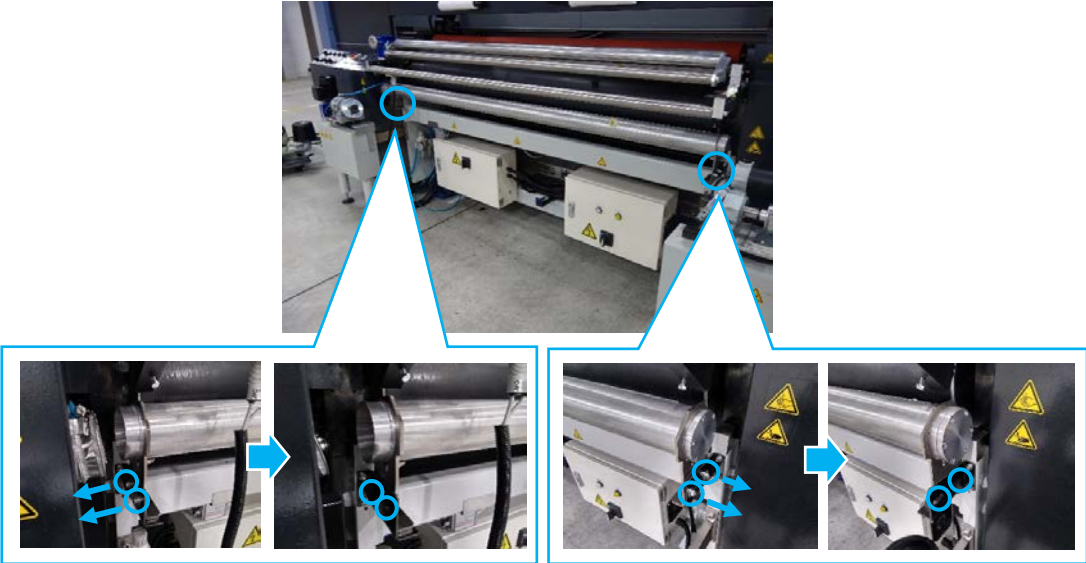

12. With two persons, pull out the blower toward you and remove it.

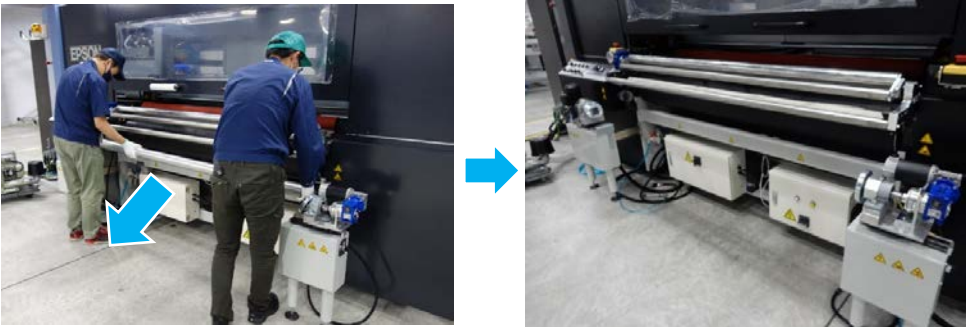

- 13.** Remove the pressure roller.
Lift the pressure roller vertically to remove it.



CAUTION

Make sure that removal and installation of the pressure roller is performed by two workers due to the weight of the roller.

When lifting a pressure roller, lift with your legs and not your back.



- 14.** Move to the front of the machine, and remove the catching-prevention cover on the right and left sides of the belt. Remove the top screws (2 each on right and left) on the catching-prevention cover using the hex key (width: 4 mm), remove the center screws (1 each on right and left) using the hex key (width: 8 mm), and then remove the cover.

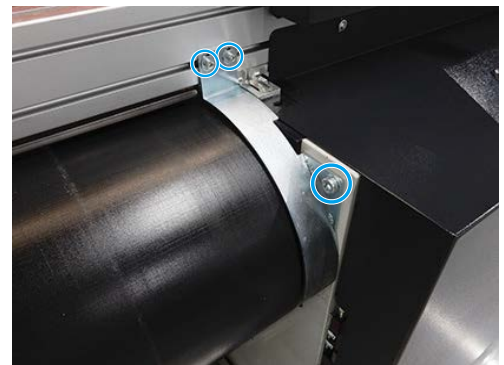
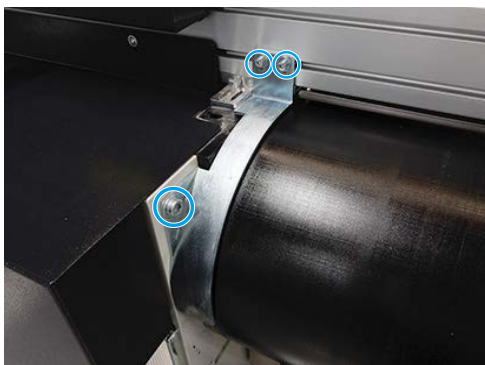

- 15.** Pull out the belt cleaning tank.
Perform Procedures 1 to 6 in 5.4. (See: [5.4 Washing T-shaped Squeegee Replacement](#))

16. Cover the belt cleaning tank and the electric box on the underside of the feeding side, so they do not become soiled by glue or solvents.
Example: Cover them with bags or plastic sheets.
17. Return the belt cleaning tank to the original position.
Perform Procedures 13 to 16 in 5.4. (See: [5.4 Washing T-shaped Squeegee Replacement](#))
18. Move to the rear of the machine, and install the blade installation parts on the right and left.
Install next to the belt and tighten the screws (1 each on right and left) using the hex key (width: 5 mm).



19. Attach the felt to the application rod.



When using commercially available felt:

Sew the ends into bag shapes to make mounting holes, or use cable ties to secure the felt in place after wrapping the felt around the application rod.

Example: Securing the felt with cable ties

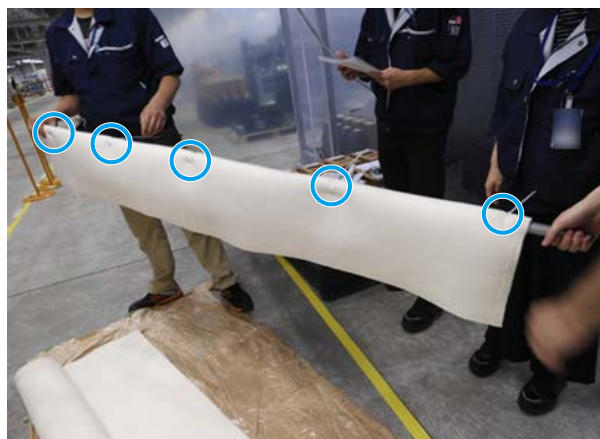

20. Place the application rod on the belt.



21. Secure the application rod and blade installation parts with cable ties.

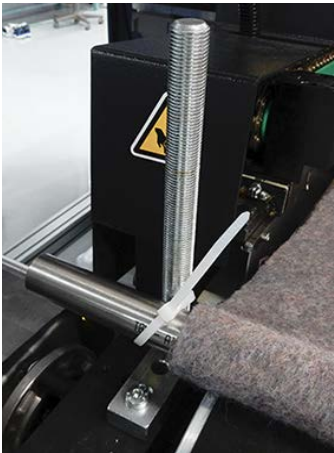

6.1.2 Changing Leonardo to Glue Application Mode

Change to the glue application mode to continuously rotate the belt. In this mode, you can adjust the belt rotation speed using Volume.



CAUTION

Do not insert the maintenance key except for when applying glue. If the maintenance key is inserted, the belt operation safety function is disabled, resulting in a dangerous situation. The maintenance key should be stored by someone who has been authorized by the person in charge at the company. Store it in a safe location that can be locked.

1. Start up Leonardo.
2. Insert the maintenance key in [Maintenance] and turn it to the right.

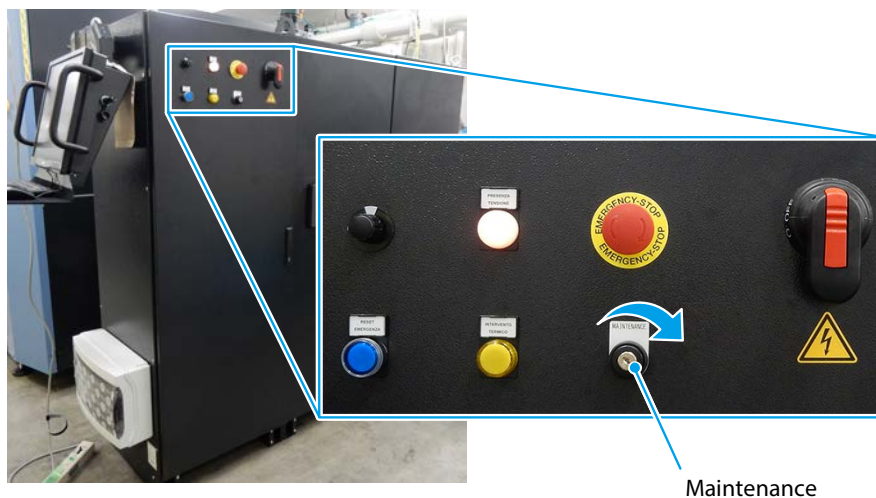

3. Leonardo switches to the glue application mode.

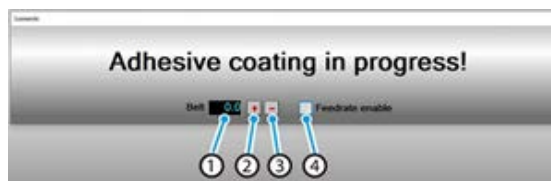

No.	Description
1	Displays the amount of belt running.
2	Feeds the belt in the forward direction.
3	Feeds the belt in the reverse direction.
4	If you select this box, Volume will be enabled, letting you adjust the speed.

During continuous belt feeding, you can adjust the feeding speed using the volume on the rear panel.



6.1.3 Glue Removal

1. Turn the main power switch to 1 (ON) to turn the power on.
2. Set Leonardo to the glue application mode.
3. Pour the glue remover into the glue bucket.
4. Soak the felt with an appropriate amount of remover (approx. 2 L).
Worker 1 (at the rear of the machine): Soak the felt a little at a time so that the remover completely permeates the felt.



5. Set the scale of the volume on the rear panel at 3 to 5, and then place a checkmark for [Feedrate enable] in Leonardo and click [+] to rotate the belt in the forward direction.
6. Gradually soak with the remover until it is uniformly spread.
7. The glue on the belt surface begins to dissolve. Make sure that the glue becomes loose and rises slightly along the entire belt.
8. When the glue rises slightly along the entire belt, start performing glue removal work.
Worker 2: Take the following tools and move to the front of the machine.
Rubber spatula, glue collection bucket

9. Place the rubber spatula against the right edge of the belt at an angle, and scrape away the glue. Catch the glue that is scraped away in the glue collection bucket.

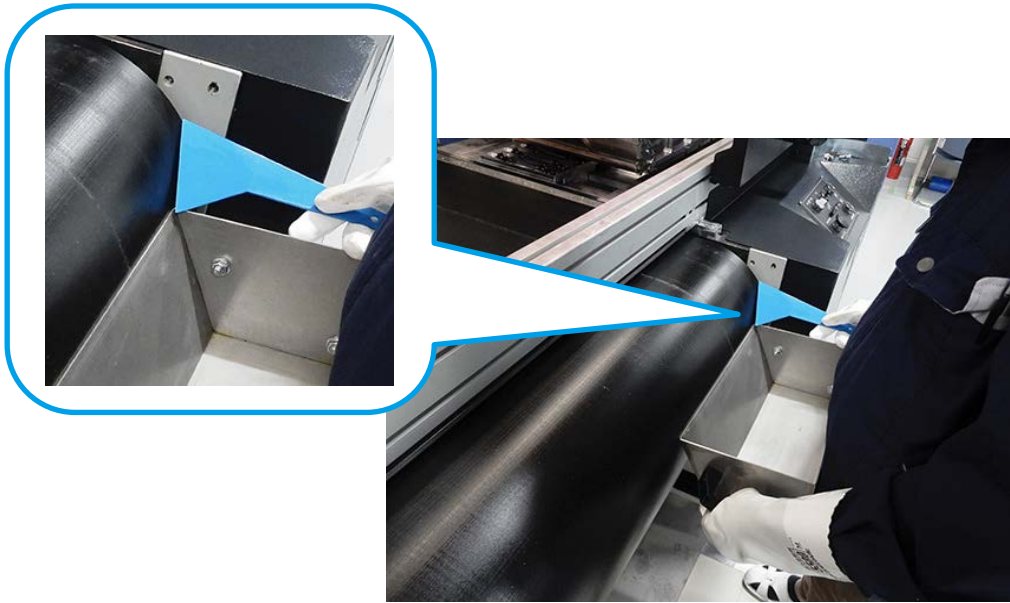

10. When you have finished on the right edge of the belt, remove the glue from all areas of the belt.

Worker 1 (at the rear of the machine): To prevent the remover on the surface of the belt from drying, soak the entire surface of the felt with more remover.

Worker 2 (at the front of the machine): Securely grasp the handles of the glue collection bucket with both hands and press it against the belt surface to scrape away the glue.



CAUTION

Pressing too hard on the glue collection bucket may scratch the surface of the belt.



- 11.** Worker 2: Once most of the glue has been scraped away, gradually move to the left while scraping away glue from all areas of the belt.
Worker 1: While checking the scraping conditions, continue pouring an appropriate amount of remover onto the felt.
- 12.** After scraping away the glue, if there are any areas with hardened glue remaining, use a wipe cloth to remove it.
If the hardened glue cannot be easily removed, soak the felt with remover again to make the hardened glue rise, and then scrape it away.



- 13.** When all glue has been removed, remove the felt.
Dispose of the felt in the proper manner for industrial waste.
- 14.** Click [+] in Leonardo and stop the belt.

6.1.4 Belt Surface Cleaning

1. Check that Leonardo is in the glue application mode, and then place a checkmark for [Feedrate enable] in Leonardo and click [+] to rotate the belt in the forward direction.
2. Use a wipe cloth soaked in ethanol (proper amount) to wipe the belt surface.
3. When the belt surface is completely clean, slowly rotate the belt and wipe clean using an ethanol-soaked cloth.



Completely wipe clean so that no glue remains and the belt is shiny.
Be especially careful that the edges are clean.



4. Click [+] in Leonardo and stop the belt.

6.1.5 Clean-Up





Use wipe cloths or similar to absorb any waste chemicals, and then dispose of them in the proper manner for industrial waste.

Next, perform glue application (6.2 Glue Application).







6.2. Glue Application

Glue application work is performed at the rear of the machine.









This section describes the procedures for using the glue recommended by Epson.

Frequency	When the fabric attached to the belt rises slightly or when there is damage such as peeling of the glue		
User Permissions			
Required Number of Workers	Min. 2 persons		
Personal Protective Equipment	The following is the protective equipment that must be worn when using the glue or glue remover recommended by Epson. For details, refer to the instructions of the SDS for the glue and glue remover you are actually using.		
	Eye protection (For organic solvent use; Optimal is a goggle-type that seals against your face)		
	Gas mask (For organic solvent use)		
	Protective gloves (Butyl or polyurethane)		
	Protective clothing (Long-sleeved)		
	Hair net (Persons with long hair must be tied together with a hair net also worn)		
	Safety shoes		

Required Items	Item	Quantity	Details
	Blade installation part 	2	Bundled item

Required Items	Item	Quantity	Details
	Blade (For glue application) 	1	Bundled item
	Glue application blocks 	2	Bundled item
	Bucket for glue 	2	Commercially available
	Scale	1	Commercially available
	Scissors	1	Commercially available
	Stirring rod for preparing glue	1	Commercially available
	Hex key 	1 set	Commercially available
	Glue (1st layer): ATR1945 (ML/T)	1.6 kg	Recommended product
	Glue (2nd layer): ATR1946 (ML/S)	0.8 kg	Recommended product
	Glue (2nd layer): ATR1947 (ML/K)	0.8 kg	Recommended product
	Ethanol	0.25 L	Commercially available
	Spray bottle (For ethanol) 	1	Commercially available
	Insulating tape (thickness: 0.2 mm) (Recommended: 0.2 mm (thickness) x approx. 19 mm (width) x 10 m (length))	2	Commercially available. Be sure to use tape with a thickness of 0.2 mm, because this will be the gap between the blade and the belt when applying glue.
	Soapy water	Proper amount	Commercially available
	Cleaning bottle (For soapy water) 	1	Commercially available

Required Items	Item	Quantity	Details
	Wipe cloths (For wiping the belt. Use cloths of soft non-fluffy material that will not damage the belt.) 	Many	Commercially available

 CAUTION	
    	<p>Wear eye protection, protective gloves, protective clothing, and respiratory protection when performing these procedures.</p> <p>Check the Safety Data Sheet (SDS) for the glue or remover you will actually use for details, and wear the necessary protective gear.</p>
 	<p>- Wear a hat so that your hair does not fall onto the belt.</p> <p>- Long hair should be tied back and worn under a hair net.</p>

6.2.1 Preparation

1. Check that Leonardo is in the glue application mode, and then place a checkmark for [Feedrate enable] in Leonardo and click [+1] to rotate the belt in the forward direction.
2. Clean the belt surface. Use a wipe cloth soaked in ethanol (proper amount) to wipe the belt surface clean while slowly rotating the belt.



3. After it has been wiped completely clean, use compressed air from the air compressor on the rear of the machine to remove dust and other foreign material adhering to the surface.



4. Affix the insulating tape (mending tape) to both edges of the belt. Affix insulating tape completely around the belt. Stop rotating the belt so that the corners of the insulating tape contact the edges of the belt.



5. Slowly rotate the belt so that it is affixed completely around the belt.



If the tape is floating up, friction with the blade could cause the tape to tear during glue application.

If the tape tears, the glue cannot be applied uniformly; therefore, the glue must be reapplied.

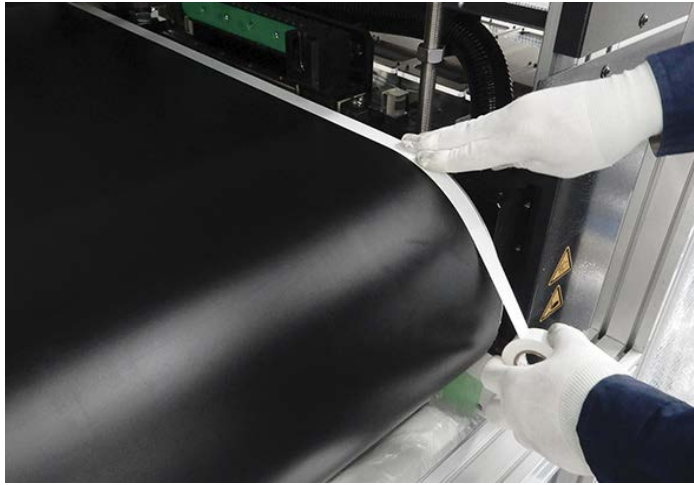

6. Stop rotation of the completely affixed belt and overlap the tape seams by about 5 to 10 mm.

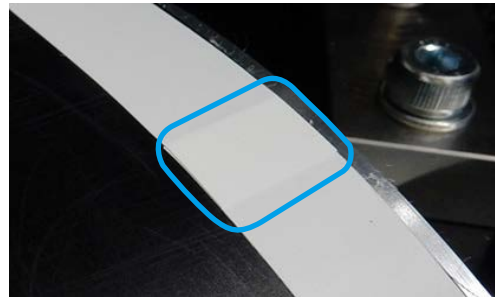
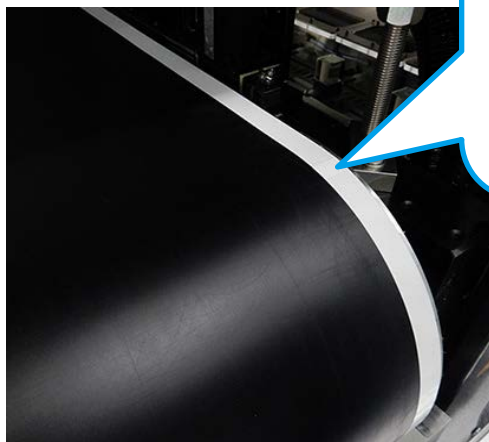

7. Slowly rotate the belt again while checking there is no foreign material adhering to the belt and remove any that is found.

8. Install the blade.

Two persons are required to carry the blade to the rear of the machine.



Do not place the blade on the floor with the sharp edge facing down, or bump it against other objects.

Doing so could damage the sharp edge. A damaged blade will not apply glue uniformly.

9. Align the holes on each end of the blade with the supports on the blade installation parts, and slowly and evenly lower the blade on both right and left sides to avoid damaging the belt.

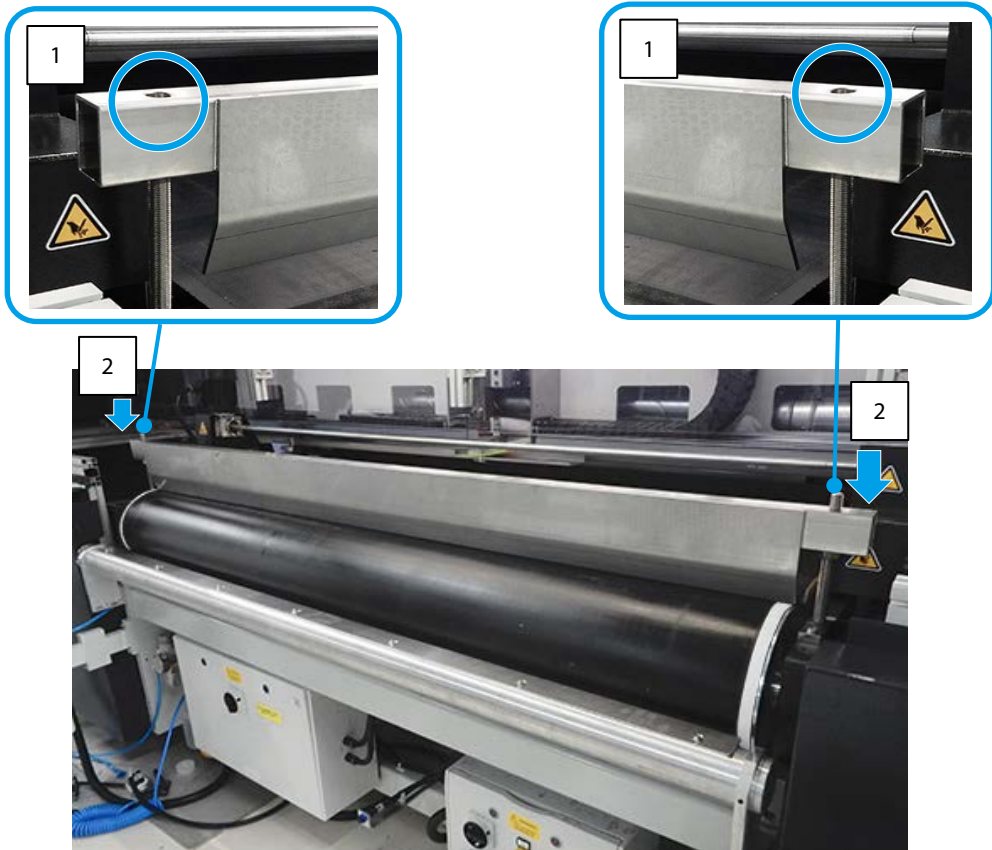

10. Rotate the belt a little in the forward direction and stop.
This operation sets the blade at a slight angle against the belt. This completes the blade installation procedure.

- 11.** Place one glue application block in a position 5 mm from the inner side of the insulating tape applied to each end of the belt.

When placing the blocks, do not place them on the seams of the insulating tape applied to both sides of the belt. If the seams of the insulating tape come where you want to place the blocks, feed the belt to where there are no seams.

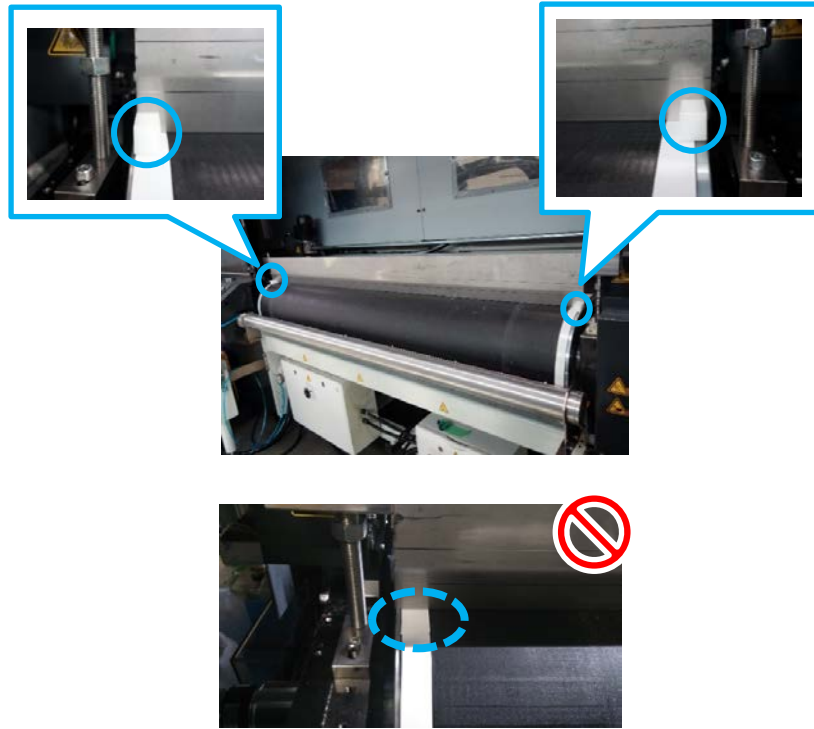

- 12.** Affix the glue application blocks to both ends of the blade using insulating tape so that there are no gaps in the following:

- Between the block and the belt
- Between the block and the blade





CAUTION

Do not affix the blocks in the states described below. There is a risk that the glue may not be applied evenly, or the glue may leak from the belt edge into the machine, causing a malfunction.

- There is a gap between the block and the belt.



- There is a gap between the block and the blade.

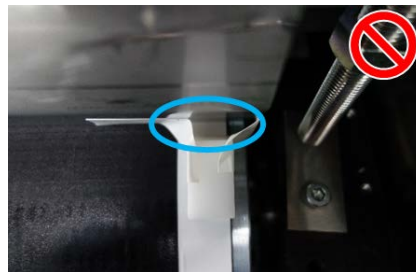

- The block is slanted.



6.2.2 Glue Preparation

1. Prepare the glue for the first layer.
Set the glue bucket on the scale and pour in the glue (ATR1945 (ML/T), 1.6 kg).
2. Mix the two glue types to prepare the 2nd-layer glue.
Set a glue bucket different from step 1 on the scale and pour in the second glue type (ATR1946 (ML/S), 0.8 kg).
Pour in the third glue type (ATR 1947 (ML/K), 0.8 kg) and blend them together using the rod.

6.2.3 Glue Application (1st Layer)

1. Set Leonardo to the glue application mode.
2. Rotate the belt in the forward direction.
Set the scale of the volume on the rear panel at 4 to 6, and then place a checkmark for [Feedrate enable] in Leonardo and click [+] to rotate the belt in the forward direction.
3. Apply the 1st-layer glue. Pour a proper amount of glue to right next to the blade.
Pour so that the glue flows from the center to both edges.



It is not necessary to pour all of the glue at once.

As the glue accumulates in front of the blade, rotate the belt to apply glue slowly to the belt surface through the gap between the blade and belt. As the glue decrease, pour in a proper amount of more glue.



4. When the 1st-layer glue has been completely poured in, prepare the 2nd-layer glue.

6.2.4 Glue Application (2nd Layer)

1. Maintain the belt rotation speed as it is, and when the 1st-layer glue has all been used, pour the 2nd-layer glue.

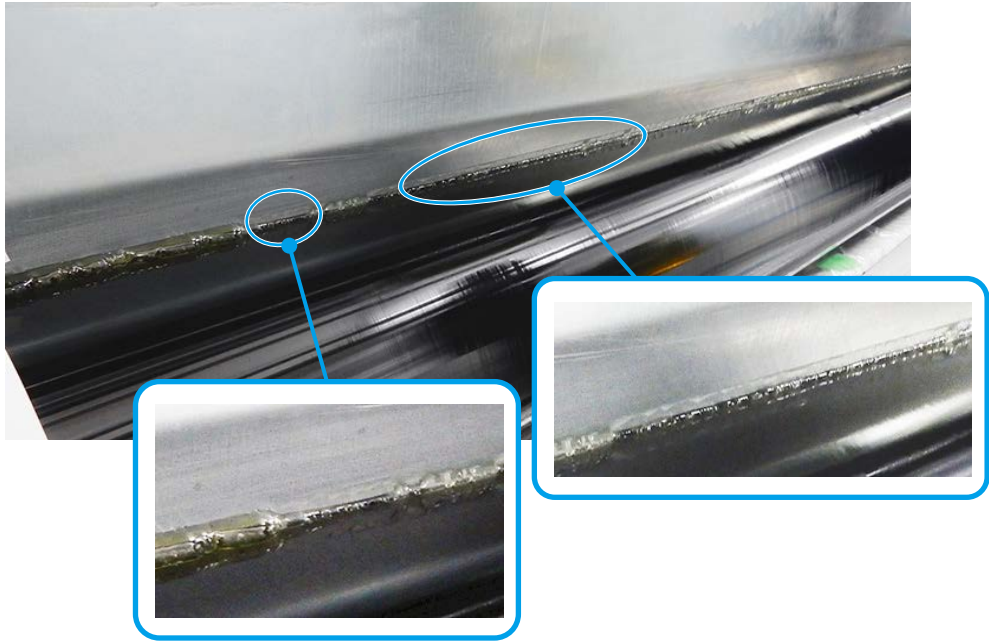

It is not necessary to pour all of the glue at once. Pour a small proper amount of time to the same area as the 1st layer.



2. After it has been completely poured, prepare the soapy water, when the 2nd-layer glue has all been used, spray the soapy water. The soapy water creates a water repellent membrane on the belt surface so that the glue and blade can be easily separated.

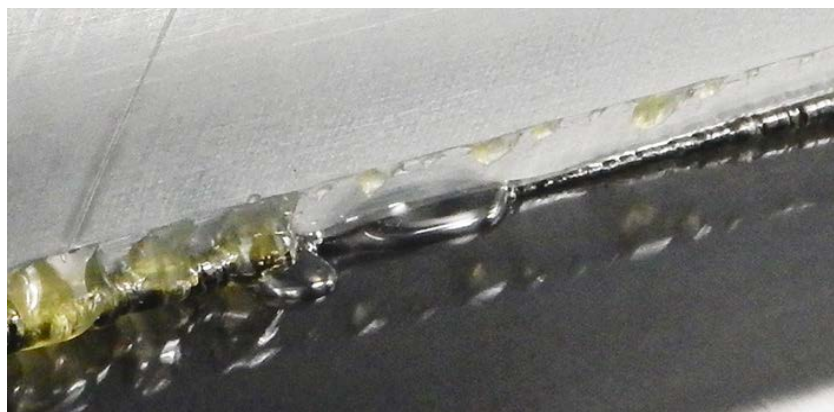
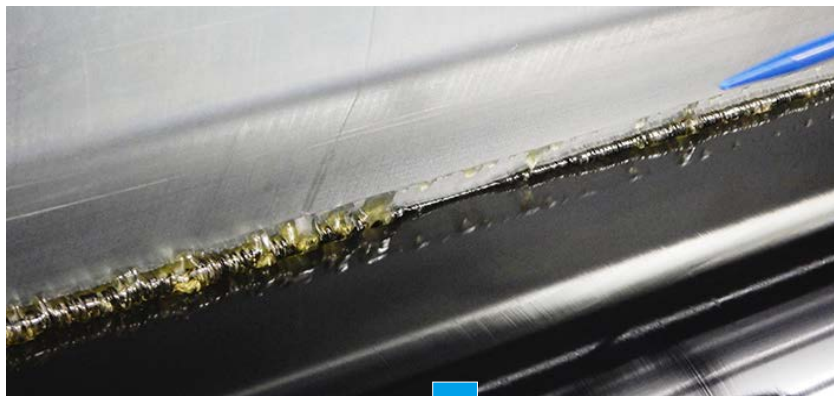

3. Check that the glue accumulated in front of the blade has been completely used and soapy water is completely applied.

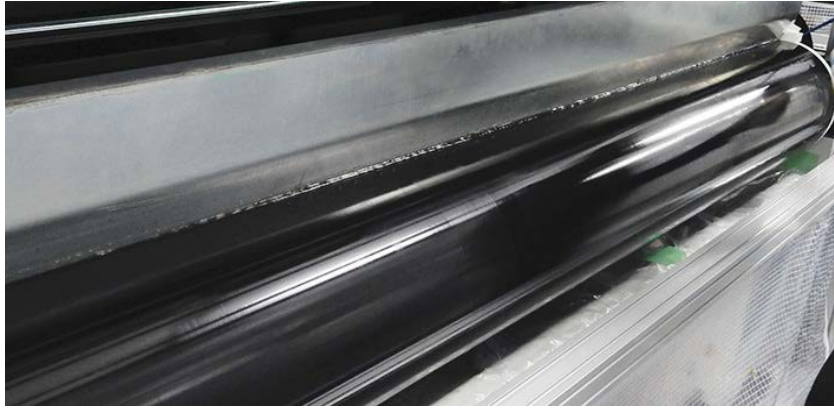

6.2.5 Blade Removal

1. Two persons are required to lift the blade evenly on both right and left sides, and remove it.



Be careful that the blade does not contact the belt surface when removing it.



2. Wipe the blade, glue application blocks, and buckets clean using ethanol.
3. Use wipe cloths or similar to absorb any waste solvents, and then dispose of them in the proper manner for industrial waste.

6.2.6 Drying

1. Stop belt rotation and use a wipe cloth to wipe off any water drops (soapy water) remaining on the belt surface. Be careful not to damage the belt.
2. Rotate the belt in the forward direction for two hours at the same speed as that used for application.
3. Stop the belt and then cancel the glue application mode on Leonardo.
4. Allow to dry for 10 hours or more.

6.2.7 Work After Application

1. Set Leonardo to the glue application mode.
2. After application, leave for 10 hours or more, and then remove the insulating tape. Peel off the insulating tape from the end, and hold the tape while slowly rotating the belt in the forward direction to completely remove it.

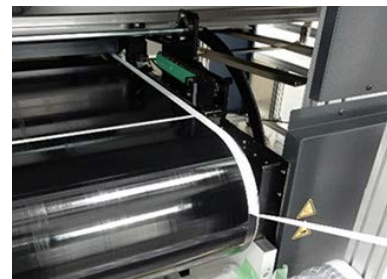
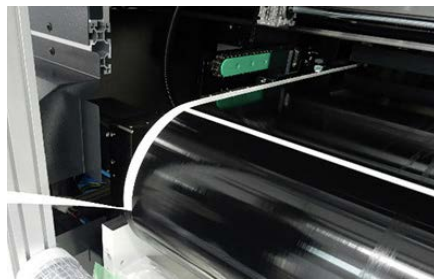

3. Check the entire belt for any foreign material.
4. Stop the belt and then cancel the glue application mode on Leonardo.



CAUTION

Do not insert the maintenance key except for when applying glue. If the maintenance key is inserted, the belt operation safety function is disabled, resulting in a dangerous situation. The maintenance key should be stored by someone who has been authorized by the person in charge at the company. Store it in a safe location that can be locked.

5. Pull out the belt cleaning tank.
Perform Procedures 1 to 6 in 5.4. (See: [5.4 Washing T-shaped Squeege Replacement](#))
6. Remove the protection material (bags or plastic sheets) from the belt cleaning tank and electric box.
If there is any organic solvent adhered to the protection material, dispose of the protection material in the proper manner for industrial waste.

7. Return the belt cleaning tank to the original position.
Perform Procedures 13 to 16 in 5.4. (See: [5.4 Washing T-shaped Squeegee Replacement](#))
8. Install the catching-prevention covers on the right and left sides of the belt.
Install the catching-prevention covers, and secure them by tightening the top screws (2 each on right and left) using the hex key (width: 4 mm) and the center screws (1 each on right and left) using the hex key (width: 8 mm).
9. Move to the rear of the machine, and remove the blade installation parts.
Loosen the screws (1 each on right and left) using the hex key (width: 5 mm) to remove them.
10. Install the catching-prevention covers on the right and left sides of the belt.
Install the catching-prevention covers, and tighten the screws (2 each on right and left) using the hex key (width: 4 mm).
11. Two persons are required to install the pressure roller.



CAUTION

Make sure that removal and installation of the pressure roller is performed by two workers due to the weight of the roller.
When lifting a pressure roller, lift with your legs and not your back.

12. With two people, place the blower as indicated in the figure, with the connecting port for the blower hose on the rear left side.

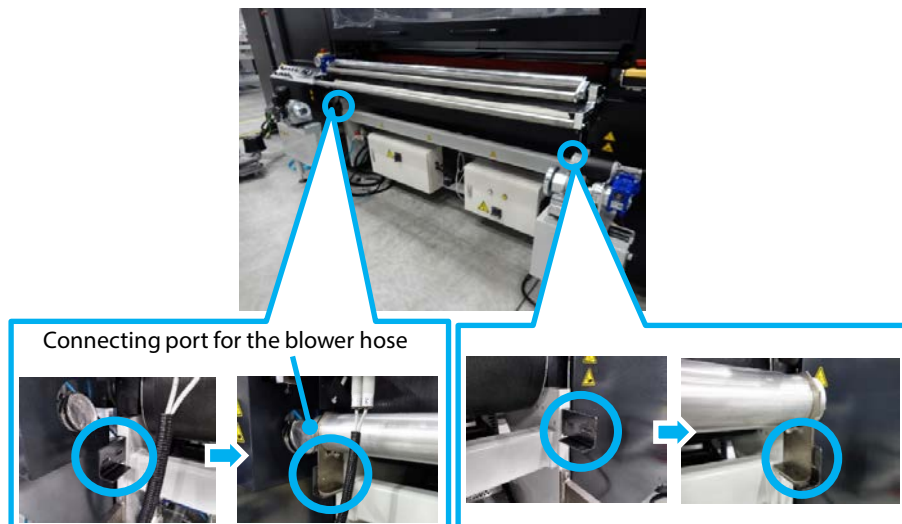

13. Align the screw holes on the blower and the screw holes on the machine as indicated in the figure.

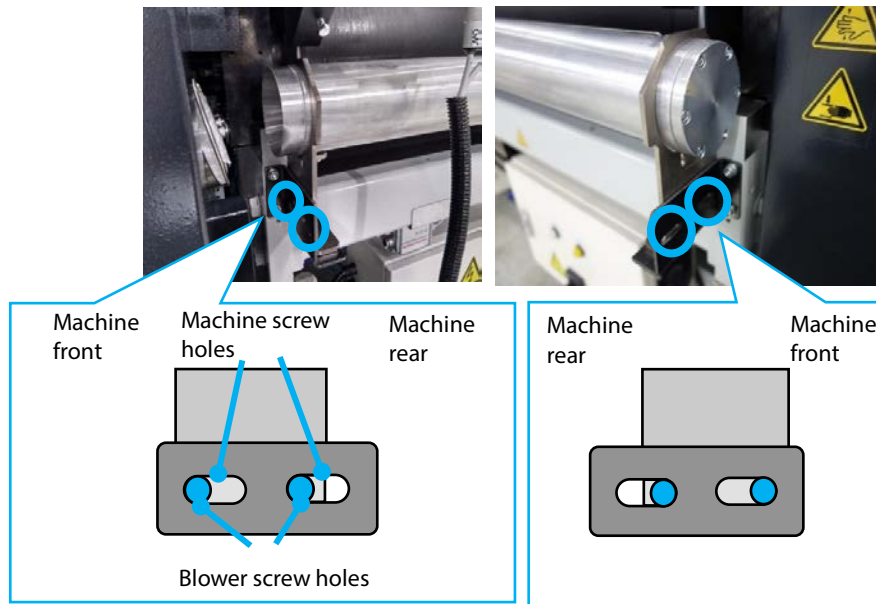

14. Tighten the screws on the blower (4 each) using the hex key (width: 5 mm).

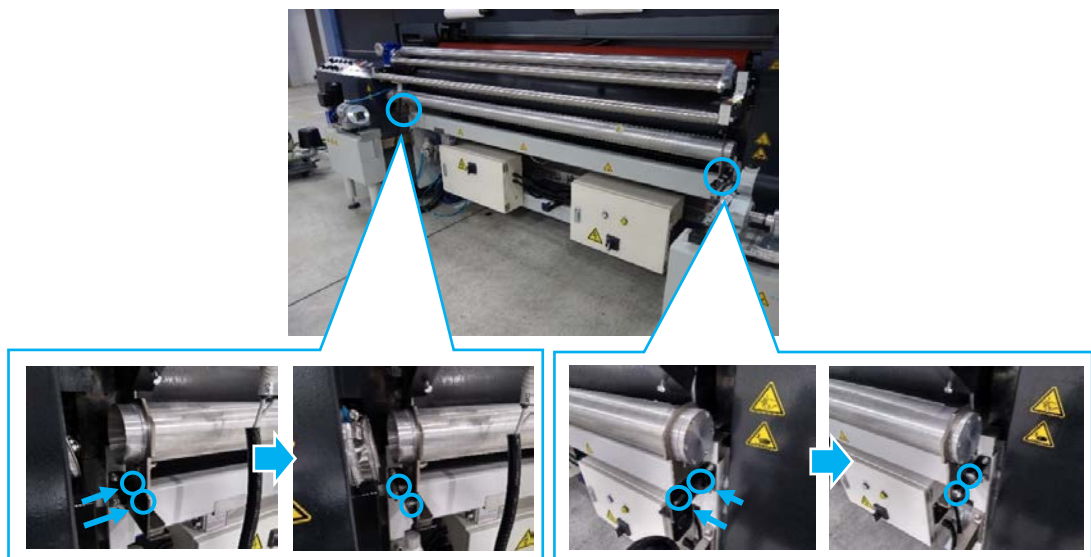

- 15.** Cover the blower with the blower hose, up to the position indicated in the figure.

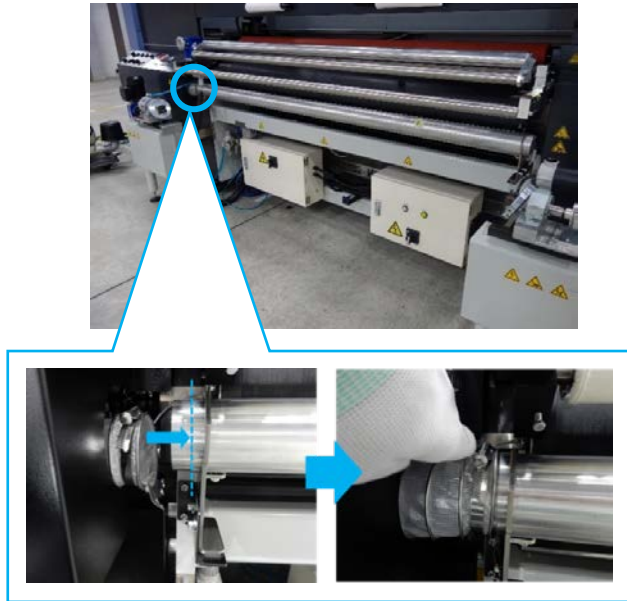

- 16.** Use a spanner (width: 7 mm) to tighten the screw on the blower hose.

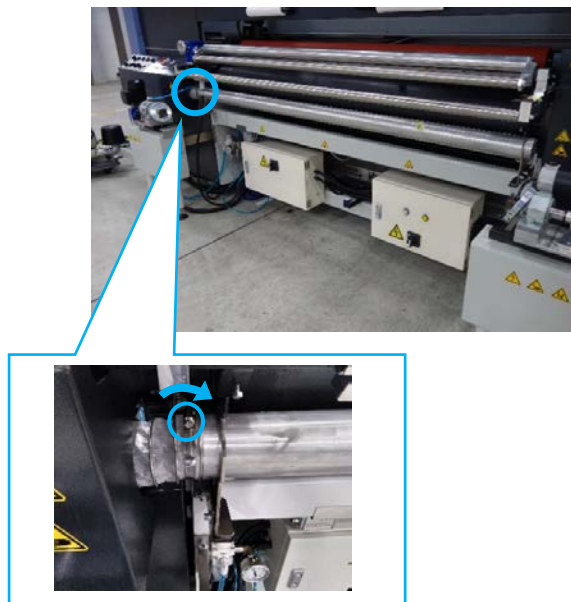

- 17.** Attach the tension roller.
Use two persons to attach the tension roller in the original position. Tighten the screws on each side of the roller (1 each) using the hex key (width: 5 mm).
- 18.** Attach the square rod of the tension roller.
Use two persons to attach the square rod in the original position. Tighten the screws on each ends of the roller (1 each) using a spanner (width: 13 mm).
- 19.** Attach the fabric feeding position sensor.
Return the sensor to the original position, and tighten the screw on the bottom of the sensor by hand.

- 20.** Use two persons to attach the fabric.
(See: "Set the Fabric" - "Operation Guide".)



CAUTION

Make sure that removal and installation of the fabric roller is performed by two or more workers due to the weight of the fabric.

When lifting the fabric roller, lift with your legs and not your back.

- 21.** Close the rear protection cover.

This completes the work.