

EVO TRE Series

Operation Guide

Safety and Accident Prevention

Specifications

Name and Function of Each Part

Workflow before Beginning Work

Print Workflow

Workflow When Turning Off the Power

Troubleshooting



Cautions

- No part of this publication may be reproduced, stored in a retrieval system, or transmitted in any form or by any means, electronic, mechanical, photocopying, recording, or otherwise, without the prior written permission of Seiko Epson Corporation.
- No patent liability is assumed with respect to the use of the information contained herein.
- While every precaution has been taken in the preparation of this book, Seiko Epson Corporation assumes no responsibility for errors or omissions.
- Neither is any liability assumed for damages resulting from the use of the information contained herein.
- Neither Seiko Epson Corporation nor its affiliates shall be liable to the purchaser of this product or third parties for damages, losses, costs, or expenses incurred by purchaser or third parties as a result of: accident, misuse, or abuse of this product or unauthorized modifications, repairs, or alterations to this product, or (excluding the U.S.) failure to strictly comply with Seiko Epson Corporation's operating and maintenance instructions.
- Seiko Epson Corporation shall not be liable against any damages or problems arising from the use of any options or any consumable products other than those designated as Original Epson Products or Epson Approved Products by Seiko Epson Corporation.

Trademarks

Microsoft[®] and Windows[®] are either registered trademarks or trademarks of Microsoft Corporation in the United States and other countries.

Adobe and Photoshop are trademarks or registered trademarks of Adobe Systems Incorporated in the United States and other countries.

All other trademarks are the property of their respective owners and used for identification purpose only.

Images Used in this Manual

The images used in this document may vary from your machine. Unless otherwise stated, this document uses images of the EVO TRE 16-180.

©Seiko Epson Corporation 2020–2023

About this manual

This manual applies to the following models:

- EVO TRE 8-180
- EVO TRE 16-180
- EVO TRE 16-220
- EVO TRE 16-320
- EVO TRE 32-180
- EVO TRE 32-220
- EVO TRE 32-320

Contents

■ About this manual	3
■ Contents.....	4

Safety and Accident Prevention..... 8

■ Important Safety Information	8
Meaning of Symbols	8
Warning Labels	11
■ Safety Information	16
General Precautions	16
Handling Precautions	18
Cautionary Information Regarding Consumables (Ink, Maintenance Liquid) and Waste Ink	19
Handling Precautions for Ink Cartridges.....	20
■ Emergency Stop and Pause.....	22
Emergency Stop	22
Pause.....	22
■ Standards and Approvals	23
For Users in Europe.....	23

Specifications..... 25

■ Basic Specifications	25
EVO TRE 8	25
EVO TRE 16.....	26
EVO TRE 32.....	27
■ Resolution/Number of Passes and Print Speed.....	28
EVO TRE 8	28
EVO TRE 16.....	29
EVO TRE 32.....	31
■ Printing Width.....	33
■ Elevation	33
■ Power.....	34
EVO TRE 8	34
EVO TRE 16.....	35
EVO TRE 32.....	36
■ Supported Ink.....	38
3L.....	38
10L.....	41

■ Ink Cartridges	44
Ink Cartridges (3L).....	44
Ink Cartridges (10L)	44
■ Consumables	46
Consumables (3L).....	46
Consumables (10L)	46

Name and Function of Each Part 47

■ Name of Major Parts	47
■ Name of Each Part.....	49
■ Tower Lamps and Rotary Beacon.....	54
■ Ink rack (3L)	55
Inside of ink tank	56
■ Ink rack (10L).....	57
■ Control Panel	58

Workflow before Beginning Work..... 62

■ Workflow.....	62
■ Checking the Air Pressure	63
■ Removing the Stopper Pin of the Pressure Roller.....	64
■ Lowering the Towel Roller	65
■ Supply Water to and Check the Belt Cleaning Unit	67
Opening the Water Supply Valve.....	67
Belt Checking the Belt on the Cleaning Unit.....	67
■ Check the Amount of Waste Ink Remaining in the Waste Ink Tank	68
■ Prepare the Fabric	69
■ Adjusting the Fabric Peeling Prevention Bar	70
■ Checking Operating Parts	74
■ Checking the Exhaust Equipment	75
■ Pushing an Emergency Stop Button for an Emergency Stop	76
■ Turning On the Power	76
■ Starting Leonardo	77
■ Releasing an Emergency Stop Button.....	78
■ Executing Set Point.....	79
■ Check the Operation of the Emergency Stop Equipment	80
Checking the Emergency Stop Buttons on the Machine.....	80
Checking the Emergency Stop Functions in the System.....	80

■ Inspect for Leaks in the Ink Path	81
■ Inspect the Open Cover Detection	83
■ Nozzle Check.....	84
Setting the Acrylic Board.....	84
Printing the Nozzle Check Pattern	85
Confirmation Method.....	86
■ Head Cleaning	87
Cleaning with Leonardo	87

Print Workflow 89

■ Workflow.....	89
■ Set the Fabric	90
Installing the Fabric.....	90
Slack Mode	96
Fabric Meandering Correction	102
■ Set the Foreign Material Detection Sensor	108
How to Set the Foreign Material Detection Sensor	109
■ Set the Printer	111
Set the Fabric Thickness and Head Height.....	111
Set the Printer Equipment and Sensors	113
■ Load the Print Data	114
■ Set the Print Data	116
■ Printing	118
Checking the Status of the Fabric	118
Checking the Print Path	118
Checking the Ink.....	118
Configuring the Print Settings.....	118
Print.....	119
Checking the Cleaning Unit	119
Printing Ends.....	119
■ Stopping Printing.....	120
■ Replace the Ink	121
Checking the Amount of Ink.....	121
Replace the Ink (3L)	122
Replace the Ink (10L).....	129
■ Changing User Permissions	134
■ Check the Belt Cleaning Unit Operation.....	135

Workflow When Turning Off the Power..... 136

■ Inserting the Stopper Pin of the Pressure Roller	137
--	-----

■ Lifting Up the Towel Roller	138
■ Cleaning	140
Wipers and Caps	140
Flushing Plate	140
Belt (When Using Pigment Ink)	140
■ Exiting Leonardo	140
■ Turning Off the Control PC	140
■ Emergency Stop by Use of an Emergency Stop Button	141
■ Turn off the Main Power	141
■ Closing the Water Supply Valve on the Belt Cleaning Unit	142

Troubleshooting..... 143

Error Messages	143
Print Quality	147
Manual flushing	147
Print Head Failure	148

Safety and Accident Prevention

This section provides information regarding safety and accident prevention.

Important Safety Information

This manual provides important safety information, describes the symbols that are used both in this manual and on this machine, and explains the basic procedures for operating this machine.

Be sure to read this manual carefully before using this machine. Store this manual in a safe location where it can be easily referred to whenever you have a question.

For more information about maintenance procedures and how to troubleshoot common problems, refer to the “Maintenance Guide”.



Online manuals are available from qualified service personnel.



Meaning of Symbols





The following warning symbols are used in this manual and on this machine to indicate hazardous operations, to ensure that this machine is used safely and correctly in order to prevent injury to the user and other persons and damage to property.

Please carefully read and understand these warnings before using this machine.

Symbols in This Manual

 WARNING	This symbol indicates that incorrect operation could result in death or serious injury.
 CAUTION	This symbol indicates that incorrect operation could result in injury and/or damage to property.
	This symbol indicates a supplementary explanation or additional information that the user should know.





	<p>This symbol indicates user permissions for general users who have been trained in the operation of the machine, to perform machine normal operation, cleaning, and simple maintenance procedures while protective devices are engaged and using the button panel.</p> <p>"L" profile to the person assigned to normal operation of the machine.</p>
	<p>This symbol indicates user permissions for general users who have been officially trained in the operation of this machine, to perform some functions and maintenance procedures that are allowed in addition to all of the functions for L.</p> <p>"H" profile to the person assigned to the periodic supervising operations, who holds the activation keys for the selectors and is authorized to occasionally operate the jog controls.</p> <p>The user is required to acquaint the operators about the information contained in this manual and to always have the manual accessible for reference.</p> <p>The same is true for the operators assigned to checks and maintenance, both routine or extraordinary and only if qualified by specific Epson training.</p> <p>Operators are required to understand and adhere to company safety rules, general accident prevention standards, and health and safety regulations.</p> <p>It is the responsibility of the user to assign personnel to run and/or maintain the machine who are suitable both physically, mentally, and professionally for the tasks and responsibilities involved in each.</p> <p>In particular, for personal and general safety, the machine must absolutely never be operated by people with abnormal reaction times because of their intake of medicines or similar substances, or because of physical defects that slow their movements.</p> <p>It is strongly recommended to make all operators aware of their responsibilities when running the machine. For that purpose, it is also important to collect their recommendations, complaints, and suggestions, as well as all notations on any anomalies that may occur.</p>

				
<p>Indicates actions that must not be taken (prohibited actions).</p>	<p>Indicates actions that must be taken and/or instructions that must be followed.</p>	<p>Do not disassemble</p>	<p>Do not touch</p>	<p>No flames</p>





				
<p>Eye protection must be worn</p>	<p>Protective gloves must be worn</p>	<p>Protective clothing must be worn</p>	<p>Respiratory protection must be worn</p>	<p>Hair net required</p>





Symbols on This Machine

Do not remove the warning labels that are attached to this machine. If a warning label becomes illegible or is removed, contact qualified service personnel for a replacement label.

				
CAUTION: Risk of electric shock	CAUTION: High temperature	CAUTION: Risk of pinching or crushing fingers	CAUTION: Risk of hand injury	

				
CAUTION: Risk of becoming pulled into machine		CAUTION: Risk of becoming caught between parts		Do not operate without guard

				
CAUTION: Risk of damage, falling, or injury due to breakage	No pacemakers	CAUTION: Strong magnetic field	CAUTION: Watch your head	No flames

			
Do not wear scarves/neckties	Do not clean, maintain, or repair	Connect an earth terminal to the ground	USB

Warning Labels

Labels are affixed to the machine to draw attention to dangerous locations.

Front

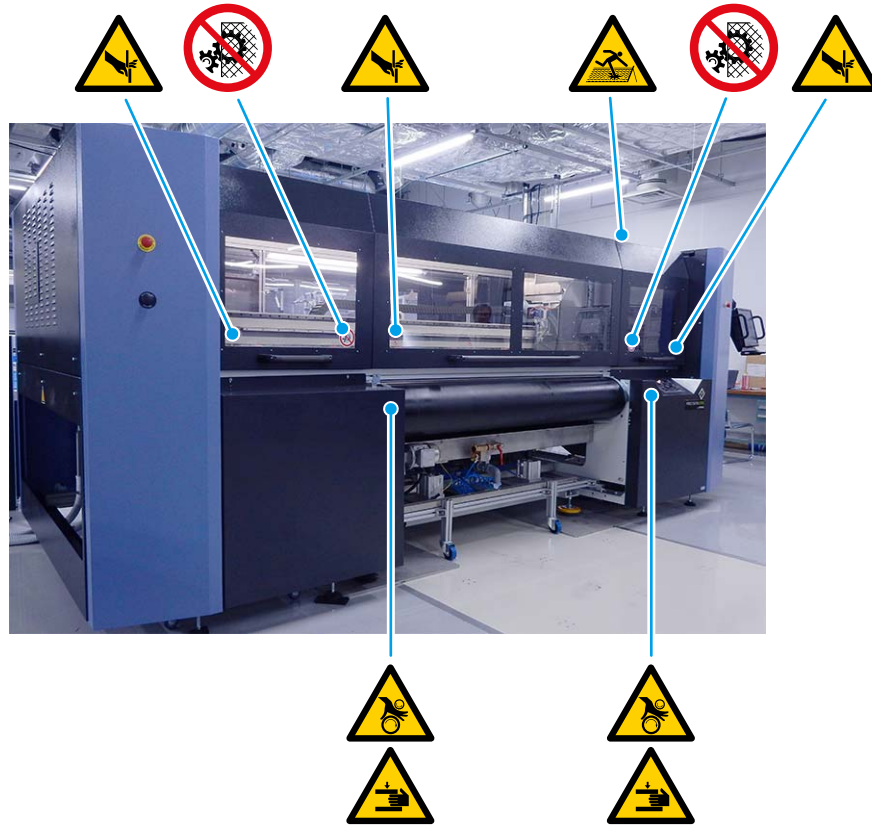

Rear

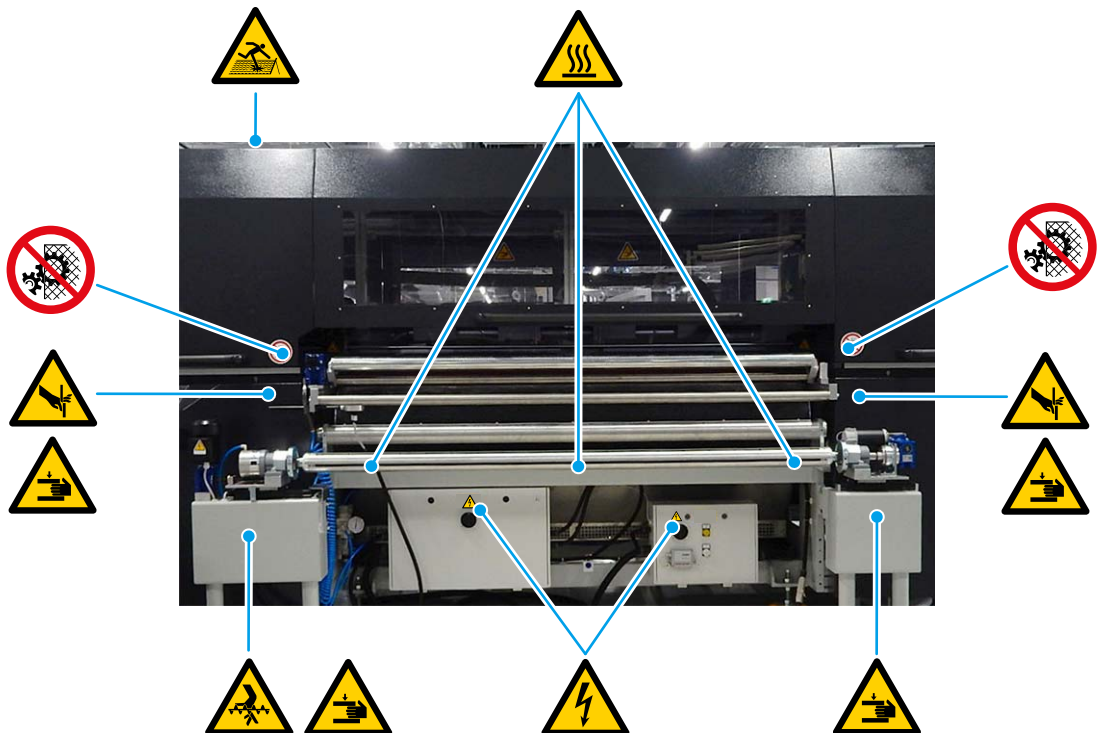

When opening the front protective covers



Print head



When opening the rear protective covers

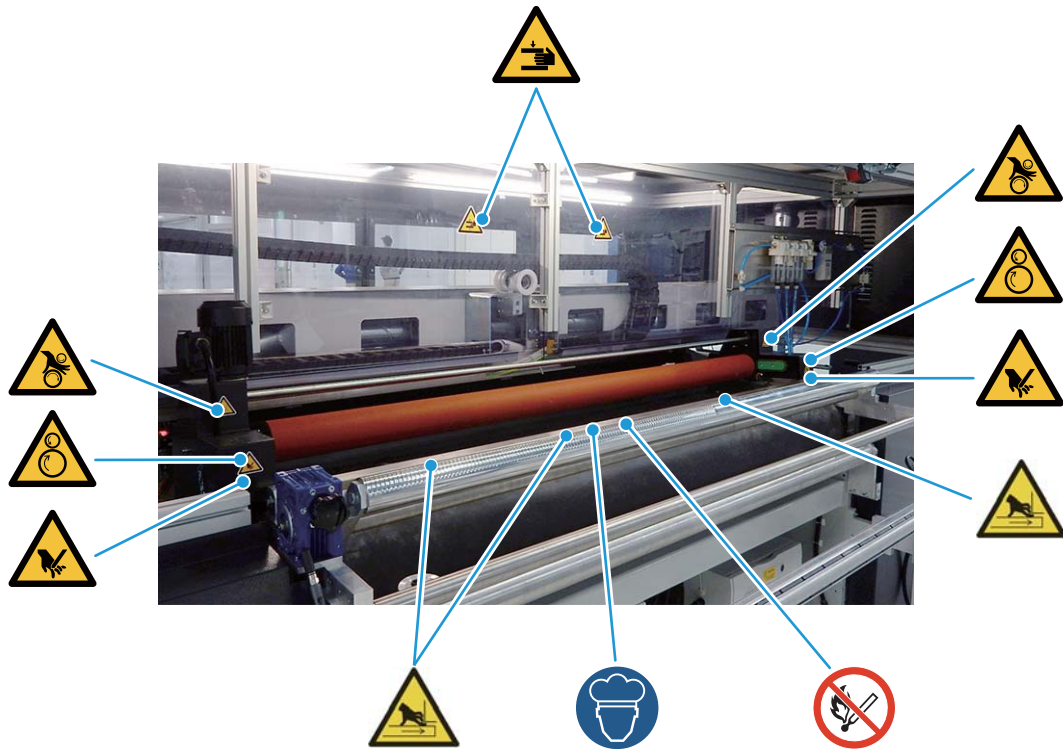

Ink rack (3L)

The ink rack is located on the left side of the machine.



Ink rack (10L)





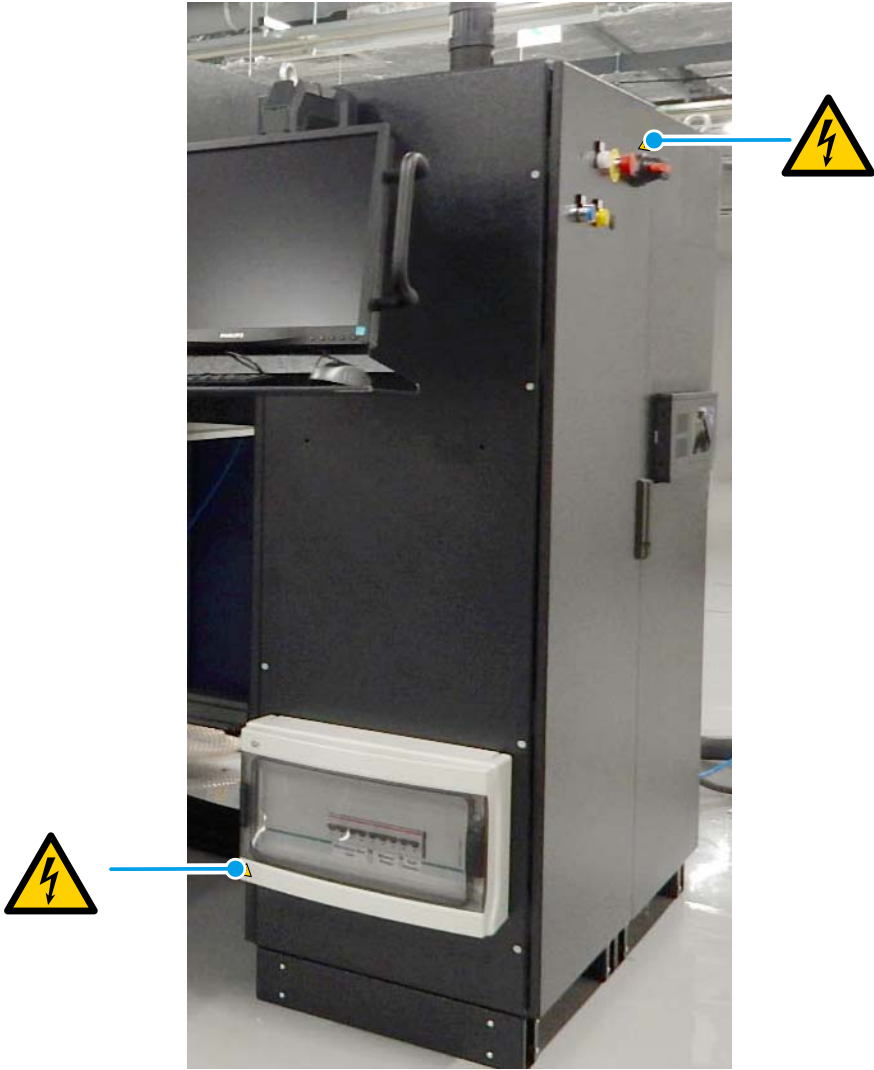



Main electric box













Safety Information











This section provides information that must be observed in order to use this machine safely and prevent injury and/or property damage.



General Precautions

 WARNING	
	Use a power cord that meets the safety standards for the region in which this machine is used.
	Contact qualified service personnel before connecting a new earth terminal.
	<p>Install this machine on a flat, stable surface that is wider than the machine and that can safely support its weight.</p> <p>Contact qualified service personnel for assistance before moving this machine.</p> <p>There is a risk of injury if this machine tips over.</p> <p>There is a risk of electric shock or fire if cables become damaged.</p> <p>Expected performance levels might no longer be guaranteed if changes are made to the condition of this machine.</p>
	<p>Do not use this machine near flames or volatile substances such as alcohol and thinner.</p> <p>Otherwise, there is a risk of electric shock or fire.</p>
	<p>Do not use this machine in environments where flammable gas or explosive gas might be present. In addition, do not use flammable gas sprays in or near this machine.</p> <p>Otherwise, there is a risk of fire.</p>

 CAUTION	
   	<p>Be sure to wear personal protective equipment (gloves, work clothes) when operating this machine. Long hair should be tied back and worn under a hair net.</p> <p>Otherwise, your hands and clothing could become stained with ink, and your fingers and hair could become caught in the machine.</p>
    	<p>Wear eye protection, protective gloves, protective clothing, and respiratory protection when applying or removing glue or removing ink film.</p> <p>Check the Safety Data Sheet (SDS) for the glue, remover, or ink film remover you will actually use for details, and wear the necessary protective gear.</p>

Handling Precautions

 WARNING	
	<p>Immediately stop using this machine if there is smoke, unusual odors or sounds, or any other abnormal conditions. Otherwise, there is a risk of electric shock or fire. If an abnormal condition occurs, immediately turn off the main power, cut off all power supplied to the machine, and contact qualified service personnel for assistance.</p> <p>Do not attempt any repairs yourself. Doing so is extremely dangerous.</p> <p>Do not insert or drop metallic or flammable items into any openings on the machine. Otherwise, there is a risk of electric shock or fire.</p>
	<p>Do not touch any areas inside this machine other than those that are indicated in this manual. Otherwise, there is a risk of electric shock or burns.</p>
	<p>Do not remove any parts other than those that are indicated in this manual, and do not install, disassemble, or modify any parts other than those specified. Otherwise, you could be injured or an accident could occur due to abnormal heat or electric shock.</p>
	<p>Do not deliberately remove or disable safety devices. Doing so leads to the risk of injury, malfunction, and/or damage to the machine.</p>
	<p>Do not operate this machine or the computer while maintenance is being performed. Doing so leads to the risk of your hand or other parts of your body becoming caught in the machine.</p>
 	<p>Keep your hands away from the following moving parts while the machine is operating. Otherwise, there is a risk of your hands, hair, or clothing becoming caught in the machine.</p> <ul style="list-style-type: none"> • Between the fabric guide bar and the fabric • Fabric feeding belt • Pressure roller • Belt cleaning unit chain • Vertically moving parts of the belt cleaning unit, etc.
	<p>Do not operate this machine if you have a pacemaker. The electromagnetic waves that are generated by this machine can affect the operation of pacemakers.</p>
	<p>This machine generates a strong magnetic field. Do not use precision equipment such as watches and mobile telephones nearby. Precision equipment could malfunction or become damaged by the strong magnetic field.</p>





 CAUTION	
	<p>Be careful to avoid pinching your hands and fingers or hitting your head on the corner of the protective covers when opening and closing the protective covers on this machine. Failure to do so could lead to injury.</p>
	<p>The setting and removal of fabric rolls should be performed by two people. When lifting a fabric roll, lift with your legs and not your back. Fabric rolls weigh 30 kg or more. Dropping a fabric roll can lead to injury. Lifting with incorrect posture can lead to injury and/or back pain.</p>







Cautionary Information Regarding Consumables (Ink, Maintenance Liquid) and Waste Ink

Read the Safety Data Sheet (SDS) before handling ink cartridges*, maintenance liquid*, and waste ink.

You can download it at your local Epson Web site.









* These are consumable items (sold separately).

 WARNING	
	<p>If fluid gets on your skin or enters your eyes or mouth, take the measures below.</p> <ul style="list-style-type: none"> • If fluid gets on your skin, rinse immediately with soap and water. • If fluid enters your eyes, rinse immediately with water. Failure to observe this precaution could result in bloodshot eyes or mild inflammation. If problems persist, consult with a physician. • If fluid enters your mouth, consult a physician immediately.
	<p>Do not disassemble or remodel the cartridge. Otherwise, fluid could get in your eyes or come in contact with your skin.</p>
	<p>Keep ink cartridges, maintenance liquid, cleaning liquid, scan spindle grease, waste ink, glue, remover, and ink film remover out of the reach of children.</p>



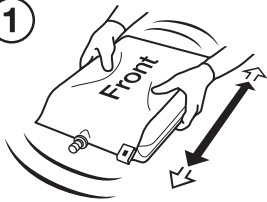
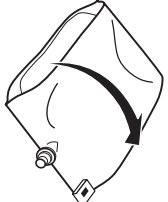
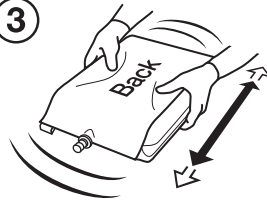





 CAUTION	
    	<p>During maintenance, wear eye protection, protective gloves, protective clothing, and respiratory protection as required.</p>

Handling Precautions for Ink Cartridges

Ink Cartridges (3L)

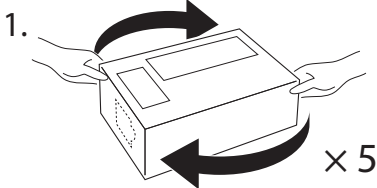
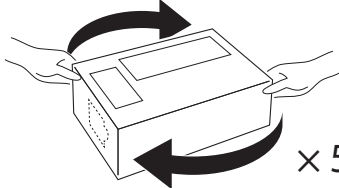
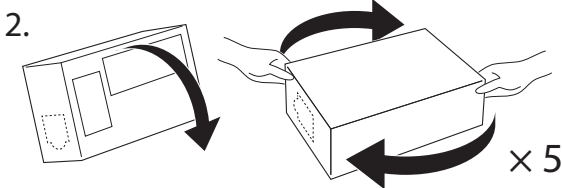
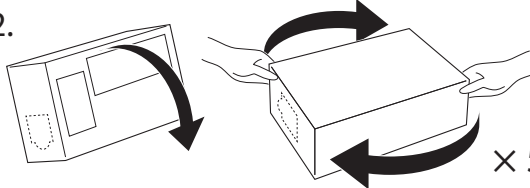
 CAUTION	
	<p>Do not touch the IC chip on the cartridge.</p>
	<p>Store ink cartridges within the indicated temperature range. Do not store them in high or freezing temperatures.</p>
	<p>Do not use reactive ink, acid ink, dispersion ink, and pigment ink at the same time (including ink penetration liquid).</p>
	<p>Before installing, stir the ink as shown below. However, stirring is not needed for ink penetration liquid and cleaning liquid.</p> <div style="display: flex; justify-content: space-around; align-items: center;"> <div style="text-align: center;"> <p>①</p>  </div> <div style="text-align: center;"> <p>②</p>  </div> <div style="text-align: center;"> <p>③</p>  </div> </div>
	<p>Dispose of used cartridge according to local laws and regulations.</p>
	<p>Epson recommends the use of genuine Epson ink cartridge. Epson cannot guarantee the quality or reliability of nongenuine ink.</p> <p>The use of non-genuine ink may cause damage that is not covered by Epson's warranties, and under certain circumstances, may cause erratic printer behavior.</p> <p>For more information about the warranty for this machine, please refer to the Delivery Specifications.</p>
	<p>This machine is designed to stop operating before the ink completely runs out, in order to maintain the quality of the print head. Therefore, a small amount of ink will remain in used ink cartridges. The running cost will vary by usage environment and usage conditions.</p>

Ink Cartridges (10L)

 CAUTION	
	<p>Do not touch the IC chip on the cartridge.</p>
	<p>Store ink cartridges within the indicated temperature range. Do not store them in high or freezing temperatures.</p>
	<p>Do not use reactive ink, acid ink, dispersion ink, and pigment ink at the same time (including ink penetration liquid).</p>
	<p>Before installing, stir ink with the following procedures. However, stirring is not needed for ink penetration liquid and cleaning liquid.</p> <ol style="list-style-type: none"> 1. Put cartridge on flat surface and rotate 5 times. 2. Turn over cartridge and rotate 5 times. <div style="display: flex; justify-content: space-around; align-items: center;"> <div style="text-align: center;">  <p>1.  × 5</p> </div> <div style="text-align: center;">  <p>2.  × 5</p> </div> </div>
	<p>Dispose of used cartridge according to local laws and regulations.</p>
	<p>Epson recommends the use of genuine Epson ink cartridge. Epson cannot guarantee the quality or reliability of nongenuine ink.</p> <p>The use of non-genuine ink may cause damage that is not covered by Epson's warranties, and under certain circumstances, may cause erratic printer behavior.</p> <p>For more information about the warranty for this machine, please refer to the Delivery Specifications.</p>
	<p>This machine is designed to stop operating before the ink completely runs out, in order to maintain the quality of the print head. Therefore, a small amount of ink will remain in used ink cartridges. The running cost will vary by usage environment and usage conditions.</p>

Emergency Stop and Pause

Emergency Stop

In the event of an emergency, press an emergency stop button on the machine. There is a total of five emergency stop buttons on the machine, on the left and right sides of the front and rear sides and one in the main electric panel. The machine comes to an immediate stop when an emergency stop button is pressed. If printing is in progress when the emergency stop button is pressed, printing will not resume from the point where it ended. Execute Set point and then set the job again and resume printing.

Pause

Press the [STOP/PAUSE] button on the machine. There is a total of four [STOP/PAUSE] buttons on the machine, on the left and right sides of the front and rear sides. If a [STOP/PAUSE] button is pressed, printing is paused and the head comes to a stop at either the flushing area or the cleaning station. Press the [Start] button for Leonardo to resume printing.

Standards and Approvals

For Users in Europe

robustelli

CE Dichiarazione di conformità UE EU Declaration of Conformity (DoC)

Nome del fabbricante / Company name:	F.lli. Robustelli S.R.L.
Indirizzo postale / Postal address:	Via Firenze 3
CAP e Città / Postcode and City:	22079 Villa Guardia CO
Telefono / Telephone :	031/483319
Indirizzo Posta elettronica / E-Mail address:	info@fratellirobustelli.com

**Declare that this DoC is issued under the sole responsibility
and belongs to the following product:**

Denominazione modello / Model denomination:	Monna Lisa® EVO TRE
Tipo prodotto / Product Type:	16PC-180
Numero serie / Serial number:	FR-12015B02
Anno di Costruzione / Year of construction:	2018

Oggetto della dichiarazione (Funzione) / Object of the declaration (Function) :
Textile digital printer

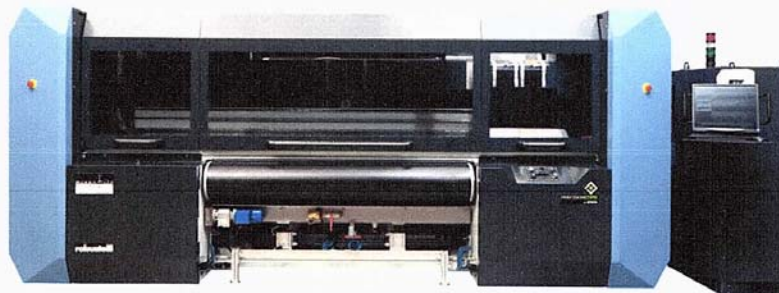

*L'oggetto della dichiarazione di cui sopra è conforme alla pertinente normativa di armonizzazione dell'Unione /
The object of the declaration described above is in conformity with the relevant Union harmonization legislation:*

- **Direttive 2006/42/CE (direttiva Macchine) e 2014/30/UE (direttiva EMC)**
- **Directives 2006/42/CE (Machinery directive) and 2014/30/EU (EMC directive)**

F.LLI ROBUSTELLI S.R.L.

INDUSTRIAL DIGITAL TEXTILE PRINTING SOLUTIONS

Via Firenze, 3 - 22079 Villa Guardia (CO) - Italia
Phone: +39.031.483319 - Fax: +39.031.563121
www.fratellirobustelli.com - E-mail: info@fratellirobustelli.com
Capitale sociale € 90.000,00 i.v. R.E.A. di Como n. 69079
M.N. CO 004192 C.F./P.I. 00221450133 - VAT IT 00221450133

*Soggetto che esercita la direzione ed il coordinamento ai sensi dell'Art. 2497 bis del C.C.: Epson Italia S.p.A.
Società con Socio Unico*



Altre direttive applicabili / Other applicable Directives

Riferimento alle pertinenti norme armonizzate utilizzate /

The following harmonized standards and technical specifications have been applied:

Titolo / Title :	Data di pubblicazione / Date of standard issuing
EN 12100 (Sicurezza del macchinario) Safety of machinery .	2010
EN 60204-1+A1:2009 (Equipaggiamento elettrico delle macchine) Electrical equipment .	2006
EN 13849-1:2015 (Sicurezza dei sistemi di comando) Safety of control systems.	2015
EN 55011 (Disturbi Radio frequenza) Radio Frequency noise .	2016
EN 61000-6-2 (EMC Immunità per ambienti industriali) EMC .	2005

Informazioni supplementari / Additional information:

Test Report n° IEC 60204-1 and EMCTR_172621-0

Firmato a nome e per conto di / Signed for and on behalf of:

Villa Guardia (CO) : 19/03/2017

(Luogo e data del rilascio / Place and date of issue)

Mr. Sandro Robustelli / Managing Director

(Nome, funzione, firma / Name, function, signature)

F.LLI ROBUSTELLI S.R.L.

INDUSTRIAL DIGITAL TEXTILE PRINTING SOLUTIONS

Via Firenze, 3 - 22079 Villa Guardia (CO) - Italia
 Phone: +39.031.483319 - Fax: +39.031.563121
www.fratellirobustelli.com - E-mail: info@fratellirobustelli.com
 Capitale sociale € 90.000,00 i.v. R.E.A. di Como n. 69079
 M.N. CO 004192 C.F. / P.I. 00221450133 - VAT IT 00221450133

*Soggetto che esercita la direzione ed il coordinamento ai sensi dell'Art. 2497 bis del C.C. : Epson Italia S.p.A.
 Società con Socio Unico*

Specifications

This section describes the specifications for the EVO TRE Series.

Basic Specifications

EVO TRE 8

Item	Specifications	Notes
Printhead	Inkjet	8-color
Compatible inks	Reactive ink, dispersion ink, acid ink, Pigment ink, Ink penetration liquid (acid and reactive use)	
Printing resolution	X: Scanning direction Min. 300 dpi to Max. 1,200 dpi Y: Fabric feed direction 600 dpi, 1,200 dpi	
Print speed	See "EVO TRE 8" on page 28.	
Max. printing width	1,800 mm {70,866 in}	
Color number	8-color	
Ink pack	1 color/1 pack	
Ink pack capacity	3 liters {183 in ³ }	
Printer operating environment	Temperature: 20 to 30 °C {68 to 86 °F} Humidity: 35 to 85 % RH (no condensation)	
Recommended printing environment	Temperature: 22 to 28 °C {71.6 to 82.4 °F} Humidity: 35 to 80 % RH (no condensation)	
Printer storage environment	Store the printer filled with ink. Temperature: 0 to 35 °C {32 to 95 °F} 1 month Must not be any condensation.	
Device dimensions	Printer: 4,654 (W) x 2,386 (D) x 1,952 (H) mm {183 x 94 x 77 in} Main electric box: 576 (W) x 1,200 (D) x 2,025 (H) mm {23 x 47 x 80 in}	Not including feeding device and drying winder. Height includes the adjusters and tower lamp.
Equipment weight	Printer: Approx. 3,521 kg {7,762 lb} Main electric box: Approx. 328 kg {723 lb} Ink rack: The ink rack is contained in the printer.	

EVO TRE 16

Item	Specifications	Notes
Printhead	Inkjet	8-color
Compatible inks	Reactive ink, dispersion ink, acid ink, Pigment ink, Ink penetration liquid (acid and reactive use)	
Printing resolution	X: Scanning direction Min. 300 dpi to Max. 1,200 dpi Y: Fabric feed direction 600 dpi, 1,200 dpi	
Print speed	See "EVO TRE 16" on page 29.	
Max. printing width	1,800 mm {70,866 in}, 2,200 mm {86,614 in}, 3,200 mm {125,984 in}	
Color number	8-color	
Ink pack	1 color/1 pack	
Ink pack capacity	3 liters {183 in ³ } or 10 liters {610 in ³ }	
Printer operating environment	Temperature: 20 to 30 °C {68 to 86°F} Humidity: 35 to 80 % RH (no condensation)	
Recommended printing environment	Temperature: 22 to 28 °C {71.6 to 82.4 °F} Humidity: 35 to 80 % RH (no condensation)	
Printer storage environment	Store the printer filled with ink. Temperature: 0 to 40 °C {32 to 104 °F} 1 month Must not be any condensation.	
Device dimensions	Printer: 4,660 (W) x 2,390 (D) x 1,940 (H) mm {183 x 94 x 76 in} Main electric box: 620 (W) x 1,220 (D) x 2,070 (H) mm {24 x 48x 81 in} Ink rack (10L): 1,240 (W) x 1,300 (D) x 1,220 (H) mm {49 x 51 x 48 in}	Notincluding feeding device and drying winder. Height includes the adjusters and tower lamp.
Equipment weight	Printer: Approx. 3,500 kg {7,716 lb} Main electric box: Approx. 330 kg {728 lb} Ink rack (10L): Approx. 380 kg {838 lb}	

EVO TRE 32

Item	Specifications	Notes
Printhead	Inkjet	8-color
Compatible inks	Reactive ink, dispersion ink, acid ink, Pigment ink	
Printing resolution	X: Scanning direction Min. 300 dpi to Max. 1,200 dpi Y: Fabric feed direction 600 dpi, 1,200 dpi	
Print speed	See "EVO TRE 32" on page 31.	
Max. printing width	1,800 mm {70,866 in}	
Color number	8-color	
Ink pack	1 color/1 pack	
Ink pack capacity	3 liters {183 in ³ } or 10 liters {610 in ³ }	
Printer operating environment	Temperature: 20 to 30°C {68 to 86°F} Humidity: 35 to 80 % RH (no condensation)	
Recommended printing environment	Temperature: 22 to 28°C {71.6 to 82.4 °F} Humidity: 35 to 80 % RH (no condensation)	
Printer storage environment	Store the printer filled with ink. Do not turn off the power for dry air when storing the printer. Temperature: 0 to 40°C {32 to 104 °F} 1 month Must not be any condensation.	
Device dimensions	Printer: 4,610 (W) x 2,040 (D) x 2,070 (H) mm {181 x 80 x 81 in} Main electric box: 1,800 (W) x 700 (D) x 2,350 (H) mm {28 x 71x 93 in} Ink rack (10L): 1,240 (W) x 1,300 (D) x 1,220 (H) mm {49 x 51 x 48 in}	Notincluding feeding device and drying winder. Height includes the adjusters and tower lamp.
Equipment weight	Printer: Approx. 3,700 kg {8,157 lb} Main electric box: Approx. 570 kg {1,257 lb} Ink rack (10L): Approx. 380 kg {838 lb}	

Resolution/Number of Passes and Print Speed

EVO TRE 8

* Prerequisites: Bidirectional printing, 1,500 mm printing width

Print speed differs depending on the images, firmware, PC operating status and print settings.

Resolution		Number of passes	Print speed * (m ² /h)
Scan direction [dpi]	Belt direction [dpi]		
300	600	1 pass	234
	600	2 passes	130
	600	3 passes	87
	600	4 passes	64
	600	4+ passes	55
	1,200	2 passes	125
	1,200	4 passes	67
	1,200	6 passes	44
	1,200	8 passes	27
600	600	1 pass	151
	600	2 passes	125
	600	3 passes	90
	600	4 passes	67
	600	4+ passes	53
	1,200	2 passes	79
	1,200	4 passes	65
	1,200	6 passes	45
	1,200	8 passes	26

Resolution		Number of passes	Print speed * (m ² /h)
Scan direction [dpi]	Belt direction [dpi]		
900	600	1 pass	108
	600	2 passes	99
	600	3 passes	86
	600	4 passes	67
	600	4+ passes	42
	1,200	2 passes	56
	1,200	4 passes	50
	1,200	6 passes	43
	1,200	8 passes	21
1,200	600	1 pass	83
	600	2 passes	79
	600	3 passes	73
	600	4 passes	65
	600	4+ passes	33
	1,200	2 passes	42
	1,200	4 passes	40
	1,200	6 passes	36
	1,200	8 passes	17

EVO TRE 16

* Prerequisites: Bidirectional printing, 1,500 mm printing width

Print speed differs depending on the images, firmware, PC operating status and print settings.

Resolution		Number of passes	Print speed * (m ² /h)
Scan direction [dpi]	Belt direction [dpi]		
300	600	1 pass	404
	600	2 passes	236
	600	3 passes	159
	1,200	2 passes	215
	1,200	4 passes	120
	1,200	6 passes	80

Resolution		Number of passes	Print speed * (m ² /h)
Scan direction [dpi]	Belt direction [dpi]		
600	600	1 pass	270
	600	2 passes	221
	600	3 passes	160
	600	4 passes	120
	600	4+ passes	103
	1,200	2 passes	135
	1,200	4 passes	111
	1,200	6 passes	81
	1,200	8+ passes	52
900	600	1 pass	182
	600	2 passes	171
	600	3 passes	147
	600	4 passes	120
	600	4+ passes	79
	1,200	2 passes	90
	1,200	4 passes	87
	1,200	6 passes	74
	1,200	8+ passes	40
1,200	600	1 pass	142
	600	2 passes	135
	600	3 passes	126
	600	4 passes	126
	600	4+ passes	63
	1,200	2 passes	71
	1,200	4 passes	69
	1,200	6 passes	63
	1,200	8+ passes	32

EVO TRE 32

* Prerequisites: Bidirectional printing, 1,500 mm printing width

Print speed differs depending on the images, firmware, PC operating status and print settings.

Resolution		Number of passes	Print speed * (m ² /h)
Scan direction [dpi]	Belt direction [dpi]		
300	600	1 pass	692
	600	2 passes	425
	600	3 passes	299
	1,200	2 passes	403
	1,200	4 passes	220
	1,200	6 passes	150
600	600	1 pass	472
	600	2 passes	402
	600	3 passes	289
	600	4 passes	217
	600	4+ passes	187
	1,200	2 passes	238
	1,200	4 passes	198
	1,200	6 passes	145
	1,200	8 passes	93
900	600	1 pass	329
	600	2 passes	312
	600	3 passes	261
	600	4 passes	217
	600	4+ passes	145
	1,200	2 passes	162
	1,200	4 passes	153
	1,200	6 passes	132
	1,200	8+ passes	72

Resolution		Number of passes	Print speed * (m ² /h)
Scan direction [dpi]	Belt direction [dpi]		
1,200	600	1 pass	252
	600	2 passes	239
	600	3 passes	222
	600	4 passes	222
	600	4+ passes	114
	1,200	2 passes	127
	1,200	4 passes	123
	1,200	6 passes	110
	1,200	8+ passes	57

Printing Width

Item		Specifications
Possible printing area	Scan direction (x)	300 to 1,800 mm {11.8 to 70.9 in}
Margin specifications		No margin
Printing width settings input units		0.1 mm {0.0039 in}

Elevation

1,000 m {3,281 ft} or less

Power

EVO TRE 8

Item	Specifications	Notes
Voltage	400 V \pm 10 %, 3-phase + Neutral + Earth	
Frequency	50 / 60 Hz \pm 3 %	
Power consumption	20 KVA	
Leakage current	300 mA or less	
Factory facilities Connected/Wired	Type: Terminal block connection Connecting part model: CBD 16 (Manufacturer. by Cabur) Compatible crimped terminals (reference): Ferrule type WP160/22 Wiring specifications (recommended): 600 V pressure resistance (UL1063 equivalent) Wire size of AWG12 or larger	

Factory facilities

Item	Specifications	Notes
Electrical power	See "EVO TRE 8" on page 34.	
Pressurized air	Connector: Connect with a Φ 8 mm (ext. diam.) hose Pressure: Min. 0.6 MPa (6 bar) Flow rate: 400 Liter/hr	Required for raising/lowering the cleaning tank, ink pressure, etc.
Water	Connector: 3/4 gas Pressure: Max. 0.5 MPa (5 bar) Flow rate: Max. 100 Liter/hr {6,102 in ³ /h}	Required for belt cleaning.
Wastewater	Connect with a Φ 40 mm (ext. diam.) pipe	Required for wastewater for belt cleaning. Users are requested to dispose of wastewater according to local laws and regulations.
Waste liquid	Flushing area Outer diameter of ink discharge outlet: Φ 20 mm Applicable inner tube diameter: Φ 19 mm	Waste ink is discharged from the flushing area and cleaning station, and therefore it is necessary to provide a route for waste liquid in the factory's drainage system. Users are requested to dispose of waste ink according to local laws and regulations.
	Cleaning station Outer diameter of ink discharge outlet: Φ 40 mm Applicable inner tube diameter: Φ 38 to 39 mm	
Exhaust	Connector: Φ 125 mm Flow rate: 1,200 m ³ /hr {73,228,493 in ³ /h}	Required for mist exhaust in the machine. If a 1,200 m ³ /h exhaust system is not available, please provide a mist exhaust fan.

Item	Specifications	Notes
Network	A communication speed of 100BASE-TX or more is recommended	Please provide a network environment to which a PC can be connected.

EVO TRE 16

Item	Specifications	Notes
Voltage	400 V \pm 10 %, 3-phase + Neutral + Earth	
Frequency	50 / 60 Hz \pm 3 %	
Power consumption	20 KVA	
Leakage current	300 mA or less	
Factory facilities Connected/Wired	Type: Terminal block connection Connecting part model: CBD 16 (Manufacturer. by Cabur) Compatible crimped terminals (AWG12 Reference for wiring selection): 3-phase + Neutral: AI4-12 GY (PHOENIX CONTACT) Earth: R5.5-5 (J.S.T.) Wiring specifications (recommended): 600 V pressure resistance (UL1063 equivalent) Wire size of AWG12 or larger	

Factory facilities

Item	Specifications	Notes
Electrical power	See "EVO TRE 16" on page 35.	
Pressurized air	Connector: Connect with a Φ 8 mm X 6 (ext. diam.) hose Pressure: Min. 0.6 MPa (6 bar) Flow rate: 1,500 Liter/hr	Required for raising/lowering the cleaning tank, ink pressure, etc.
Water	Connector: 3/4 gas Pressure: 0.4 Mpa (4 bar) - 0.6 MPa (6 bar) Flow rate: Max. 100 Liter/hr {6,102 in ³ /h}	Required for belt cleaning.
Wastewater	Connector: Φ 100 mm Connect with a Φ 40 mm (ext. diam.) pipe	Required for wastewater for belt cleaning. Users are requested to dispose of wastewater according to local laws and regulations.

Item	Specifications	Notes
Waste liquid	Flushing area Outer diameter of ink discharge outlet: $\Phi 20$ mm Applicable inner tube diameter: $\Phi 19$ mm	Waste ink is discharged from the flushing area and cleaning station, and therefore it is necessary to provide a route for waste liquid in the factory's drainage system.
	Cleaning station Outer diameter of ink discharge outlet: $\Phi 40$ mm Applicable inner tube diameter: $\Phi 38$ to 39 mm	Users are requested to dispose of waste ink according to local laws and regulations.
Exhaust	Connector: $\Phi 125$ mm Pipe length: 10 m Flow rate: $1,200$ m ³ /hr { $73,228,493$ in ³ /h} (A tube diameter of $\Phi 125$ mm corresponds to a wind speed of 27.1 m/sec.) (A tube diameter of $\Phi 200$ mm corresponds to a wind speed of 10.6 m/sec.)	Required for mist exhaust in the machine. If a $1,200$ m ³ /h exhaust system is not available, please provide a mist exhaust fan.
Network	A communication speed of 100BASE-TX or more is recommended	Please provide a network environment to which a PC can be connected.

EVO TRE 32

Item	Specifications	Notes
Voltage	400 V \pm 10%, 3-phase + Neutral + Earth	
Frequency	$50/60$ Hz \pm 3%	
Power consumption	20 KVA	
Leakage current	300 mA or less	
Factory facilities Connected/Wired	Type: Terminal block connection Connecting part model: CBD 16 (Manufacturer. by Cabur) Compatible crimped terminals (AWG12 Reference for wiring selection): 3-phase + Neutral: AI4-12 GY (PHOENIX CONTACT) Earth: R5.5-5 (J.S.T.) Wiring specifications (recommended): 600 V pressure resistance (UL1063 equivalent) Wire size of AWG12 or larger	

Factory facilities

Item	Specifications	Notes
Electrical power	See "EVO TRE 32" on page 36.	
Pressurized air	Connector: Connect with a $\Phi 12$ mm (ext. diam.) hose Pressure: 0.6 MPa (6 bar) Flow rate: 5,000 Liter/hr	Required for raising/lowering the cleaning tank, ink pressure, etc.
Water	Connector: 3/4 gas Pressure: 0.4 Mpa (4 bar) - 0.6 MPa (6 bar) Flow rate: Max 100 Liter/hr {6,102 in ³ /h}	Required for belt cleaning.
Wastewater	Connector: $\Phi 100$ mm Connect with a $\Phi 48$ mm (ext. diam.) pipe (Applicable pipe diameter: 40 A)	Required for wastewater for belt cleaning. Users are requested to dispose of wastewater according to local laws and regulations.
Waste liquid	Flushing area Outer diameter of ink discharge outlet: $\Phi 14$ mm Applicable inner tube diameter: $\Phi 12$ mm	Waste ink is discharged from the flushing area and cleaning station, and therefore it is necessary to provide a route for waste liquid in the factory's drainage system.
	Cleaning station Outer diameter of ink discharge outlet: $\Phi 29$ mm Applicable inner tube diameter: $\Phi 27$ to 28 mm	Users are requested to dispose of waste ink according to local laws and regulations. Provide either one or two routes for waste liquid, depending on the usage environment.
Exhaust	Connector: $\Phi 125$ mm Pipe length: 10 m Flow rate: 1,200 m ³ /hr {73,228,493 in ³ /h} (A tube diameter of $\Phi 125$ mm corresponds to a wind speed of 27.1 m/sec.) (A tube diameter of $\Phi 200$ mm corresponds to a wind speed of 10.6 m/sec.)	Required for mist exhaust in the machine. If connection with factory exhaust is not possible, please provide a mist exhaust fan.
Network	A communication speed of 100BASE-TX or more is recommended	Please provide a network environment to which a PC can be connected.

Supported Ink

The supported inks are subject to change without notice. Check with the distributor where the machine was purchased for the latest information.

3L

Ink Type	Color Name	Color Code	Product No.
Acid	Black	BK	C13T661111 C13T66111A
	Cyan	C	C13T661211
	Magenta	M	C13T661310
	Yellow	Y	C13T661412
	Light Magenta	LM	C13T661610
	Grey	GY	C13T661711 C13T66171A
	Red	R	C13T661811 C13T66181A
	Blue	BL	C13T661910
	Cobalt	CO	C13T661911 C13T66191A
	Orange	OR	C13T661A10
	Orange - F	OR-F	C13T661A11 C13T661A1A
	Rubine	RB	C13T661C10 C13T661C1A
	Fluorescent Flavine	FL	C13T661D10 C13T854D00
	Fluorescent Pink	FP	C13T661E10 C13T854E00
	Vermilion	VE	C13T661H10

Ink Type	Color Name	Color Code	Product No.
Reactive (RE-N)	Black	BK	C13T662111 C13T66211A
	Cyan	C	C13T662210 C13T66221A
	Magenta	M	C13T662310 C13T66231A
	Yellow	Y	C13T662410 C13T66241A
	Light Magenta	LM	C13T662610
	Grey	GY	C13T662710 C13T66271A
	Red	R	C13T662810 C13T66281A
	Blue	BL	C13T662910 C13T66291A
	Orange	OR	C13T662A10 C13T662A1A
	Crimson	CR	C13T662B10 C13T662B1A
	Grey (GOTS) ^{*1}	GY-G	C13T662C10 C13T662C1A
Disperse	Black	BK	C13T663111
	Cyan	C	C13T663210
	Magenta	M	C13T663310
	Yellow	Y	C13T663410
	Grey	GY	C13T663711
	Red	R	C13T663810
	Blue	BL	C13T663910
	Orange	OR	C13T663A10

Ink Type	Color Name	Color Code	Product No.
Pigment	Black	BK	C13T930111 C13T93011A
	Cyan	C	C13T930211 C13T93021A
	Magenta	M	C13T930311 C13T93031A
	Yellow	Y	C13T930411 C13T93041A
	Yellow-C	Y	C13T93041B
	Grey	GY	C13T930711 C13T93071A
	Red	R	C13T930811 C13T93081A
	Green	GR	C13T930911 C13T93091A
	Orange	OR	C13T930A11 C13T930A1A
Others	Ink Penetration Liquid (Acid ink, reactive ink) ^{*2}	AC	C13T661P10
	Ink Penetration Liquid (Disperse ink) ^{*2}	AC	C13T51MA10

*1 GOTS: Global Organic Textile Standard

*2 Do not use the color (column) next to Across in the same head. The discharge of Across may become unstable.
For details, refer to "Colour" in the Leonardo Reference Guide, or inquire with qualified service personnel.

10L

Ink Type	Color Name	Color Code	Product No.
Acid	Black	BK	C13T41X110 C13T41X11A
	Cyan	C	C13T41X210
	Magenta	M	C13T41X310
	Yellow	Y	C13T41X410
	Grey	GY	C13T41X510 C13T41X51A
	Red	R	C13T41X610 C13T41X61A
	Blue	BL	C13T41X710
	Cobalt	CO	C13T41X810 C13T41X81A
	Orange	OR	C13T41X910
	Orange - F	OR-F	C13T41XA10 C13T41XA1A
	Rubine	RB	C13T41XB10 C13T41XB1A
	Navy Blue	NB	C13T41XC10
	Brown	BR	C13T41XD10
	Fluorescent Pink	FP	C13T41XE10
	Fluorescent Flavine	FL	C13T41XF10
	Vermilion	VE	C13T49QH10

Ink Type	Color Name	Color Code	Product No.
Reactive (RE-N)	Black	BK	C13T41Y110 C13T41Y11A
	Cyan	C	C13T41Y210 C13T41Y21A
	Magenta	M	C13T41Y310 C13T41Y31A
	Yellow	Y	C13T41Y410 C13T41Y41A
	Grey	GY	C13T41Y510 C13T41Y51A
	Red	R	C13T41Y610 C13T41Y61A
	Blue	BL	C13T41Y710 C13T41Y71A
	Orange	OR	C13T41Y810 C13T41Y81A
	Navy Blue	NB	C13T41Y910
	Brown	BR	C13T41YA10
	Crimson	CR	C13T41YB10 C13T41YB1A
	Grey (GOTS)* ¹	GY-G	C13T41YC10 C13T41YC1A
Reactive (RE-C)	Black	BK	C13T52G110
	Cyan	C	C13T52G210
	Magenta	M	C13T52G310
	Yellow	Y	C13T52G410
	Grey	GY	C13T52G510
	Red	R	C13T52G610
	Blue	BL	C13T52G710
	Orange	OR	C13T52G810
	Crimson	CR	C13T52GB10

Ink Type	Color Name	Color Code	Product No.
Reactive (RE-E)	Black	BK	C13T52U110
	Cyan	C	C13T52U210
	Magenta	M	C13T52U310
	Yellow	Y	C13T52U410
	Grey	GY	C13T52U510
	Red	R	C13T52U610
	Blue	BL	C13T52U710
	Orange	OR	C13T52U810
Disperse	Black	BK	C13T42A110
	Cyan	C	C13T42A210
	Magenta	M	C13T42A310
	Yellow	Y	C13T42A410
	Grey	GY	C13T42A510
	Red	R	C13T42A610
	Blue	BL	C13T42A710
	Orange	OR	C13T42A810
Pigment	Black	BK	C13T42B110 C13T42B11A
	Cyan	C	C13T42B210 C13T42B21A
	Magenta	M	C13T42B310 C13T42B31A
	Yellow	Y	C13T42B410 C13T42B41A
	Yellow-C	Y	C13T42B41B
	Grey	GY	C13T42B510 C13T42B51A
	Red	R	C13T42B610 C13T42B61A
	Green	GR	C13T42B710 C13T42B71A
	Orange	OR	C13T42B810 C13T42B81A
Others	Ink Penetration Liquid (Acid ink, reactive ink)* ²	AC	C13T41XG10 C13T49QG10
	Ink Penetration Liquid (Disperse ink)* ²	AC	C13T42A910 C13T49SA10

*1 GOTS: Global Organic Textile Standard

*2 Do not use the color (column) next to Across in the same head. The discharge of Across may become unstable.
For details, refer to "Colour" in the Leonardo Reference Guide, or inquire with qualified service personnel.

Ink Cartridges

Ink Cartridges (3L)

Item	Specifications
Ink Type	See "3L" on page 38 .
External dimensions	Width (W): 180 mm {7.1 in} Length (D): 370 mm {14.6 in} Height (H): 70 mm {2.8 in}
Weight	Approx. 3.3 kg {7.3 lb}
Ink color	See "3L" on page 38 .
Transport and storage environment	(1) Temperature: 10 to 35°C {50 to 95 °F} (recommended warranty temperature) For long-term storage of reactive ink cartridges, avoid direct sunlight and keep the cartridges in an indoor environment (recommended: cool, dark place) at an ambient temperature of 30°C {86 °F} or lower. (2) Relative humidity: 35 to 85 % (no condensation)
Orientation during transport and storage	During transport and storage, ink cartridges should be kept with the largest surface facing up. Keep the upward arrow symbol on the box pointing upward.
Stack height during transport and storage	12 cartridges high

Ink Cartridges (10L)

Item	Specifications
Ink Type	See "10L" on page 41 .
External dimensions	Width (W): 158 mm {6.2 in} Length (D): 389 mm {15.3 in} Height (H): 269 mm {10.6 in}
Weight	Approx. 11 kg {388 lb}
Ink color	See "10L" on page 41 .
Operating environment conditions with ink cartridges installed	(1) Temperature: 20 to 30 °C {68 to 86 °F} (2) Relative humidity: 35 to 85 % (no condensation) (3) The ink in a cartridge that has been left in a low temperature environment will freeze at a temperature of -10 °C {14 °F} or less. If ink is frozen, thaw it at room temperature and then use the ink after it is within the operating temperature range. Reference: In a 25 °C {77 °F} environment it takes approximately 34 hours for frozen ink to warm from -10 to 20 °C {14 to 68 °F}.

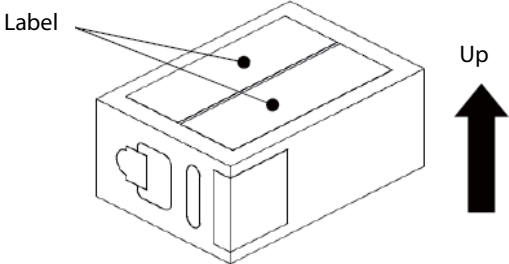
Item	Specifications
Warranty period with ink cartridges installed	(1) Temperature/warranty period without I/C installed: -20 to 60 °C {-4 to 140 °F}/ Max. 5 days -20 to 40 °C {-4 to 104 °F}/ Max. 1 month With I/C installed: -20 to 40 °C {-4 to 104 °F}/ Max. 1 month (2) Relative humidity: 35 to 85 % (no condensation)
Transport and storage environment	(1) Temperature: 10 to 35 °C {50 to 95 °F} (recommended warranty temperature) (2) Relative humidity: 35 to 85 % (no condensation)
Recommended lifetime	Indicated on ink cartridge labels
Orientation during transport and storage	During transport and storage, ink cartridges should be oriented as shown below with the largest surface facing up. <div style="text-align: center;">  </div>
Stack height during transport and storage	7 cartridges high

* The expiration date is indicated on the ink cartridge box.

Consumables

Consumables (3L)

Product Name	Model	Use
Clean StickB	C13S090011	Cap and wiper cleaning
Head Cleaning Cloth A	C13S210050	Head cleaning
Maintenance Liquid	C13T42X000	Wetted parts cleaning
Cleaning Liquid	C13T661N10	For cleaning before initial charging Use it after the ink replacement

Consumables (10L)

Product Name	Model	Use
Clean StickB	C13S090011	Cap and wiper cleaning
Head Cleaning Cloth A	C13S210050	Head cleaning
Maintenance Liquid	C13T42X000	Wetted parts cleaning
Cleaning Liquid	C13T41X010	For cleaning before initial charging Use it after the ink replacement

Name and Function of Each Part

This section describes the name and function of each part.

Name of Major Parts

This section describes the name and function of major parts.

Front

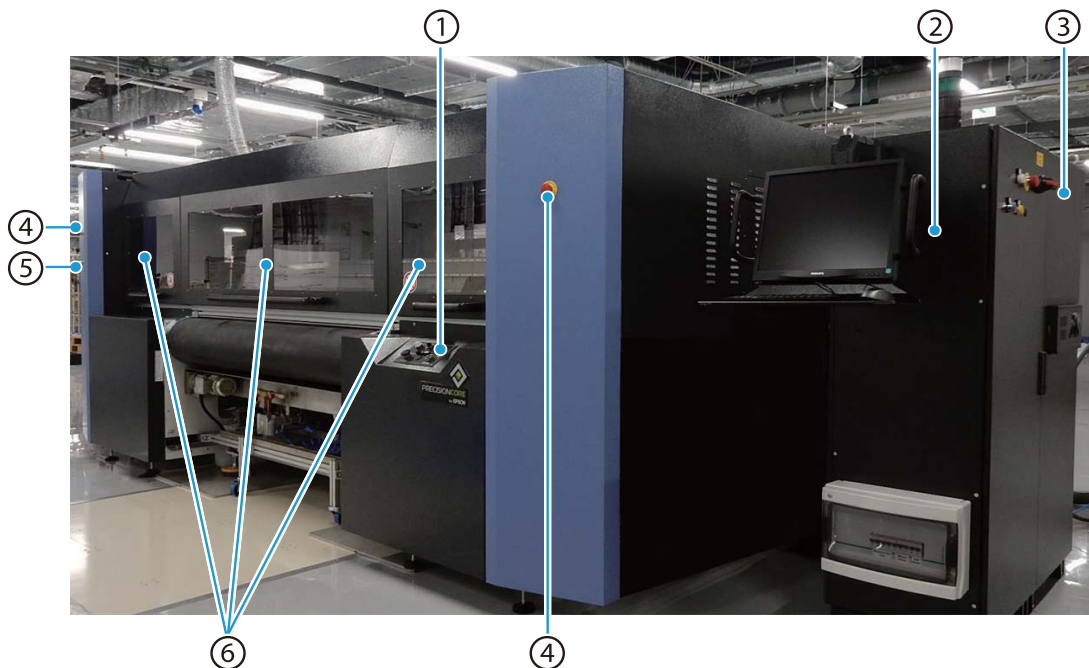

No.	Name	Description
1	Front panel	Location of the operating panel for performing operations on the front of the machine.
2	Control PC	Used to control Leonardo (Application for printer control) from the main unit.
3	Main electric box	Houses the power supply unit and the control PC.
4	Emergency stop button	Stops operation of this machine immediately. Installed at four positions around the printer and one on the main electric box.
5	Pause button	Printing is paused and the print head stops in the flushing area or the cleaning station area. Installed at a total of four positions on the front panel and rear panel.
6	Front Protection Covers	These are movable covers. Open these covers to clean and perform maintenance on the belt, caps & wipers, scan spindle, and flushing plate.

Rear

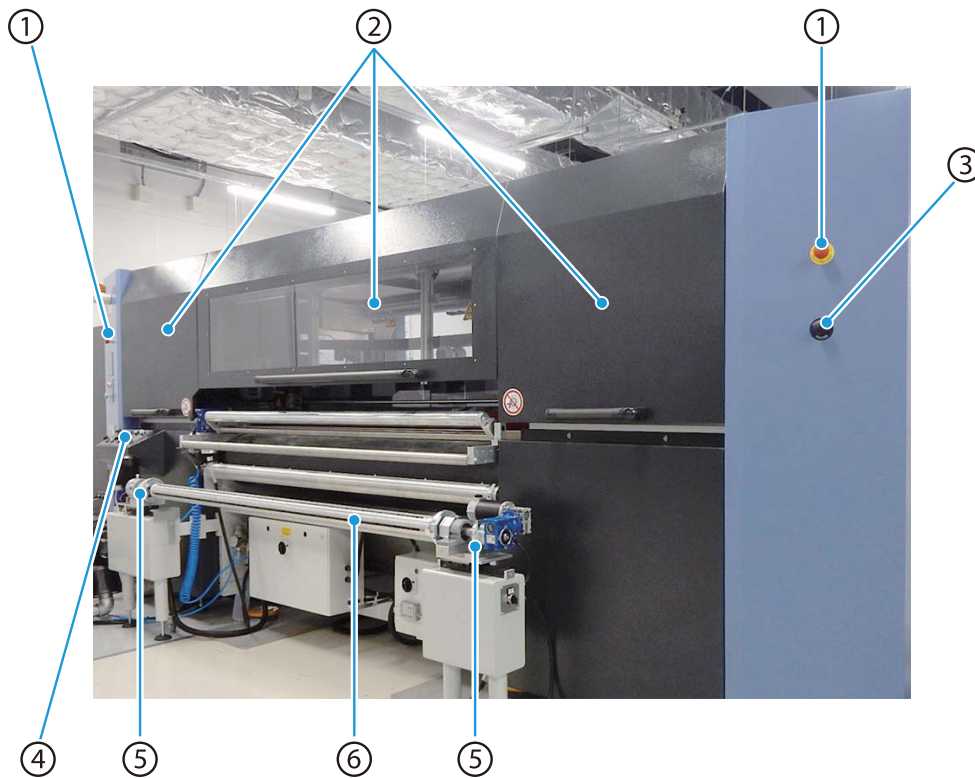

No.	Name	Description
1	Emergency stop button	Stops operation of this machine immediately. Installed at four positions around the printer and one on the main electric box.
2	Rear Protection Covers	These are movable covers. Open these covers to perform maintenance.
3	Pause button	Printing is paused and the print head stops in the flushing area or the cleaning station area. Installed at a total of four positions on the front panel and rear panel.
4	Rear panel	Location of the operating panel for performing operations on the rear of the machine.
5	Feeding unit	The fabric roll is installed here, and the unit feeds the fabric into the machine. Installed on the right and left sides.
6	Fabric spindle	The spindle to attach the fabric. The fabric is attached to this spindle and set to the feeding unit.

Name of Each Part

This section describes the name and function of each part including major parts.

Front

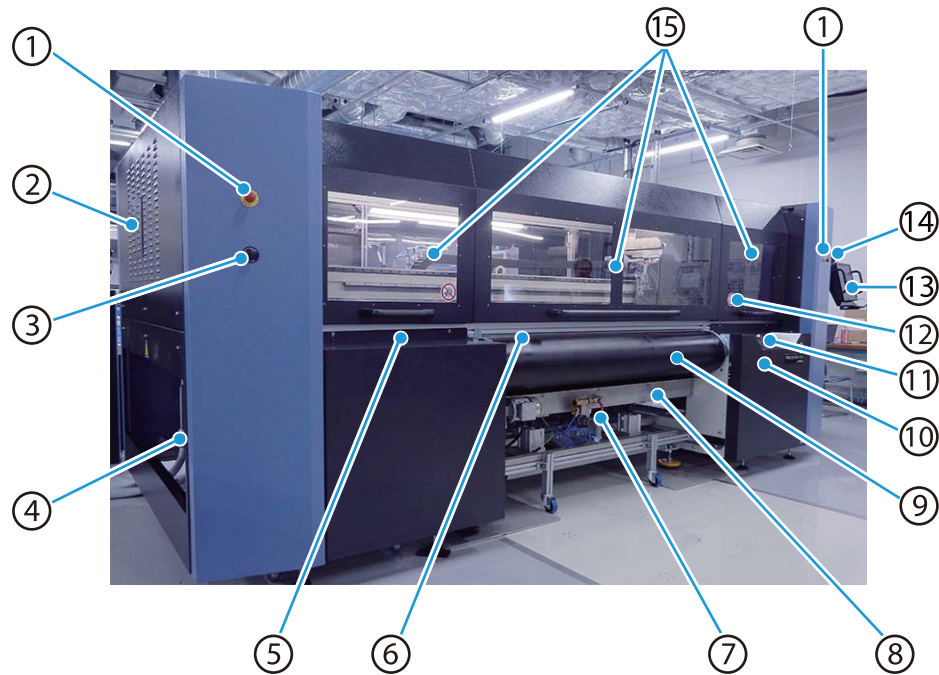

No.	Name	Description
1	Emergency stop button	Stops operation of this machine immediately.
2	Maintenance window for mist filter	Use this maintenance window to clean/replace the mist filter.
3	Pause button	Printing is paused and the print head stops in the flushing area or the cleaning station area.
4	Ink tank housing	This housing contains the sub-tank rack.
5	Flushing area	This contains the flushing plate, and the print head performs flushing here.
6	Fabric peeling prevention bar	This bar prevents the peeled part of the fabric from floating up when winding the printed fabric in the dryer. Adjust the height of the bar whenever changing the fabric type or thickness. For more information, refer to "Adjusting the Fabric Peeling Prevention Bar" on page 70. If you would like to install a fabric peeling prevention bar, contact qualified service personnel.
7	Water supply valve on the belt cleaning unit	This is the valve on the belt cleaning unit that supplies water to the unit.
8	Belt cleaning unit	This unit contains the belt cleaning tank for cleaning ink and other foreign material adhering to the belt.
9	Belt	This belt feeds fabric attached to it.

No.	Name	Description
10	Cleaning station area	Caps and wipers are located at the top, for performing cleaning and replacement. For models with waste ink tanks, a waste ink tank is installed at the bottom of the cleaning station.
11	Front panel	Location of the operating panel for performing operations on the front of the machine.
12	Print Head	Equipped with the print head used for printing on fabric.
13	Control PC	Used to control Leonardo from the main unit.
14	Main electric box	Supplies power and houses the control PC.
15	Front Protection Covers	These are movable covers. Open these covers to clean and perform maintenance on the belt, caps & wipers, scan spindle, and flushing plate.

Front (When opening the front protective covers)

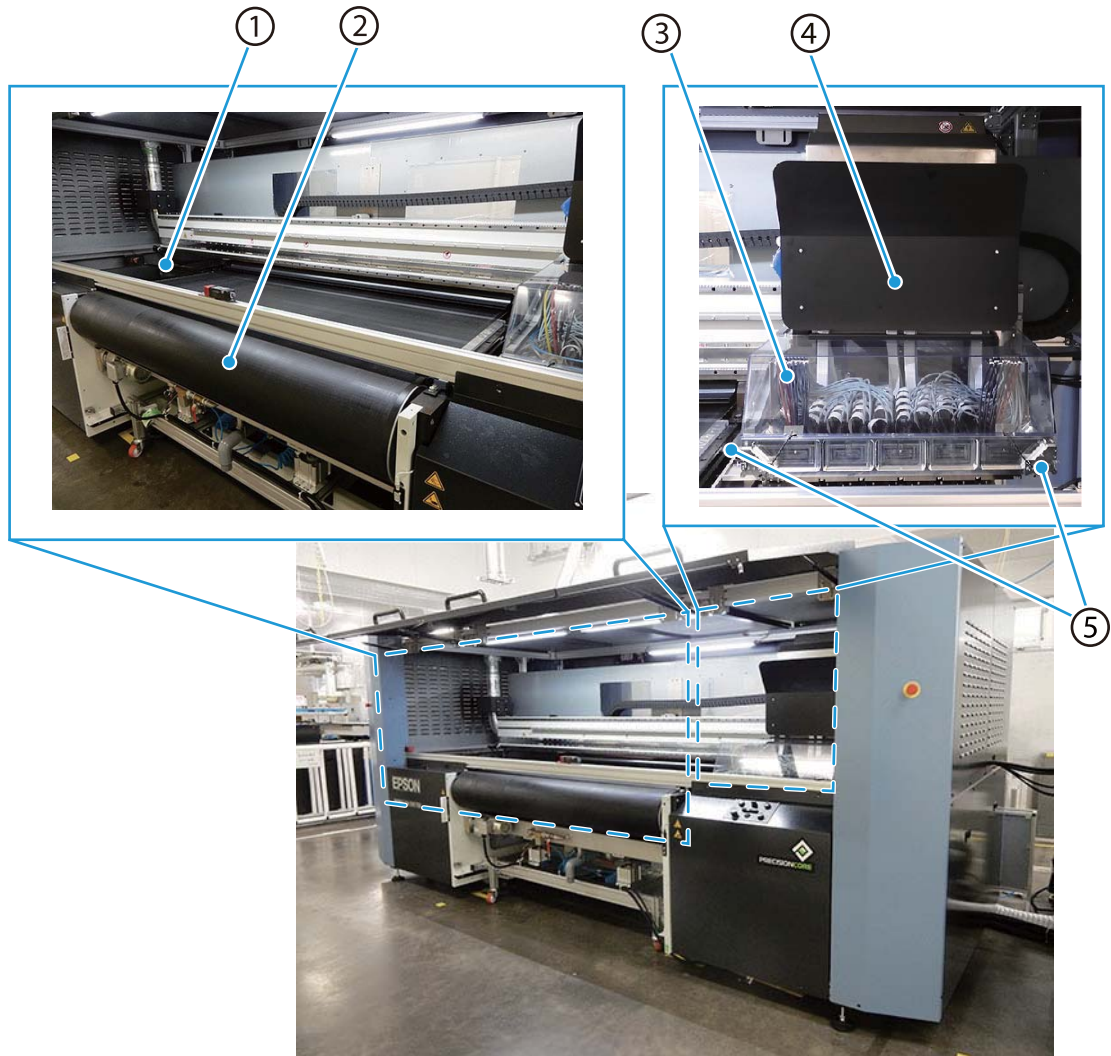

No.	Name	Description
1	Flushing area	This contains the flushing plate, and the print head performs flushing here.
2	Belt	This belt feeds fabric attached to it.
3	Print Head	Equipped with the print head used for printing on fabric.
4	Cooling fan	Lowers the temperature of the print head control substrate.
5	Head stroke sensor	Detects foreign material on the belt as well as folds and wrinkles in the fabric.

Rear

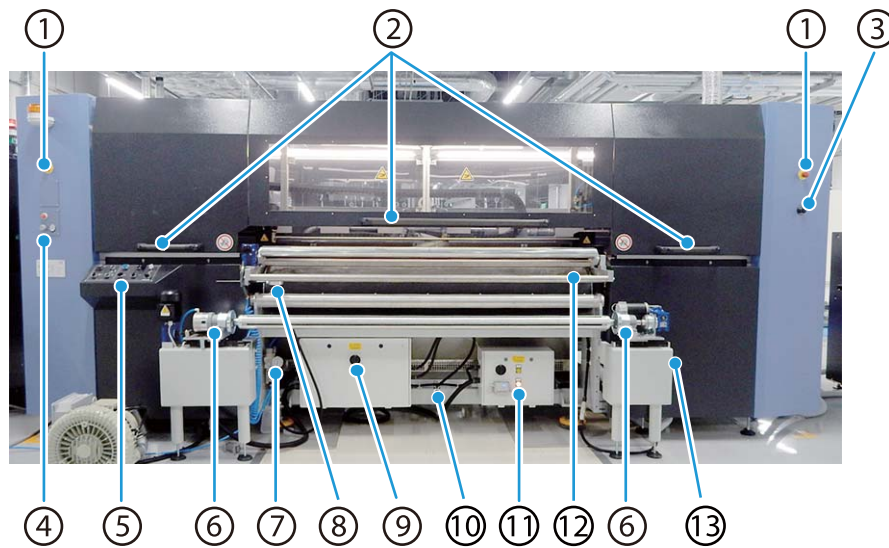

No.	Name	Description
1	Emergency stop button	Stops operation of this machine immediately.
2	Rear Protection Covers	These are movable covers. Open these covers to perform maintenance.
3	Pause button	Printing is paused and the print head stops in the flushing area or the cleaning station area.
4	Fabric tension adjustment panel	Use this panel to adjust the winding tension of the fabric.
5	Rear panel	Location of the operating panel for performing operations on the rear of the machine.
6	Feeding unit	The fabric roll is installed here, and the unit feeds the fabric into the machine.
7	Air supply regulator	This regulator supplies compressed air.
8	Fabric edge sensor unit	This sensor detects the left edge position of the fabric.
9	Electric box for feeding unit	This box supplies power to the feeding unit.
10	Slack sensor	This sensor detects slack in the fabric.
11	Electric box for belt heater unit	This box supplies power to the belt heater unit.
12	Towel roller	This roller makes contact with the belt during printing to wipe water droplets of the belt.
13	Slack adjustment switch	In slack mode, the machine feeds out fabric to create slack.

Rear (When opening the rear protective covers)



No.	Name	Description
1	Pressure Roller	This roller swings above the fabric that is fed from the fabric guide bar, to affix the fabric to the belt.
2	Fabric guide bar	Fabric that is sent from the dewrinkling roller is lowered to the height of the belt and guided to the pressure roller.
3	Dry air system	This system supplies dry air for adjusting print head humidity.

Tower Lamps and Rotary Beacon

Tower lamps

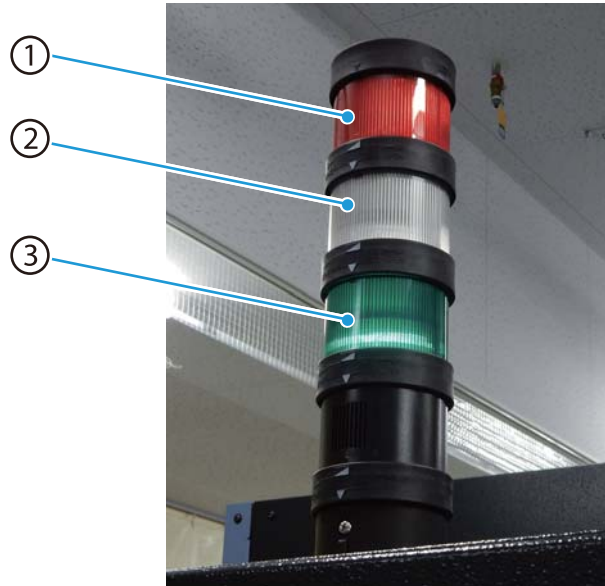

No.	Name	Description
1	Red	On: Fault status (Emergency stop or device error)
2	White	Flashing: Machine currently operating
3	Green	On: Printing standby status Flashing: Printing paused status

Rotary beacon



No.	Name	Description
1	Rotary beacon	Lights up and the buzzer sounds if the rear protection covers are opened while the machine is printing.

Ink rack (3L)

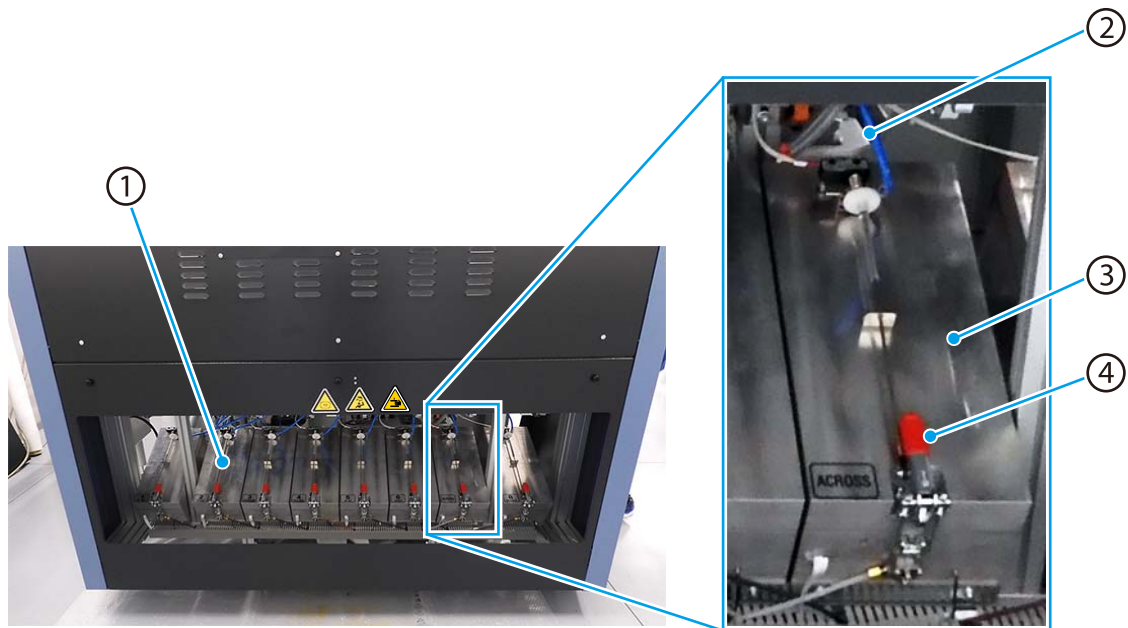

No.	Name	Description
1	Ink tank	Contains a 3L ink cartridge.
2	Cover support hook	Used to hook the tank opening/closing handle when the ink tank cover is open.
3	Ink tank cover	Ink tank cover. Open/close this cover when replacing the ink cartridge.
4	Tank opening/closing handle	Pull this handle to unlock the ink tank cover so that the ink tank cover can be lifted.

Inside of ink tank

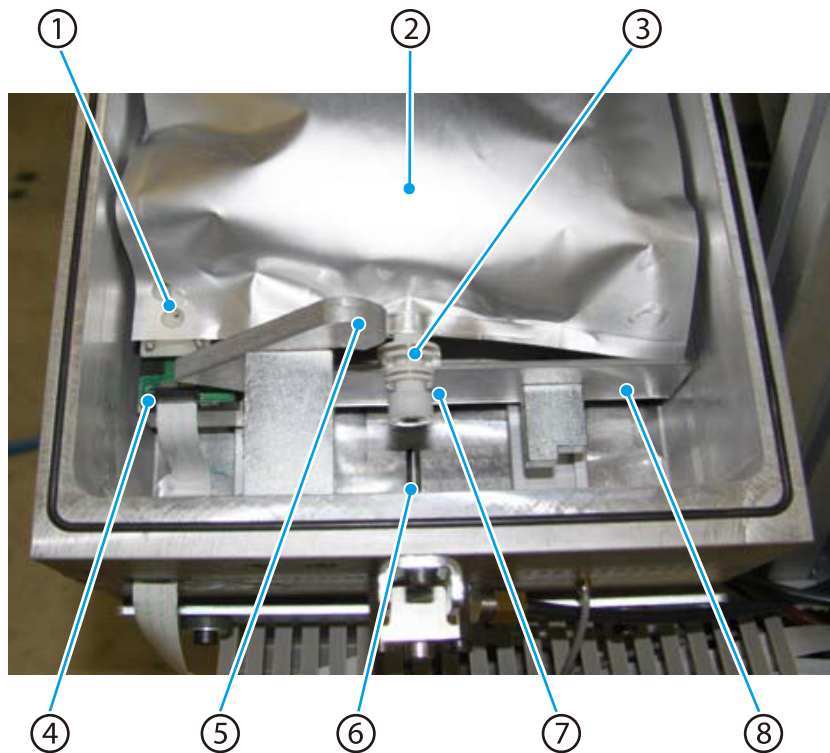

No.	Name	Description
1	IC chip	Connected to the reader to send information of the ink cartridge.
2	Ink cartridges	Ink cartridge that contains ink.
3	Ink cartridge supply port	Supplies ink from the ink cartridge to the machine.
4	Reader	Connected to the IC chip on the ink cartridge.
5	Lever	Used to lock the cartridge carriage.
6	Needle	Connected to the ink cartridge supply port.
7	Supply port securing section	Secures the ink cartridge supply port in position with the cutout on the cartridge carriage.
8	Cartridge carriage	The ink cartridge is placed on this carriage.

Ink rack (10L)



No.	Name	Description
1	Ink rack	<p>Ink is supplied from the ink cartridges to the sub-tank rack in the ink tank housing of the machine.</p> <p>The lamps on the bottom right side of each cartridge indicate when to replace that cartridge.</p> <p>Green lamp: There is ink remaining in the cartridge. Ink is being supplied to the ink rack.</p> <p>Red lamp: There is no ink remaining in the cartridge. Replace the ink cartridge.</p> <p>The amount of ink remaining is shown on Leonardo. If a cartridge needs to be replaced, a message is displayed on Leonardo.</p>
2	Ink cartridges	<p>These are 10 L ink cartridges.</p> <p>They are mounted in the ink rack.</p> <p>For information about the layout of colors, please refer to the Delivery Specifications.</p>
3	Ink rack front bar	Prevents the ink cartridges from falling out.

Control Panel

Main electric panel

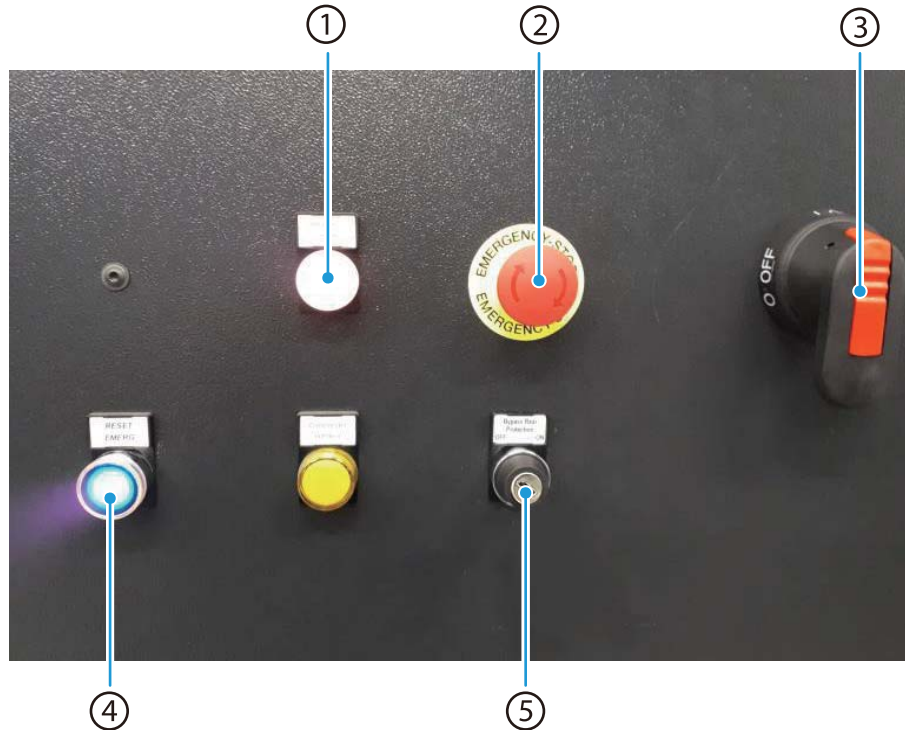

No.	Name	Description
1	Lamp (White)	When this lamp is on, power is supplied to the main circuit.
2	Emergency stop button	Stops operation of this machine immediately.
3	Main switch	Used to switch on/off the power to the main unit.
4	Reset	Press this button after selecting Set Point to start the Set Point operation.
5	Maintenance	Used when performing glue application work.



If the power is turned on while the key is still inserted, the belt operation safety function during printing (device operation) will be disabled, resulting in a dangerous situation. Therefore, do not insert the key except for when applying glue for maintenance work. The key must be kept by the person authorized by the employer and must never be left inserted in the electrical panel.

Front panel

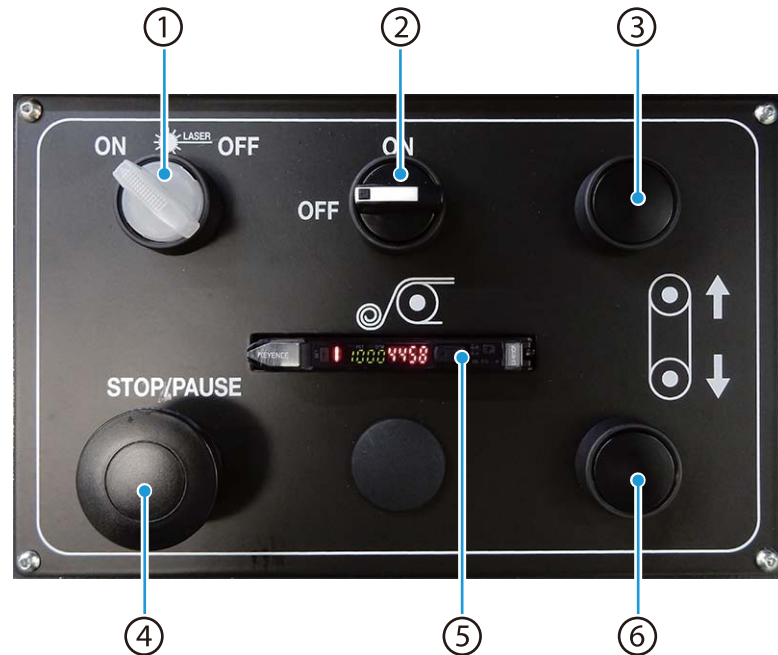

No.	Name	Description
1	Selection switch (White lamp)	Use this switch to turn ON/OFF the foreign material detection sensor. The manufacturer recommends not switching off this function except to overcome the obstacle. Epson do not assume any responsibility in case of misuse of the foreign material detection sensor.
2	Selection switch (Black)	Use this switch to enable/disable the signal from an external winder.
3	Belt feed button (Reverse)	Press and hold this button to feed the belt in the reverse direction.
4	STOP/PAUSE	Press this button to pause printing. The head comes to a stop at either the flushing area or the cleaning station. Press the [Start] button on Leonardo to resume printing.
5	Foreign material detection sensor display	Use this display to set the detection threshold value of the foreign material detection sensor and display the threshold value. For threshold values, refer to "Set the Foreign Material Detection Sensor" on page 108.
6	Belt feed button (Forward)	Press and hold this button to feed the belt in the forward direction.

Rear panel

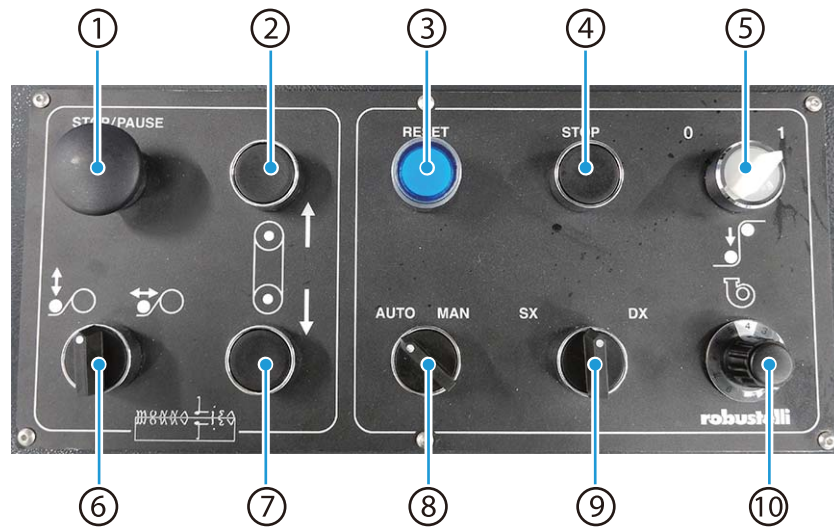

No.	Name	Description
1	STOP/PAUSE	Press this button to pause printing. The head comes to a stop at either the flushing area or the cleaning station. Press the [Start] button on Leonardo to resume printing.
2	Belt feed button (Forward)	Press and hold this button to feed the belt in the forward direction.
3	Button (Blue lamp)	Press this button to turn ON the feeding unit. (Turn on when enabling slack mode or fabric meandering correction.)
4	Button	Press this button to turn OFF the feeding unit.
5	Selection switch (White lamp)	Use this switch to turn ON (1) / OFF (0) the functions for detecting slack in fabric that is fed and for communicating with the feeding unit.
6	Selection switch (Black)	Use this switch to change the operating direction of the pressure roller. Left: Moves vertically. Right: Moves horizontally.
7	Belt feed button (Reverse)	Press and hold this button to feed the belt in the reverse direction.
8	Selection switch	Use this switch to fabric meandering correction to AUTO/ MAN (MANUAL).
9	Selection switch	Use this switch to move the position of the set fabric left and right. This switch is enabled only when the selection switch in No. 8 is set to MANUAL. SX: Moves the position to the left. DX: Moves the position to the right.
10	Volume	Use this control to adjust the conveyor belt speed while glue is applied.

Fabric tension adjustment panel

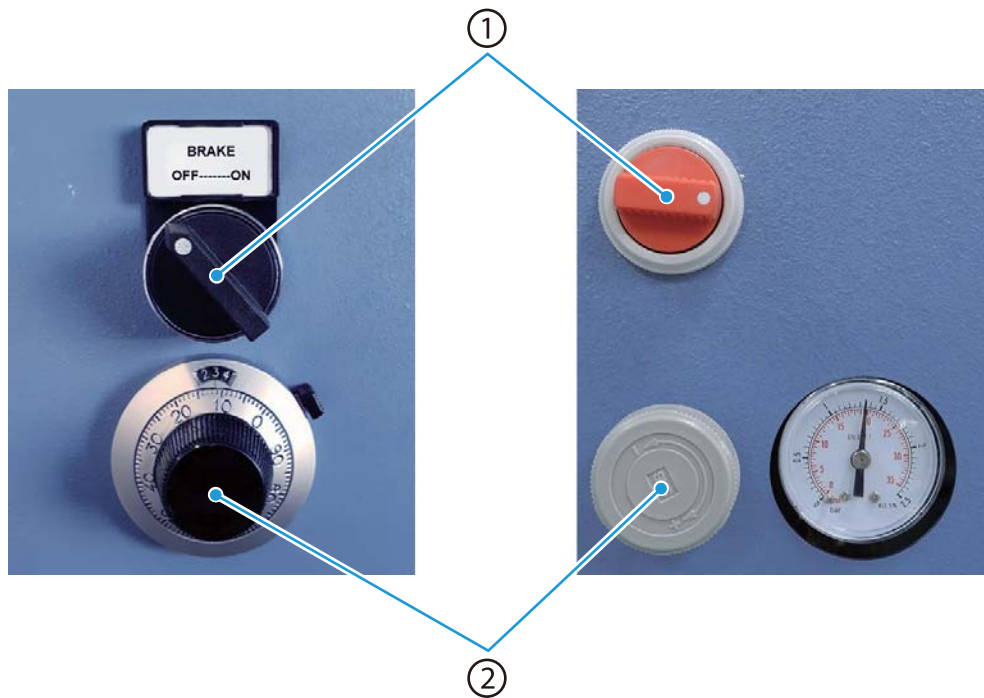

No.	Name	Description
1	Switch	Use this switch to turn OFF (Left)/ON (Right) the tension adjustment function for winding the fabric.
2	Dial	Use this dial to adjust the winding tension of the fabric.

Workflow before Beginning Work

This section describes the items to be checked before beginning work.

Workflow

Operations and Check Items for Rear Side

1. Checking the Air Pressure ([Page 63](#))
2. Removing the Stopper Pin of the Pressure Roller ([Page 64](#))
3. Lowering the Towel Roller ([Page 65](#))

Operations and Check Items for Front Side

1. Supply Water to and Check the Belt Cleaning Unit ([Page 67](#))
2. Check the Amount of Waste Ink Remaining in the Waste Ink Tank ([Page 68](#))

Other

1. Prepare the Fabric ([Page 69](#))
2. Adjusting the Fabric Peeling Prevention Bar ([Page 70](#))
3. Checking Operating Parts ([Page 74](#))
4. Checking the Exhaust Equipment ([Page 75](#))

Procedure for Turning on the Power

1. Pushing an Emergency Stop Button for an Emergency Stop ([Page 76](#))
2. Turning On the Power ([Page 76](#))
3. Starting Leonardo ([Page 77](#))
4. Releasing an Emergency Stop Button ([Page 78](#))
5. Executing Set Point ([Page 79](#))

Operations and Check Items After Turning on the Power

1. Check the Operation of the Emergency Stop Equipment ([Page 80](#))
2. Inspect for Leaks in the Ink Path ([Page 81](#))
3. Inspect the Open Cover Detection ([Page 83](#))
4. Nozzle Check ([Page 84](#))
5. Head Cleaning ([Page 87](#))

Checking the Air Pressure

Compressed air must be supplied in order for the machine to operate. The machine will not operate if the specified air pressure is not supplied. An air pressure that is higher or lower than the specified air pressure could cause the machine to malfunction.

1 Confirm that the pressure indicated by the Air Supply Regulator on the rear of the machine is within the specifications range. ([Page 34](#))

If it is not within the specifications range, check the status of the compressed air equipment in the factory.



Removing the Stopper Pin of the Pressure Roller

- 1 Open the rear protection cover.
- 2 Remove the stopper pin located at the lower part on the right side of the pressure roller.



- 3 Remove the stopper pin on the left side of the pressure roller.



- 4 Close the rear protective covers.

Lowering the Towel Roller

If the towel roller is installed, lower the towel roller until it touches the belt.



The supporting screw sticking out into the towel roller groove supports the towel roller spindle and prevents it from lowering.

While the towel roller is in the upper position, it is placed on the supporting screw sticking out into the groove to prevent the spindle from lowering.

Towel roller in upper position

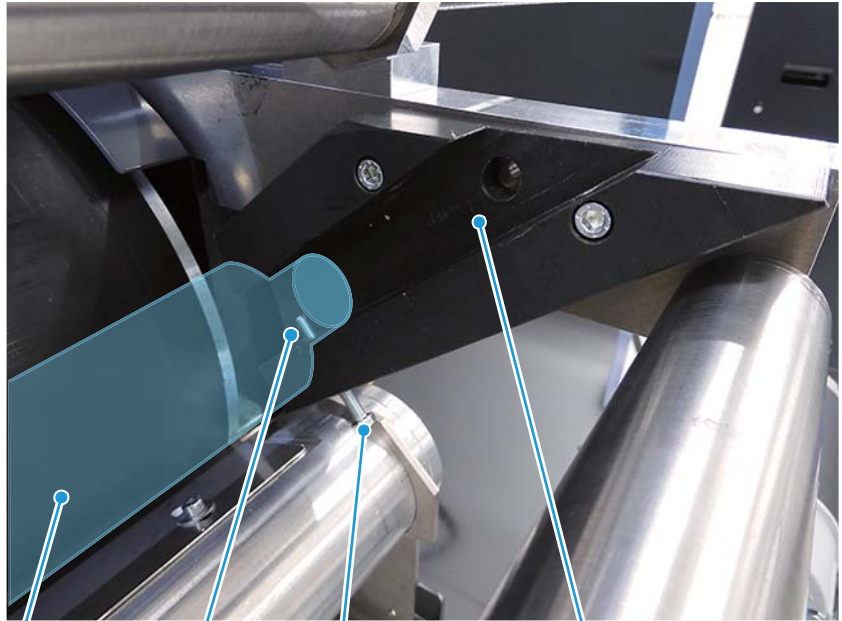

Towel roller



Supporting screw

Towel roller groove

Supporting screw sticking out into the groove supports the towel roller spindle

To lower the towel roller, loosen the supporting screw so that the towel roller spindle can pass through the groove.

- 1 While lifting up the right side of the towel roller toward you, loosen the supporting screw (right) by hand.

 CAUTION	When the screw is loosened, the towel roller automatically lowers under its own weight. Be careful not to get your fingers caught between the towel roller and the belt.
	There is no need to remove the supporting screw. You can lower the towel roller only by loosening the screw.

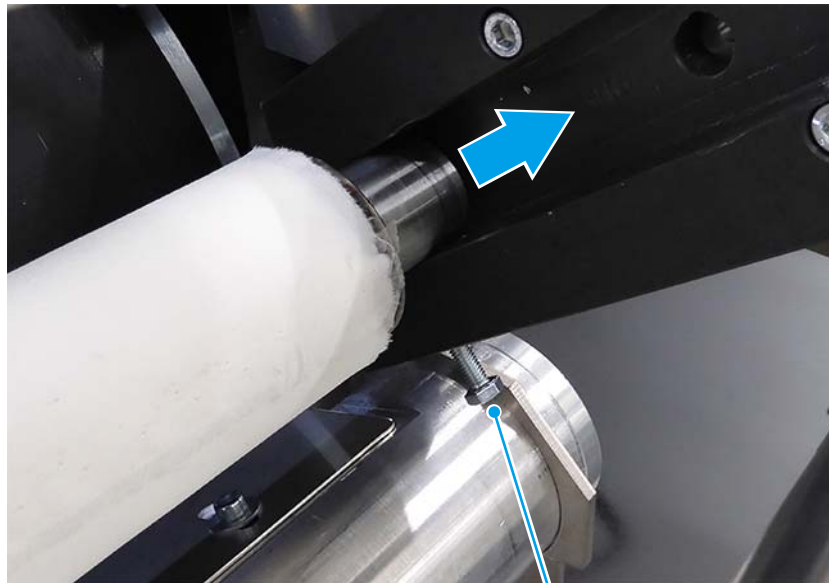

Supporting screw

- 2 Lower the towel roller gradually along the groove until it touches the belt.



- 3 Repeat procedures 1 and 2 on the left side of the towel roller.

Supply Water to and Check the Belt Cleaning Unit

The belt cleaning unit washes ink from the belt and dries the belt.

Opening the Water Supply Valve

Open the water supply valve at the bottom of the front of the machine.

Adjust the open/close amount to match the use conditions.

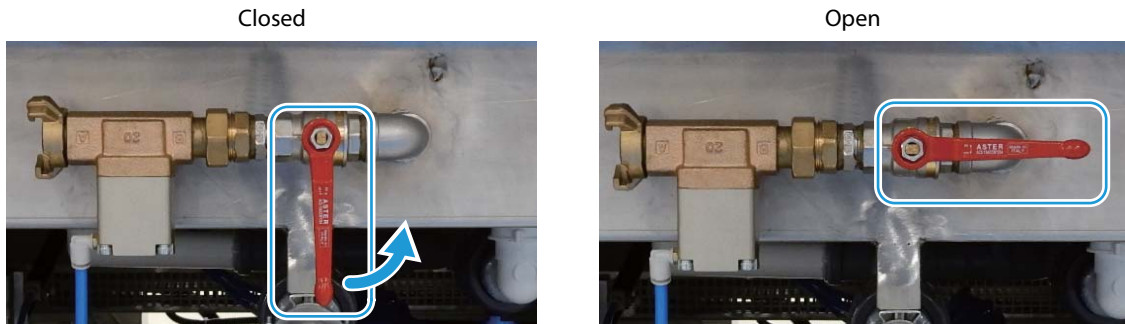

The belt cleaning unit will not operate until printing starts.
 For operation check, refer to ["Check the Belt Cleaning Unit Operation" on page 135](#).
 For the pressure of the water supply, refer to ["Power" on page 34](#).

Belt Checking the Belt on the Cleaning Unit

Check if the cleaning brushes, pads, and scrapers are dirty or worn. For more information, refer to the "Maintenance Guide".

Check the Amount of Waste Ink Remaining in the Waste Ink Tank

If there are waste ink tanks, check if there is room remaining in the waste ink tanks. If there is little room remaining in a waste ink tank, dispose of the waste ink before beginning work. For more information about how to dispose of waste ink in a waste ink tank, refer to the "Maintenance Guide".



This step is not required if there are no waste ink tanks (if the waste ink is connected directly to the drainage path).

Check the amount of waste ink in the waste ink tanks in the flushing area and cleaning station.





Waste ink tank on the flushing area side

Waste ink tank on the cleaning station side

Prepare the Fabric

Before setting the fabric, be sure to confirm the following status.

- **Fabric edge:** Confirm that there are no folds or protrusions and that the fabric is not lifted up or frayed. If the fabric is frayed, perform overcasting.
- **Seams:** Confirm that there are no protrusions and that the fabric is not frayed.

 WARNING	<p>If the fabric touches the head, the head may be damaged. The fabric must be fed and adhere to the belt without any folds, protrusions, seams, or lifting in the fabric edge whatsoever.</p>
 CAUTION	<p>If the fabric thickness and print head height are set incorrectly, the print head may collide with the fabric, resulting in a malfunction. Set the fabric thickness and the foreign material detection sensor when loading the fabric for the first time or changing the fabric type or thickness. For more information about fabric thickness, refer to "Set the Fabric Thickness and Head Height" on page 111. For more information about the foreign material detection sensor, refer to "Set the Foreign Material Detection Sensor" on page 108.</p>

If fiber containing moisture from the ink lifts up, it may come into contact with the head passing over the fabric. To avoid this, make the fabric edge firmly adhere to the belt.

Adjusting the Fabric Peeling Prevention Bar

The fabric peeling prevention bar is installed 5 mm above the belt. Depending on the thickness of the fabric, the fabric might not be able to pass below the fabric peeling prevention bar, causing a collision with print head and malfunctions. Adjust the height of the fabric peeling prevention bar whenever changing the fabric type or thickness.

- 1** Open the front protection cover.
- 2** Use a hex key (width: 4 mm) to loosen the screws on the fabric peeling prevention bar (4 screws) about half one rotation.



3 Lift the bar up from the belt to about 3 to 5 mm above the fabric thickness.



If using a ruler for measuring, be careful not to let the ruler get caught on the belt. Doing so could scratch or damage the belt.



- 4** Holding the bar in one hand, use a hex key (width: 4 mm) to tighten the rightmost and leftmost screws on the fabric peeling prevention bar.

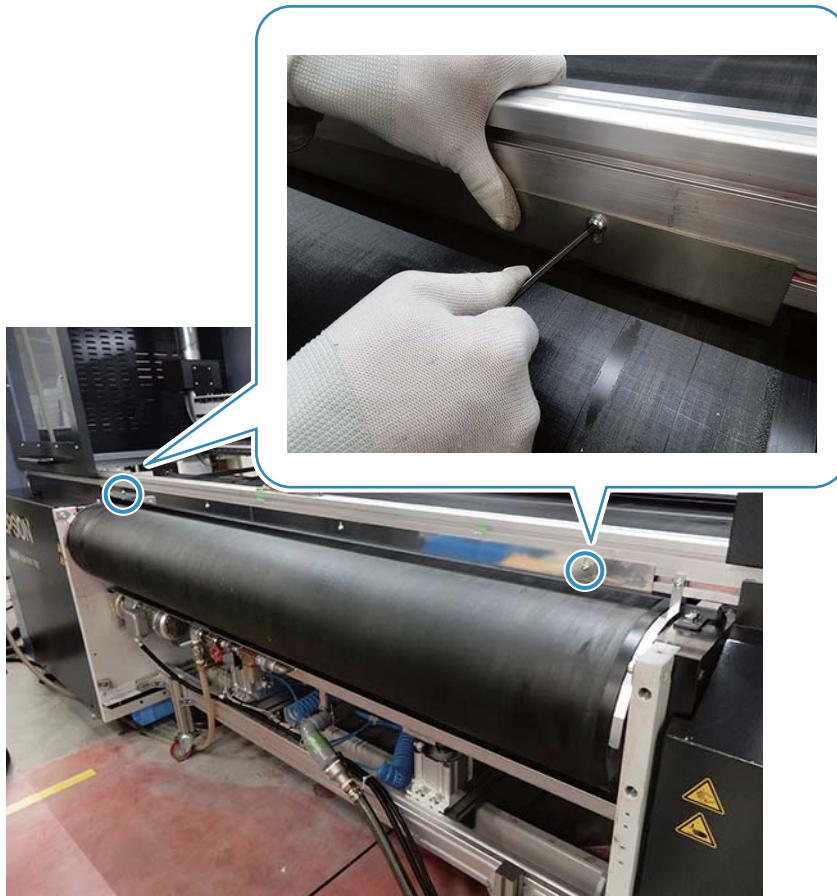

- 5** Use a hex key (width: 4 mm) to tighten the remaining screws on the fabric peeling prevention bar.



- 6** Close the front protection cover.

Checking Operating Parts

Do not place tools, fasteners, or the like on the belt or near the pressure roller or print head. Doing so could cause them to be entangled in the belt, pressure roller, or print head, damaging this machine. Before turning the power on, check that there is nothing left near the moving parts, such as on the belt or near the print head.

Front

- 1 Open the front protection cover of this machine.
- 2 Check that there are no tools, fasteners, or the like left on the belt or near the carriage or print head.



- 3 Close the front protection cover.

Rear

- 1 Open the rear protection cover of this machine.
- 2 Check that there are no tools, fasteners, or the like left near the belt or the pressure roller.

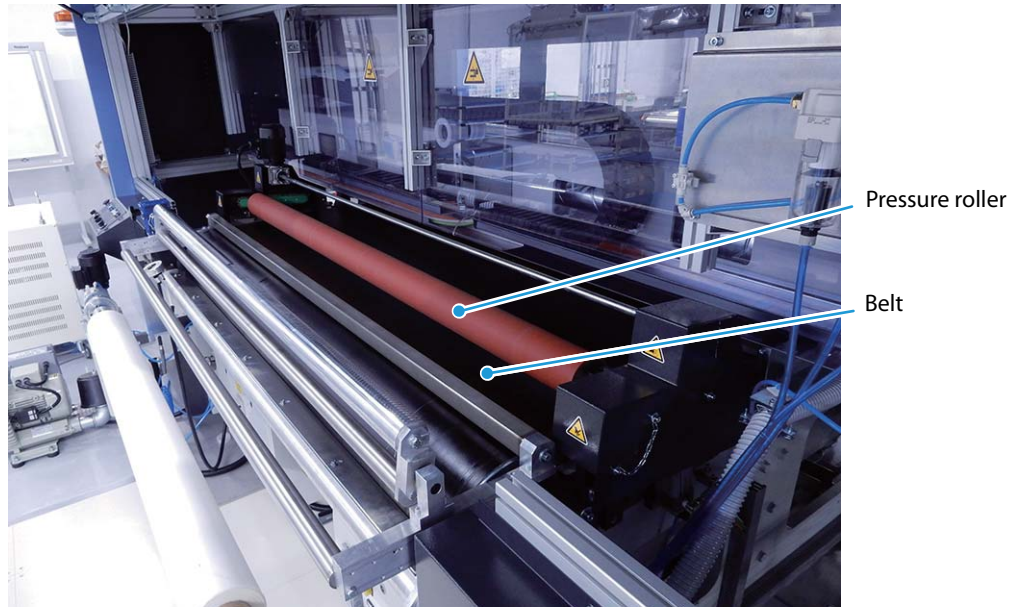

- 3 Close the rear protection cover of this machine.

Checking the Exhaust Equipment

Check if the exhaust is flowing while the machine is running, in order to adjust the temperature and humidity of the machine.

The location and method of checking exhaust ducts will vary depending on the equipment that is used. For details, please check with the factory manager.



Pushing an Emergency Stop Button for an Emergency Stop

Push the emergency stop button to put the machine in emergency stop status, so that the print heads and motor do not operate suddenly when the power is turned on.

Emergency stop buttons are found in five locations around the machine. Firmly press one of these emergency stop buttons.



Turning On the Power

 CAUTION	<p>Confirm that the key is not inserted in Maintenance.</p> <p>If the power is turned on while the key is still inserted, the belt operation safety function during printing (device operation) will be disabled, resulting in a dangerous situation. Therefore, do not insert the key except for when applying glue for maintenance work.</p> <p>The key used for the maintenance for glue re-application must be in a safe and locked place and under the full responsibility of the person in charge of.</p>
	<p>Confirm that front protection covers and rear protection covers are closed before turning on the power.</p>

Turn on the power. Turn the Main Power Switch on the Main Electric Box to 1 (ON).

Confirm that the lamp (white) lights up.

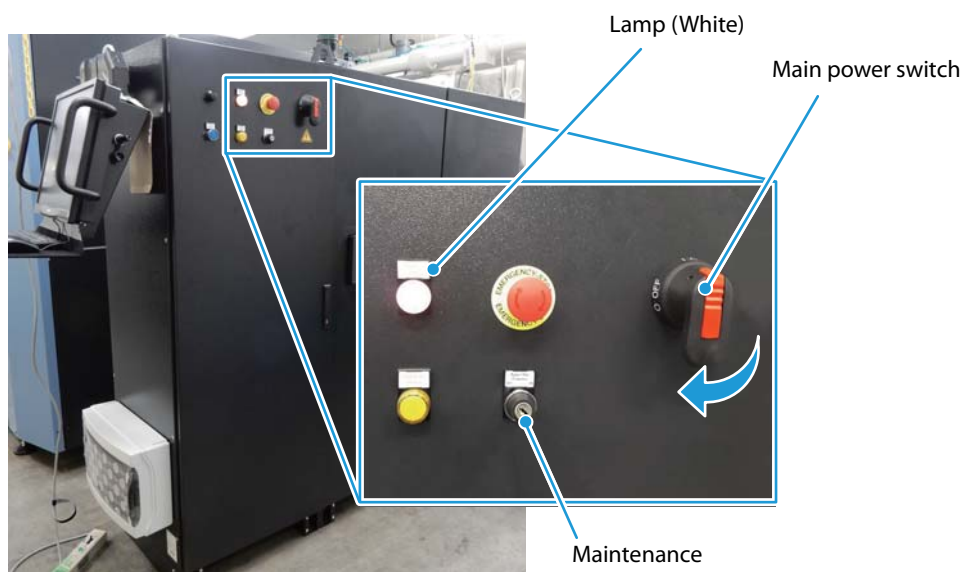

The red LED on the tower lamp also comes on.

Starting Leonardo

This machine is controlled by Leonardo on a Control PC.

- 1 When the power to the machine is turned on, the Control PC starts. Wait for Windows to start on the PC.
- 2 The Windows startup screen appears on the display of the control PC. After Windows starts, Double-click the Leonardo icon on the desktop to start Leonardo.

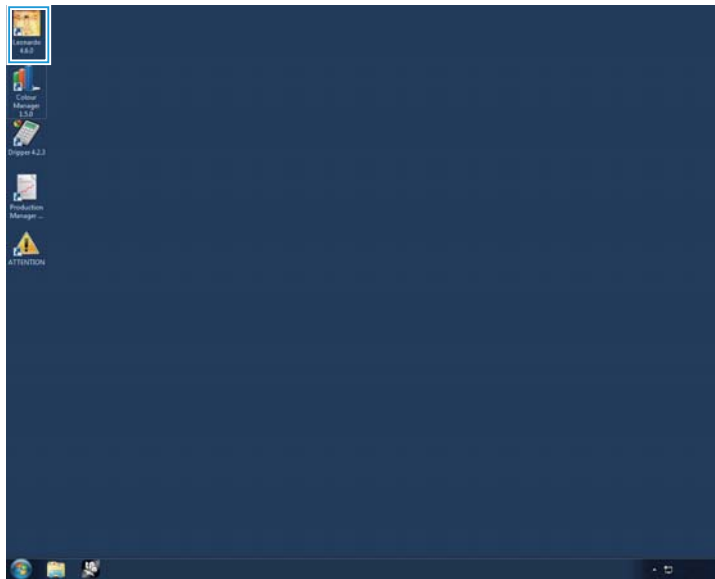

CAUTION

Do not add Leonardo to the Startup settings in the OS. Leonardo may not function properly if added to the Startup settings.

- 3 When Leonardo starts, the "Machine in Emergency" and "Ready to start" messages are displayed on the status bar.



Releasing an Emergency Stop Button

Turn the Emergency Stop Button to the right to release the emergency stop status.



Set point cannot be executed if any emergency stop button has been pressed because the emergency stop condition has not been released.

Confirm that all of the following emergency stop buttons have been released.

- Five emergency stop buttons of this machine
- Emergency stop buttons for devices linked to this machine (If there are linked devices)

Executing Set Point

Set a Set Point (origin position) before printing in order to print at the correct coordinates.

Immediately after turning on the power, releasing an emergency stop button, replacing fabric, adjusting the print heads, and/or performing head cleaning, be sure to execute Set Point before printing.

1 In Leonardo, click the [Setpoint] icon.



2 Press the reset button on the main electric box.

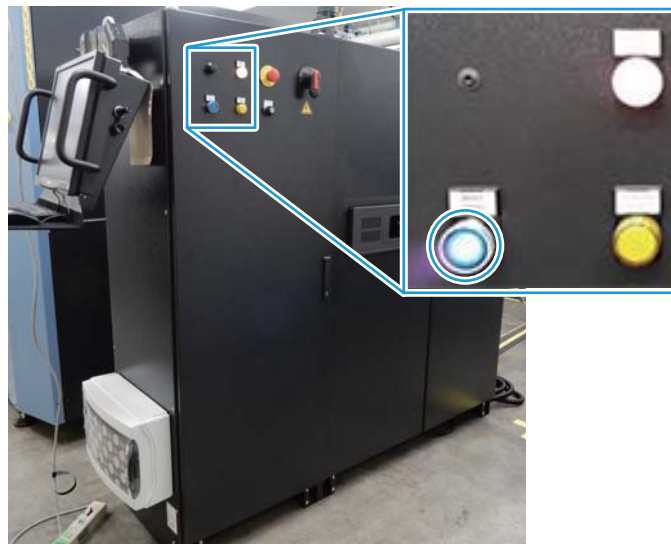

3 The print heads move, and the origin position is set. At this time, "Setpoint in progress" is displayed in the status bar of Leonardo and the tower lamp changes from red to white.

When Setpoint is completed, the tower lamp changes from white to green.



If the print heads do not operate even after executing Set Point, please confirm the following.

- All of the emergency stop buttons have been released.
 - * Five emergency stop buttons of this machine.
 - * Emergency stop buttons for devices linked to this machine (If there are linked devices).

Check the Operation of the Emergency Stop Equipment

Check all emergency stop functions in the system.

Checking the Emergency Stop Buttons on the Machine

- 1 Press an Emergency Stop Button.
- 2 Confirm that "Machine in emergency" is displayed on the status bar in Leonardo, and that the tower lamp is red.
- 3 Turn the Emergency Stop Button to the right to release the emergency stop status.



- 4 Executes Set point.
See ["Executing Set Point" on page 79](#).
- 5 Confirm that the tower lamp is green.
- 6 **There are five emergency stop buttons around the machine.**
Repeat procedures 1 to 5 to check the operation of each emergency stop button.

Checking the Emergency Stop Functions in the System

If the system is linked with the emergency stop system of other equipment, check if the system's emergency stop function for that equipment is operating normally.

Inspect for Leaks in the Ink Path

Inspect if there are any ink leaks in each ink path.

Print heads

Visually check the area round the Print Heads on the front of the machine.



Ink rack (3L)

Visually check the area around the ink rack.

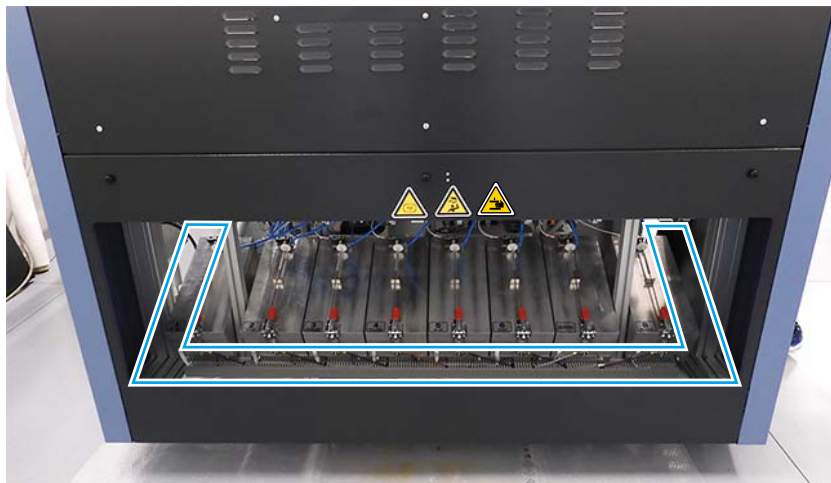

Ink rack (10L)

Visually check the area round the ink rack on the rear left side of the machine.



Inspect the Open Cover Detection

Front Protection Covers

Open each of the 3 protective covers on the front of this machine and confirm that "Front protection open" is displayed on the status bar in Leonardo.

Rear Protection Covers

Open each of the 3 protective covers on the rear of this machine and confirm that "Rear protection open" is displayed on the status bar in Leonardo.

Nozzle Check

Before printing, perform a nozzle check to make sure the nozzles are engaged. If a nozzle is not engaged, perform head cleaning.

	<p>Use an acrylic board for the nozzle check, because the ink grains are very fine. Fabric can also be used, but makes it difficult to determine if a nozzle is not engaged.</p> <p>Items required:</p> <ul style="list-style-type: none"> • Acrylic board • Ruler / tape measure (to measure the distance from the edge of the print area to the edge of the paper)
---	--

Setting the Acrylic Board

This step is not necessary when printing directly on fabric.

- 1 Open the front protection cover.**
- 2 Affix the acrylic board to the printing area. Affix the acrylic board along the right edge, because the origin of the print heads is on the right side.**



	<p>The horizontal printing margin can be set in Leonardo, and therefore it is not necessary to set the right edge of the printing area to the affixing position.</p> 
---	---

3 Measure the distance from the edge of the belt (right side).

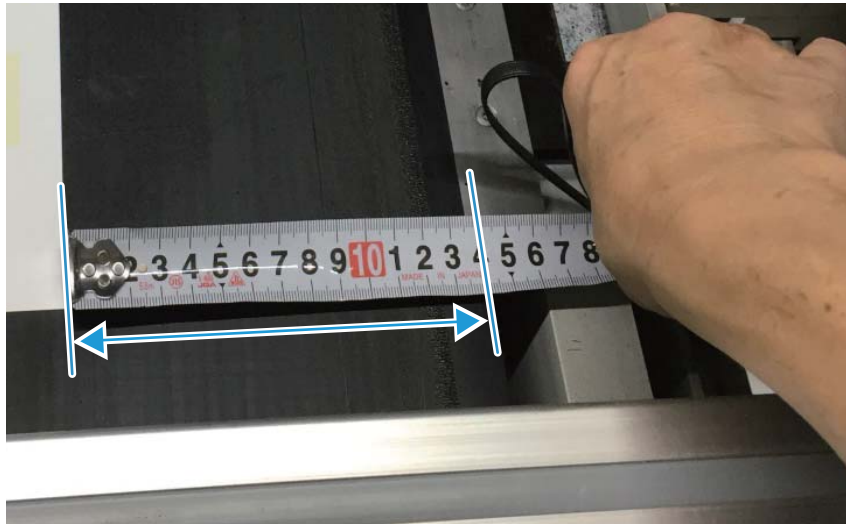

4 Close the front protective covers.

Printing the Nozzle Check Pattern

Set the print start position and ink size in [Maintenance].



Item	Description
Start printing	Enter the length from the right edge of the printing area to the point where printing begins. (Units: mm)
Drop size	Select the drop size. If the check pattern is too fine and difficult to determine, select Large.
Nozzle check	Prints the check pattern.
Extra mode	Increase the amount of ink for the check pattern.

Click [Nozzle check] to print the check pattern.

Confirmation Method

Check the nozzle check pattern that is printed.

If all nozzles are engaged and operation is normal, all of the lines will be printed.

The photo shows a printing result with EVO TRE 16-180. The printing result varies depending on the model.

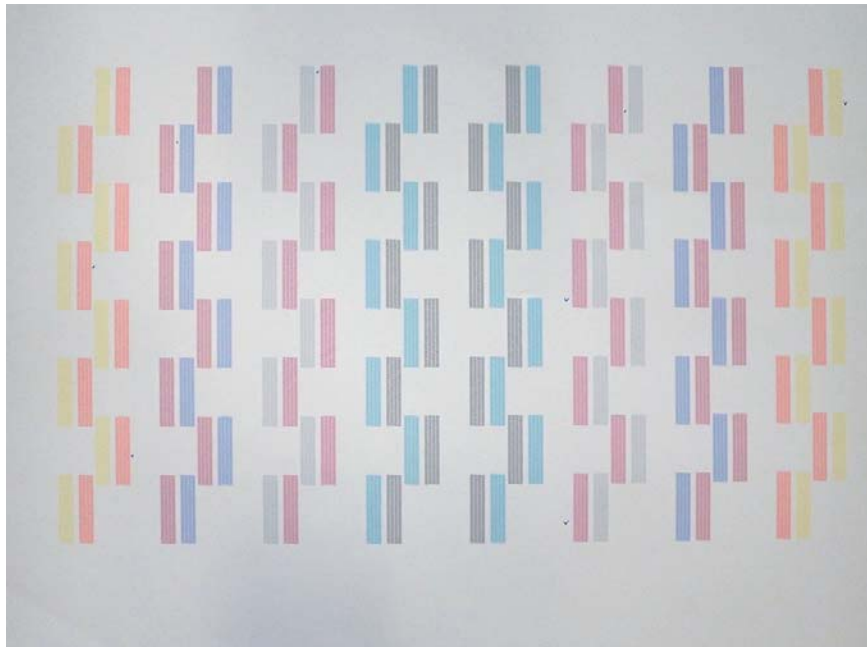

If a nozzle is not engaged (there are areas that are not printed), actual printing could be affected. In that case, perform head cleaning.



The nozzle check does not guarantee print quality.

If the nozzle check pattern has mixed colors, perform manual flushing. For more information, refer to "[Manual flushing](#)" on page 147.

Head Cleaning

Use one of the following procedures to perform head cleaning.

- Cleaning with Leonardo (recommended)
- Manual cleaning: Refer to the "Maintenance Guide".

Cleaning with Leonardo

Make the required settings in the [Maintenance] menu to perform cleaning.

1 Click [Maintenance].



2 Under [Intensity], select the strength of head cleaning.

First, perform cleaning in [Normal]. If it does not recover, try cleaning in [Medium]. If it still does not recover, clean in [Extra].



Item	Description
Normal	Use this setting for standard head cleaning.
Medium	Use this setting if the problem is not resolved on the Normal setting. A greater amount of ink is used than for the Normal setting.
Extra	Use this setting if there are bubbles in the ink tube. Because most of the ink in the ink path is discharged, this setting uses a very large volume of ink.

3 Under [Head Cleaning], select the heads to be cleaned, and then start head cleaning.



Item	Description
Complete	This setting cleans all of the heads.
Colour Selection	Select the ink colors for which you want to perform cleaning.

Print Workflow

This section describes the workflow for printing.

Workflow

Setting the Fabric

1. Set the Fabric ([Page 90](#))
2. Set the Foreign Material Detection Sensor ([Page 108](#))
3. Set the Printer ([Page 111](#))

Printing

1. Load the Print Data ([Page 114](#))
2. Set the Print Data ([Page 116](#))
3. Printing ([Page 118](#))
4. Stopping Printing ([Page 120](#))

Others

1. Replace the Ink ([Page 121](#))
2. Changing User Permissions ([Page 134](#))
3. Check the Belt Cleaning Unit Operation ([Page 135](#))

Set the Fabric

Installing the Fabric



WARNING

The fabric must be as smooth and firm as possible. If the fabric edge is fraying and threads are loose, the fiber may come into contact with the head, damaging the head. In the same way, be sufficiently careful to prevent protrusions and fraying at the seam between pieces of fabric.

1 Open the rear protective cover.



WARNING

The machine can operate at a decelerated rate even when the rear protective cover is open. However, use this only in special circumstances. Be particularly careful to avoid your finger being pulled or crushed by the moving pressure roller.

When you open the rear protective cover, the machine decelerates for operation, and the rotary beacon light flashes in orange to notify you.

2 Confirm that the pressure roller is lifted up. If the pressure roller is lowered, turn the selection switch (black) to the left and lift up the roller.

3 Remove the fabric spindle for procedures 3 to 6. Rotate the fabric spindle and align it with the lock release position.

Correct position

Air inlet is visible

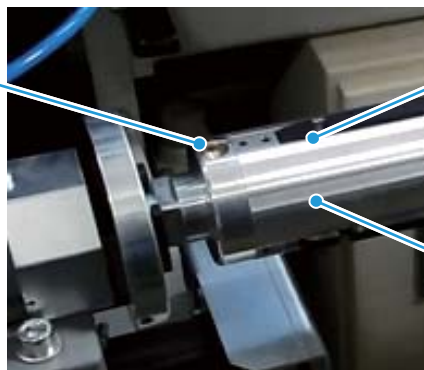

Stopper

Fabric spindle

Incorrect position

Air inlet is not visible

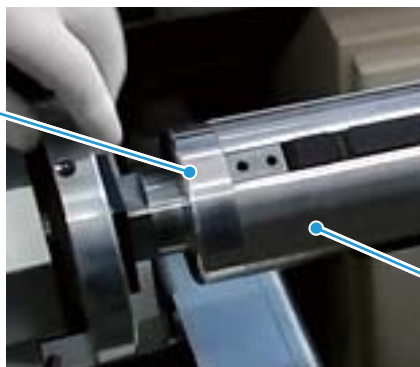

Fabric spindle

- 4 Press the center of the air inlet of the spindle to release the air and loosen the spindle stopper.
- 5 Release the locks on the left and right sides of the feeding unit. This allows the fabric spindle to be removed.

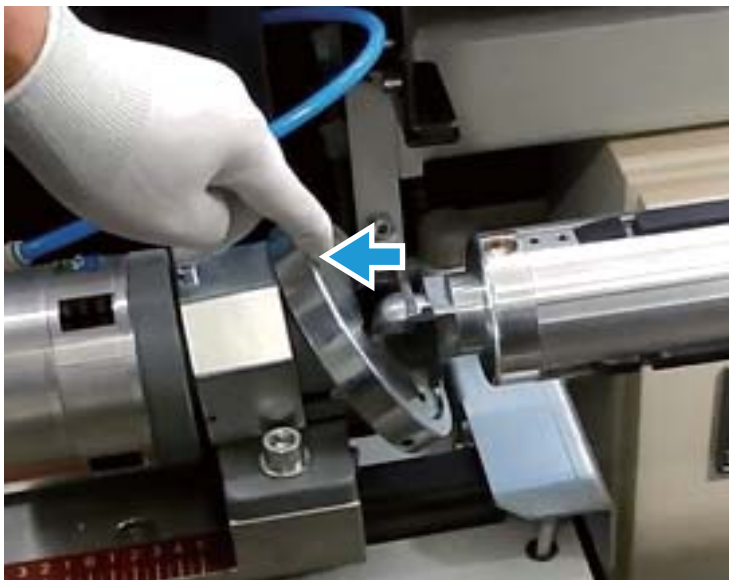

- 6 Remove the fabric spindle, and replace the fabric.
- 7 Set the new fabric on the spindle.

**CAUTION**

Fabric rollers that weigh 20 kg {44.1 lb} or more should be set by two people.

- 8 Set the fabric in the feeding device. Fit the fabric spindle into the groove on the feeding device.



9 Lock the feeding device.

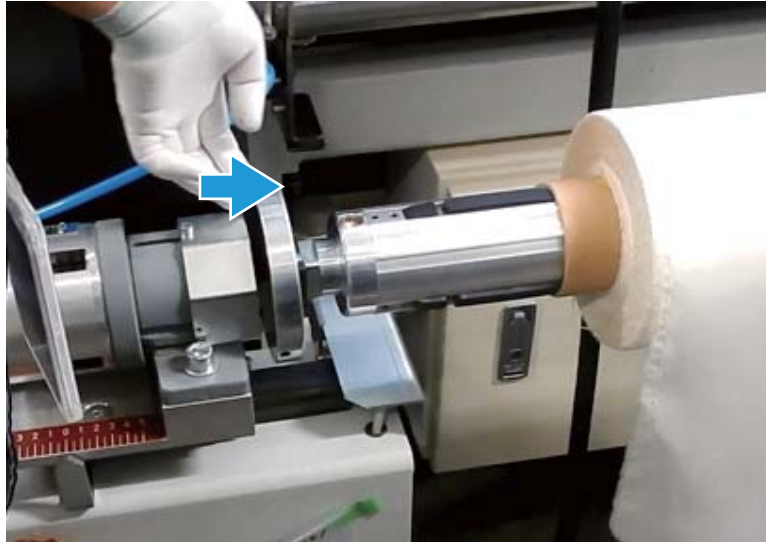

10 Adjust the lateral position of the fabric. Align the fabric center with the printer center.

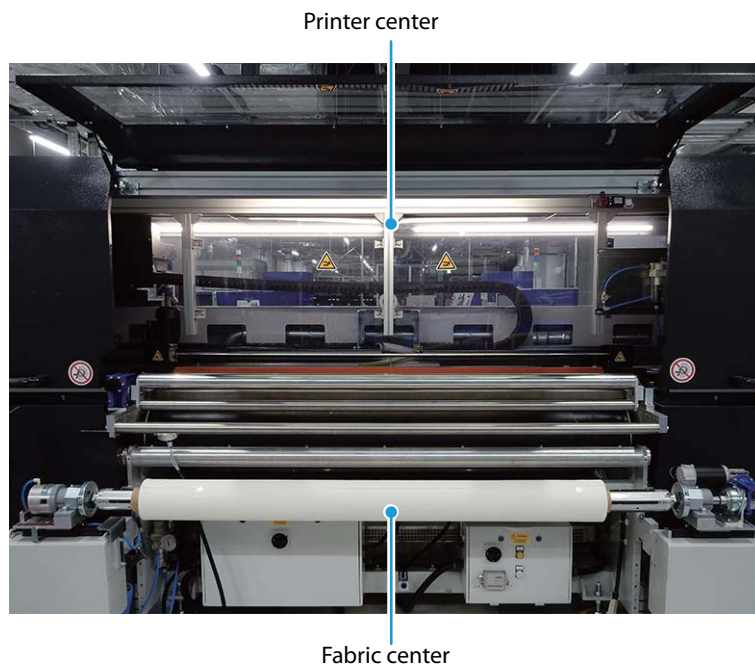

11 Insert the air expansion tool into the air inlet on the spindle and inject air. The stopper on the spindle swells to fix the fabric.

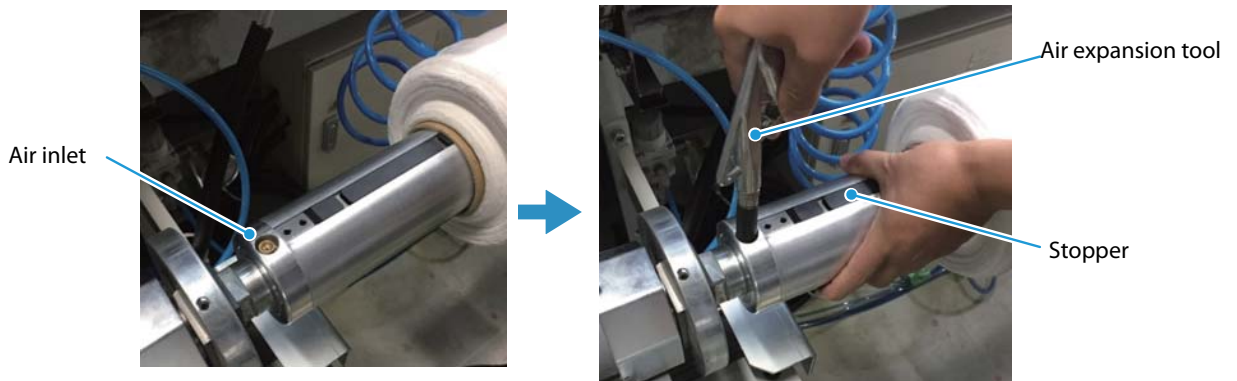

12 Feed the fabric through the roller as shown in the following image.



Cross-section of fabric path

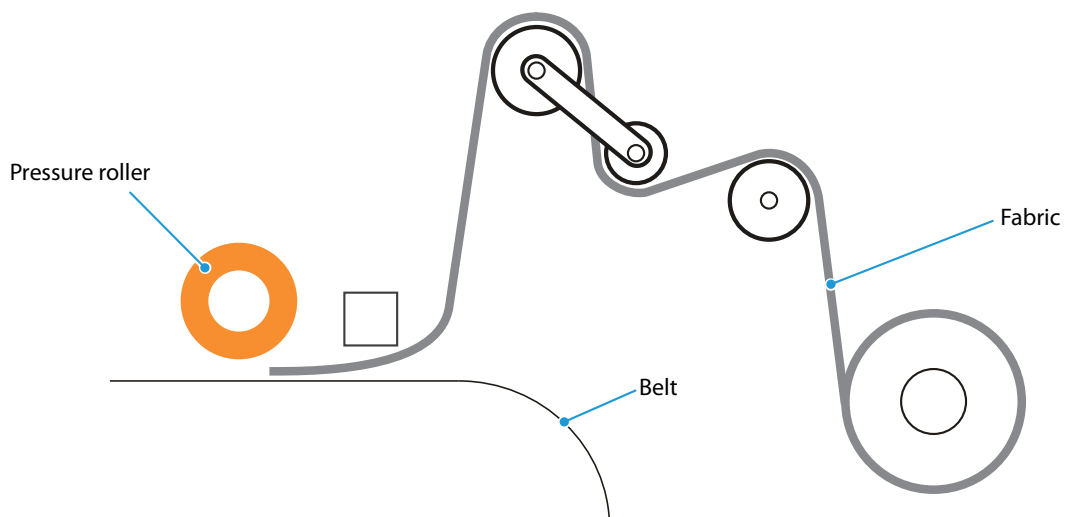

WARNING



Keep your hands away from the following moving parts while the machine is operating.

Otherwise, there is a risk of your hands, hair, or clothing becoming caught in the machine.

- Between the fabric guide bar and the fabric
- Fabric feeding belt
- Pressure roller

13 Affix the fabric to the belt.

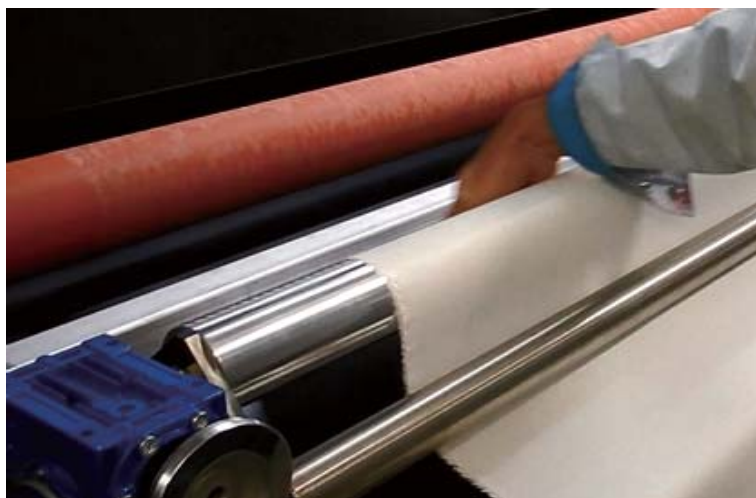

14 Press the belt feed button (forward) on the rear panel to feed the fabric to the edge of the pressure roller.

15 Turn the selection switch (black) to the left and lift up the pressure roller.

16 Turn the switch on the fabric tension adjustment panel to the right to lock the spindle. The spindle does not move even if the fabric is pulled.

17 Pull the fabric from the front of the pressure roller to remove any slack in the fabric on the left and right.



18 Turn the selection switch (black) to the left and lower the pressure roller.



WARNING

The descent speed of the pressure roller is slow, and it comes down gradually. However, be sufficiently careful not to place your hands or fingers under the roller.

19 Affix the fabric that was pulled from the top of the pressure roller to the belt.

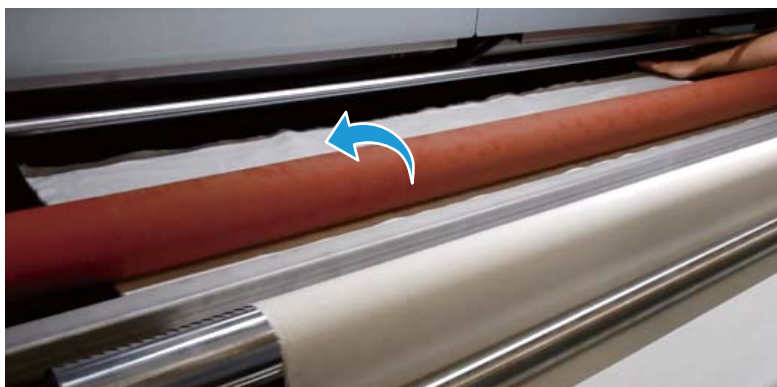

20 Close the rear protective covers.

21 Turn the pressure selection switch (black) to the right so that the fabric is affixed to the belt, without any areas where the fabric has lifted up. Move the pressure roller forward and back to affix the fabric to the belt.

This completes the work on the rear. Next, perform the work on the front.

22 Press the belt feed button (forward) to feed the fabric forward.



23 Install the fabric on the winder. Feed the fabric as necessary.



If there is enough length in the fabric edge, feed the fabric until the dryer and hold the fabric edge down with the roll core installed in advance on the take-up device or take-up unit. (If taking up, use adhesive tape.)

This completes the procedure for installing the fabric.

Slack Mode

Printing on knits and other fabrics that stretch and shrink can cause the fabric to be pulled and stretched. Use slack mode when printing on fabrics that stretch and shrink.



In the following cases, slack mode might not function correctly because the sensors fail to detect the slack part of the fabric when it sways from moving air.

- When moving air is generated around the machine due to exhaust from peripheral devices or the passage of people
- When printing on thin fabrics

Under such conditions, put a core into the slack of the fabric to prevent the fabric from swaying. Use a core that is heavy enough to prevent the fabric from stretching. If the core is too heavy, the fabric will stretch and wrinkle when printing.

1 Turn on the power at the electric box on the left rear side of the machine.



2 Press the button (blue lamp) on the rear panel. The button lights up.



- 3** Turn the slack detection switch to 1 (ON).
The switch lights up.



- 4** Turn switch ① on the fabric tension adjustment panel to the right to turn on fabric tension adjustment.

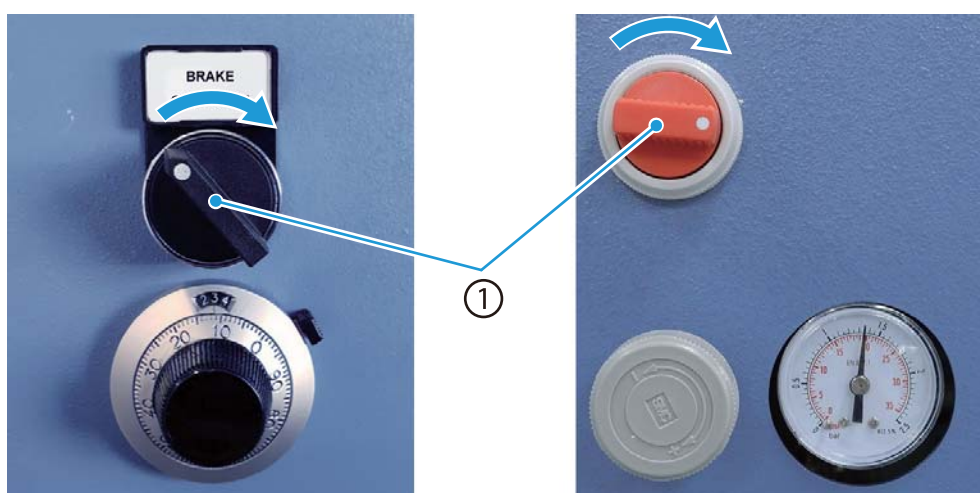

- 5** Load a fabric roll onto the feeding unit.
For more information, refer to ["Installing the Fabric" on page 90](#).

- 6** Turn dial ② on the fabric tension adjustment panel to the right, adjusting the fabric tension until the spindle does not rotate from the weight of the fabric roll and the fabric can be pulled out without resistance.

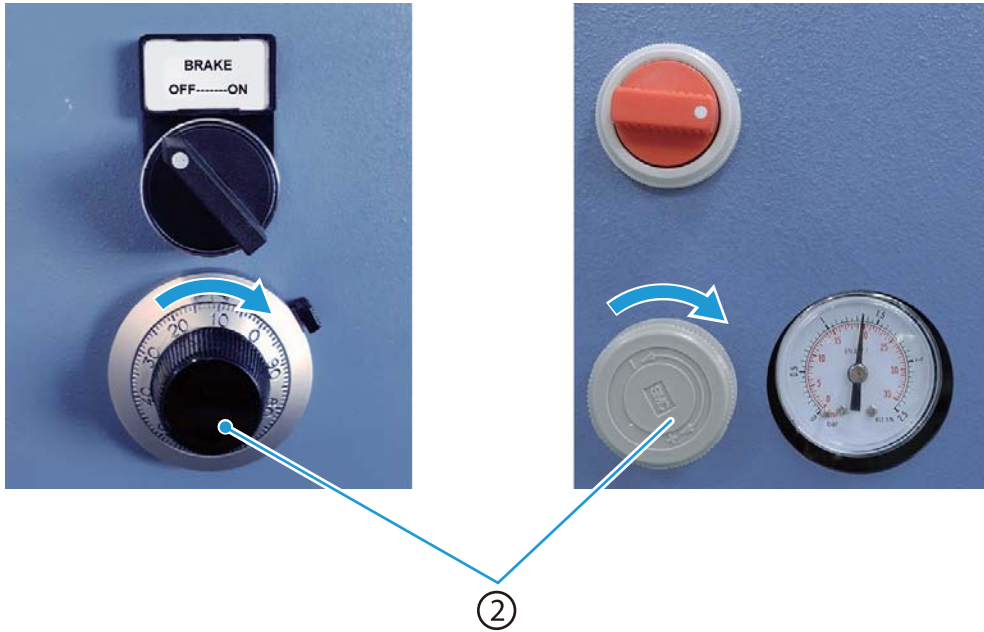

- 7** Put the core into the slack of the fabric.

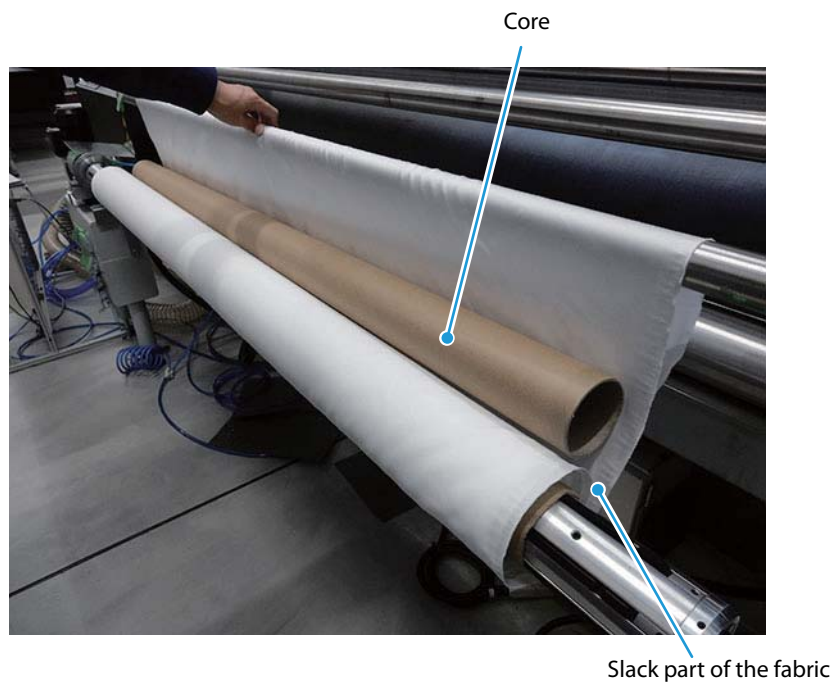

- 8** When printing on the inner side of the fabric, turn the slack adjustment switch to the left. When printing on the outer side of the fabric, turn the slack adjustment switch to the right.

The spindle for the feeding device will rotate and the fabric will begin to have slack.

The following procedures describe how to print on the inner side of the fabric.

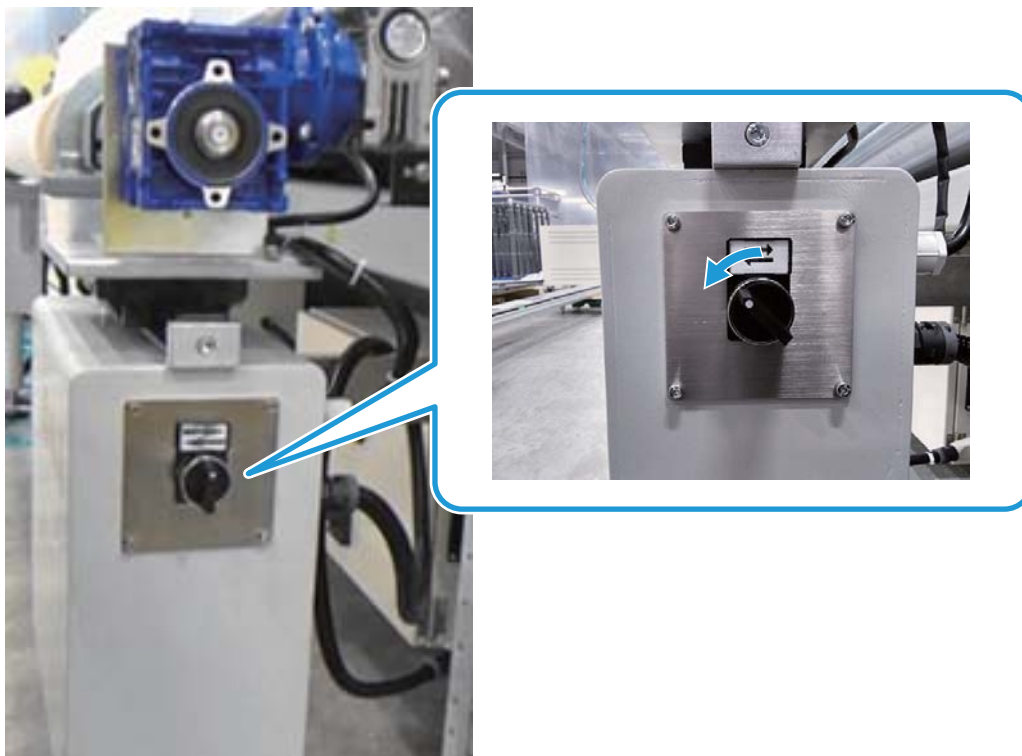

- 9** When the fabric hangs down to the height of the slack sensor, the machine automatically stops.

The amount of slack is detected by the slack sensor in the rear lower center. If the belt moves and lifts up the fabric causing there to be not enough slack, slack is given to the fabric until the sensor detects the fabric.

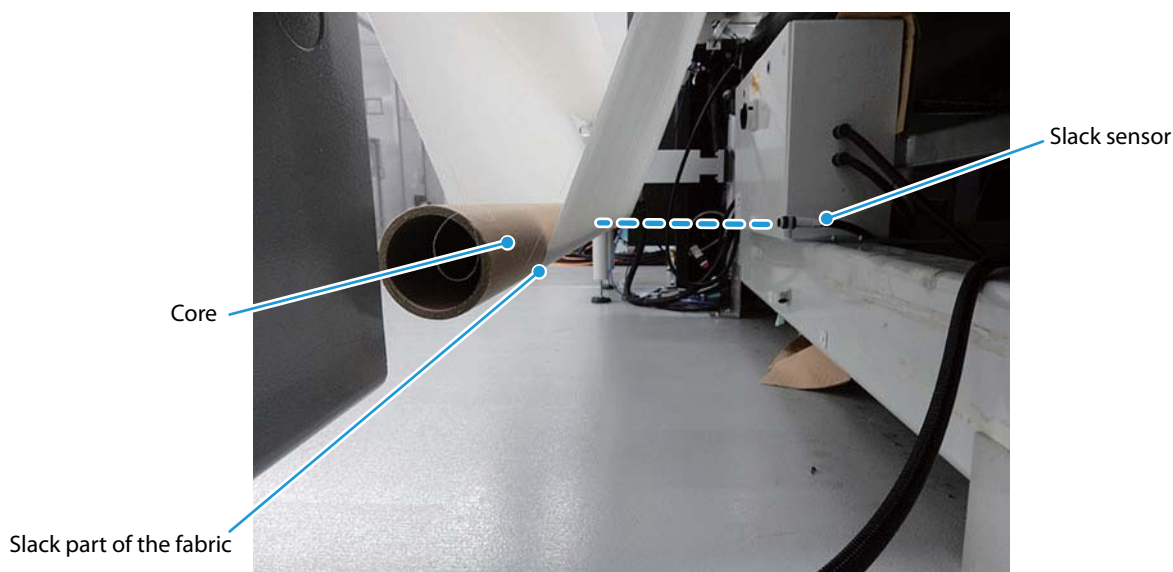

When the slack sensor does not detect the fabric

If the machine does not stop automatically even though the fabric hangs down to the height of the sensor, the fabric might be too far from or too close to the sensor. Adjust the distance between the sensor and the fabric.

1 Turn the slack adjustment switch to the center.

Slack mode stops.

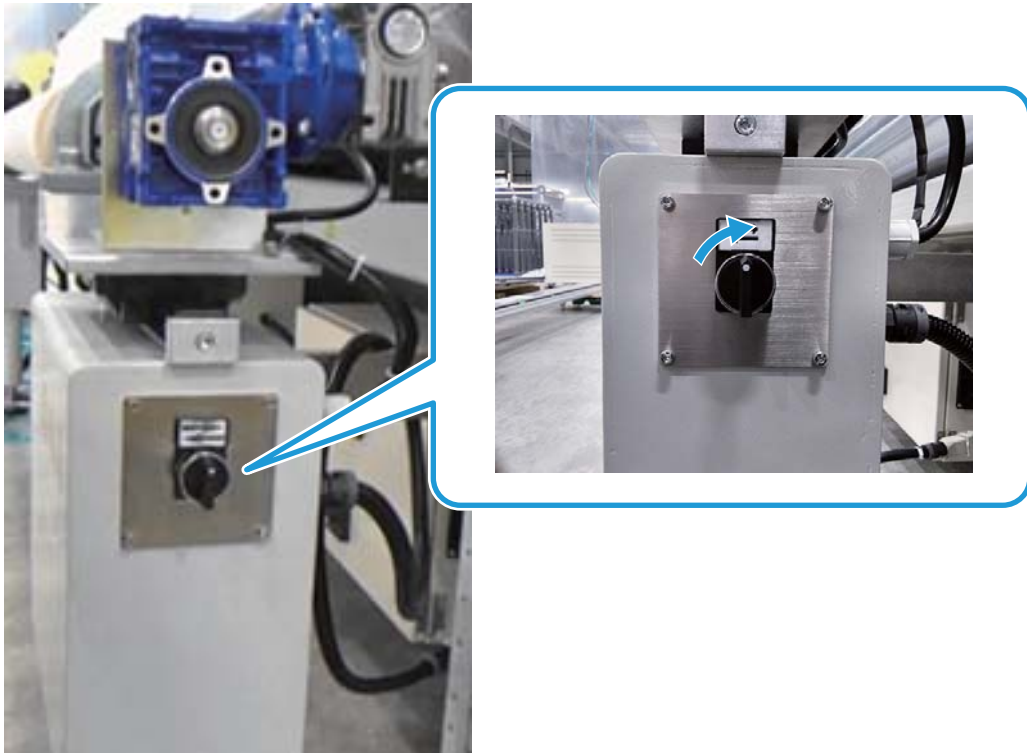

2 Loosen the two knob screws on the slack sensor.



- 3** Adjust the distance between the slack sensor and the fabric to between 50 and 150 mm {1.97 and 5.9 in}.



- 4** Tighten the two knob screws on the slack sensor.
- 5** Turn the slack adjustment switch to the left.
The spindle for the feeding device will rotate and the fabric will begin to have slack.

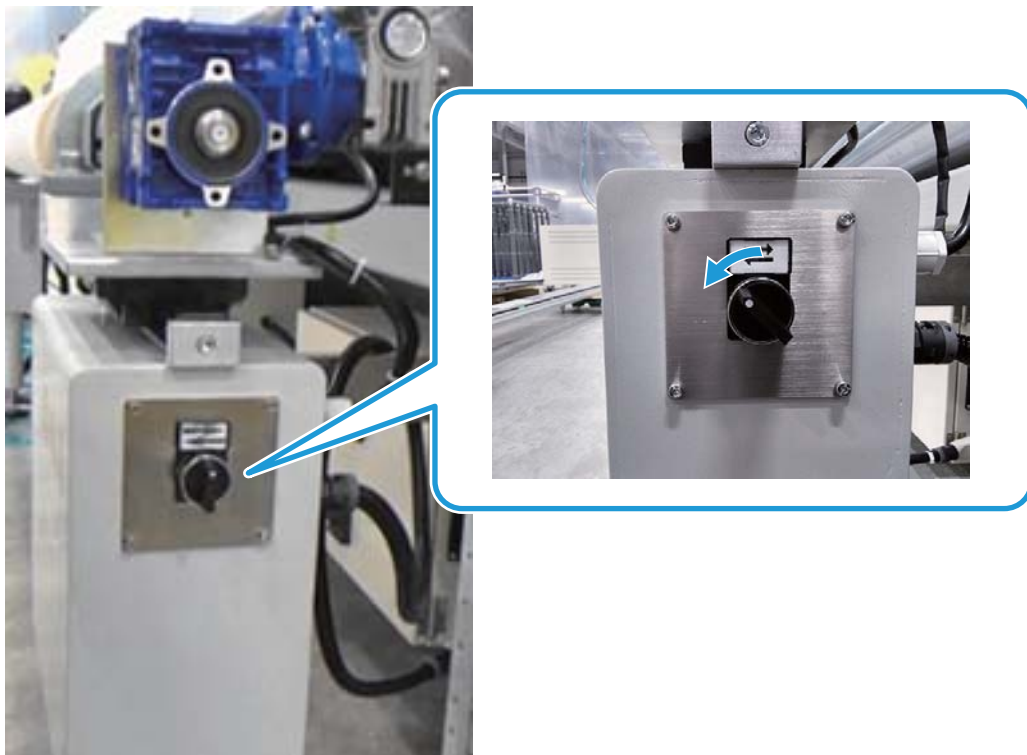

- 6** Confirm that the machine automatically stops when the fabric hangs down to the height of the slack sensor.

Fabric Meandering Correction

If you load a fabric roll with uneven edges, the fabric will meander. Either wind the fabric again or follow the procedures below. If the unevenness for edges of the fabric is severe, wind the fabric again.

- 1 Turn on the power at the electric box on the left rear side of the machine.

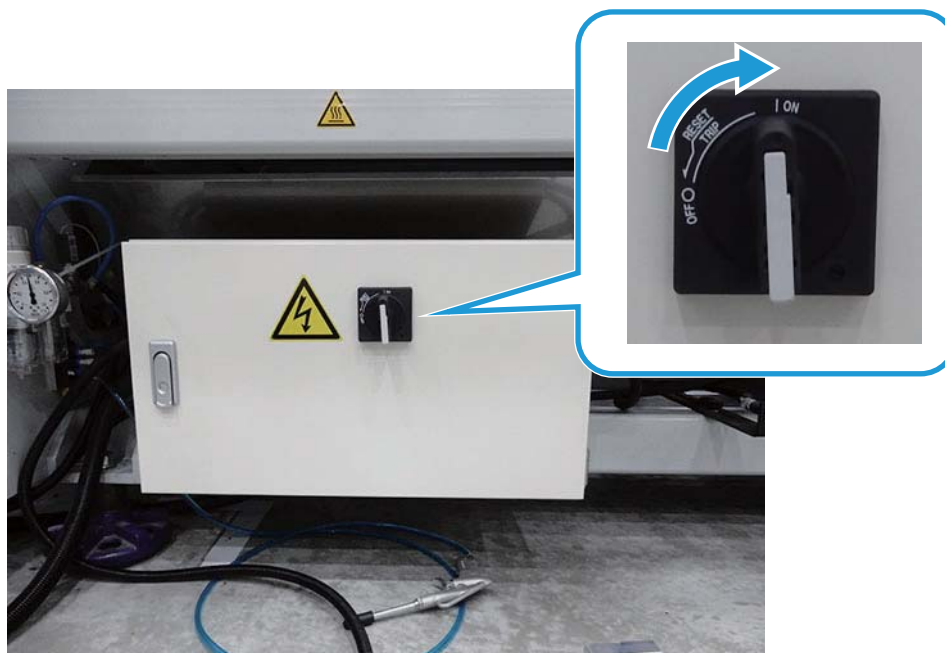

- 2 Press the button (blue lamp) on the rear panel.
The button lights up.



- 3** Turn the selection switch on the rear panel to MAN.



- 4** Use the selection switch to set the memory of the feeding unit to 0.
Turn the selection switch to SX to move the fabric spindle to the left, and to DX to move it to the right.

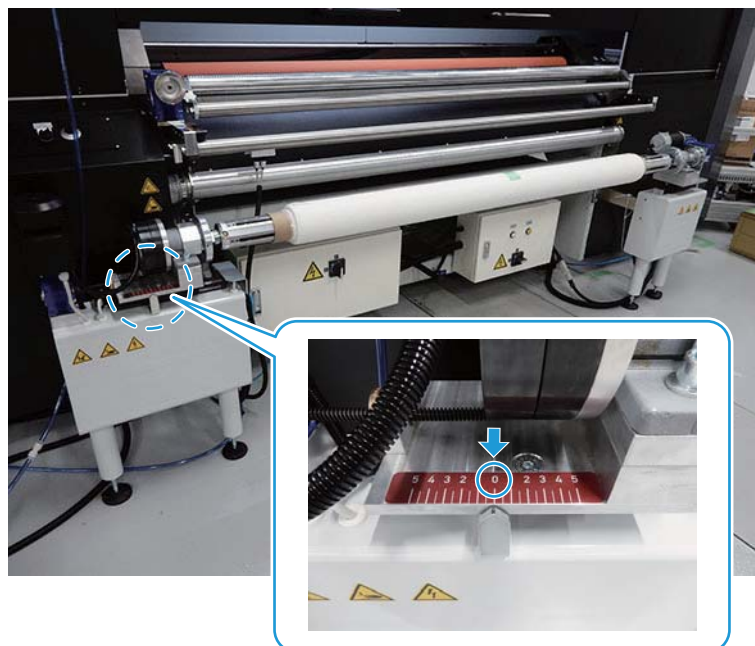

5 Adjust the position of the fabric edge sensor unit so that the left edge of the fabric is centered between the two sensors.

Loosen the knob screw to move the fabric edge sensor unit to the left or right. Align the fabric edge sensor unit with the left edge of the fabric, and then tighten the knob screw to secure it.

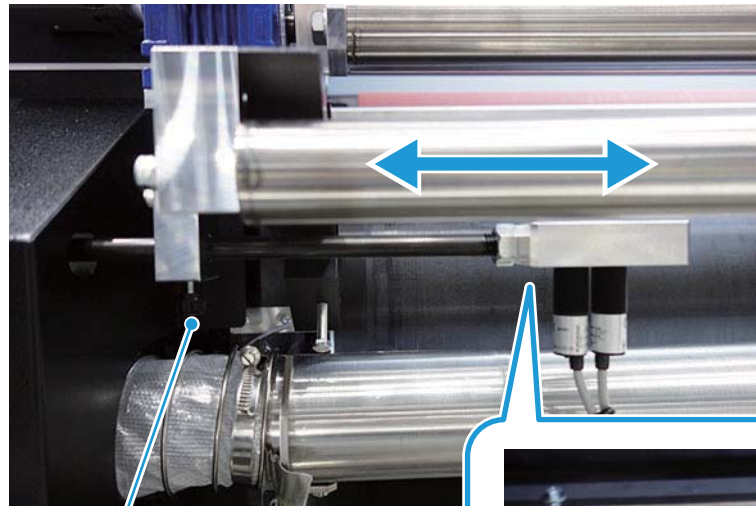

Knob screw

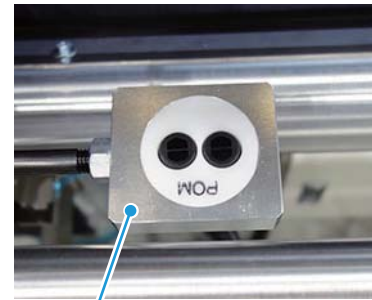

Fabric edge sensor unit

Left edge of the fabric

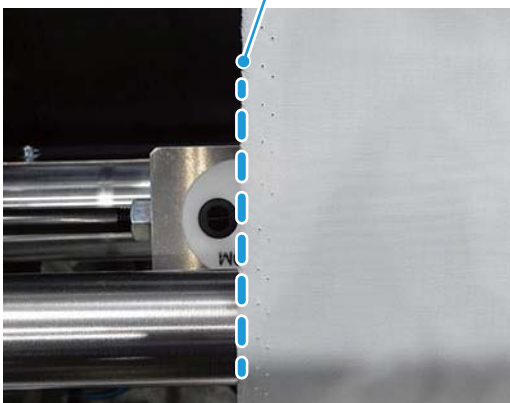

- 6 Turn the selection switch on the rear panel to AUTO.**
The meandering of the fabric is automatically adjusted when printing starts.



Precise correction of meandering fabric

Use the following procedures to more precisely correct meandering fabric.

- 1 Use a hex wrench (2.5 mm {0.1 in}) to loosen the sensor adjustment screw.**

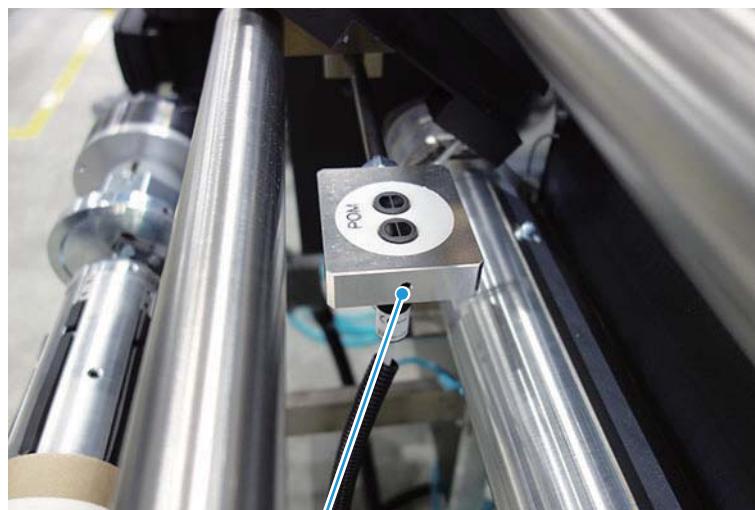

Sensor adjustment screw

2 Rotate the fabric edge sensors to the right to make the detection range more narrow.



Do not rotate the sensors more than 90° to the right. Otherwise, the sensors will be switched left to right, and it will not be possible to correct meandering.

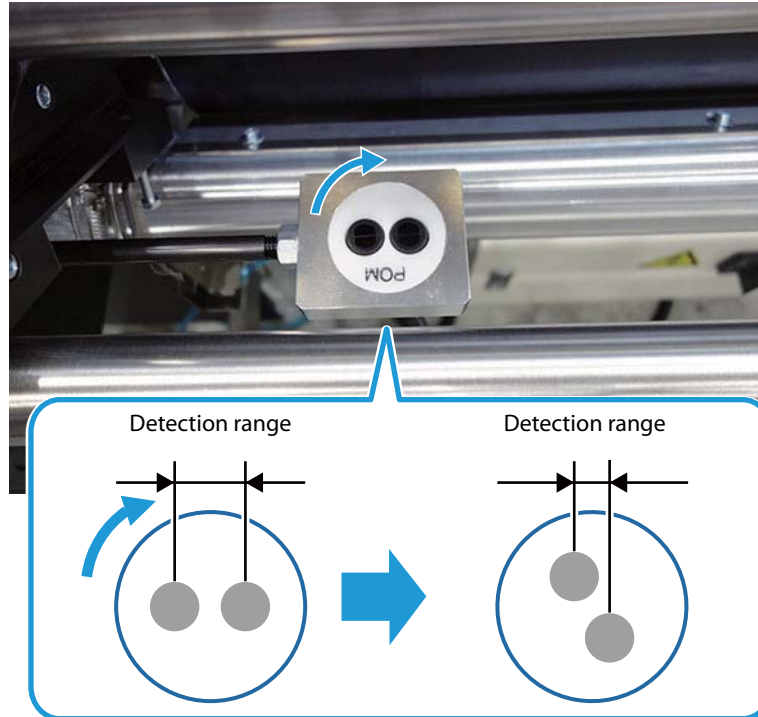

3 Use a hex wrench (2.5 mm {0.1 in}) to tighten the sensor adjustment screw.

To return the sensors to the original detection range, rotate the fabric edge detection sensors to the left.



Do not rotate the sensors to the right. Otherwise, the sensors will be switched left to right, and it will not be possible to correct meandering.

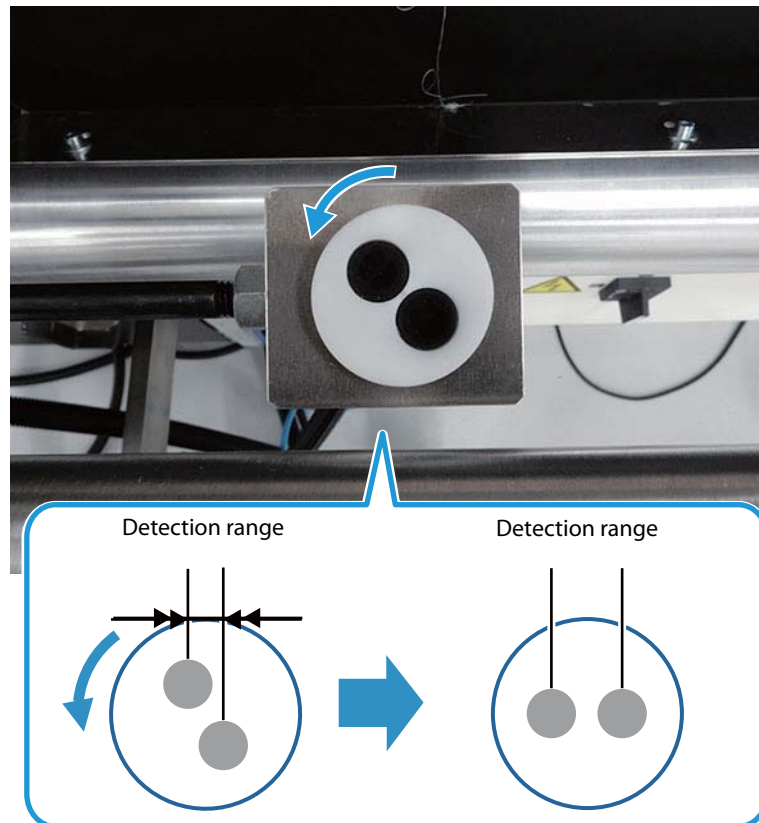

Set the Foreign Material Detection Sensor

Set the foreign material detection sensor. When loading the fabric for the first time or changing the fabric type or thickness, you need to set the sensor.

Located at the side of the belt, this measures gaps on the upper side of the fabric with a laser beam. If there is foreign material on the fabric or if the fabric floats upward without pressing against the belt, generating a value that is below the threshold value, printing is stopped to prevent the print head from colliding with the foreign material or fabric. This threshold value is set by the user.

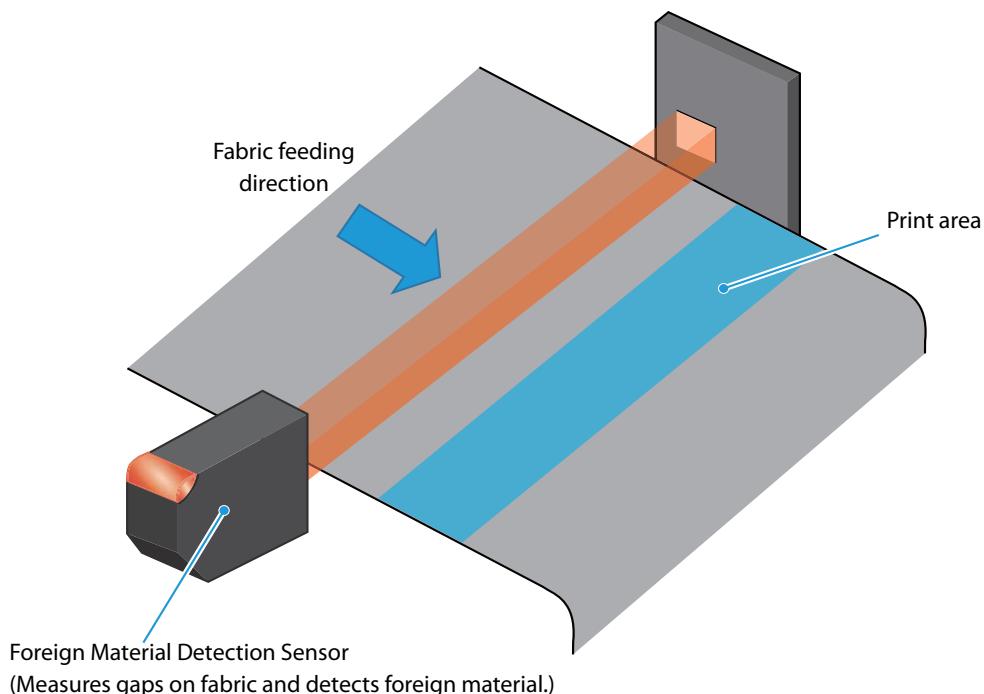
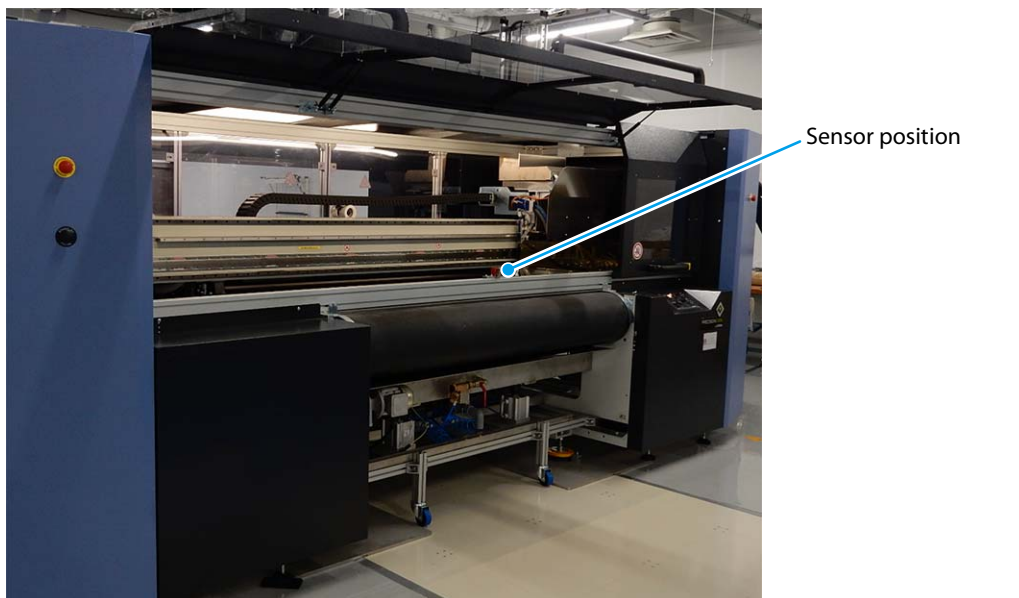

	<p>CAUTION To prevent print head damage, set appropriately.</p>
	<p>Sensors are located on the left and right sides of the print head carriage. When foreign material is detected, the machine stops.</p>

How to Set the Foreign Material Detection Sensor

Set according to the following procedure.



- 1 Turn the selection switch (white lamp) on the front panel to ON.



CAUTION

Normally, leave the selection switch (white lamp) ON to enable the foreign material detection sensor. If this function is disabled, a collision with foreign material on the fabric may cause a head failure. Head failures due to collisions are not covered by the warranty, even during the product warranty period.

- 2 Open the cover on the display.

(3) Fabric is not set.

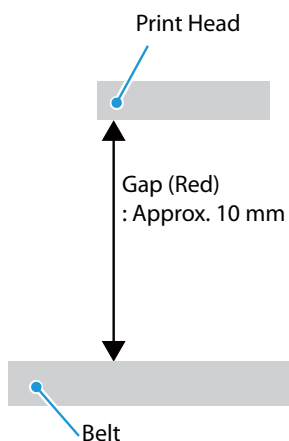

- Counter values
- Red: 9999
 - Green: -

(4) Fabric is set.

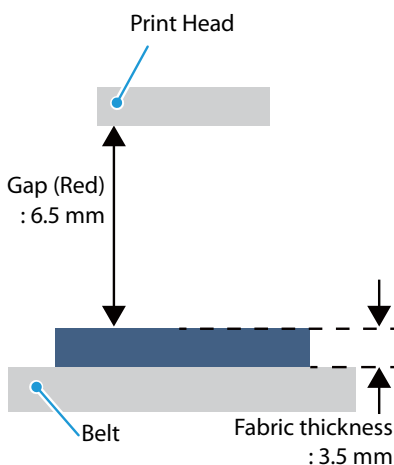

- Counter values
- Red: 6500
 - Green: -

(5) Threshold value setting

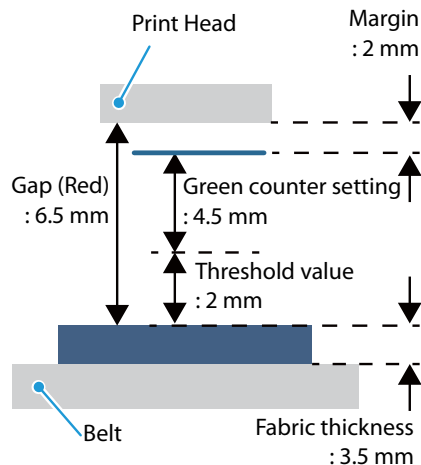

- Counter values
- Red: 6500
 - Green: 4500

- 3** If the fabric is not set, the red counter will show 9999. This shows there is a gap of about 10 mm. Values may vary depending on the condition of the belt.
If the fabric is set, the red counter displays the gap between the print head and fabric.

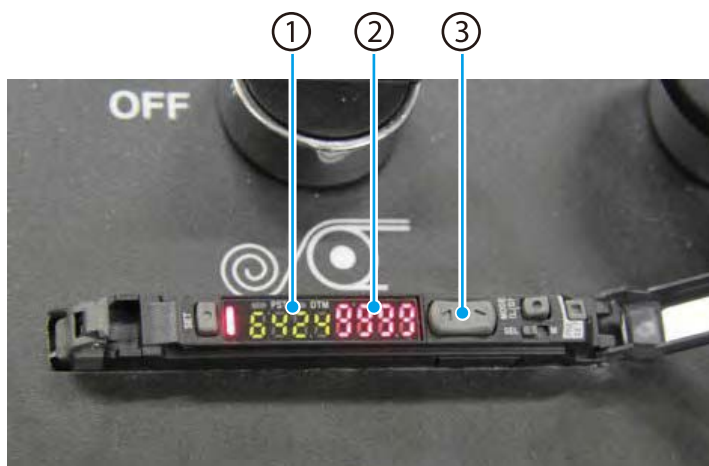

No.	Name	Description
1	Green counter	This is the setting for the threshold value. If detected value falls below this number, an error occurs and printing stops.
2	Red counter	Displays the height of the fabric, measured with a laser.
3	Selector	Use the selector to set the height. Press + to increase the value for the green counter, and press - to decrease the value.

- 4** Press the + or - of the selector to set the threshold value. The value is displayed by the green counter. The difference between the red counter and green counter is the threshold value.

	<p>Recommended setting: Set a value that is 2000 less than the red counter.</p> <p>Setting example: If the red counter is set to 4500, set the green counter to 2500.</p>
---	---

- 5** Close the display cover.

Set the Printer

Configure the settings in the Print menu.

Set the Fabric Thickness and Head Height

Set the fabric thickness and head height according to the fabric that is used.



Fabric Thickness

Since ink is discharged while the print head moves at high speed, the ink dot position will change according to the distance from the print head to fabric surface.

With bidirectional printing, the ink lands at the height position set with Fabric thickness. If this height is not correct, the inkdot position will differ depending on whether printing is from the left or right, causing print quality to drop. Therefore, it is extremely important to ensure that the Fabric thickness setting matches the fabric thickness.

The figures below show the ink dot positions when the Fabric thickness is incorrect versus when it is correct. When the Fabric thickness is correct, the ink dot positions will be uniform, resulting in high-quality printing.

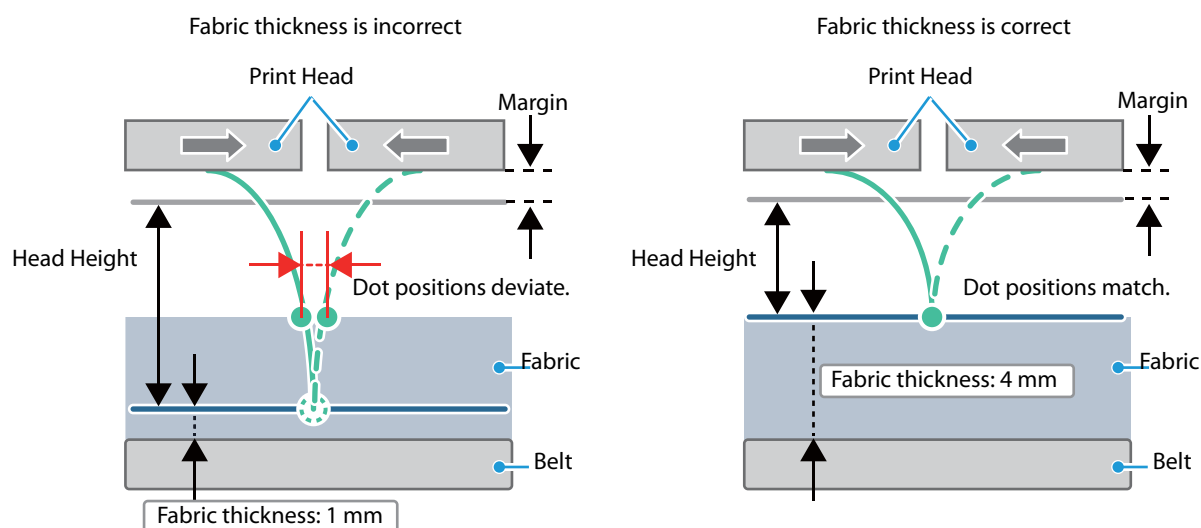

Head Height

This setting adds the distance from the print head to the belt. Use it to set a safe distance from the fabric surface so that the print head will be protected.

Set it to protect the print head from fluff generated from the fabric and from fabric edge (ear) processing.

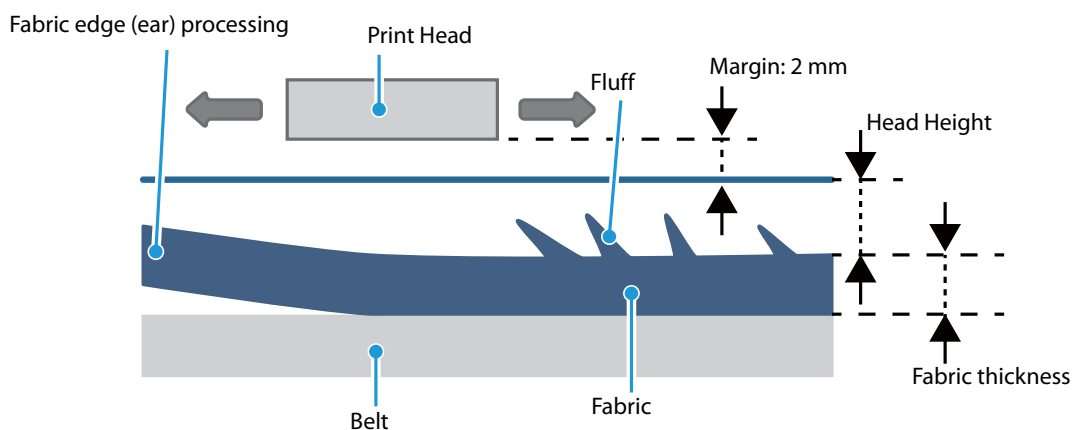

Up to 10 mm can be set in total for Fabric thickness and Head height.

Giving a 2 mm margin to this value, the print head height is a maximum of 12 mm.

Recommended Head height setting:

- High quality: 0.7 mm
- Stable operation: 2.0 mm



- Appropriate values for Head height will vary according to the type of fabric used.
- If the Head height setting is large, the gap between the print head and fabric surface will be large, possibly generating ink mist. For optimal adjustment, we recommend that you take the fabric type and thickness into account.
- Manufacturer declines any responsibilities if the operator does not respect all the necessary precautions to keep safe the main printing components also during these operations.

Set the Printer Equipment and Sensors

Set the printer.

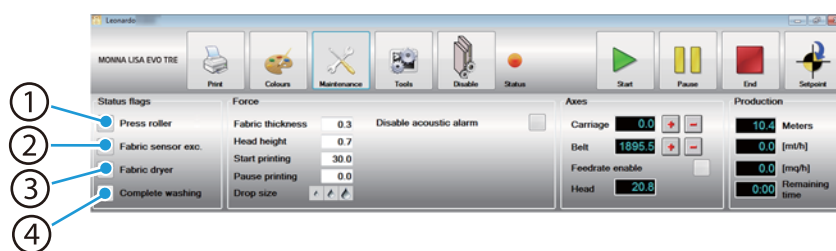

No.	Name	Description
1	Press roller	Select this flag to operate the press roller. This flag is selected automatically when printing is in progress.
2	Fabric sensor exc.	Unselect this flag to operate the foreign material detection sensor. This flag is unselected automatically when printing is in progress. This is enabled only when the selection switch (white lamp) on the front panel is ON. (Page 59)
3	Fabric dryer	Select this flag to operate the belt heater. This flag is selected automatically when printing is in progress.
4	Washing	Select this flag to operate the belt cleaning system.



CAUTION

If the printer is stopped for a long period of time, disable the belt cleaning system and dryer. Otherwise, the heating process and drying process could damage the belt and cause the glue on the belt to become too dry.

Load the Print Data



To load print data into Leonardo, first copy the job files to a user-defined folder on the control PC. We recommend creating a folder named "Design" or something similar on the desktop of the control PC. To load job files from USB memory, connect the USB device to the USB port on the back of the display. To remove the USB memory from the control PC, perform the correct Windows operation to safely remove hardware.

1 Click [Load file] in the Print menu.



2 Follow the on-screen instructions to select a job file.

The information for the file that is loaded is displayed in the [Print] menu.

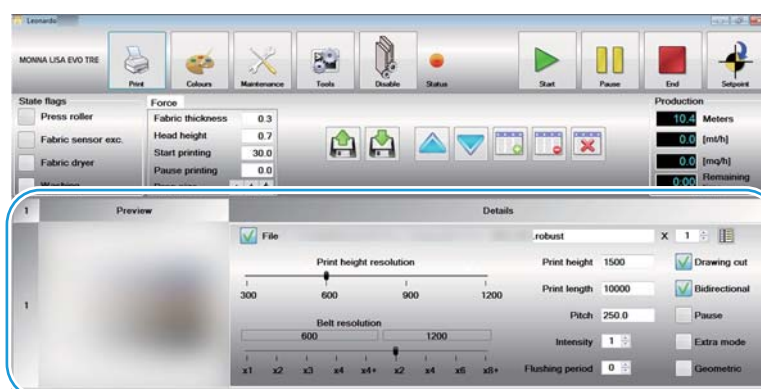
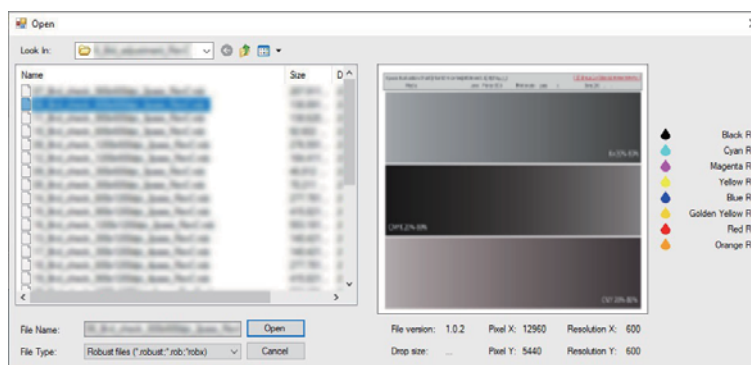

There is a character limit for file names.

When adding data, if the message is displayed but the file information is not displayed, reduce the number of characters in the file name, including the path, displayed for [File name] on the [Load file] screen. When using ASCII characters, limit the input to 251 characters.

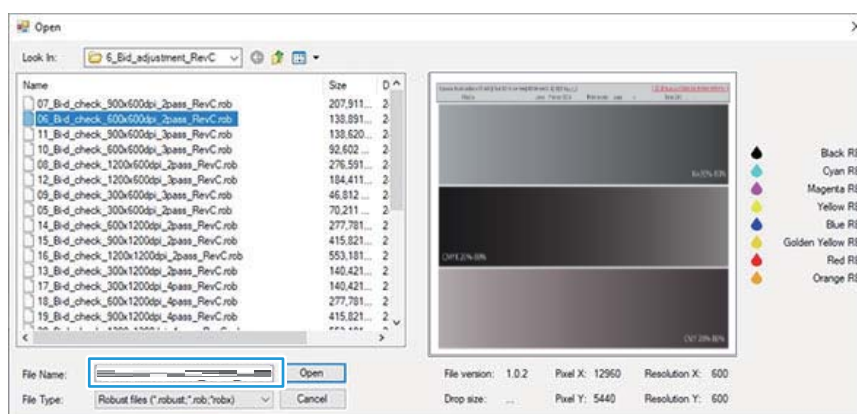

Some types of ROB file creation software may automatically generate a design file for color patches at the same time as the ROB file.

If there is a design file for color patches in the same folder as the ROB file and the design file for color patches has the same file name as the ROB file (ROBfilename_chips.rob), the design file for color patches is loaded at the same time the ROB file is loaded.

3 To load multiple job files, repeat steps 1 and 2.

Set the Print Data

Check the job file, and configure the settings if necessary.

Only the settings to be configured for printing are described here. For more information about job files, refer to the Appendix.



The resolution is set with ROB file creation software (EpsonEdgePrint Textile, Wasatch) when the job file is created, and therefore cannot be set here. To change the resolution, create the job file again.

1 Set the number of passes. Use the slider on one of the bars to select a value.

Vertical resolution of 600 dpi: Left bar

Vertical resolution of 1,200 dpi: Right bar



2 Specify the printing direction for the print heads. Select [Bidirectional] for bidirectional printing.



- 3** Extra mode uses twice the amount of ink as Normal mode. Select [Extra mode] to print in this mode.



Selecting Extra mode causes the print speed to drop.

Printing

Checking the Status of the Fabric

Check the status of the fabric.

- The fabric must be pulled into the print surface and spread out flatly.
- There must not be any folds or protrusions and the fabric must not be lifted up.
- If there is a seam between pieces of fabric, take measures to make it flat so that it does not scrape against the head.

Checking the Print Path

Check the print path.

- No foreign material in the print head operating area.
- There must not be any abnormalities in the fabric path or winding path.

Checking the Ink

Before printing, lift the ink cartridges in the ink rack by hand to check if they contain sufficient ink.

Configuring the Print Settings

Set the print length and the margin (right side) for when printing starts.



Item	Description
Start printing	Set the margin from the right edge. (mm)
Pause printing	Set the length from when printing starts until it stops. (m)

Check the length of the fabric to be printed on, and then enter a value at least 3 m shorter than the actual fabric length.

**WARNING**

For the following reasons, perform settings so that printing ends with 3 m or more of fabric left.

- If the ending edge of the fabric is not affixed to the core, the fabric can slip off the core, meaning it is not held by the brake or tension device and cannot properly adhere to the belt. If printing continues in that state, the fabric can become caught on the head and damage the head.
- If the ending edge of the fabric is affixed to the core, the belt is pulled by the piece at the end of the fabric, putting excessive strain on the belt motor. This could cause belt motor malfunctions.

**CAUTION**

We recommend always using the Pause printing option.

Using this option lets you set the length (meters) to be printed. When printing stops, the machine pauses and waits for the next command.



A test print should be at least 1 m, to check for banding due to misalignment of the print heads.

Print**1** Click the [Start] button.**2** If the "Enable belt cleaning" message is displayed, click [YES].**3** The print cycle starts. The printed fabric is fed to the belt on the take-up side of the machine front.

If there are any print quality problems, refer to ["Print Quality" on page 147](#).

Checking the Cleaning Unit

Confirm that water is provided to the cleaning unit and check the water level in the tank.

Printing Ends

After it finishes printing the set length, the printer stops in PAUSE mode.

After the printer stops, the operator can remove the fabric from the core that finished printing, then handle any issues such as folds in the fabric edge by hand.

Stopping Printing

When printing of the job files that were set when printing started is complete, the machine stops automatically. To stop printing before printing is complete, click [End] in Leonardo.



Replace the Ink

Checking the Amount of Ink

Use the [Colours] menu in Leonardo to check the amount of ink in the ink system.

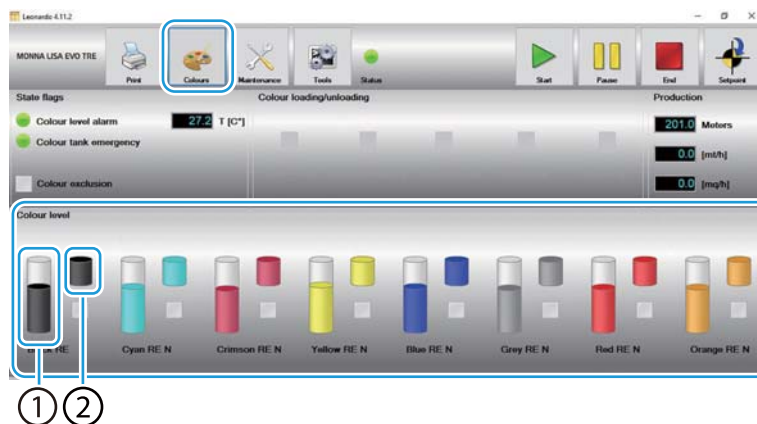

No.	Name	Description
1	Main tank	Allows you to check the approximate amount of ink remaining in the ink cartridge.
2	Sub-tank	Allows you to check the approximate amount of ink remaining in the sub-tank.

Replace the Ink (3L)

The buzzer sounds when low ink is detected in this machine.

Use the following procedure to replace ink.



Replace the ink within one minute after low ink is detected.

Continuing to print after ink low is detected without replacing ink will cause printing to stop when the sub-tank rack is empty.

- 1 In the [Colours] menu in Leonardo, check the number of the ink cartridge in which the ink is low.**

Example: "Colour tank 4 empty" (The number is the ink cartridge number)

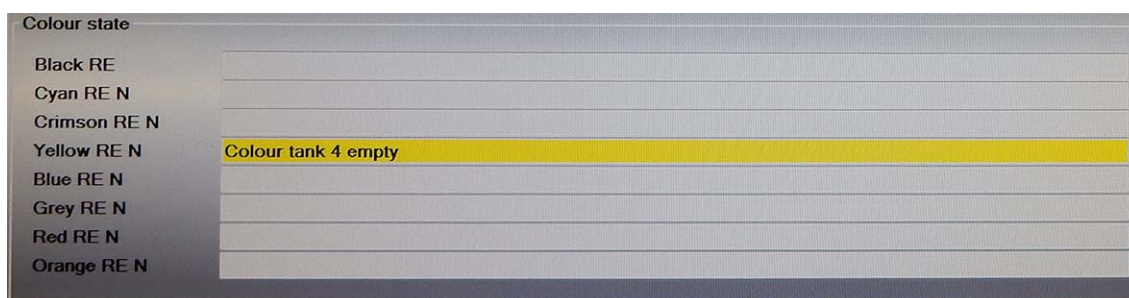



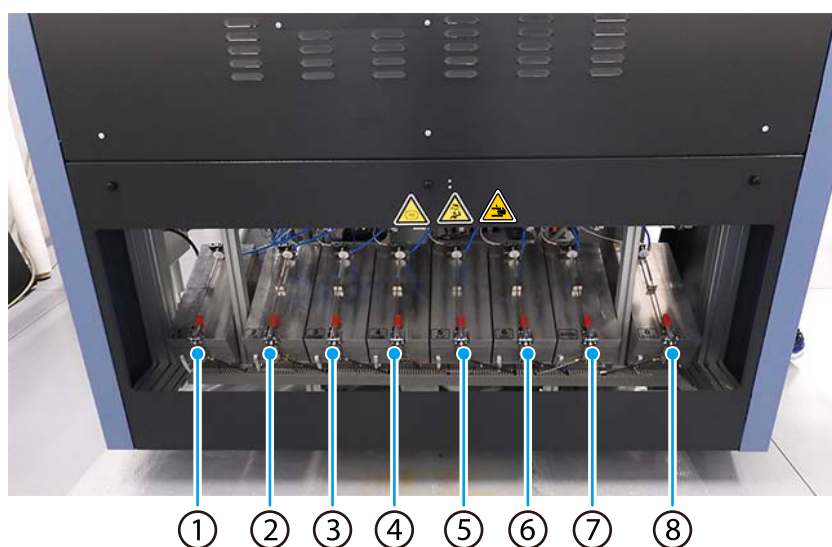

Ink cartridge numbers

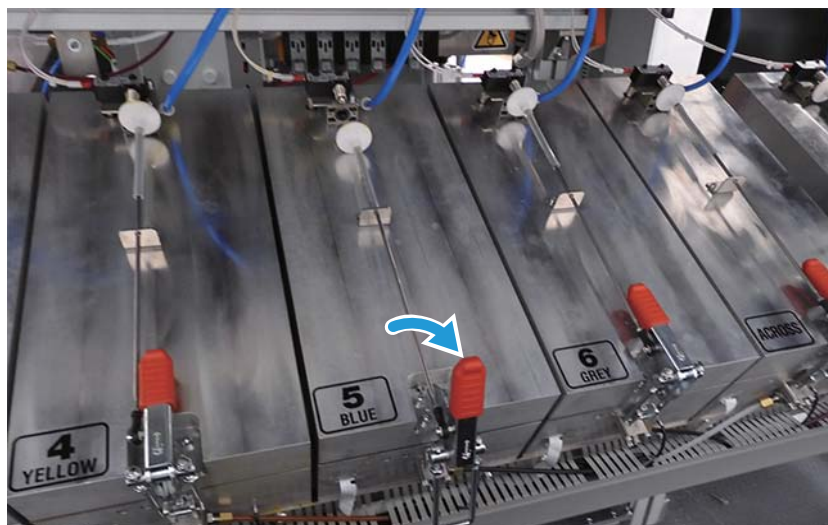

- 2 Pull the tank opening/closing handle on the ink tank that contains the ink cartridge to be replaced.



- 3 Lift the ink tank cover carefully (1) and hook the tank opening/closing handle onto the cover support hook (2).

 CAUTION	
	<p>Make sure that the tank opening/closing handle is hooked on the cover support. If the ink tank cover closes, your hand could be caught in the machine and get injured.</p>
	<p>Open the ink tank cover gradually and with care. The ink tank interior is under pressure. When the cover is opened, the released pressure could injure your hand.</p>
	<p>Be careful not to hit your head on the upper area of the ink rack. Failure to do so could lead to injury.</p>

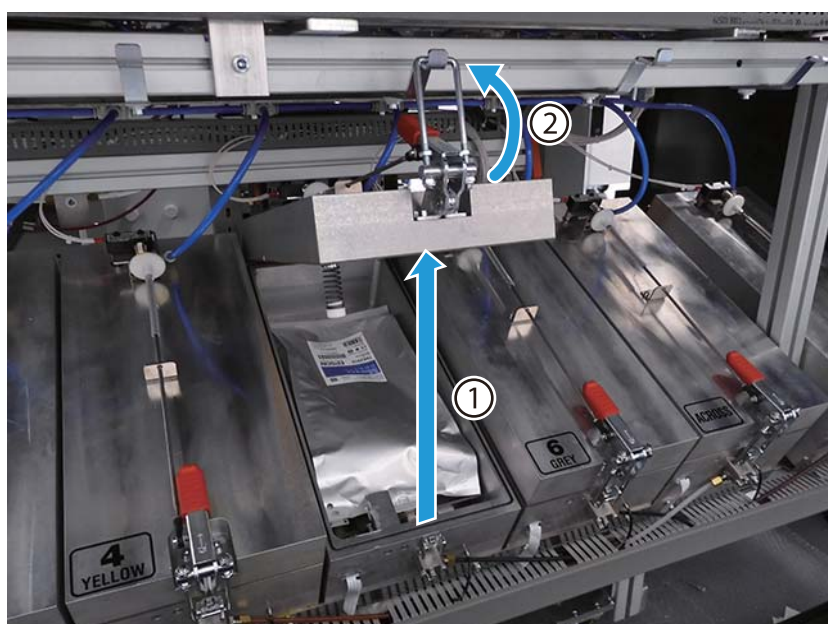

- 4** While pushing the cartridge carriage upward (1), turn the lever to the left (2). Then, the ink cartridge supply port is disconnected from the ink tank needle and the cartridge carriage is secured.



- 5** Push up the IC chip on the ink cartridge to remove it from the reader and remove the used ink cartridge.



- 6** Shake a new ink cartridge to stir the ink.

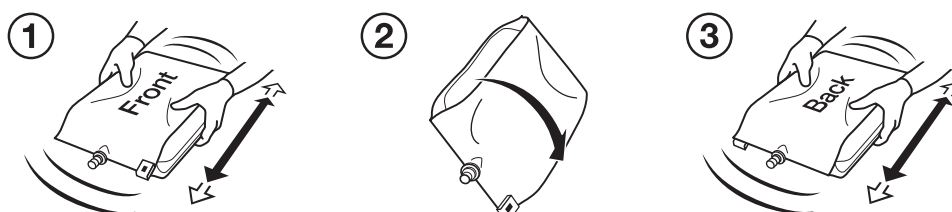

- 7 Set the new ink cartridge on the cartridge carriage with the its label facing upward.
- 8 Set the depressed part of the ink cartridge supply port into the supply port securing section (cutout). Set the port in the correct position as shown in the figure below.

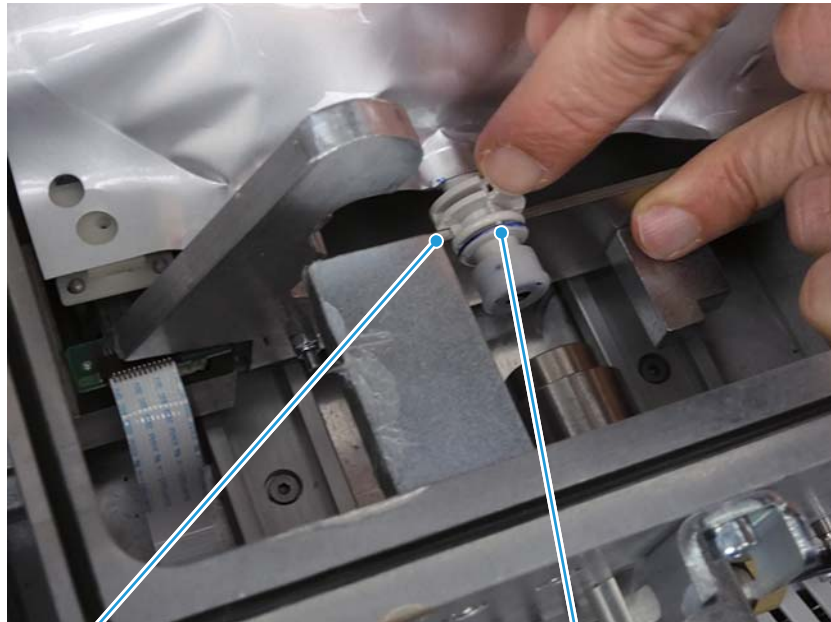

Supply port securing section

Ink cartridge supply port

OK

Pattern A

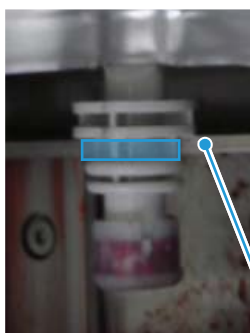

Cutout on supply port
securing section



Pattern B



Cutout on supply port
securing section



Pattern C

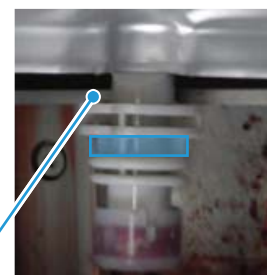

Depressed part of ink
cartridge supply port



CAUTION

- Pattern B may cause ink leaks due to the ink cartridge supply port being insufficiently inserted.
- Pattern C may damage the ink cartridge supply port or needle.

- 9** While pressing on the cartridge carriage with your right hand, turn the lever to the right and set the lever above the ink cartridge supply port.



- 10** Move the cartridge carriage slowly toward you. The needle is inserted into the ink cartridge supply port and the ink cartridge is set in place.

11 Connect the IC chip on the ink cartridge to the reader. Attach the holes on the IC chip onto the pins on the reader.



If the IC chip is not connected correctly, the ink cartridge is not recognized on the machine.

OK

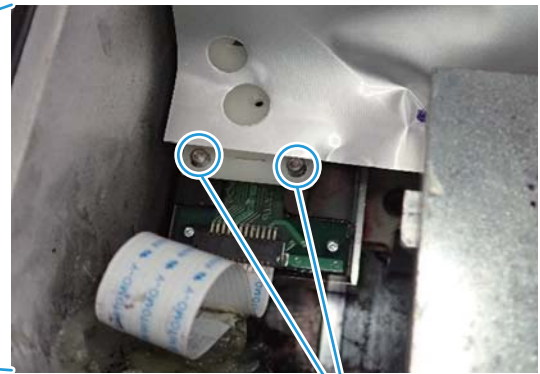
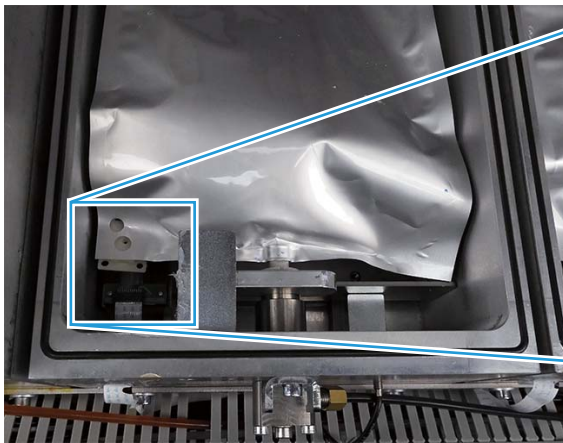

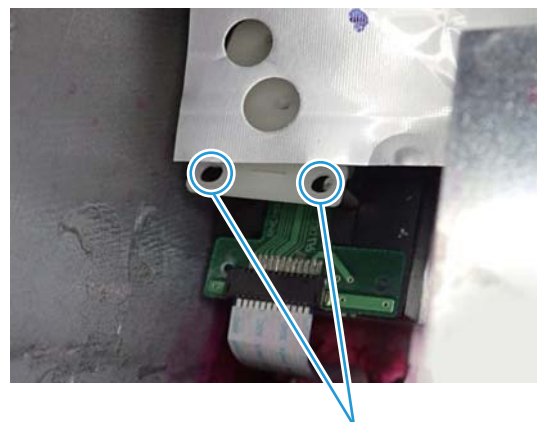

The pins are inserted in the holes on the IC chip.



The pins are not inserted in the holes on the IC chip.

- 12** Unhook the tank opening/closing handle from the cover support hook (1), and close the ink tank cover (2).

 CAUTION	
	If the ink tank cover closes, your hand could be caught in the machine and get injured. Make sure that the tank opening/closing handle is hooked on the cover support hook.
	Your head may hit the upper area of the ink rack during replacement work. Pay careful attention while working.

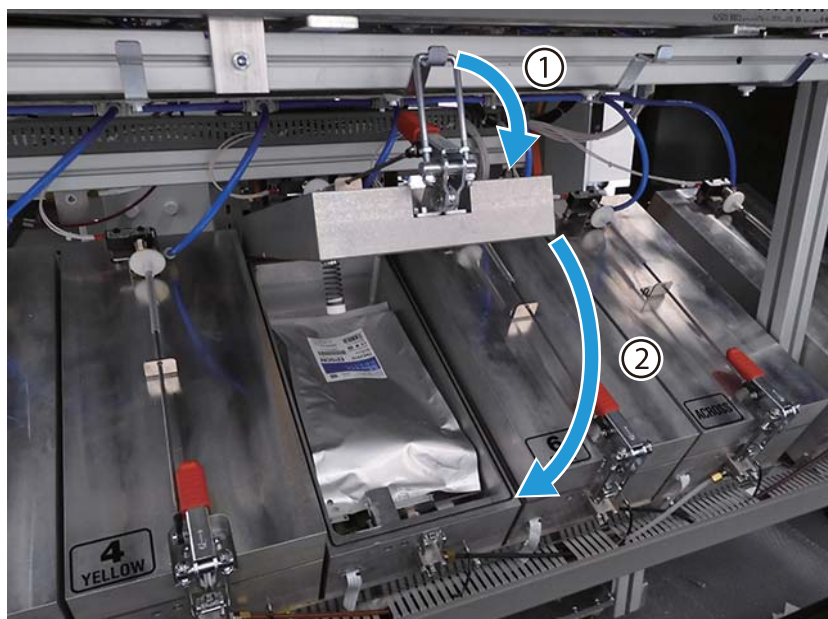

- 13** Push the tank opening/closing handle downward and lock the ink tank cover.

Use the [Colours] menu in Leonardo to check that the ink status has changed.

Replace the Ink (10L)

The buzzer sounds when low ink is detected in this machine.
Use the following procedure to replace ink.



Replace the ink within five minutes after low ink is detected.
Continuing to print after ink low is detected without replacing ink will cause printing to stop when the sub-tank rack is empty.

- 1** In the [Colours] menu in Leonardo, check the number of the ink cartridge in which the ink is low.

Example: "Colour tank 4 empty" (The number in quotes is the ink cartridge number)

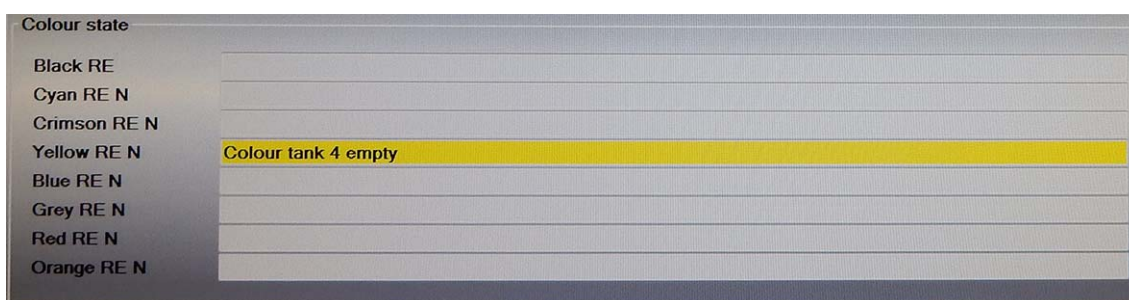

Ink cartridge numbers

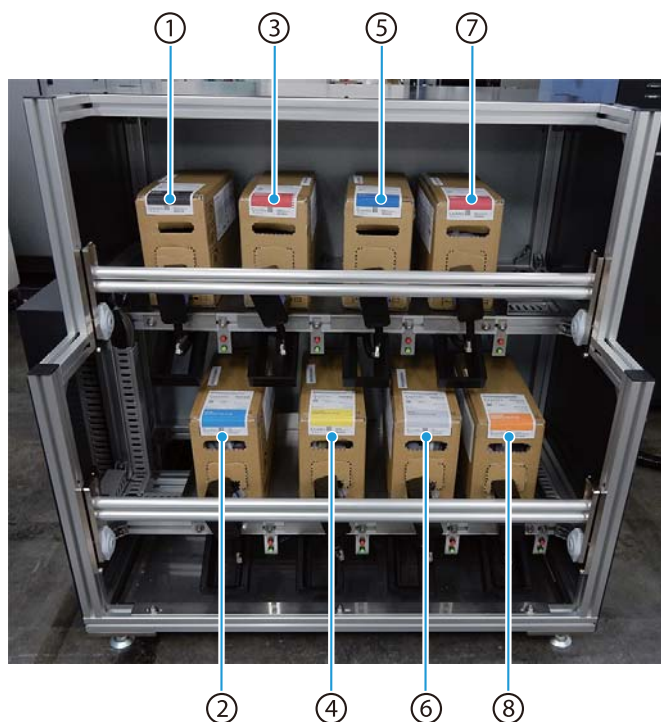

- 2 Double-click the ● icon for "Colour level alarm". The buzzer stops, and the ● icon changes from yellow to green.

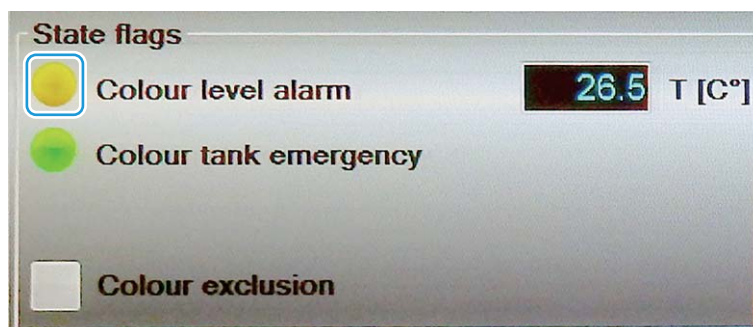

- 3 Check on the ink rack if the red LED of the corresponding ink cartridge is lit up.

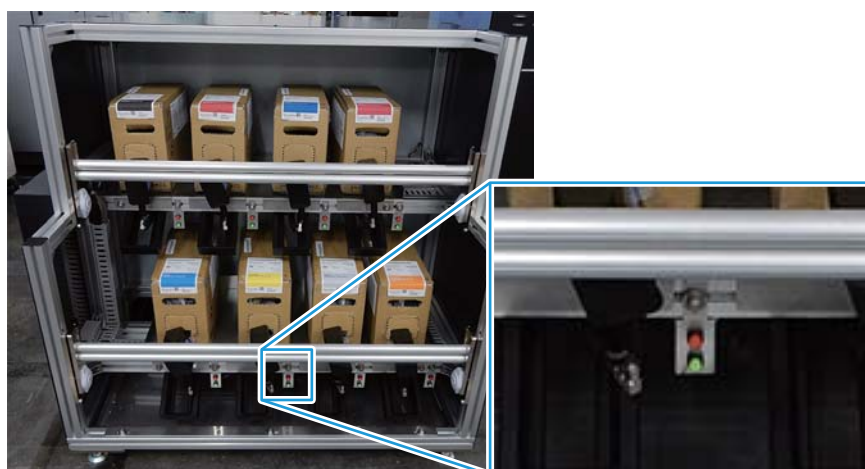

- 4 Prepare a new ink cartridge, and stir the ink. As shown in the figure below, (1.) place the cartridge with its widest surface facing upward and rotate it five times and then (2.) turn the cartridge over and rotate it another five times.

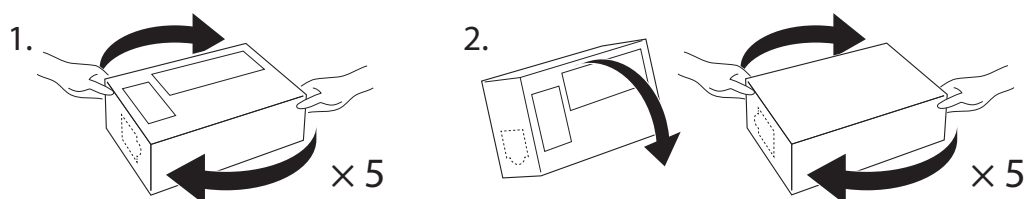

- 5** Place the ink cartridge as shown in the following image.



- 6** As shown in the figure on the ink cartridge, cut along the dotted lines by hand.

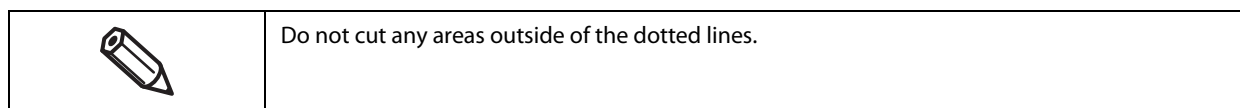

- 7** Pull the nozzle out of the ink cartridge, and clip the tabs to the box.

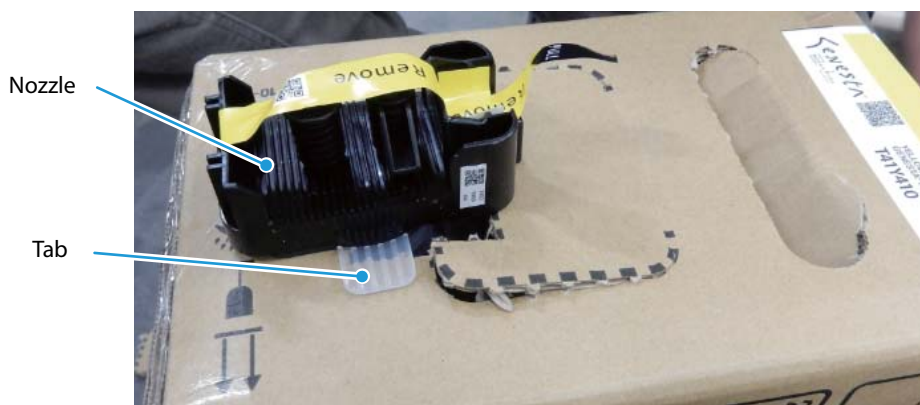

- 8** Remove the sticker from the ink cartridge.



- 9 Pull the ink rack front bar towards you and down.
- 10 Remove the ink cartridge to be replaced from the ink rack. Grab the blue knobs on both sides of the BIB connection unit, and then pull it out toward you.

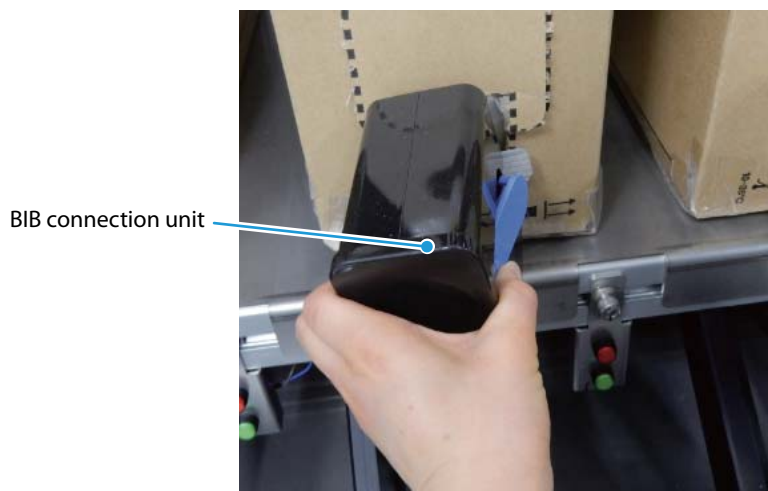

- 11 Lower the ink cartridge to be replaced from the ink rack.
- 12 Set the new ink cartridge in the ink rack.
- 13 Insert the BIB connection unit of the ink rack into the nozzle of the ink cartridge. Push the needle of the BIB connection unit into the nozzle of the ink cartridge. Insert it carefully and securely as shown in the following image.

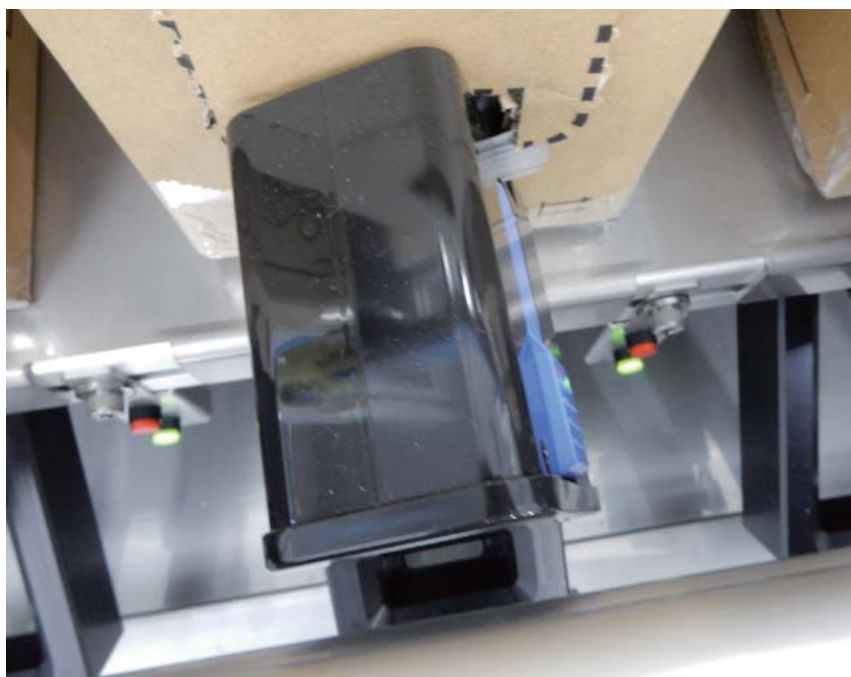

14 Raise the ink rack front bar up.

This completes ink replacement. When the sub-tank is filled with ink, the green LED on the ink rack illuminates.



Changing User Permissions

There are two types of user permissions: "L user permissions" and "H user permissions".

For details on user permissions, refer to ["Symbols in This Manual" on page 8](#).

The procedure for changing permissions is described below.

- 1 Click "Show Hidden Icons" in the Windows taskbar. Click [HookMe].

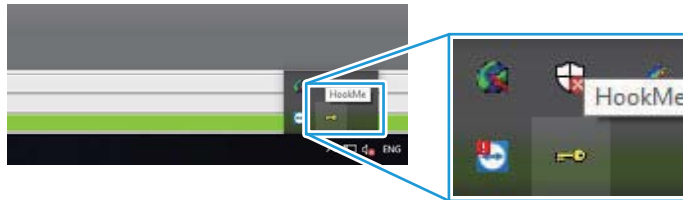

- 2 The [Login] screen is displayed. Enter the user's password, and click [OK].

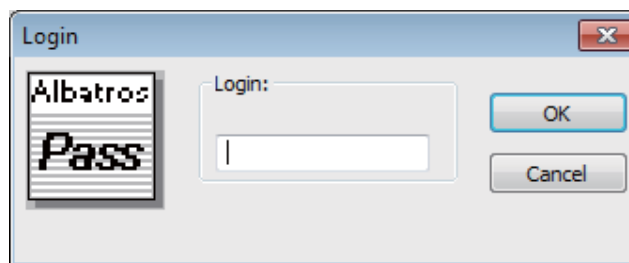

The passwords for the respective user modes are listed below.

L user: L

H user: H

Check the Belt Cleaning Unit Operation

Colour exclusion mode is used for performing printing operations such print head operation and belt feeding without the use of ink.

You can check operation during Colour exclusion mode if you want to check operation of the belt cleaning unit without printing on fabric.



If fabric is already set, belt feeding is performed without printing.

Follow these procedures to use this mode.

- 1 In the [Colours] menu, select [Colour exclusion].

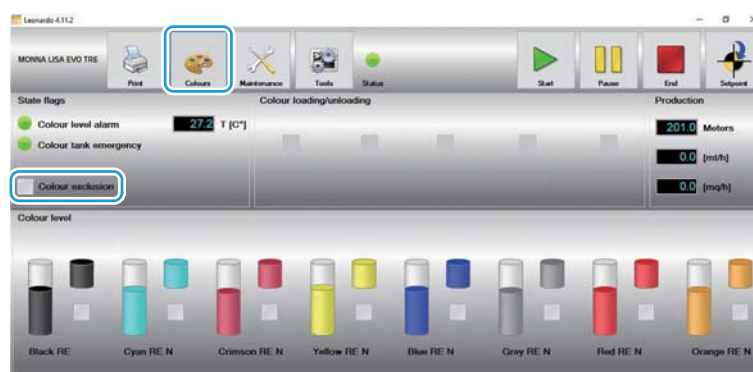

- 2 Click [Start].

Workflow When Turning Off the Power

This section describes the procedure for turning off the power.

1. Inserting the Stopper Pin of the Pressure Roller ([Page 137](#))
2. Lifting Up the Towel Roller ([Page 138](#))
3. Cleaning ([Page 140](#))
4. Exiting Leonardo ([Page 140](#))
5. Turning Off the Control PC ([Page 140](#))
6. Emergency Stop by Use of an Emergency Stop Button ([Page 141](#))
7. Turn off the Main Power ([Page 141](#))
8. Closing the Water Supply Valve on the Belt Cleaning Unit ([Page 142](#))

Inserting the Stopper Pin of the Pressure Roller



CAUTION

Be sure to always insert the pins on the left and right when work is completed. Leaving the hanging low may deform the belt.

- 1 Open the rear protective cover.
- 2 Turn the selection switch (black) to the left and lift up the pressure roller.
- 3 Insert the right-side stopper pin into the pressure roller.



- 4 Insert the left-side pin into the pressure roller.



- 5 Close the rear protective covers.

Lifting Up the Towel Roller

If the towel roller is installed, lift up the towel roller away from the belt.

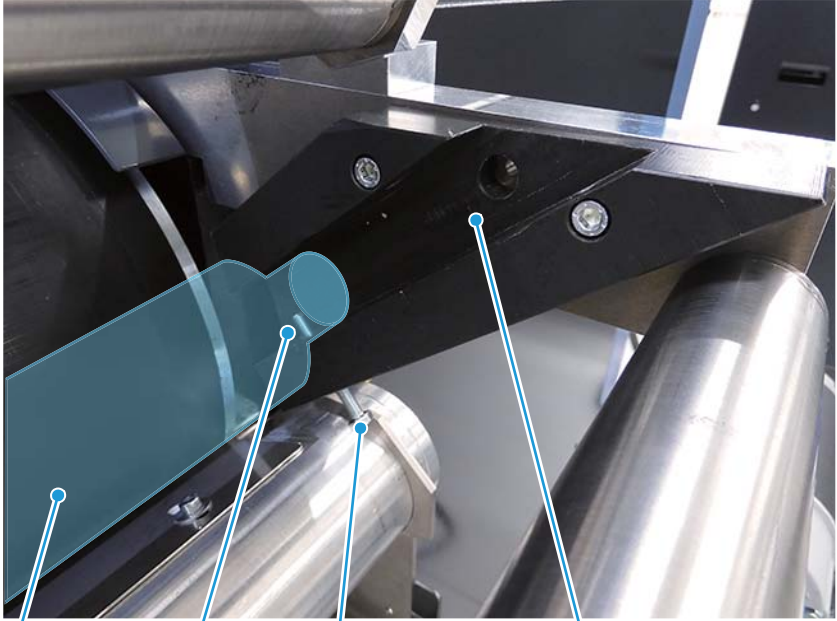
	<p>To lift up the towel roller, lift the towel roller first and tighten the supporting screw with the screw sticking out into the groove. Then, lower the towel roller spindle onto the screw.</p> <p>Towel roller in upper position</p>  <p>Towel roller Supporting screw Towel roller groove</p> <p>Supporting screw sticking out into the groove supports the towel roller spindle</p>
---	--

	<p>If the towel roller is kept in contact with the belt for a long time, glue on the belt may adhere to the towel roller. Keep the towel roller in the lifted position while the machine is not in printing operation.</p>
---	--

- 1 While lifting up the right side of the towel roller toward you, tighten the supporting screw (right) by hand keeping the screw sticking out into the groove.

**CAUTION**

When the screw is loosened, the towel roller automatically lowers under its own weight. Be careful not to get your fingers caught between the towel roller and the belt.

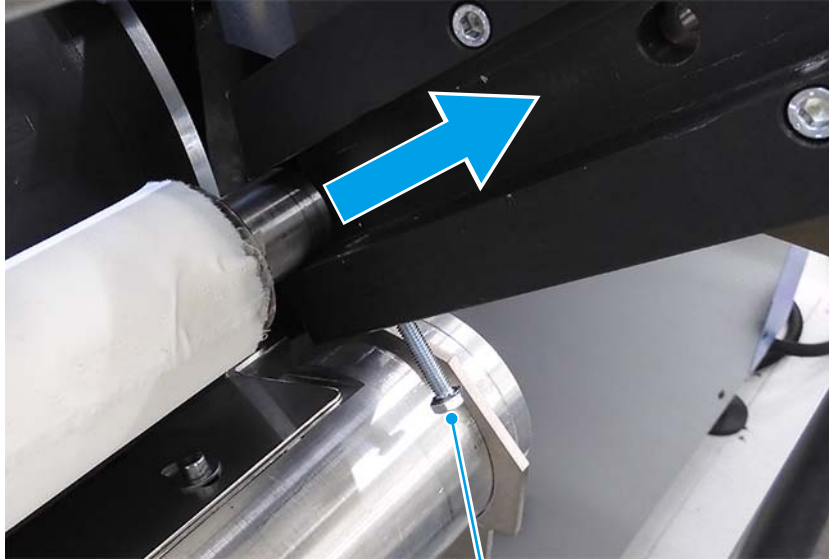

Supporting screw

- 2 Lower the towel roller gradually onto the supporting screw.

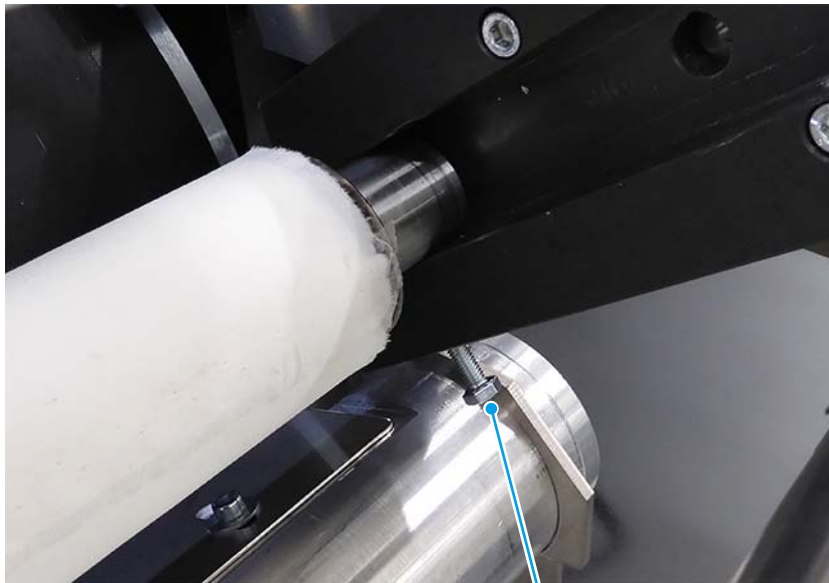

Supporting screw

- 3 Repeat procedures 1 and 2 on the left side of the towel roller.

Cleaning

Wipers and Caps

Refer to the "Maintenance Guide".

Flushing Plate

Refer to the "Maintenance Guide".

Belt (When Using Pigment Ink)

When pigment ink adheres to the belt, an ink film is formed. To prevent ink films, clean the belt referring to the Maintenance Guide.

Exiting Leonardo

Exit Leonardo.

Turning Off the Control PC

Shut down the control PC.

Emergency Stop by Use of an Emergency Stop Button

Push the emergency stop button to put the machine in emergency stop status, so that the print heads and motor do not operate suddenly when the power is turned on.

There are five emergency stop buttons around the machine. Firmly press one of these emergency stop buttons.

Turn off the Main Power

Turn off the power. Turn the Main Power Switch on the Main Electric Box to 0 (OFF).



Closing the Water Supply Valve on the Belt Cleaning Unit

Close the water supply valve at the bottom of the front of the machine.

Open

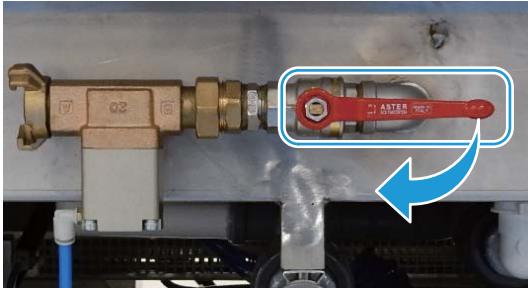

Closed



Troubleshooting

This section describes actions to take when trouble occurs.

Error Messages

This section describes the causes for error messages and the actions that should be taken.

If the trouble is not resolved even after taking these actions, contact the distributor where the machine was purchased for assistance.

Error Messages	Cause	Action
Bag not recognized Do you want to continue?	The ink cartridge is not recognized.	Disconnect the ink cartridge and then connect it again.
Colour doesn't match previous. Do you want to continue?	The color of the ink cartridge has changed.	Check if the ink cartridge is the wrong color.
Bag not inserted	The ink cartridge is not connected correctly.	Check if the BIB connection unit is connected to the nozzle on the ink cartridge correctly. Disconnect the ink cartridge and then connect it again.
Colour tank empty (Audible and light alarm)	Low ink was detected.	Replace the ink cartridge. If the ink cartridge is not replaced, printing will continue until the ink in the reserve tank in the ink system runs out, and then the machine will stop in "Pause" status. After the ink cartridge is replaced, press "Start" to restart printing.
Machine emergency (Light alarm)	An emergency stop button has been pressed. A fault has been detected.	Check the reason why the emergency stop button was pressed. Inspect the machine to see if a fault has occurred. Remove the cause of the fault. Turn off the power to the machine, turn off the system, reset all errors that have occurred, and then restart the system.
Guard emergency	A protective cover is open.	Close the protective cover.
No air	The air pressure is not sufficient. Air is not being supplied.	Check the air pressure. Check the air supply system.
Run machine set-point	Set point has not been executed. Set point has been reset due to a fault.	Execute Set point. If Set point was reset due to a fault, check the cause of the fault and reset it before executing Set point.

Error Messages	Cause	Action
Piece fault.	The fabric to be printed on is not affixed to the belt. There is an abnormality or fault on the surface of the fabric.	Check the fabric, and remove any folds or bulges. Remove the fabric and install it again.
Check piece fault excluded	The foreign material detection sensor is disabled.	Enable the foreign material detection sensor. It is dangerous to print with the foreign material detection sensor disabled. If an abnormality occurs in the fabric, or if the fabric is not affixed to the belt, the print heads could be damaged.
Printing suspended	Printing was paused by request.	Remove the cause for pausing the printer, and then click "Start" to restart printing.
Head height incorrect	The head height is incorrect.	Check the setting value.
Piece too tall	The fabric height is incorrect.	Check the setting value.
Initial design position too small	The print data setting is incorrect.	Increase the value for "Start printing".
Head not in safe position.	The print heads are not in the correct position.	Contact qualified service personnel for assistance.
CARRIAGE. carriage linear motor: Servoerror	The position of the print heads is not recognized due to a mechanical impediment.	Press an "Emergency stop button". Turn off the power to the machine. Remove the cause of the fault. Turn on the power to the machine.
CARRIAGE. carriage linear motor: encoder connection incorrect	The print heads were moved by hand.	
CARRIAGE. carriage linear motor: movement not completed	The print heads cannot move to the specified position due to a mechanical impediment.	
BELT. belt drive motor: Servoerror	The position of the belt is not recognized due to a mechanical impediment.	
BELT. belt drive motor: encoder connection incorrect	The belt was moved by hand.	
BELT. belt drive motor: movement not completed	The belt cannot move to the specified position due to a mechanical impediment.	
"xx-x" albre receiver disconnected	One or more devices have been disconnected from the internal system network.	Press an "Emergency stop button". Turn off the power to the machine. Check the connection of the network cable. Turn on the power to the machine.
"xx" albre receiver disconnected		
"x" albstep receiver disconnected		

Error Messages	Cause	Action
"xx-x" albre receiver: +24cc power supply error	An error has occurred in a +24 V power supply device on the machine.	Press an "Emergency stop button". Turn off the power to the machine. Check the status of the device. Turn on the power to the machine.
"x" albstep receiver: +24cc power supply error		
File opening error	There is an error in the "ROBUST" file in the CAD system.	Delete the file. Create the file again in the CAD system.
File reading error		
Incongruent data in source file		
Quantity of data incorrect in file header		
Too many colour row values specified		
Design file version old		
Design file version not supported		
The height pixels exceed the print capacity		
Height resolution differs from that in the file		
Length resolution differs from that in the file		
Drop type in file incorrect		
Height increments don't match those in the file		
Length increments don't match those in the file		
Out of memory	A problem has occurred in the system memory.	Check if the OS settings on the system PC have been changed. Restart the machine.
There isn't enough memory to run the next band.		
File not found	The file to be printed was not found in the specified directory.	Specify the correct file name and directory.
Dongle error	The system does not recognize the dongle.	Contact qualified service personnel for assistance.
Invalid dongle		
Colours different from those in the machine	The printed color does not match either the file to be printed or the specified color.	If there is no problem with the color to be printed, continue printing. Check the file to be printed.
Colours in design file swapped		

Error Messages	Cause	Action
Print start error	An error or fault has occurred in the control system during system initialization or printing.	Restart the machine.
First pixel error		
Pixel count error		
TIMEMAC error		
REQ error		
Interruption due to TIMEMAC error		
Generic error	An unidentified error has occurred.	Restart the machine.
"Foreign material sensor" detected some foreign materials or a fabric error	The foreign material detection sensor detected foreign material on the belt or wrinkles or folds in the fabric.	Check if there is any foreign material on the belt and if the fabric is wrinkled or folded.
"Head stroke sensor" detected some foreign materials or a fabric error	The head stroke sensor detected foreign material on the belt or wrinkles or folds in the fabric.	Check if there is any foreign material on the belt and if the fabric is wrinkled or folded.
HEAD4 "\$x" DRV "\$x" temperature > "\$x"°	The temperature of the print head drive substrate cannot be lowered.	Clean or replace the cooling fan filters. For more information about cleaning and replacement, refer to the Maintenance Guide.

Print Quality

Condition	Cause	Action
Poor print quality	Faulty discharge of print head	Increase the number of printing passes. (See " Load the Print Data " on page 114) Perform a nozzle check when changing jobs. Check that discharge is normal (normal print quality) before printing.
Mixed ink colors	Ink mixing is occurring in the print head.	Perform manual flushing for the print head. (Refer to " Manual flushing " on page 147)

Manual flushing

Perform manual flushing on the print head to resolve ink color mixing.

1 Click [Maintenance].



2 Click [Manual flushing].



- 3 On the [Color Selection] screen, select the print head for manual flushing. Multiple print heads can be selected.

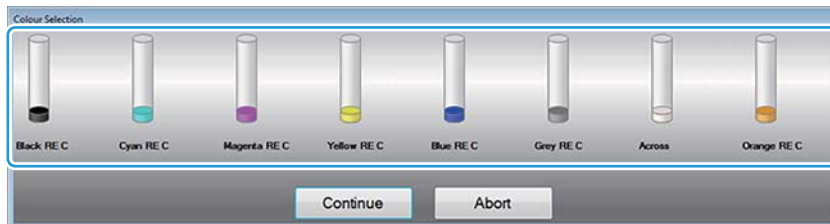

The selected print head changes its display as shown below.

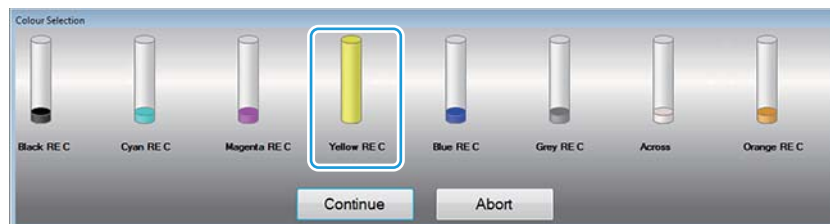

- 4 Click [Continue].
The print head moves over the flushing plate and starts manual flushing. When manual flushing is completed, the print head returns to its original position.
- 5 Perform a nozzle check to see if there is any ink color mixing.
For more information, refer to ["Nozzle Check" on page 84](#).
If the nozzle check pattern has mixed colors, perform manual flushing again.

Print Head Failure

The function described in this section is not installed on EVO TRE 8-180.

If a print head failure occurs, promptly make a request for repairs to be performed.

If a print head failure occurs on this machine, you can configure the settings so that only that specific head column is not printed. The other print heads will cover for the head that does not print. This will cause the print speed to drop, but production can continue until the head is repaired.

	<p>For more information about how to use this function, contact qualified service personnel.</p>
--	--

- 1 Use nozzle check and other functions to identify the print head that has failed.

2 Click "Disable" in Leonardo.



3 Select the check box for the column or row of the print head that has failed, and an "X" will appear at that position.

EVO TRE 16

	<p>We do not recommend unselecting the check boxes for [Group A/Group B] along the bottom of this screen; doing so might adversely affect image quality.</p>
---	--

EVO TRE 32

In this example, head 2L-24 has failed.

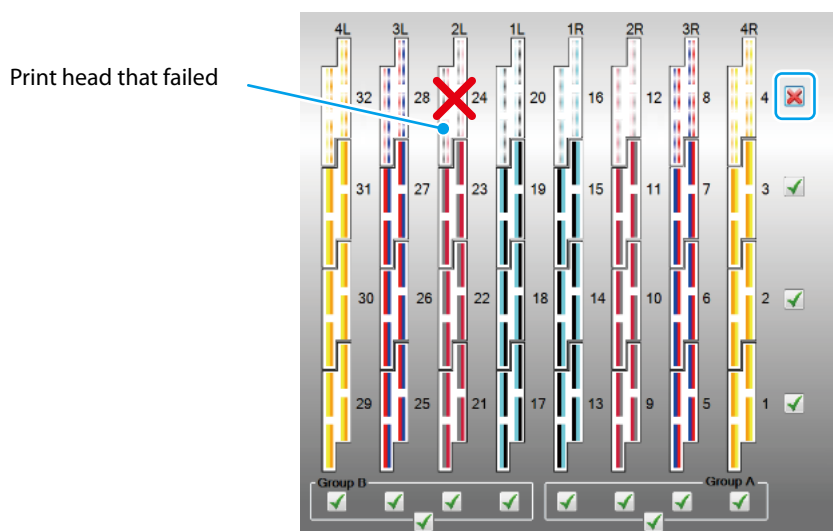

In this case, column 4 will not be used when printing.

	<p>An X cannot be set for only column 2 or only column 3. Use this setting for the columns on the outer edges. We do not recommend unselecting the check boxes for [Group A/Group B] along the bottom of this screen; doing so might adversely affect image quality.</p>
---	---