

EPSON

L4350 Series User's Guide



Printing

Copying

Scanning

Maintaining the Printer

Solving Problems

Contents

Guide to This Manual

Introduction to the Manuals.	6
Important Safety Instructions (paper manual).	6
Start Here (paper manual).	6
User's Guide (digital manual).	6
Information on the Latest Manuals.	6
Searching for Information.	6
Printing Only the Pages You Need.	7
About This Manual.	7
Marks and Symbols.	7
Notes on Screenshots and Illustrations.	8
Operating System References.	8
Trademarks.	9
Copyright.	9

Important Instructions

Safety Instructions.	12
Safety Instructions for Ink.	12
Printer Advisories and Warnings.	13
Advisories and Warnings for Setting Up the Printer.	13
Advisories and Warnings for Using the Printer.	13
Advisories and Warnings for Using the LCD Screen.	14
Advisories and Warnings for Connecting to the Internet.	14
Advisories and Warnings for Using the Printer with a Wireless Connection.	14
Advisories and Warnings for Transporting or Storing the Printer.	14
Notes on the Administrator Password.	14
Protecting Your Personal Information.	16

Part Names and Functions

Front.	18
Inside.	18
Rear.	19

Guide to the Control Panel

Control Panel.	21
Home Screen Configuration.	22
Guide to the Network Icon.	23
Entering Characters.	23

Loading Paper

Paper Handling Precautions.	25
Paper Size and Type Settings.	26
List of Paper Type.	26
Loading Paper.	27
Precautions when Loading Letterhead Paper.	27
Loading Paper in the Rear Paper Feeder.	27
Loading Various Paper.	30
Loading Envelopes in the Rear Paper Feeder.	30
Loading Pre-punched Paper.	32
Loading Long Papers.	32

Placing Originals

Placing Originals on the Scanner Glass.	34
---	----

Printing

Printing Documents.	37
Printing from a Computer.	37
Printing Documents from Mobile Devices.	52
Printing on Envelopes.	54
Printing on Envelopes from a Computer (Windows).	54
Printing on Envelopes from a Computer (Mac OS).	54
Printing Web Pages.	55
Printing Web Pages from a Computer.	55
Printing Web Pages from Mobile Devices.	55
Printing Using a Cloud Service.	56

Copying

Available Copying Methods.	58
Copying Originals.	58
Copying on 2-Sides.	59
Copying by Enlarging or Reducing.	59
Copying Multiple Originals onto One Sheet.	59
Copying ID card.	61
Copying Without Margins.	62
More Menu Options for Copying.	62
The number of copies:.	62
2-Sided:.	62
Print Settings:.	62

Scanning

Basic Information on Scanning.	65
What is a "Scan"?.	65
Scanning Uses.	65
Available Scanning Methods.	65
Recommended File Formats.	66
Recommended Resolutions.	67
Scanning Originals to a Computer.	67
Scanning from the Control Panel.	67
Scanning from a Computer.	69
Scanning Using WSD.	69
Setting Up a WSD Port.	70
Scanning Originals to a Mobile Device.	72
Scanning Using Mopria Scan.	72
Advanced Scanning.	72
Scanning Multiple Photos at the Same Time.	72

Maintaining the Printer

Checking the Ink Level.	75
Reset the Ink Level.	75
Improving Print, Copy, and Scan Quality.	76
Adjusting the Print Quality.	76
Checking and Cleaning the Print Head.	77
Running Power Cleaning.	78
Running Power Ink Flushing.	79
Preventing nozzle clogging.	80
Aligning the Print Head.	81
Cleaning the Paper Path for Ink Smears.	81
Cleaning the Scanner Glass.	81
Cleaning the Translucent Film.	82
Cleaning the Printer.	85
Cleaning Spilled ink.	85

In These Situations

When Replacing a Computer.	87
Saving Power.	87
Disabling your Wi-Fi Connection.	87
Checking the Total Number of Pages Fed Through the Printer.	88
Installing the Applications Separately.	88
Checking if a genuine Epson printer driver is installed - Windows.	89
Checking if a genuine Epson printer driver is installed - Mac OS.	91
Resetting the Network Connection.	91
Adjusting Settings When Connecting to a Computer.	91

Adjusting Settings When Connecting to a Mobile Device.	92
Configuring Wi-Fi Settings from the Control Panel.	93
Checking the Printer's Network Connection Status (Network Connection Report).	96
Messages and Solutions on the Network Connection Report.	97
Connecting a Device and Printer Directly (Wi- Fi Direct).	103
About Wi-Fi Direct.	103
Connecting to Devices using Wi-Fi Direct.	103
Disconnecting Wi-Fi Direct (Simple AP) Connection.	104
Changing the Wi-Fi Direct (Simple AP) Settings Such as the SSID.	105
Adding or Changing the Printer's Connection.	106
To Set Up a Printer on Multiple Computers.	106
Changing the Connection from Wi-Fi to USB.	107
Setting a Static IP Address for the Printer.	108
Transporting and Storing the Printer.	110

Solving Problems

Cannot Print or Scan.	116
Problem Solving.	116
The Application or Printer Driver do not Work Properly.	117
The Printer Cannot Connect to the Network.	121
Paper Does Not Feed Properly.	124
Printing, Copying, and Scanning Quality is Poor.	127
Print Quality is Poor.	127
Copy Quality is Poor.	136
Scanned Image Problems.	142
Cannot Select Paper Type or Paper Source in Printer Driver.	145
A genuine Epson printer driver has not been installed.	145
An Error Code is Displayed on the LCD Screen.	145
Paper Gets Jammed.	146
Removing Jammed Paper.	146
Preventing Paper Jams.	149
It is Time to Refill the Ink.	150
Ink Bottle Handling Precautions.	150
Refilling the Ink Tank.	151
It is Time to Replace the Maintenance Box.	156
Maintenance Box Handling Precautions.	156
Replacing a Maintenance Box.	157
Cannot Operate the Printer as Expected.	160
The Printer Does Not Turn On or Off.	160

Operations are Slow.	162
LCD Screen Gets Dark.	163
The Printer Is Loud.	163
The Root Certificate Needs to be Updated.	164
Cannot Perform Manual 2-sided Printing (Windows).	164
The Print Settings Menu is Not Displayed (Mac OS).	164
A Message Prompting You to Reset the Ink Level is Displayed Even After Refilling the Ink.	165
The Ink Level Display does not Change Even After Refilling the Ink.	165
Cannot Solve Problem.	165
Cannot Solve Printing or Copying Problems.	165

Product Information

Paper Information.	168
Available Paper and Capacities.	168
Unavailable Paper Types.	171
Consumable Products Information.	171
Ink Bottle Codes.	171
Maintenance Box Code.	172
Software Information.	172
Application for Printing from a Computer (Windows Printer Driver).	172
Application for Printing from a Computer (Mac OS Printer Driver).	173
Application for Controlling the Scanner (Epson Scan 2).	174
Application for Configuring Printer Operations (Web Config).	174
Application for Updating Software and Firmware (Epson Software Updater).	175
Settings Menu List.	176
Printer Setup.	176
Network Settings.	178
Epson Connect Services.	180
Print Status Sheet.	180
Print Counter.	180
Customer Research.	181
Restore Default Settings.	181
Firmware Update.	181
Product Specifications.	182
Printer Specifications.	182
Scanner Specifications.	183
Interface Specifications.	183
Network Specifications.	184
Supported Third Party Services.	185
Dimensions.	186
Electrical Specifications.	186

Environmental Specifications.	187
System Requirements.	187
Regulatory Information.	188
Standards and Approvals for Mongolian Model.	188
Restrictions on Copying.	188
Nameplate.	188

Where to Get Help

Technical Support Web Site.	190
Contacting Epson Support.	190
Before Contacting Epson.	190
Help for Users in the U.S. and Canada.	190
Help for Users in Latin America.	191
Help for Users in Europe.	192
Help For Users in Middle East, Turkey, Africa, Central and West Asia.	192
Help for Users in Taiwan.	193
Help for Users in Australia.	193
Help for Users in New Zealand.	194
Help for Users in Singapore.	194
Help for Users in Thailand.	194
Help for Users in Vietnam.	195
Help for Users in Indonesia.	195
Help for Users in Hong Kong.	196
Help for Users in Malaysia.	196
Help for Users in India.	196
Help for Users in the Philippines.	197
Help for Users in South Korea.	198

Guide to This Manual

Introduction to the Manuals.	6
Searching for Information.	6
Printing Only the Pages You Need.	7
About This Manual.	7
Trademarks.	9
Copyright.	9

Introduction to the Manuals

The following manuals are supplied with your Epson printer. As well as the manuals, check the various types of help information available from the printer itself or from the Epson software applications.

Important Safety Instructions (paper manual)

Provides you with instructions to ensure the safe use of this printer.

Start Here (paper manual)

Provides you with information on setting up the printer and installing the software.

User's Guide (digital manual)

This manual. Available as a PDF and Web manual. Provides detailed information and instructions on using the printer and solving problems.

Information on the Latest Manuals

Paper manual

Visit the Epson Europe support website at <https://www.epson.eu/support>, or the Epson worldwide support website at <https://support.epson.net/>.

Digital manual

Visit the following website, enter the product name, and then go to **Support**.

<https://epson.sn>

Searching for Information

The PDF manual allows you to search for information you are looking for by keyword, or jump directly to specific sections using the bookmarks. This section explains how to use a PDF manual that has been opened in Adobe Acrobat Reader on your computer.

Searching by keyword

Click **Menu** > **Search** > **Advanced Search**. Enter the keyword (text) for information you want to find in the search window, and then click **Search**. Hits are displayed as a list. Click one of the displayed hits to jump to that page.

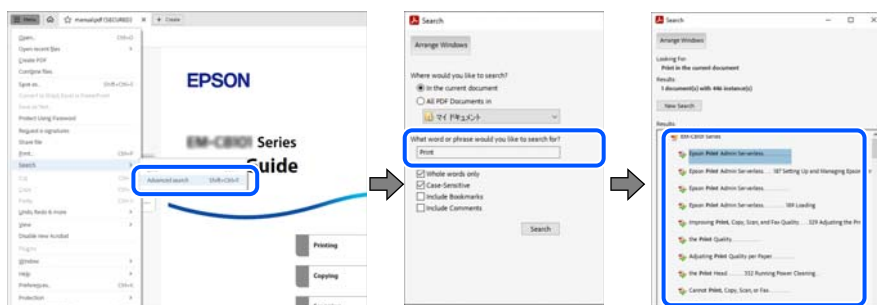

Jumping directly from bookmarks

Click a title to jump to that page. Click + or > to view the lower level titles in that section. To return to the previous page, perform the following operation on your keyboard.

- Windows: Hold down **Alt**, and then press ←.
- Mac OS: Hold down the command key, and then press ←.

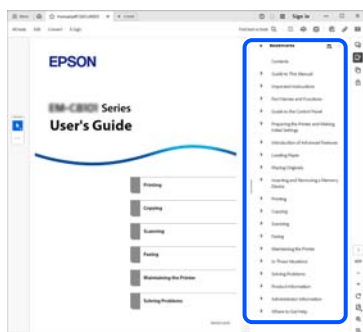

Printing Only the Pages You Need

You can extract and print only the pages you need. Click **Print** in the **File** menu, and then specify the pages you want to print in **Pages in Pages to Print**.

- To specify a series of pages, enter a hyphen between the start page and the end page.
Example: 20-25
- To specify pages that are not in series, divide the pages with commas.
Example: 5, 10, 15

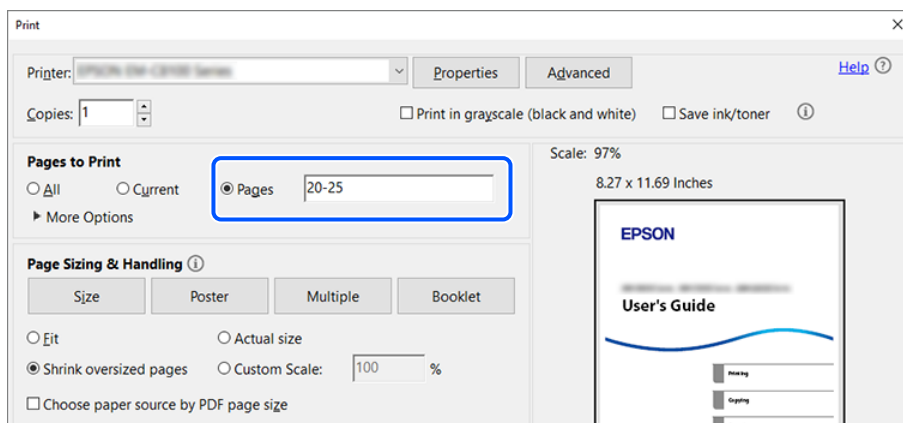

About This Manual

This section explains the meaning of marks and symbols, notes on descriptions, and operating system reference information used in this manual.

Marks and Symbols



Caution:

Instructions that must be followed carefully to avoid bodily injury.



Important:

Instructions that must be observed to avoid damage to your equipment.

Note:

Provides complementary and reference information.

Related Information

➔ A link to a related section



Provides Web Video Manuals of the operating instructions. See the related information link.

Notes on Screenshots and Illustrations

- Screenshots of the printer driver are from Windows 11 or macOS High Sierra (10.13). The content displayed on the screens varies depending on the model and situation.
- Illustrations used in this manual are examples only. Although there may be slight differences depending on the model, the method of operation is the same.
- Some of the menu items on the LCD screen vary depending on the model and settings.
- You can read the QR code using a dedicated app.

Operating System References

Windows

In this manual, terms such as "Windows 11", "Windows 10", "Windows 8.1", "Windows 8", "Windows 7", "Windows Server 2022", "Windows Server 2019", "Windows Server 2016", "Windows Server 2012 R2", "Windows Server 2012", "Windows Server 2008 R2", and "Windows Server 2008" refer to the following operating systems. Additionally, "Windows" is used to refer to all versions.

- Microsoft® Windows® 11 operating system
- Microsoft® Windows® 10 operating system
- Microsoft® Windows® 8.1 operating system
- Microsoft® Windows® 8 operating system
- Microsoft® Windows® 7 operating system
- Microsoft® Windows Server® 2022 operating system
- Microsoft® Windows Server® 2019 operating system
- Microsoft® Windows Server® 2016 operating system
- Microsoft® Windows Server® 2012 R2 operating system
- Microsoft® Windows Server® 2012 operating system
- Microsoft® Windows Server® 2008 R2 operating system
- Microsoft® Windows Server® 2008 operating system

Mac OS

In this manual, "Mac OS" is used to refer to Mac OS X 10.9.5 or later as well as macOS 11 or later.

Trademarks

- ❑ Microsoft, Microsoft Edge, Windows and Windows Server are trademarks of the Microsoft group of companies.
- ❑ Apple, Mac, macOS, OS X, Bonjour, Safari, AirPrint, iPad, iPhone, iPod touch, and App Store are trademarks of Apple Inc., registered in the U.S. and other countries.
- ❑ Use of the Works with Apple badge means that an accessory has been designed to work specifically with the technology identified in the badge and has been certified by the developer to meet Apple performance standards.
- ❑ IOS is a trademark or registered trademark of Cisco in the U.S. and other countries and is used under license.
- ❑ Android, Chrome, ChromeOS, Chromebook, and Google Play are trademarks of Google LLC.
- ❑ Adobe, Acrobat, and Reader are either registered trademarks or trademarks of Adobe in the United States and/or other countries.
- ❑ QR Code is a registered trademark of DENSO WAVE INCORPORATED in Japan and other countries.
- ❑ Firefox is a trademark of the Mozilla Foundation in the U.S. and other countries.
- ❑ The Mopria™ word mark and the Mopria™ Logo are registered and/or unregistered trademarks of Mopria Alliance, Inc. in the United States and other countries. Unauthorized use is strictly prohibited.
- ❑ Wi-Fi® and Wi-Fi Direct® are registered trademarks of Wi-Fi Alliance®. Wi-Fi Protected Setup™, WPA™, WPA2™, WPA3™ are trademarks of Wi-Fi Alliance®.
- ❑ The Bluetooth® word mark and logos are registered trademarks owned by Bluetooth SIG, Inc. and any use of such marks by Seiko Epson Corporation is under license.
- ❑ General Notice: All other trademarks are the property of their respective owners and used for identification purposes only.

Copyright

No part of this publication may be reproduced, stored in a retrieval system, or transmitted in any form or by any means, electronic, mechanical, photocopying, recording, or otherwise, without the prior written permission of Seiko Epson Corporation. No patent liability is assumed with respect to the use of the information contained herein. Neither is any liability assumed for damages resulting from the use of the information herein. The information contained herein is designed only for use with this Epson product. Epson is not responsible for any use of this information as applied to other products.

Neither Seiko Epson Corporation nor its affiliates shall be liable to the purchaser of this product or third parties for damages, losses, costs, or expenses incurred by the purchaser or third parties as a result of accident, misuse, or abuse of this product or unauthorized modifications, repairs, or alterations to this product, or (excluding the U.S.) failure to strictly comply with Seiko Epson Corporation's operating and maintenance instructions.

Seiko Epson Corporation and its affiliates shall not be liable for any damages or problems arising from the use of any options or any consumable products other than those designated as Original Epson Products or Epson Approved Products by Seiko Epson Corporation.

Seiko Epson Corporation shall not be held liable for any damage resulting from electromagnetic interference that occurs from the use of any interface cables other than those designated as Epson Approved Products by Seiko Epson Corporation.

© 2025 Seiko Epson Corporation

The contents of this manual and the specifications of this product are subject to change without notice.

Important Instructions

Safety Instructions.	12
Printer Advisories and Warnings.	13
Protecting Your Personal Information.	16

Safety Instructions

Read and follow these instructions to ensure safe use of this printer. Make sure you keep this manual for future reference. Also, be sure to follow all warnings and instructions marked on the printer.

- Use only the power cord supplied with the printer and do not use the cord with any other equipment. Use of other cords with this printer or the use of the supplied power cord with other equipment may result in fire or electric shock.
- If the power cord that comes with your printer has a grounding pin, connect the printer to a grounded outlet. Failure to follow this instruction may result in fire or electric shock.
- Be sure your power cord meets the relevant local safety standard.
- Never disassemble, modify, or attempt to repair the power cord, plug, printer unit, scanner unit, or options by yourself, except as specifically explained in the printer's manuals.
- Unplug the printer and refer servicing to qualified service personnel under the following conditions:
The power cord or plug is damaged; liquid has entered the printer; the printer has been dropped or the casing damaged; the printer does not operate normally or exhibits a distinct change in performance. Do not adjust controls that are not covered by the operating instructions.
- Place the printer near a wall outlet where the plug can be easily unplugged.
- Do not place or store the printer outdoors, near excessive dirt or dust, water, heat sources, or in locations subject to shocks, vibrations, high temperature or humidity.
- Take care not to spill liquid on the printer and not to handle the printer with wet hands.
- Keep the printer at least 22 cm (8.7 in.) away from cardiac pacemakers. Radio waves from this printer may adversely affect the operation of cardiac pacemakers.
- If the LCD screen is damaged, contact Epson support (U.S. and Canada) or your dealer (other regions). If the liquid crystal solution gets on your hands, wash them thoroughly with soap and water. If the liquid crystal solution gets into your eyes, flush them immediately with water. If discomfort or vision problems remain after a thorough flushing, see a doctor immediately.

Safety Instructions for Ink

- Be careful not to touch any ink when you handle the ink tanks, ink tank caps, and opened ink bottles or ink bottle caps.
 - If ink gets on your skin, wash the area thoroughly with soap and water.
 - If ink gets into your eyes, flush them immediately with water. If discomfort or vision problems continue after a thorough flushing, see a doctor immediately.
 - If ink gets into your mouth, see a doctor right away.
- Do not disassemble the maintenance box; otherwise ink may get into your eyes or on your skin.
- Do not shake an ink bottle too vigorously or subject it to strong impacts as this can cause ink to leak.
- Keep ink bottles and maintenance box out of the reach of children. Do not drink the ink.

Printer Advisories and Warnings



Read and follow these instructions to avoid damaging the printer or your property. Make sure you keep this manual for future reference.

Advisories and Warnings for Setting Up the Printer

- Do not block or cover the vents and openings in the printer.
- Use only the type of power source indicated on the printer's label.
- Avoid using outlets on the same circuit as photocopiers or air control systems that regularly switch on and off.
- Avoid electrical outlets controlled by wall switches or automatic timers.
- Keep the entire computer system away from potential sources of electromagnetic interference, such as loudspeakers or the base units of cordless telephones.
- The power-supply cords should be placed to avoid abrasions, cuts, fraying, crimping, and kinking. Do not place objects on top of the power-supply cords and do not allow the power-supply cords to be stepped on or run over. Be particularly careful to keep all the power-supply cords straight at the ends.
- If you use an extension cord with the printer, make sure that the total ampere rating of the devices plugged into the extension cord does not exceed the cord's ampere rating. Also, make sure that the total ampere rating of all devices plugged into the wall outlet does not exceed the wall outlet's ampere rating.
- If you plan to use the printer in Germany, the building installation must be protected by a 10 or 16 amp circuit breaker to provide adequate short-circuit protection and over-current protection for the printer.
- When connecting the printer to a computer or other device with a cable, ensure the correct orientation of the connectors. Each connector has only one correct orientation. Inserting a connector in the wrong orientation may damage both devices connected by the cable.
- Place the printer on a flat, stable surface that extends beyond the base of the printer in all directions. The printer will not operate properly if it is tilted at an angle.
- Allow space above the printer so that you can fully raise the document cover.
- Leave enough space in front of the printer for the paper to be fully ejected.
- Avoid places subject to rapid changes in temperature and humidity. Also, keep the printer away from direct sunlight, strong light, or heat sources.

Advisories and Warnings for Using the Printer

- Do not insert objects through the slots in the printer.
- Do not put your hand inside the printer during printing.
- Do not touch the white flat cable and ink tubes inside the printer.
- Do not use aerosol products that contain flammable gases inside or around the printer. Doing so may cause fire.
- Do not move the print head by hand; otherwise, you may damage the printer.
- Be careful not to trap your fingers when closing the scanner unit.
- Do not press too hard on the scanner glass when placing originals.

- Prolonged use of the printer when the ink level is below the lower line could damage the printer. Fill the ink tank to the upper line while the printer is not operating. To display the correct ink level estimate, reset the ink level after filling the tank.
- Always turn the printer off using the  button. Do not unplug the printer or turn off the power at the outlet until the  light stops flashing.
- If you are not going to use the printer for a long period, be sure to unplug the power cord from the electrical outlet.

Advisories and Warnings for Using the LCD Screen

- The LCD screen may contain a few small bright or dark spots, and because of its features it may have an uneven brightness. These are normal and do not indicate that it is damaged in any way.
- Only use a dry, soft cloth for cleaning. Do not use liquid or chemical cleaners.
- The exterior cover of the LCD screen could break if it receives a heavy impact. Contact your dealer if the screen's surface chips or cracks, and do not touch or attempt to remove the broken pieces.

Advisories and Warnings for Connecting to the Internet

Do not connect this product to the Internet directly. Connect it to a network protected by a router or firewall.

Advisories and Warnings for Using the Printer with a Wireless Connection

- Radio waves from this printer may negatively affect the operation of medical electronic equipment, causing it to malfunction. When using this printer inside medical facilities or near medical equipment, follow directions from the authorized personnel representing the medical facilities, and follow all posted warnings and directions on the medical equipment.
- Radio waves from this printer may negatively affect the operation of automatically controlled devices such as automatic doors or fire alarms, and could lead to accidents due to malfunction. When using this printer near automatically controlled devices, follow all posted warnings and directions on these devices.

Advisories and Warnings for Transporting or Storing the Printer

- When storing or transporting the printer, avoid tilting it, placing it vertically, or turning it upside down; otherwise ink may leak.
- Before transporting the printer, make sure that the print head is in the home (far right) position.

Notes on the Administrator Password

This printer allows you to set an administrator password to prevent unauthorized access or changes to the device settings and network settings stored in the product when connecting to a network.

Default Value of the Administrator Password

The default value of the administrator password is printed on a label on the product, such as one of the labels shown below.

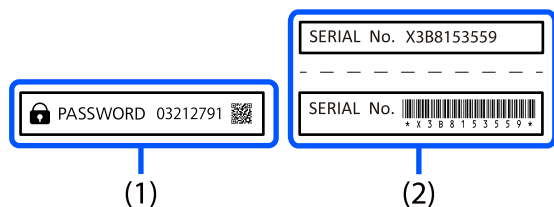

If both labels (1) and (2) are attached, the value next to PASSWORD written on the label in (1) is the default value. In this example, the default value is 03212791.

Note:

As the label (1) may be attached in a location that is difficult to see, check the information in the link to confirm the location.

<https://support.epson.net/manu/adminpw/index.html>

If you cannot find the label (1), the serial number printed on the label in (2) is the default value. In this example, the default value is X3B8153559.

Changing the Administrator Password

For security reasons, we recommend changing the initial password.

It can be changed from Web Config and Epson Device Admin. When changing the password, set it with at least 8 single-byte alphanumeric characters and symbols.

Related Information

➔ [“Running Web Config on a Web Browser” on page 175](#)

Operations that Require You to Enter the Administrator Password

If you are prompted to enter the administrator password when performing the following operations, enter the administrator password set on the printer.

- When updating the firmware of the printer from a computer or mobile device
- When logging on to the advanced settings of Web Config
- When setting using an application that can change the printer's settings

Initializing the Administrator Password

You can return the administrator password to its default setting by initializing the network settings.

Related Information

➔ [“Restore Default Settings” on page 181](#)

Protecting Your Personal Information

When you give the printer to someone else or dispose of it, erase all the personal information stored in the printer's memory by selecting **More > Settings > Restore Default Settings > Clear All Data and Settings** on the control panel.

Part Names and Functions

Front.	18
Inside.	18
Rear.	19

Front

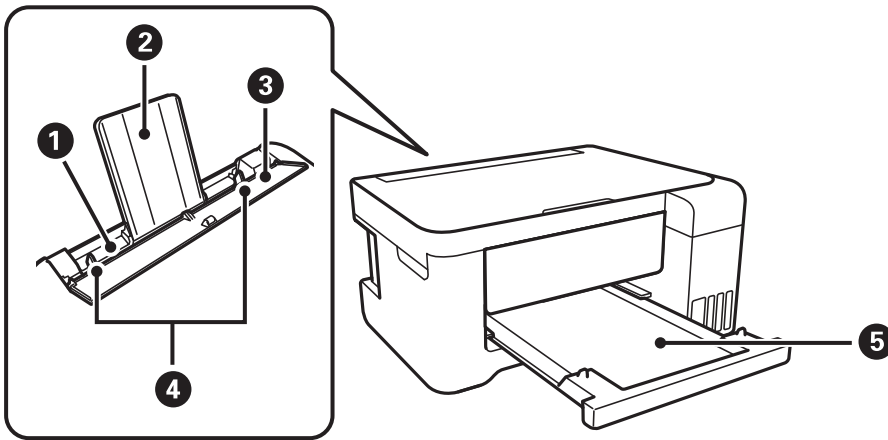

①	Rear paper feeder	Loads paper.
②	Paper support	Supports loaded paper.
③	Feeder guard	Prevents foreign substance from entering the printer. Usually keep this guard closed.
④	Edge guide	Feeds the paper straight into the printer. Slide to the edges of the paper.
⑤	Output tray (G)	Holds the ejected paper.

Inside

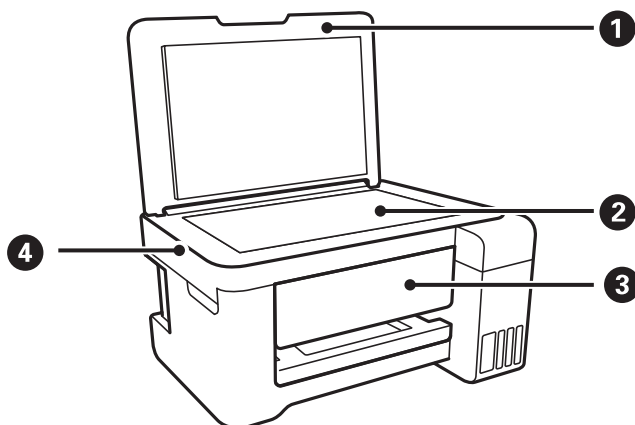

①	Document cover	Blocks external light while scanning.
②	Scanner glass	Place the originals.
③	Control panel	Allows you to make settings and perform operations on the printer.
④	Scanner unit	Scans placed originals.

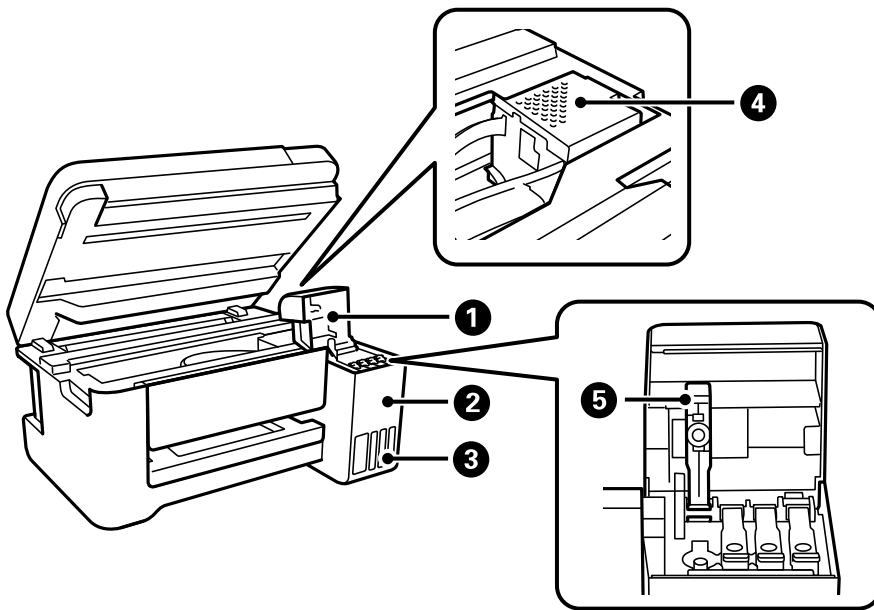

1	Ink tank cover	Open to refill the ink tank.
2	Ink tank unit	Contains the ink tanks.
3	Ink reservoir tank (Ink tank)	Supplies ink to the print head.
4	Print head	Ink is ejected from the print head nozzles underneath.
5	Ink tank cap	Open to refill the ink tank.

Rear

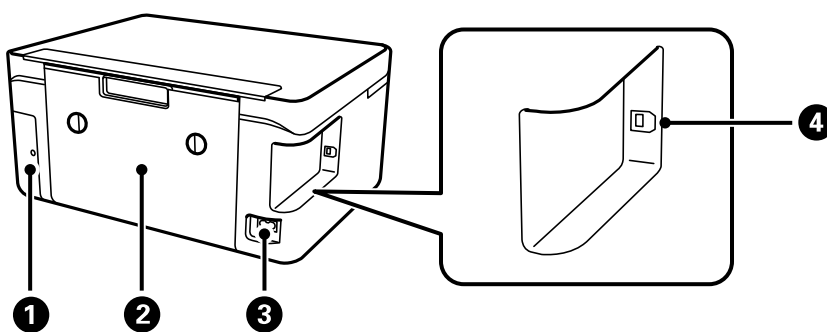

1	Maintenance box cover (L)	Remove when replacing the maintenance box. The maintenance box is a container that collects a very small amount of surplus ink during cleaning or printing.
2	Rear cover (D)	Remove when removing jammed paper.
3	AC inlet	Connects the power cord.
4	USB port	Connects a USB cable to connect with a computer.

Guide to the Control Panel

Control Panel.	21
Home Screen Configuration.	22
Entering Characters.	23

Control Panel

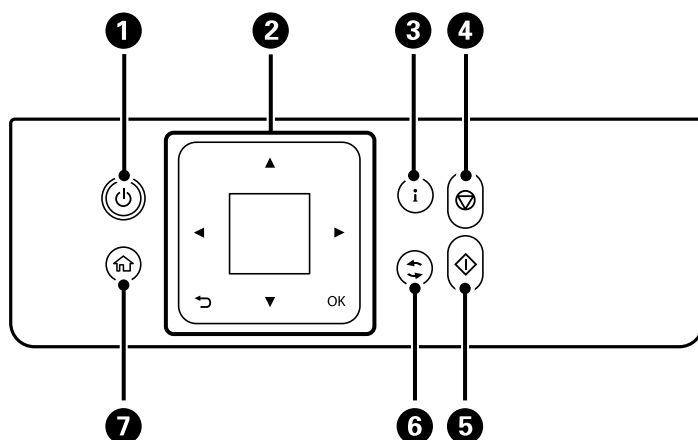







<p>❶</p>	<p>Turns the printer on or off. Make sure the power light is off before you unplug the power cord.</p>
<p>❷</p>	<p>Screen Displays menus and messages. Use buttons on the control panel to select menus or settings.</p> <p>▲ ▼ ◀ ▶ buttons and OK button Use the ▲ ▼ ◀ ▶ buttons to highlight a menu or setting, and then press the OK button to select it.</p> <p>↶ button Press this button to return to the previous screen.</p>
<p>❸</p>	<p>Press this button to display the printer's status or solutions when an issue occurs. You can also check the network connection status. "Guide to the Network Icon" on page 23</p>
<p>❹</p>	<p>Press this button to stop the current operation.</p>
<p>❺</p>	<p>Press this button to start an operation such as printing or copying.</p>
<p>❻</p>	<p>Applies to a variety of functions depending on the situation.</p>
<p>❼</p>	<p>Press this button to display the home screen.</p>

Home Screen Configuration





The following home screen is displayed when you turn on the printer or press the  button on the control panel. You can easily copy and print by switching the menu and selecting the option you need.



	<p>Allows you to copy documents.</p>
	<p>Allows you to scan documents and save them to a computer.</p>
	<p>Allows you to scan documents and save them to a computer using the WSD feature.</p>
	<p>Allows you to select the paper size and paper type you loaded in the paper source.</p>
	<p>Displays menus that allow you to set up the printer for use on a wireless network.</p>
	<p>Allows you to access the following menus:</p> <ul style="list-style-type: none"> <input type="checkbox"/> Maintenance Displays the menus that allow you to improve the quality of your printouts, such as by unclogging nozzles or aligning the print head. <input type="checkbox"/> Settings Allows you to select settings related to maintenance, printer functions, and operations. <input type="checkbox"/> Print failure Provides solutions when you cannot print as expected. <input type="checkbox"/> Quiet Mode Displays Quiet Mode setting. When this feature is enabled, the noise made by printer may be reduced depending on the selected paper type and print quality, but print speed may decrease.

Guide to the Network Icon





You can check the network connection status by pressing the **i** button and selecting **Printer Status > Network Status**.

	The printer is not connected to a wireless (Wi-Fi) network.
	The printer is searching for an SSID or unset IP address, or having a problem with a wireless (Wi-Fi) network.
	The printer is connected to a wireless (Wi-Fi) network. The number of bars indicates the signal strength of the connection. The more bars there are, the stronger the connection.
	The printer is not connected to a wireless (Wi-Fi) network in Wi-Fi Direct (Simple AP) mode.
	The printer is connected to a wireless (Wi-Fi) network in Wi-Fi Direct (Simple AP) mode.

Entering Characters

To enter characters and symbols for network settings from the control panel, use the ▲, ▼, ◀, and ▶ buttons and the software keyboard on the LCD screen. Press the ▲, ▼, ◀, or ▶ button to select a character or function button on the keyboard, and then press the OK button. When you have finished entering characters, select **OK** on the LCD screen, and then press the OK button on the printer.



Function button	Descriptions
	Moves the cursor to the left or right.
A 1 #	Switches the character type. You can enter letters, numbers, or symbols. You can also switch the character type by using the  button on the printer.
	Enters a space.
	Deletes the character to the left (backspace).
OK	Enters the selected characters.

Loading Paper

Paper Handling Precautions.	25
Paper Size and Type Settings.	26
Loading Paper.	27
Loading Various Paper.	30

Paper Handling Precautions

- ❑ Read the instruction sheets supplied with the paper.
- ❑ To achieve high-quality printouts with genuine Epson paper, use the paper in the environment stated on the instruction sheets supplied with the paper.
- ❑ Fan and align the edges of the paper before loading. Do not fan or curl photo paper. Doing so may damage the printable side.

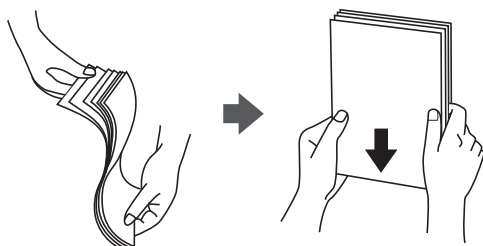

- ❑ If the paper is curled or folded, flatten it or curl it slightly in the opposite direction before loading. Printing on curled or folded paper may cause paper feeding problems and smears on the printouts.



- ❑ Paper feed problems may occur for manual 2-sided printing when printing on one side of pre-printed paper. Reduce the number of sheets to half or less, or load one sheet of paper at a time if paper jams continue.
- ❑ Make sure you are using long-grain paper. If you are not sure what type of paper you are using, check the paper packaging or contact the manufacturer to confirm the paper specifications.
- ❑ Fan and align the edges of envelopes before loading. When stacked envelopes are puffed up with air, press them down to flatten them before loading.



Related Information

- ➔ [“Available Paper and Capacities” on page 168](#)
- ➔ [“Unavailable Paper Types” on page 171](#)

Paper Size and Type Settings

If you register the paper size and type on the screen displayed when you load paper, the printer informs you when the registered information and print settings differ. This prevents you from wasting paper and ink by making sure you are not printing on the wrong paper size or printing in the wrong color due to using settings that do not match the paper type.

This screen is not displayed if you have disabled **Paper Setup Auto Display**. If you disable this feature, you cannot print from an iPhone, iPad, or iPod touch using AirPrint.

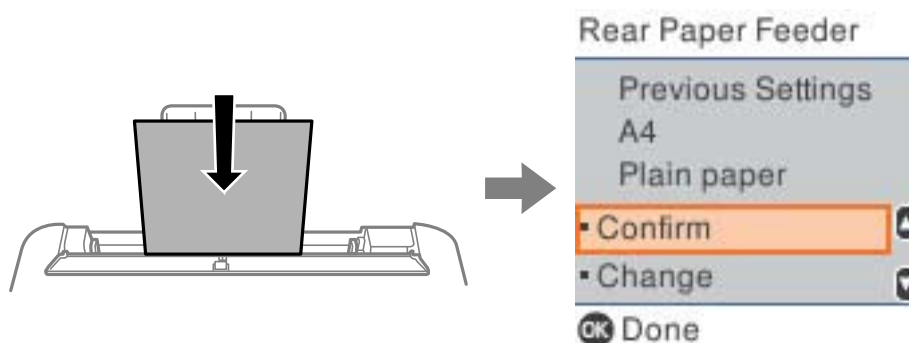

If displayed paper size and type differ from the loaded paper, change the settings for the paper size and paper type, and then confirm them.

Note:

You can also display the paper size and paper type settings screen by selecting **Settings > Printer Setup > Paper Source Settings > Paper Setting**.

Related Information

➔ [“Paper Setup Auto Display:” on page 176](#)

List of Paper Type

To obtain optimum printing results, select the paper type that suits the paper.

Media Name	Media Type	
	Control Panel	Printer Driver, Mobile Device
Epson Bright White Paper	Plain paper	Plain paper
Epson Ultra Premium Photo Paper Glossy	Ultra Glossy	Epson Ultra Glossy
Epson Premium Photo Paper Glossy	Prem. Glossy	Epson Premium Glossy
Epson Premium Photo Paper Semi-gloss	Prem. Semigloss	Epson Premium Semigloss
Epson Photo Paper Glossy	Glossy	Photo Paper Glossy

Media Name	Media Type	
	Control Panel	Printer Driver, Mobile Device
Epson Premium Presentation Paper Matte Epson Premium Presentation Paper Matte Double-sided	Matte	Epson Matte
Epson Presentation Paper Matte Epson Photo Quality Self Adhesive Sheets	Photo Quality Ink Jet	Epson Photo Quality Ink Jet

Loading Paper

Precautions when Loading Letterhead Paper

- For letterhead paper, select **Letterhead** as the paper type.
- For letterhead paper, if you print on paper that is smaller than the setting in the printer driver, the printer may print beyond the edges of the paper which can lead to ink smears on your printouts and excess ink building up inside the printer. Make sure you select the correct paper size setting.
- 2-sided printing and borderless printing are not available for letterhead paper. Also, the print speed may be slower.

Loading Paper in the Rear Paper Feeder

1. Open the feeder guard and pull out the paper support.

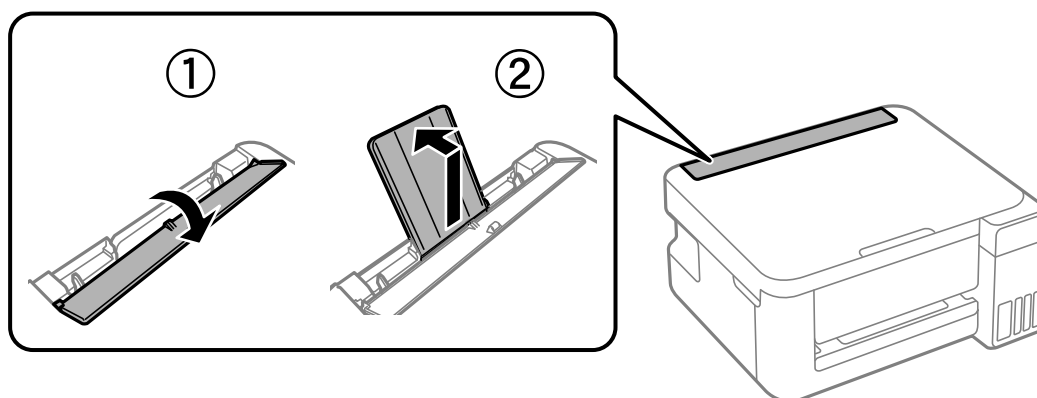

2. Slide the edge guides.

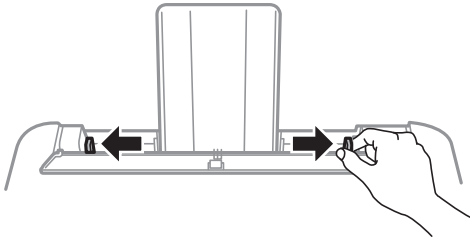

3. Load paper at the center of the paper support with the printable side facing up.

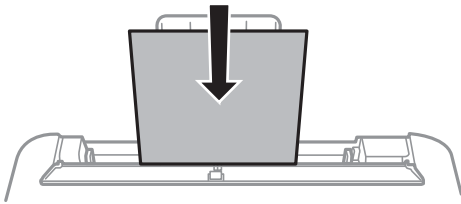

! *Important:*

- Do not load more than the maximum number of sheets specified for the paper. For plain paper, do not load above the line just under the ▼ symbol inside the edge guide.*
- Load paper short edge first. However, when you have set the long edge as the width of the user defined size, load paper long edge first.*

4. Slide the edge guides to the edges of the paper.

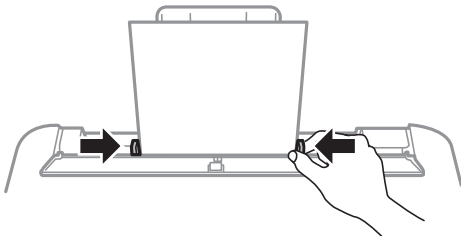

5. Tilt the feeder guard until part (A) is not touching the paper.

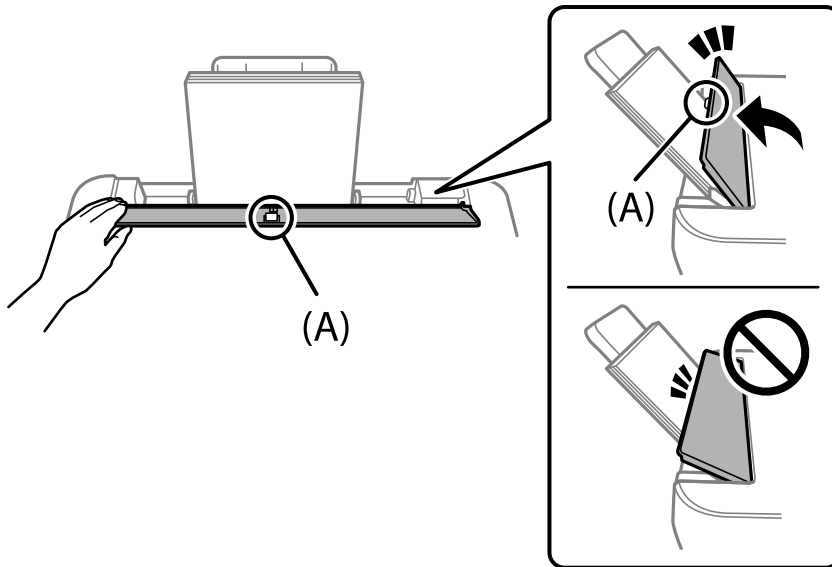

! Important:

- Do not place objects on the feeder guard. Doing so may prevent paper from feeding.
- The feeder guard is designed to stop halfway to prevent paper feed problems. Tilt it until it stops.

6. Select the paper size and paper type.

Note:

- For letterhead paper, select **Letterhead** as the paper type.
- For letterhead paper, if you print on paper that is smaller than the setting in the printer driver, the printer may print beyond the edges of the paper which can lead to ink smears on your printouts and excess ink building up inside the printer. Make sure you select the correct paper size setting.
- 2-sided printing and borderless printing are not available for letterhead paper. Also, the print speed may be slower.

7. Slide out the output tray.

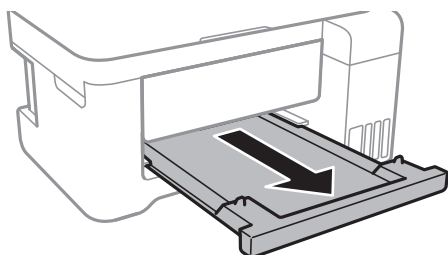

Note:

Return the remaining paper to its package. If you leave it in the printer, the paper may curl or the print quality may decline.

Related Information

- ➔ [“Paper Size and Type Settings” on page 26](#)
- ➔ [“Available Paper and Capacities” on page 168](#)

➔ “Unavailable Paper Types” on page 171

Loading Various Paper

Loading Envelopes in the Rear Paper Feeder

1. Open the feeder guard and pull out the paper support.

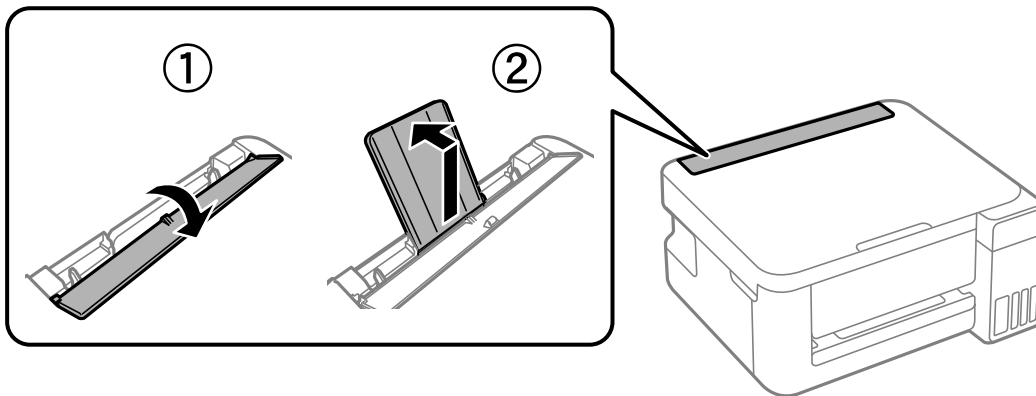

2. Slide the edge guides.

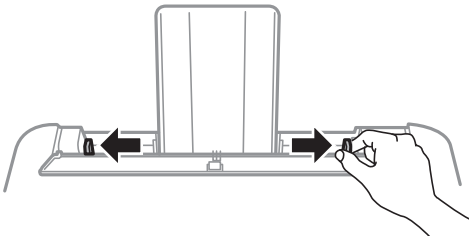

3. Load envelopes short edge first at the center of the paper support with the flap facing down.

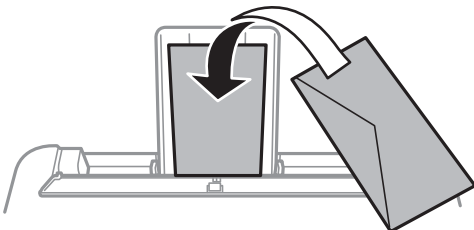

Important:

Do not load more than the maximum number of sheets specified for the envelopes.

- Slide the edge guides to the edges of the envelopes.

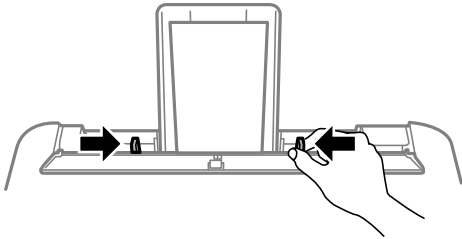

- Tilt the feeder guard until part (A) is not touching the envelopes.

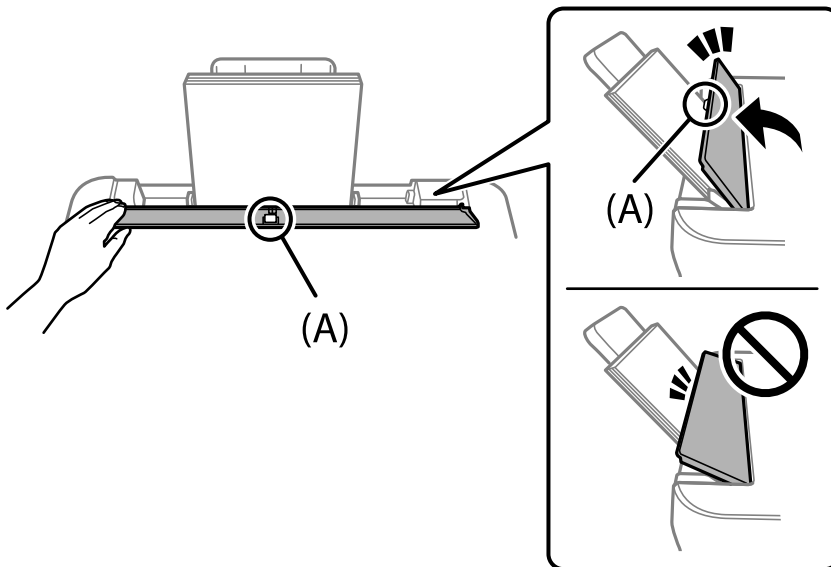

! **Important:**

- Do not place objects on the feeder guard. Doing so may prevent paper from feeding.
- The feeder guard is designed to stop halfway to prevent paper feed problems. Tilt it until it stops.

- Select the paper size and paper type.
- Slide out the output tray.

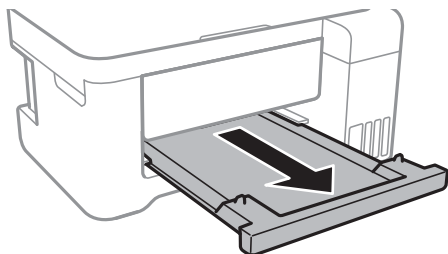

Note:

Return the remaining paper to its package. If you leave it in the printer, the paper may curl or the print quality may decline.

Related Information

- ➔ [“Available Paper and Capacities” on page 168](#)
- ➔ [“Unavailable Paper Types” on page 171](#)

Loading Pre-punched Paper

Load paper at the center arrow mark of the paper support with the printable side facing up.

Load a single sheet of defined size plain paper with binding holes at the left or right. Adjust the print position of your file to avoid printing over the holes.

Automatic 2-sided printing is not available for pre-punched paper.

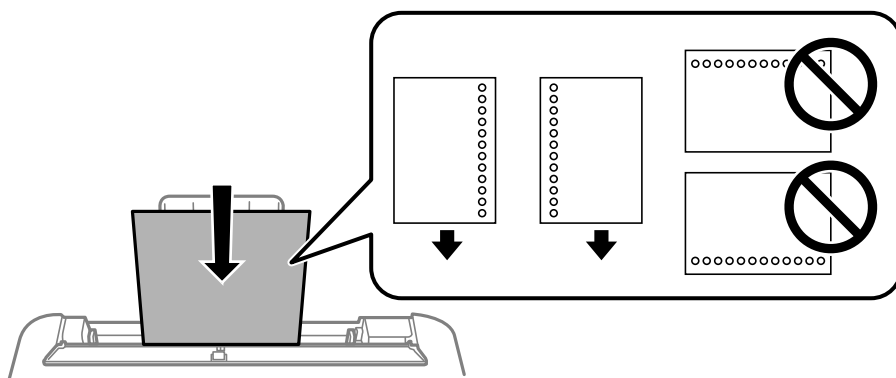

Loading Long Papers

When loading paper longer than legal size, store the paper support and the output tray, and then flatten the leading edge of the paper.

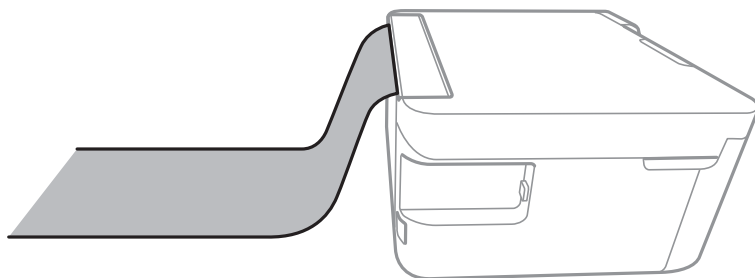

Related Information

- ➔ [“Available Paper and Capacities” on page 168](#)
- ➔ [“Unavailable Paper Types” on page 171](#)

Placing Originals

Placing Originals on the Scanner Glass.34

Placing Originals on the Scanner Glass

1. Open the document cover.

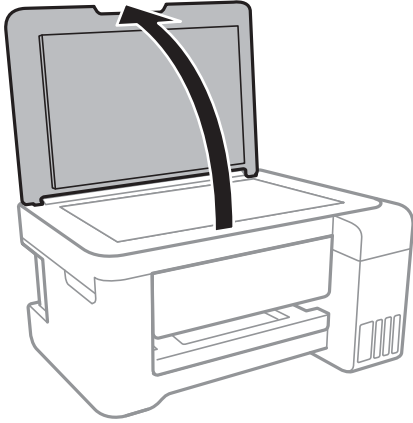

2. Remove any dust or stains on the surface of the scanner glass using a soft, dry, clean cloth.

Note:

If there is any trash or dirt on the scanner glass, the scanning range may expand to include it, so the image of the original may be displaced or reduced.

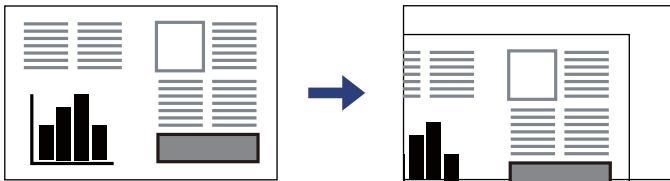

3. Place the original face-down and slide it to the corner mark.

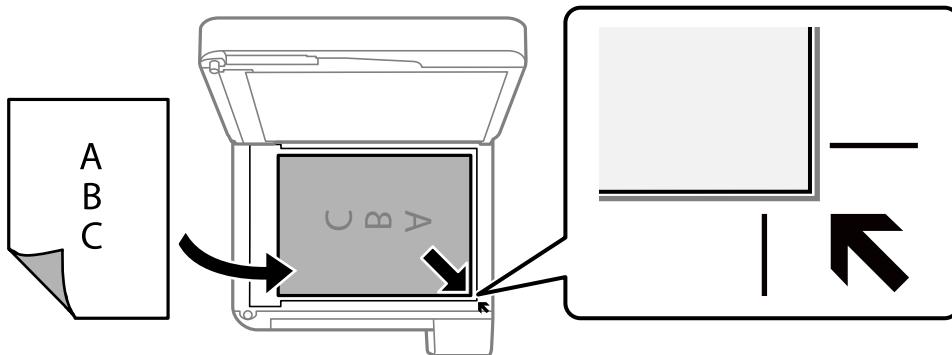

4. Close the cover gently.

! Important:

- When placing bulky originals such as books, prevent exterior light from shining directly onto the scanner glass.
- Do not apply too much force to the scanner glass or the document cover. Otherwise, they may be damaged.

5. Remove the originals after scanning.

Note:

If you leave the originals on the scanner glass for a long time, they may stick to the surface of the glass.

Related Information

➔ [“Scanner Specifications” on page 183](#)

Printing

Printing Documents.	37
Printing on Envelopes.	54
Printing Web Pages.	55
Printing Using a Cloud Service.	56

Printing Documents

Printing from a Computer

This section explains how to print a document from your computer using Windows as an example. On Mac OS, the procedure may be different or some features may not be supported.

Printing Using Easy Settings

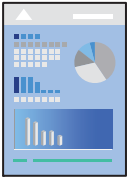

Note:

Operations may differ depending on the application. See the application's help for details.

1. Load paper in the printer.
[“Loading Paper in the Rear Paper Feeder” on page 27](#)
2. Open the file you want to print.
3. Select **Print** or **Print Setup** from the **File** menu.
4. Select your printer.

5. Select **Preferences** or **Properties** to access the printer driver window.

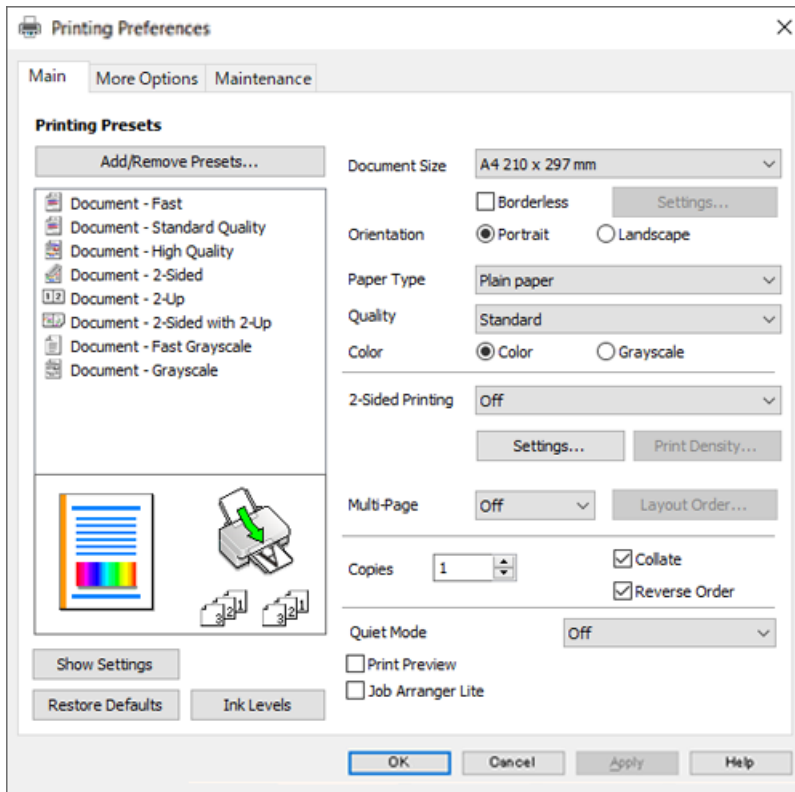

6. Change the settings as necessary.
You can see the online help for explanations of the setting items. Right-clicking an item displays **Help**.
7. Click **OK** to close the printer driver window.
8. Click **Print**.

Related Information

- ➔ [“List of Paper Type” on page 26](#)
- ➔ [“Available Paper and Capacities” on page 168](#)

Adding Printing Presets for Easy Printing

If you create your own preset for frequently used print settings in the printer driver, you can print easily by selecting the preset from the list.

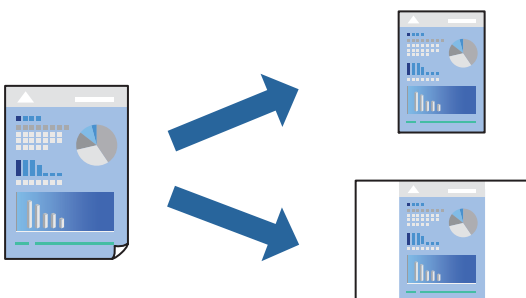

1. On the printer driver's **Main** or **More Options** tab, select the settings you want to include in the preset (such as **Document Size** and **Paper Type**).
2. Click **Add/Remove Presets** in **Printing Presets**.
3. Enter a **Name** and, if necessary, enter a comment.
4. Click **Save**.

Note:

To delete an added preset, click **Add/Remove Presets**, select the preset name you want to delete from the list, and then delete it.

5. Click **Print**.

The next time you want to print using the same settings, select the registered setting name from **Printing Presets**, and click **OK**.

Printing on 2-Sides

The printer driver will automatically print odd pages and even pages separately. When the odd pages have been printed, turn over the paper according to the instructions in the printer driver to print the even pages.

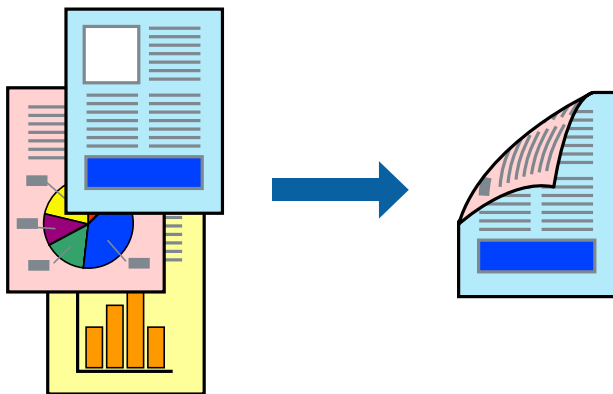

Note:

This feature is not available for borderless printing.

Access the printer driver, and then select the following settings.

Main tab > **2-Sided Printing**

Related Information

- ➔ [“Paper for 2-Sided Printing” on page 170](#)
- ➔ [“Cannot Perform Manual 2-sided Printing \(Windows\)” on page 164](#)

Printing a Booklet

You can also print a booklet that can be created by re-ordering the pages and folding the printout.

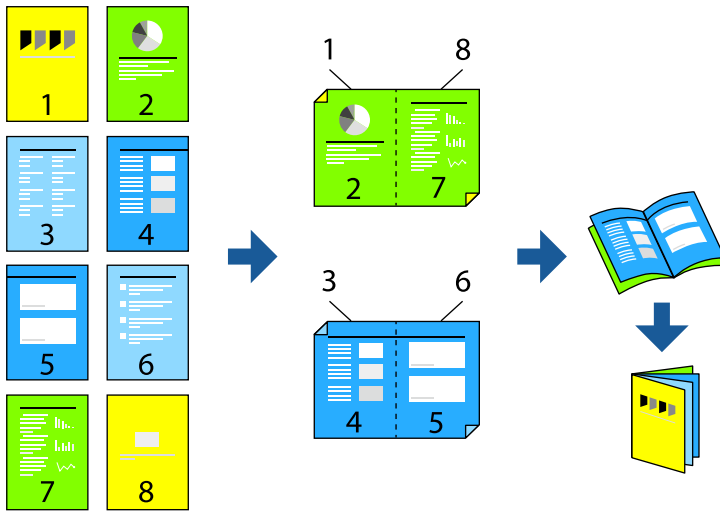

Note:

This feature is not available with borderless printing.

Access the printer driver, and then select the following settings.

On the **Main** tab, select the 2-sided printing method from **2-Sided Printing**, and then select **Settings > Booklet**.

Related Information

- ➔ [“Paper for 2-Sided Printing” on page 170](#)
- ➔ [“Cannot Perform Manual 2-sided Printing \(Windows\)” on page 164](#)

Printing Several Pages on One Sheet

You can print several pages of data on a single sheet of paper.

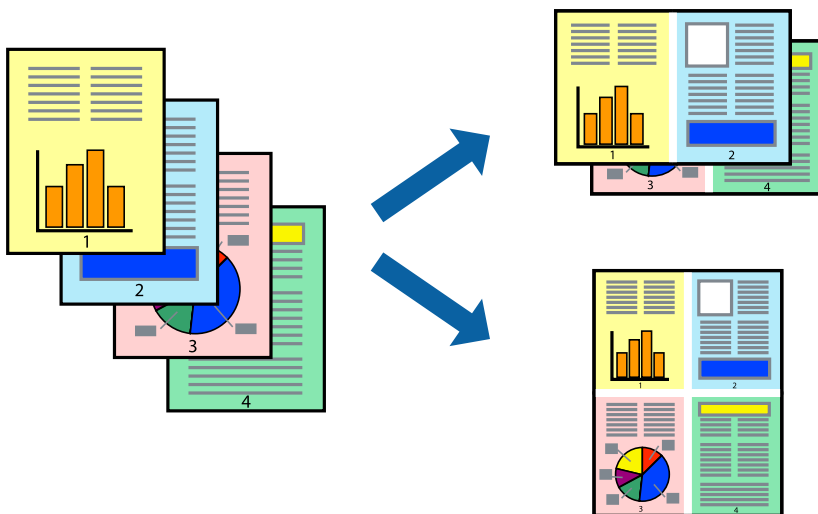

Note:

This feature is not available with borderless printing.

Access the printer driver, and then select the following settings.

Main tab > **Multi-Page** > **2-Up**, etc.

Printing to Fit the Paper Size

You can print to fit the paper size you loaded in the printer.



Note:

This feature is not available with borderless printing.

Access the printer driver, and then select the following settings.

On the **More Options** tab, select **Output Paper**, then select the size of the loaded paper.

Printing a Reduced or Enlarged Document at any Magnification

You can reduce or enlarge the size of a document by a specific percentage.



Note:

This feature is not available with borderless printing.

1. On the printer driver's **More Options** tab, select the document size from the **Document Size** setting.
2. Select the paper size you want to print on from the **Output Paper** setting.
3. Select **Reduce/Enlarge Document, Zoom to**, and then enter a percentage.

Printing One Image on Multiple Sheets for Enlargement (Creating a Poster)

This feature allows you to print one image on multiple sheets of paper. You can create a larger poster by taping them together.

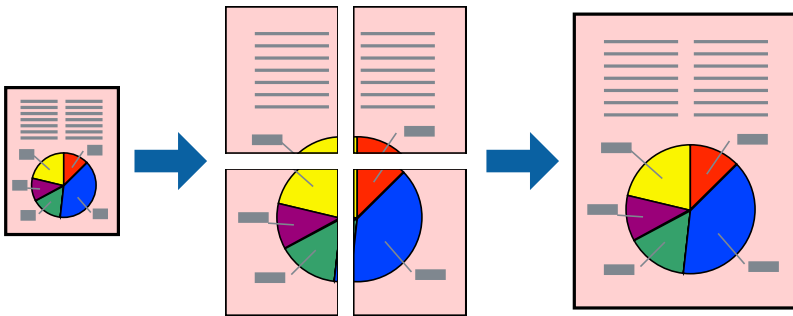

Note:

This feature is not available with 2-sided printing.

Access the printer driver, and then select the following settings.

Main tab > **Multi-Page** > **2x2 Poster**, etc.

Making Posters Using Overlapping Alignment Marks

Here is an example of how to make a poster when **2x2 Poster** is selected, and **Overlapping Alignment Marks** is selected in **Print Cutting Guides**.

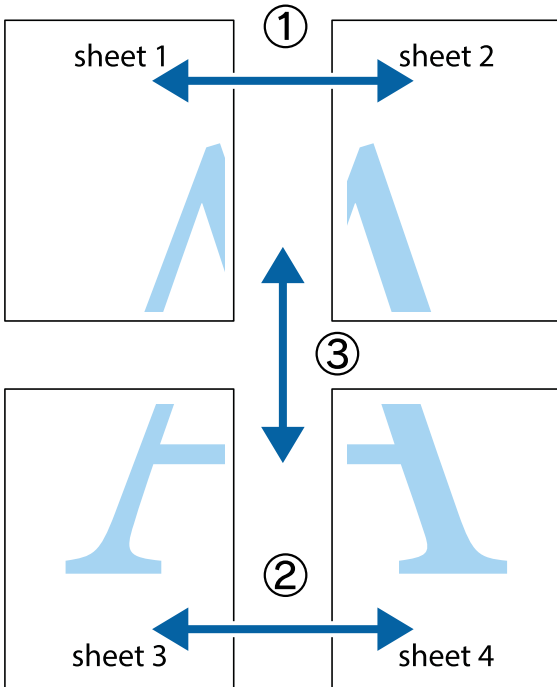

1. Prepare Sheet 1 and Sheet 2. Cut off the margins of Sheet 1 along the vertical blue line through the center of the top and bottom cross marks.

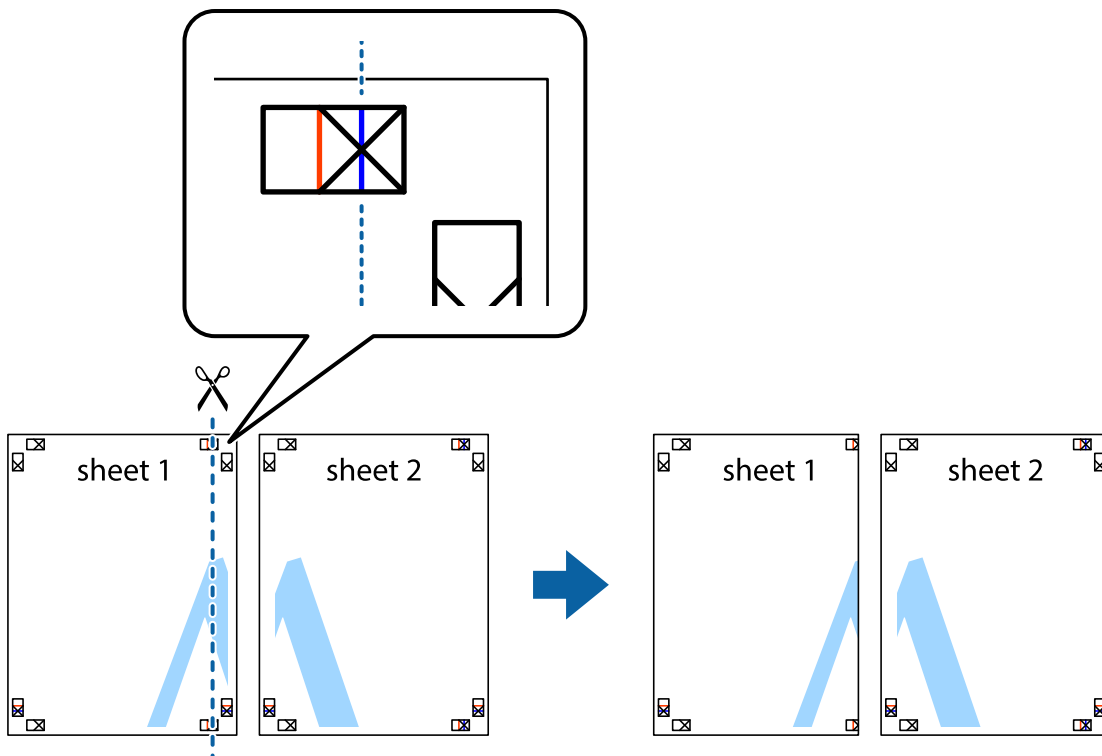

2. Place the edge of Sheet 1 on top of Sheet 2 and align the cross marks, then temporarily tape the two sheets together from the back.

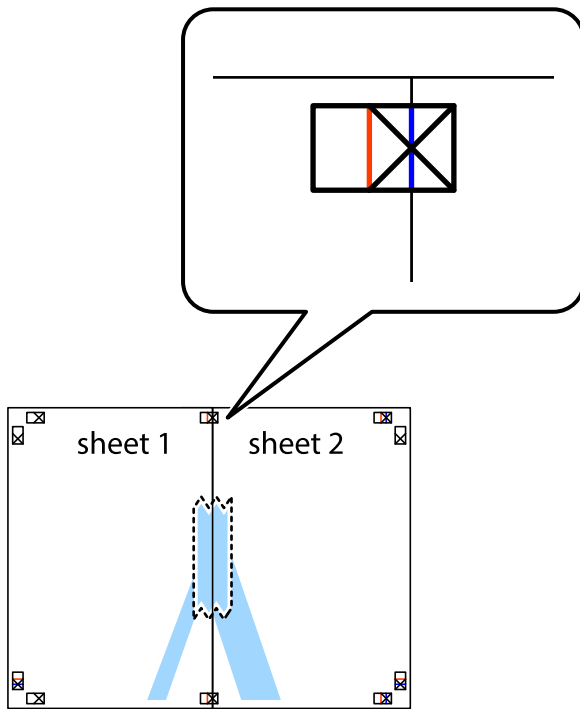

3. Cut the taped sheets in two along the vertical red line through the alignment markers (this time, the line to the left of the cross marks).

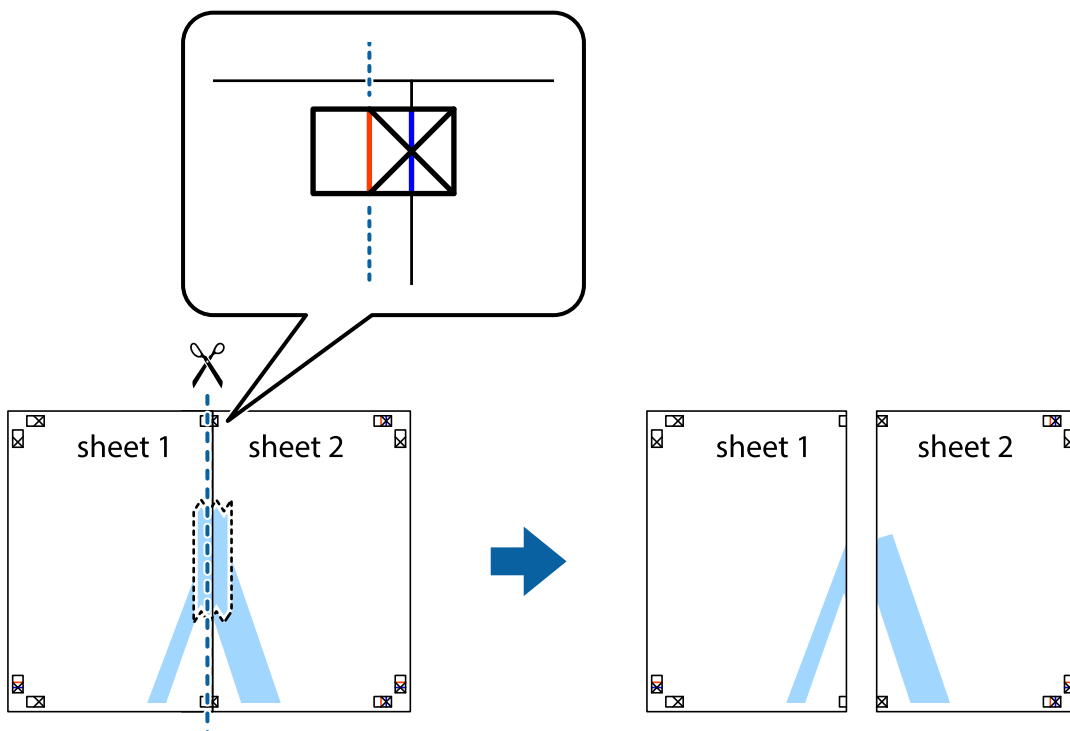

4. Tape the sheets together from the back.

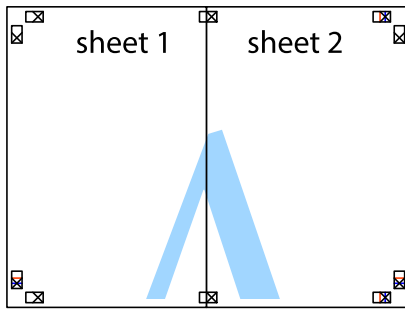

5. Repeat steps 1 to 4 to tape Sheet 3 and Sheet 4 together.
6. Cut off the margins of Sheet 1 and Sheet 2 along the horizontal blue line through the center of the left and right side cross marks.

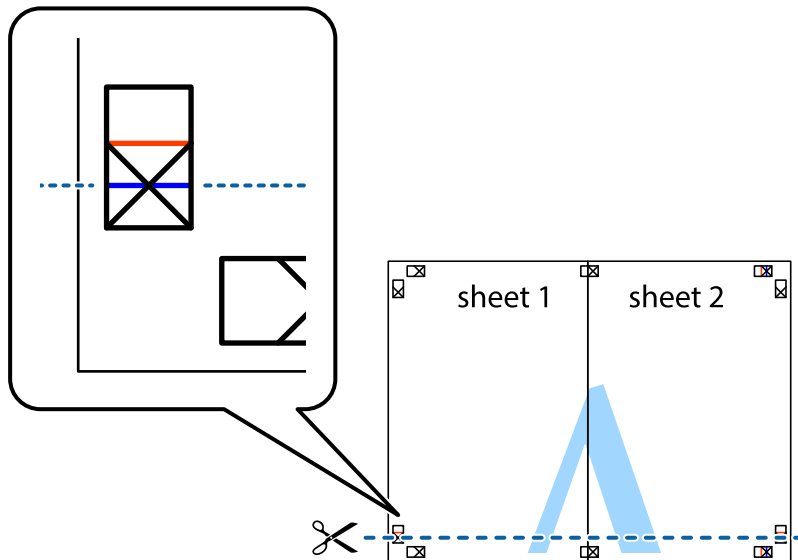

7. Place the edge of Sheet 1 and Sheet 2 on top of Sheet 3 and Sheet 4 and align the cross marks, and then temporarily tape them together from the back.

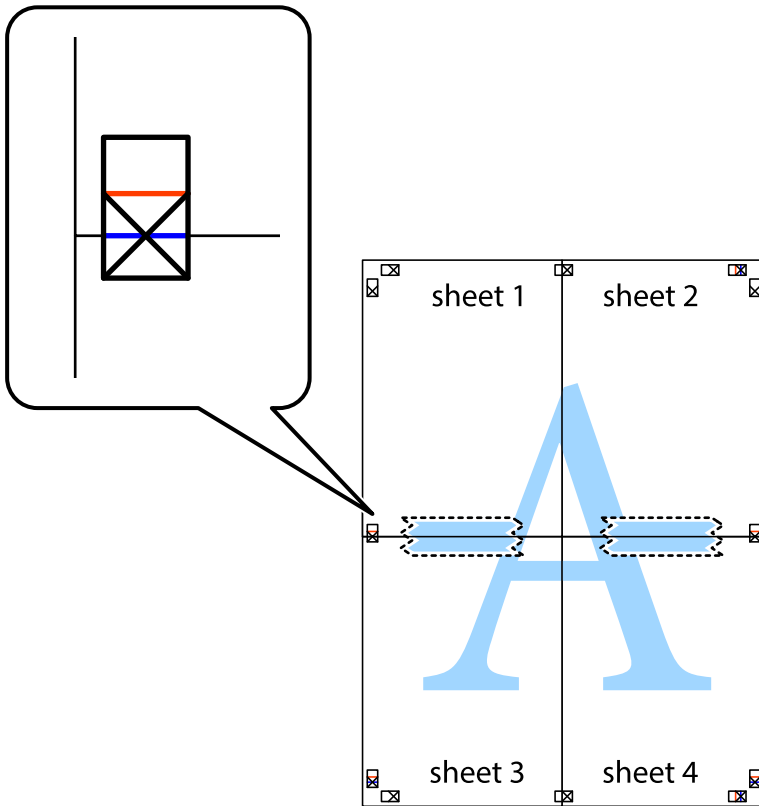

- Cut the taped sheets in two along the horizontal red line through the alignment markers (this time, the line above the cross marks).

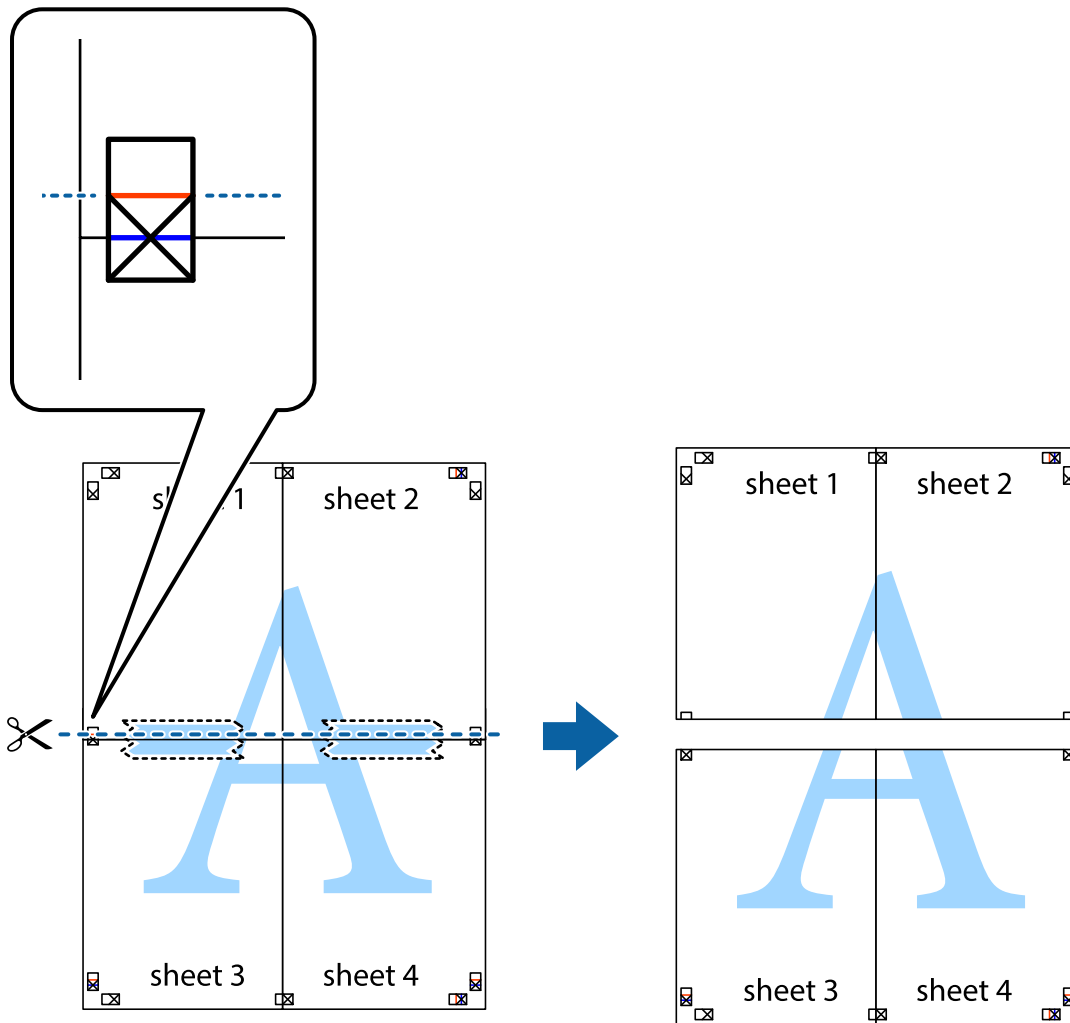

- Tape the sheets together from the back.

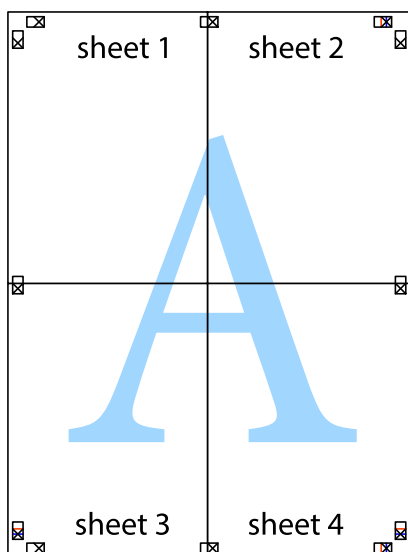

10. Cut off the remaining margins along the outer guide.

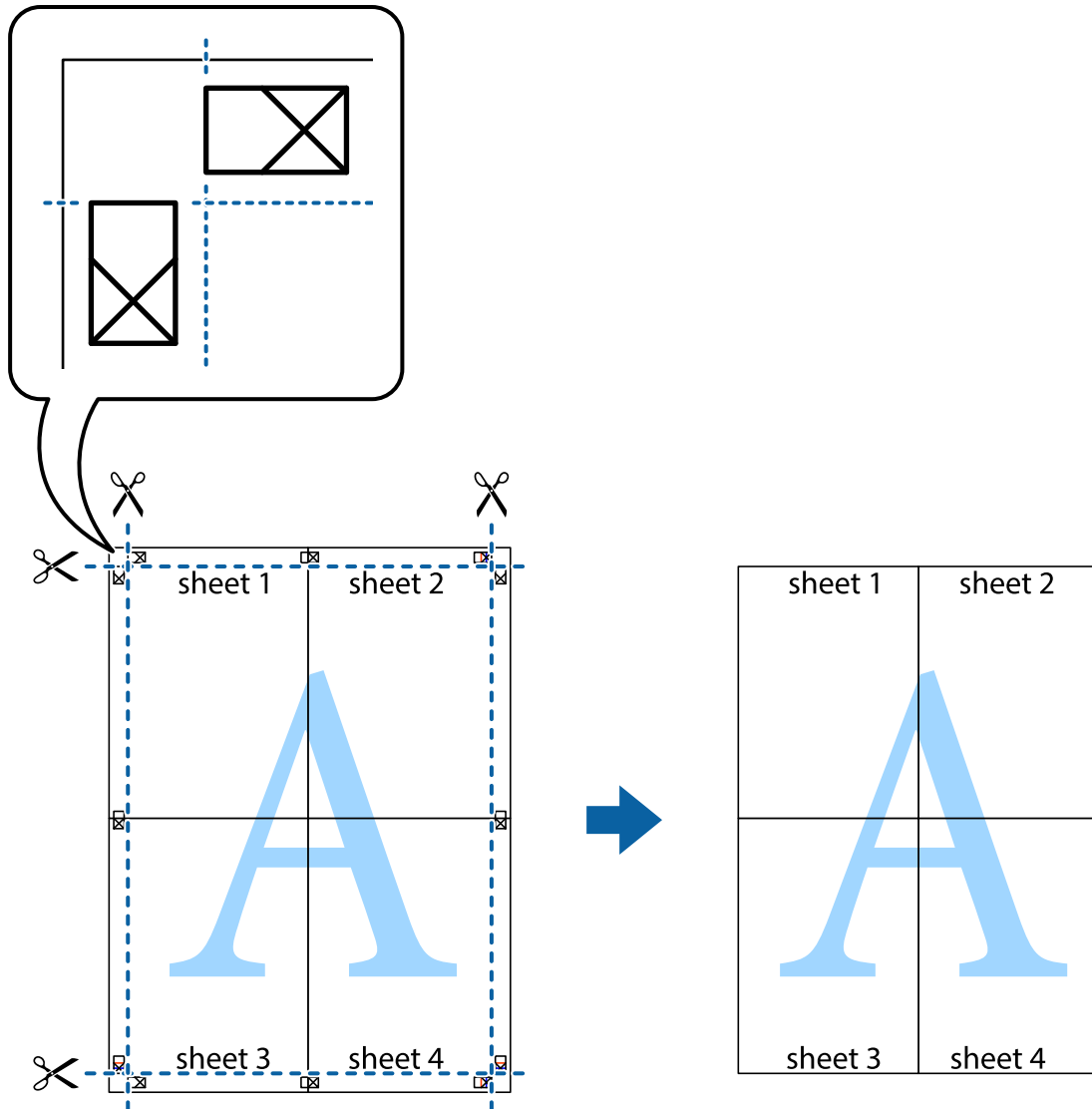

Printing with a Header and Footer

You can print information such as a user name and printing date in headers or footers.

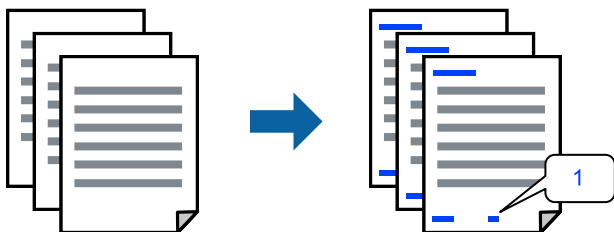

Access the printer driver, and then select the following settings.

More Options tab > **Watermark Features** > **Header/Footer**

Printing an Anti-Copy Pattern

You can print an anti-copy pattern on your printouts. When printing, the letters themselves are not printed and the entire print is screen-toned lightly. The hidden letters appear when photocopied to easily distinguish the original from the copies.



Anti-Copy Pattern is available under the following conditions:

- Paper Type: Plain paper, Letterhead
- Quality: Standard
- 2-Sided Printing: Off
- Borderless: Not selected
- Color Correction: Automatic

Access the printer driver, and then make the following settings.

More Options tab > **Watermark Features** > **Anti-Copy Pattern**

Printing a Watermark

You can print a watermark such as "Confidential" on your printouts. You can also add your own watermark.



Note:

This feature is not available with borderless printing.

Access the printer driver, and then select the following settings.

More Options tab > **Watermark Features** > **Watermark**

Printing Multiple Files Together

Job Arranger Lite allows you to combine several files created by different applications and print them as a single print job. You can specify the print settings for combined files, such as multi-page layout, and 2-sided printing.

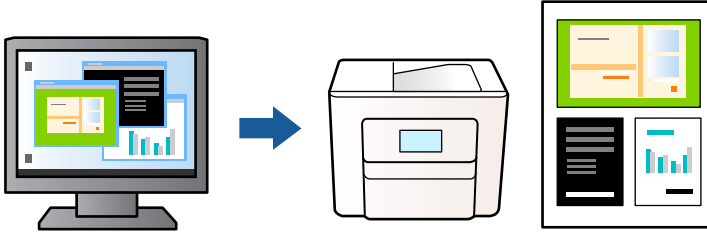

1. On the printer driver's **Main** tab, select **Job Arranger Lite**, and then click **OK**.
2. Click **Print**.
When you start printing, the Job Arranger Lite window is displayed.
3. With the Job Arranger Lite window opened, open the file that you want to combine with the current file, and then repeat the above steps.
4. When you select a print job added to Print Project in the Job Arranger Lite window, you can edit the page layout.
5. Click **Print** from the **File** menu to start printing.

Note:

If you close the Job Arranger Lite window before adding all the print data to the Print Project, the print job you are currently working on is canceled. Click **Save** from the **File** menu to save the current job. The extension of the saved files is ".ecl".

To open a Print Project, click **Job Arranger Lite** on the printer driver's **Maintenance** tab to open the Job Arranger Lite window. Next, select **Open** from the **File** menu to select the file.

Printing Using the Color Universal Print Feature

You can enhance the visibility of texts and images in printouts.

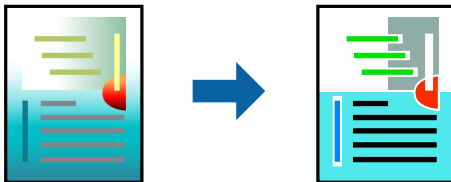

Color Universal Print is only available when the following settings are selected.

- Paper Type: Plain paper, Letterhead
- Quality: Standard or a higher quality
- Color: Color
- Applications: Microsoft® Office 2007 or later
- Text Size: 96 pts or smaller

Access the printer driver, and then make the following settings.

More Options tab > **Color Correction** > **Image Options** > **Color Universal Print**

Adjusting the Print Color

You can adjust the colors used in the print job. These adjustments are not applied to the original data.

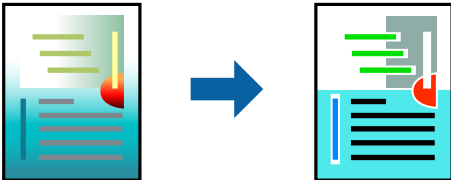

PhotoEnhance produces sharper images and more vivid colors by automatically adjusting the contrast, saturation, and brightness of the original image data.

Note:

PhotoEnhance adjusts the color by analyzing the location of the subject. Therefore, if you have changed the location of the subject by reducing, enlarging, cropping, or rotating the image, the color may change unexpectedly. Selecting the borderless setting also changes the location of the subject resulting in changes in color. If the image is out of focus, the tone may be unnatural. If the color is changed or becomes unnatural, print in a mode other than **PhotoEnhance**.

1. On the printer driver's **More Options** tab, select the method of color correction from the **Color Correction** setting.
 - Automatic: This setting automatically adjusts the tone to match the paper type and print quality settings.
 - Custom: Click **Advanced**, you can make your own settings.
2. Select other settings on the **Main** and **More Options** tabs as necessary, and then click **OK**.
3. Click **Print**.

Printing to Emphasize Thin Lines

You can thicken thin lines that are too thin to print.

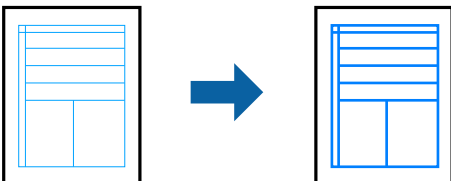

Access the printer driver, and then select the following settings.

More Options tab > **Color Correction** > **Image Options** > **Emphasize Thin Lines**

Printing Clear Bar Codes

If printed bar codes cannot be read correctly, you can print clearly using reduced ink bleeding. Only enable this feature if the bar code you printed cannot be scanned. Deblurring may not always be possible depending on the circumstances.

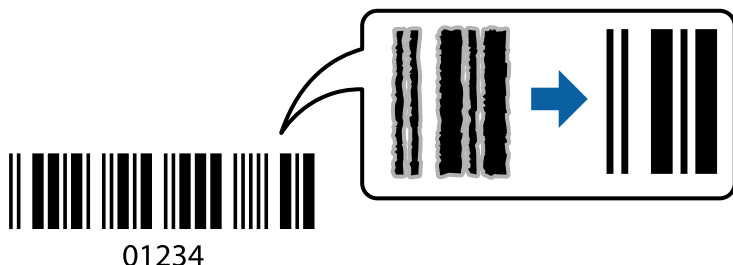

You can use this feature for the following paper types and print quality.

Plain paper, Envelope: Standard

Access the printer driver, and then make the following settings.

Maintenance tab > Extended Settings > Barcode mode

Printing Documents from Mobile Devices

You can print documents from a mobile device.

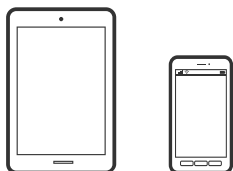

Printing Using Epson Smart Panel

Epson Smart Panel is an application that allows you to perform printer operations easily including printing, copying, or scanning from a mobile device. You can connect the printer and mobile device over a wireless network, check the ink levels and printer status, and check for solutions if an error occurs. You can also copy easily by registering a copy favorite.



Install Epson Smart Panel from the following URL or QR code.

<https://support.epson.net/smpdl/>



Start Epson Smart Panel, and then select the print menu on the home screen.

Printing Documents Using AirPrint

AirPrint enables instant wireless printing from iPhone, iPad, iPod touch, and Mac without the need to install drivers or download software.



Note:

If you disabled paper configuration messages on your printer control panel, you cannot use AirPrint. See the link below to enable the messages, if necessary.

1. Set up your printer for wireless printing. See the link below.
<https://epson.sn>
2. Connect your Apple device to the same wireless network that your printer is using.
3. Print from your device to your printer.

Note:

For details, see the AirPrint page on the Apple website.

Related Information

➔ [“Cannot Print Even Though a Connection has been Established \(iOS\)” on page 120](#)

Printing Using Mopria Print Service

Mopria Print Service enables instant wireless printing from Android smartphones or tablets.

Install Mopria Print Service from Google Play.



For more details, access the Mopria Web site at <https://mopria.org>.

Printing Using Epson Print Enabler

You can wirelessly print your documents, emails, photos, and web pages right from your Android phone or tablet (Android v7.0 or later). With a few taps, your Android device will discover an Epson printer that is connected to the same wireless network.

Search for and install Epson Print Enabler from Google Play.

Go to **Settings** on your Android device, select **Printing**, and then enable Epson Print Enabler. From an Android application such as Chrome, tap the menu icon and print whatever is on the screen.

Note:

*If you do not see your printer, tap **All Printers** and select your printer.*

Printing on Envelopes

Printing on Envelopes from a Computer (Windows)

1. Load envelopes in the printer.
[“Loading Envelopes in the Rear Paper Feeder” on page 30](#)
2. Open the file you want to print.
3. Access the printer driver window.
4. Select the envelope size from **Document Size** on the **Main** tab, and then select **Envelope** from **Paper Type**.
5. Select other settings on the **Main** and **More Options** tabs as necessary, and then click **OK**.
6. Click **Print**.

Printing on Envelopes from a Computer (Mac OS)

1. Load envelopes in the printer.
[“Loading Envelopes in the Rear Paper Feeder” on page 30](#)
2. Open the file you want to print.
3. Select **Print** from the **File** menu or another command to access the print dialog.
4. Select the size as the **Paper Size** setting.
5. Select **Print Settings** from the pop-up menu.
6. Select **Envelope** as the **Media Type** setting.
7. Set the other items as necessary.
8. Click **Print**.

Printing Web Pages

Printing Web Pages from a Computer

Epson Photo+ allows you to display web pages, crop to a specified area, and then edit and print them. See the application's help for details.

Printing Web Pages from Mobile Devices

Install Epson Smart Panel from the following URL or QR code.

<https://support.epson.net/smpdl/>



Open the web page you want to print in your web browser app. Tap **Share** from the menu of the web browser application, select **Smart Panel**, and then start printing.

Printing Using a Cloud Service

By using Epson Connect service available on the Internet, you can print from your smartphone, tablet PC, or laptop, anytime and practically anywhere. To use this service, you need to register the user and the printer in Epson Connect.

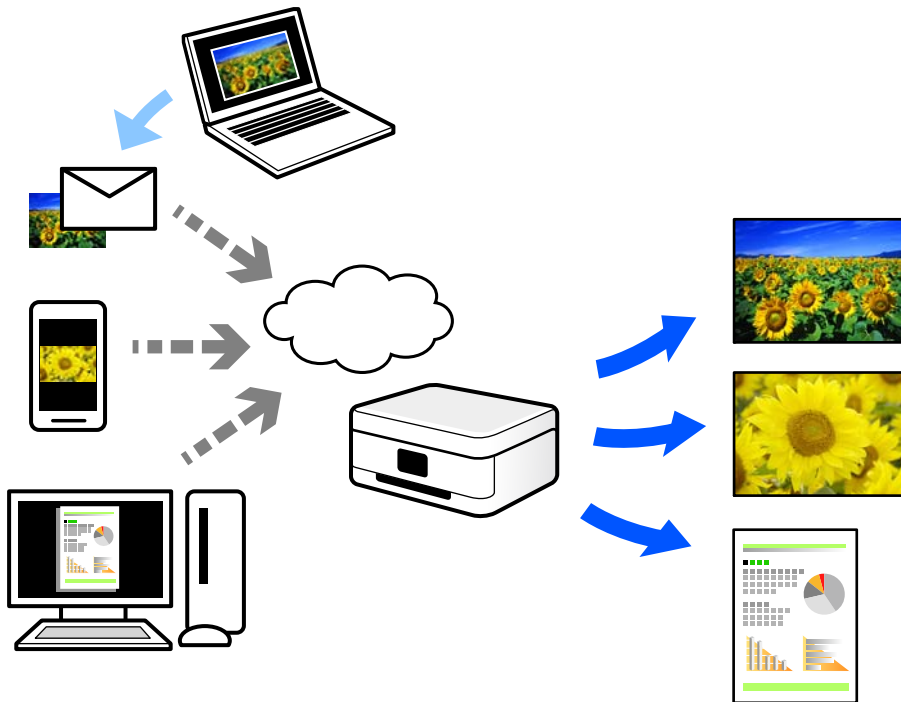

The features available on the Internet are as follows.

Email Print

When you send an email with attachments such as documents or images to an email address assigned to the printer, you can print that email and the attachments from remote locations such as your home or office printer.

Epson Smart Panel

This Application is for iOS and Android, and allows you to print or scan from a smart phone or tablet. You can print documents, images, and web sites by sending them directly to a printer on the same wireless LAN.

Remote Print Driver

This is a shared driver supported by Remote Print Driver. When printing using a printer in a remote location, you can print by changing the printer on the usual applications window.

See the Epson Connect web portal for details on how to setup or print.

<https://www.epsonconnect.com/>

<http://www.epsonconnect.eu> (Europe only)



Copying

Available Copying Methods.	58
More Menu Options for Copying.	62

Available Copying Methods

Place the originals on the scanner glass, and then select the **Copy** menu on the home screen.

Copying Originals

This section explains the steps for copying originals in color or monochrome.

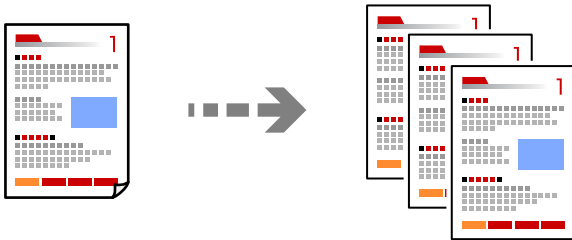

1. Load paper in the printer.
[“Loading Paper in the Rear Paper Feeder” on page 27](#)
2. Place the originals.
[“Placing Originals on the Scanner Glass” on page 34](#)

3. Select **Copy** on the home screen.

To select an item, use the ◀▶ buttons, and then press the OK button.

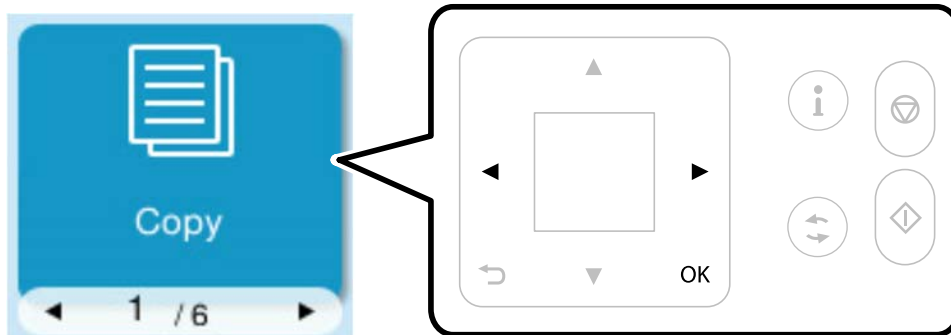

4. Select **Color** or **B&W**.
5. Set the number of copies as necessary.
6. Press the ◊ button.

Note:

The color, size, and border of the copied image are slightly different from the original.

Copying on 2-Sides

Copy multiple originals on both sides of the paper.



Copy > More > Print Settings > Settings > 2-Sided

Copying by Enlarging or Reducing

You can copy originals at a specified magnification.

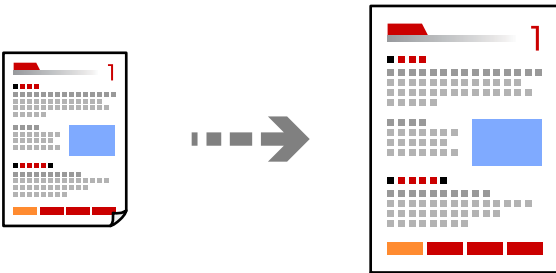

Copy > More > Print Settings > Settings > Reduce/Enlarge

Related Information

➔ [“More Menu Options for Copying” on page 62](#)

Copying Multiple Originals onto One Sheet

You can copy the multiple originals onto a single sheet.

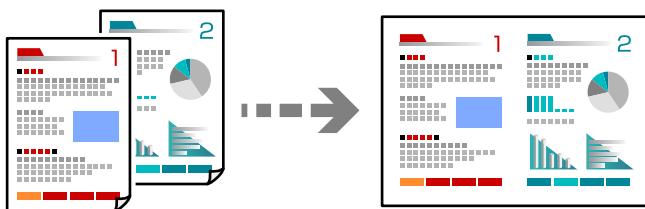

Copy > 2-upColor

When placing originals, place them face-down as shown below.

❑ Copying originals horizontally

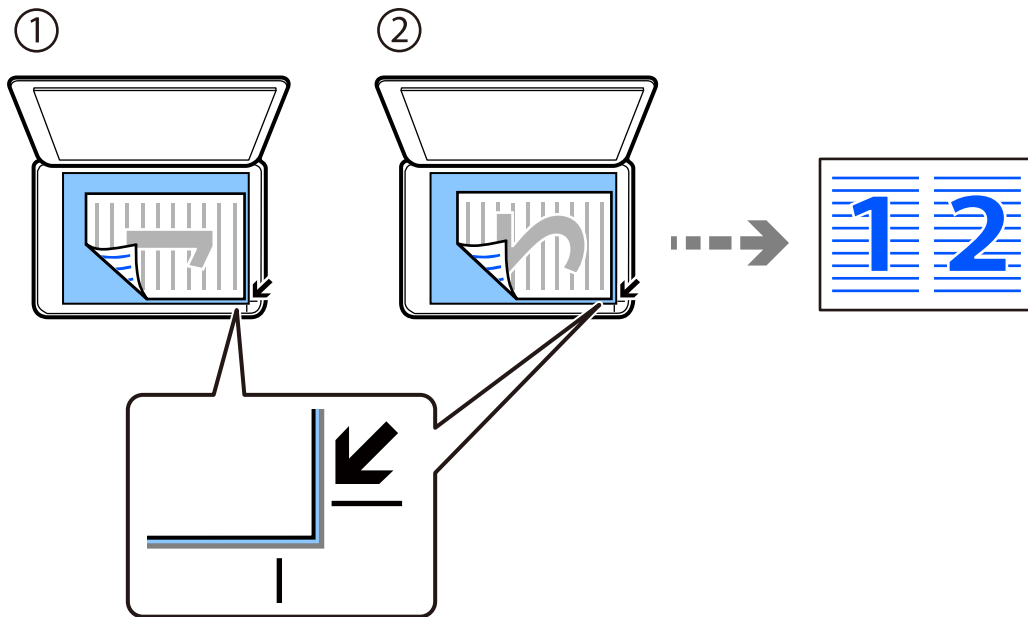

❑ Copying originals vertically

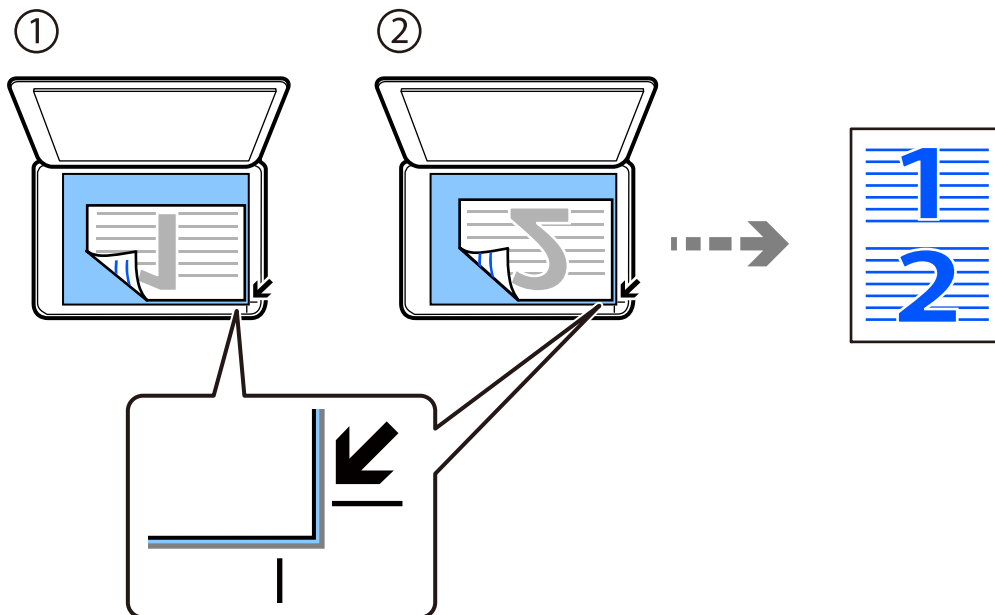

Note:

You can also select **More** to change the settings. See the related information below for explanations of the setting items.

Related Information

➔ [“More Menu Options for Copying” on page 62](#)

Copying ID card

Scans both sides of an ID card and copies onto one side of A4 size paper.

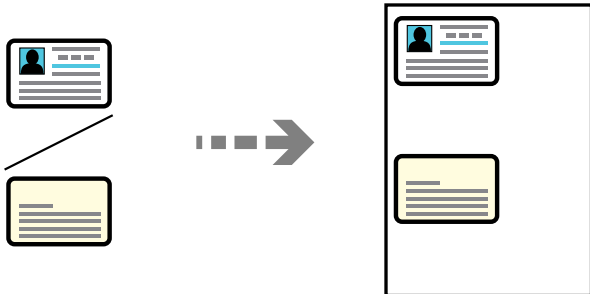

Copy > More > Print Settings > Settings > ID Card Copy

Place the original face-down and slide it to the corner mark. Place an ID card 5 mm away from the corner mark of the scanner glass.

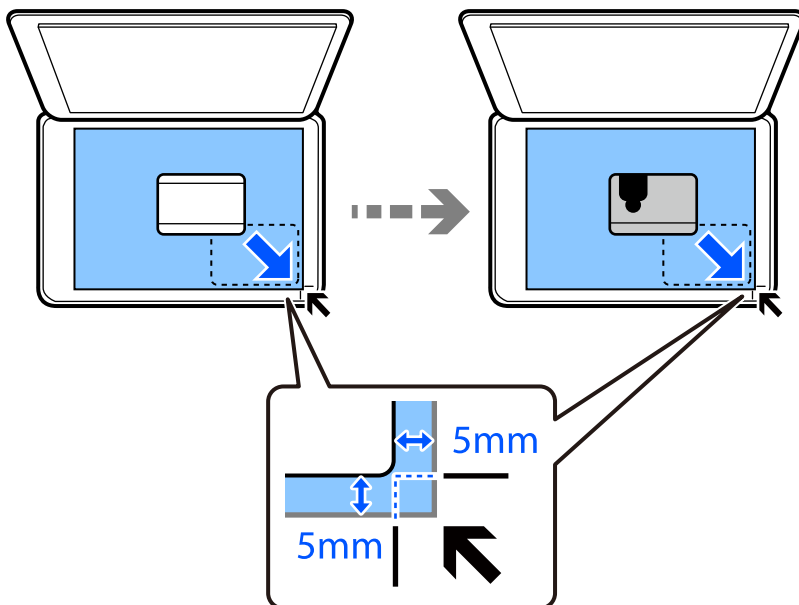

Related Information

➔ [“More Menu Options for Copying” on page 62](#)

Copying Without Margins

Copies without margins around the edges. The image is enlarged a little to remove margins from the edges of the paper.

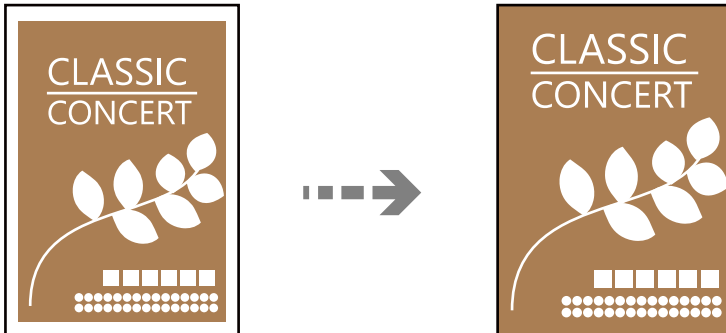

Copy > More > Print Settings > Settings > Borderless Copy

More Menu Options for Copying

You can make these settings from **Copy > More** on the home screen.

The number of copies:

Enter the number of copies.

2-Sided:

Select 2-sided layout.

1→1-Sided

Copies one side of an original onto a single side of paper.

1→2-Sided

Copies two single-sided originals onto both sides of a single sheet of paper. Select the orientation of your original and the binding position of the paper.

Print Settings:

The print settings screen is displayed. To change the settings, press the ▼ button.

Density:

Increase the level of density when the copying results are faint. Decrease the level of density when ink smears.

Paper Setting:

Select the paper size and the paper type you loaded.

Reduce/Enlarge:

Configures the magnification ratio for enlargement or reduction. Select the magnification from the menu according to the paper and original you want to print.

Auto Fit :

Detects the scan area and automatically enlarges or reduces the original to fit to the paper size you selected.

Original Size:

Select the size of your original. When copying non-standard size originals, select the size closest to your original.

Multi-Page:

Select the copy layout.

Single Page

Copies a single-sided original onto a single sheet.

2-up

Copies two single-sided originals onto a single sheet in 2-up layout. Select the layout order and the orientation of your original.

Quality:

Select the quality for copying. Selecting **High** provides higher quality printing, but the printing speed may be slower.

ID Card Copy:

Select to scan both sides of an ID card and copies onto one side of a paper.

Borderless Copy:

Select to copy without margins around the edges. The image is enlarged a little to remove margins from the edges of the paper. Select how much to enlarge in the **Expansion** setting.

Scanning

Basic Information on Scanning.	65
Scanning Originals to a Computer.	67
Scanning Using WSD.	69
Scanning Originals to a Mobile Device.	72
Scanning Using Mopria Scan.	72
Advanced Scanning.	72

Basic Information on Scanning

What is a "Scan"?

A "scan" is the process of converting the optical information on paper (such as documents, magazine clippings, photos, and handwritten illustrations) into digital image data.

You can save scanned data as a digital image such as a JPEG or PDF.

You can then print the image, send it by email, or share the image in other ways.

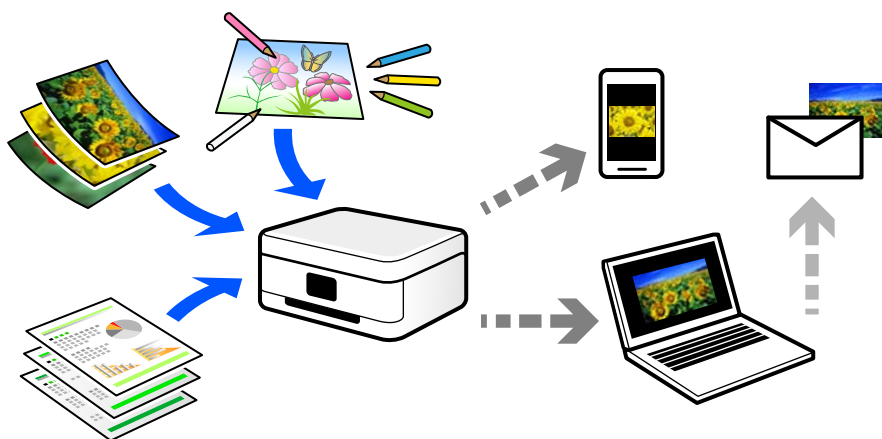

Scanning Uses

You can use scanning in a variety of ways to make your life more convenient.

- By scanning a paper document and turning it into digital data, you can read it on a computer or a mobile device.
- By scanning tickets or flyers into digital data, you can dispose of the originals and reduce clutter.
- By scanning important documents, you can back them up to cloud services or another storage medium, just in case they get lost.
- You can send the scanned photos or documents to friends by email.
- By scanning hand-drawn illustrations, you can share them on social media at a much higher quality than by just taking a photo on your mobile device.
- By scanning your favorite pages from newspapers or magazines, you can save them and dispose of the originals.

Available Scanning Methods

You can use any of the following methods to scan using this printer.

Scanning to a Computer

There are two methods of scanning originals to a computer; scanning using the printer's control panel, and scanning from the computer.

You can scan easily from the control panel.

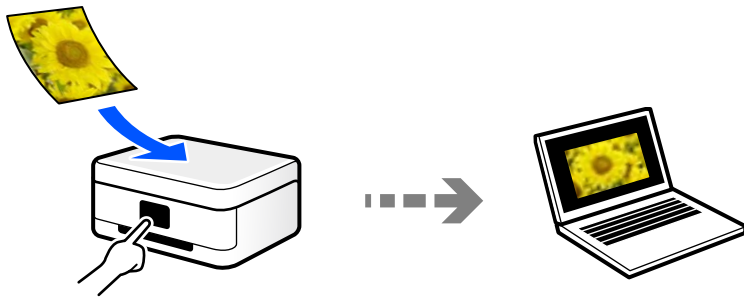

Use the scanning application Epson ScanSmart to scan from the computer. You can edit images after scanning.

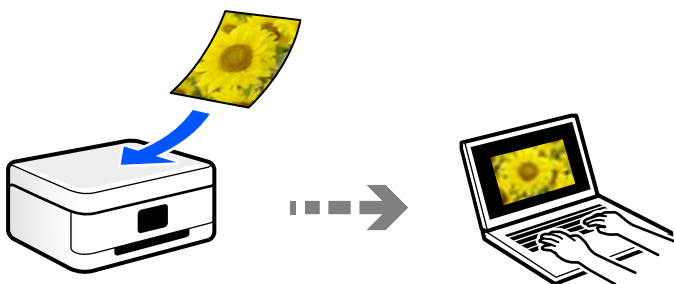

Scanning Using WSD

You can save the scanned image to a computer connected to the printer, using the WSD feature. If you are using Windows 7, you need to select WSD settings on your computer before scanning.

Scanning Directly from Mobile Devices

You can save scanned images directly to a mobile device by using the Epson Smart Panel application.

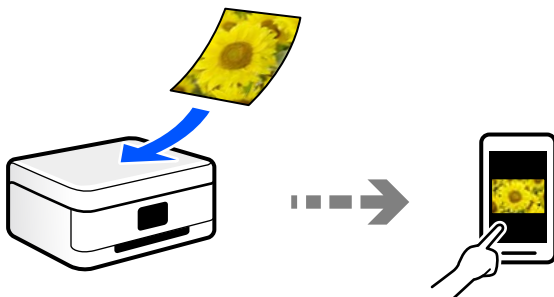

Recommended File Formats

Generally speaking, the JPEG format is suitable for photos while the PDF format is suitable for documents. See the following descriptions to choose the best format for what you want to do.

File Format	Description
JPEG (.jpg)	<p>A file format that allows you to compress the data to be saved. If the compression ratio is high, the image quality declines, and you cannot convert the image back to the original quality.</p> <p>This is the standard image format for digital cameras. This format is suitable for images that have many colors.</p>
PDF (.pdf)	<p>A general file format that can be used across different operating systems and provides the same level of screen display and print result.</p> <p>You can view PDF files using dedicated PDF reading software or in web browsers.</p>

Recommended Resolutions

Resolution indicates the number of pixels (smallest area of an image) for each inch (25.4 mm), and is measured in dpi (dots per inch). The advantage of increasing the resolution is that the details in the image improve. However, it can also have the following disadvantages.

- The file size becomes large
(When you double the resolution, the file size becomes about four times larger.)
- Scanning, saving, and reading the image takes a long time
- The image becomes too large to fit the display or print on the paper

See the table and set the appropriate resolution for the purpose of your scanned image.

Purpose	Resolution (Reference)
Displaying on a computer Sending by email	Up to 200 dpi
Printing	200 to 300 dpi

Scanning Originals to a Computer

There are two methods of scanning originals to a computer; scanning using the printer's control panel, and scanning from the computer.

Scanning from the Control Panel

To use this feature, make sure the following applications are installed on your computer.

OS	Application Required for Use	Checking for Installed Applications
Windows 11	<input type="checkbox"/> Epson ScanSmart <input type="checkbox"/> Epson Scan 2	Click the start button, and then check the All apps > Epson Software folder > Epson ScanSmart , and the EPSON folder > Epson Scan 2 .
Windows 10	<input type="checkbox"/> Epson ScanSmart <input type="checkbox"/> Epson Scan 2	Click the start button, and then check the Epson Software folder > Epson ScanSmart , and the EPSON folder > Epson Scan 2 .

OS	Application Required for Use	Checking for Installed Applications
Windows 8.1 / Windows 8	<input type="checkbox"/> Epson ScanSmart <input type="checkbox"/> Epson Scan 2	Enter the application name in the search charm, and then check the displayed icon.
Windows 7	<input type="checkbox"/> Epson ScanSmart <input type="checkbox"/> Epson Scan 2	Click the start button, and then select All Programs . Next, check the Epson Software folder > Epson ScanSmart , and the EPSON folder > Epson Scan 2 .
OS X El Capitan (10.11) or later	<input type="checkbox"/> Epson ScanSmart <input type="checkbox"/> Epson Scan 2	Select Go > Applications > Epson Software .
OS X Yosemite (10.10) / OS X Mavericks (10.9.5)	<input type="checkbox"/> Epson Event Manager <input type="checkbox"/> Epson Scan 2	Select Go > Applications > Epson Software .

If the application is not installed, download and install it from the Epson website.

www.epson.com

Note:

For Windows Server operating systems, you can not use this feature.

- Place the originals.
 “Placing Originals on the Scanner Glass” on page 34
- Select **Scan to Computer** on the control panel.

To select an item, use the ◀▶ buttons, and then press the OK button.

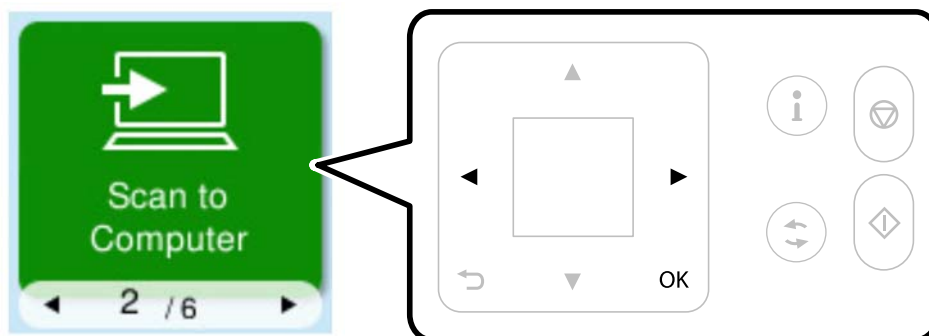

- Select how to save the scanned image to a computer.
 - Preview on Computer (Windows, or OS X El Capitan (10.11) or later): Previews the scanned image on a computer before saving images.
 - Save as JPEG: Saves the scanned image in JPEG format.
 - Save as PDF: Saves the scanned image in PDF format.
- If the **Select Computer** screen is displayed, select a computer on which to save the scanned images.
- Press the ◊ button.

When using Windows, or OS X El Capitan (10.11) or later: Epson ScanSmart automatically starts on your computer, and scanning starts.

Note:

- See the *Epson ScanSmart help* for detailed operation information for the software. Click **Help** on the *Epson ScanSmart* screen to open the help.
- The color, size, and border of the scanned image will not be exactly the same as the original.

Scanning from a Computer

You can scan from a computer by using Epson ScanSmart.

This application allows you to scan documents and photos easily, and then save the scanned images in simple steps.

Note:

Windows Server operating systems are not supported.

1. Place the originals.

[“Placing Originals on the Scanner Glass” on page 34](#)

2. Start Epson ScanSmart.

- Windows 11

Click the start button, and then select **All apps > Epson Software > Epson ScanSmart**.

- Windows 10

Click the start button, and then select **Epson Software > Epson ScanSmart**.

- Windows 8.1/Windows 8

Enter the application name in the search charm, and then select the displayed icon.

- Windows 7

Click the start button, and then select **All Programs > Epson Software > Epson ScanSmart**.

- Mac OS

Select **Go > Applications > Epson Software > Epson ScanSmart**.

3. When the Epson ScanSmart screen is displayed, follow the on-screen instructions to scan.

Note:

Click **Help** to view detailed operation information.

Scanning Using WSD

You can save the scanned image to a computer connected to the printer, using WSD feature.

- This feature is only available for computers running Windows 7 or later.
- If you are using Windows 7, you need to setup your computer in advance using this feature.

[“Setting Up a WSD Port” on page 70](#)

1. Place the originals.

[“Placing Originals on the Scanner Glass” on page 34](#)

2. Select **To WSD** on the control panel.

To select an item, use the ◀▶ buttons, and then press the OK button.

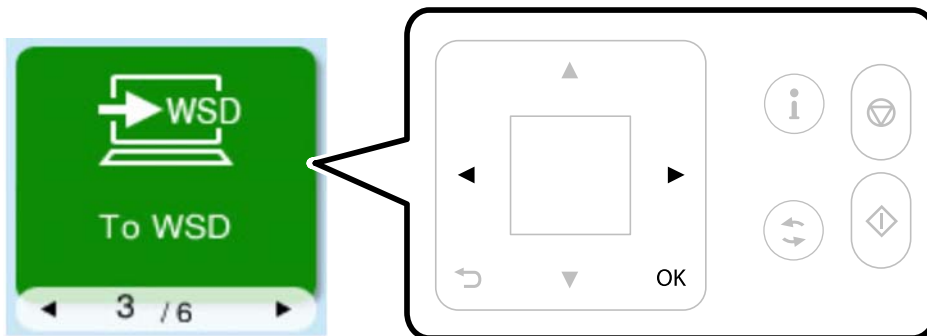

3. Select a computer.
4. Press the ◊ button.

Setting Up a WSD Port

This section explains how to set up a WSD port for Windows 7.

Note:

For Windows 8 or later, the WSD port is set up automatically.

The following is necessary to set up a WSD port.

- The printer and the computer are connected to the network.
- The printer driver is installed on the computer.

1. Turn the printer on.
2. Click start, and then click **Network** on the computer.
3. Right-click the printer, and then click **Install**.
Click **Continue** when the **User Account Control** screen is displayed.

Click **Uninstall** and start again if the **Uninstall** screen is displayed.

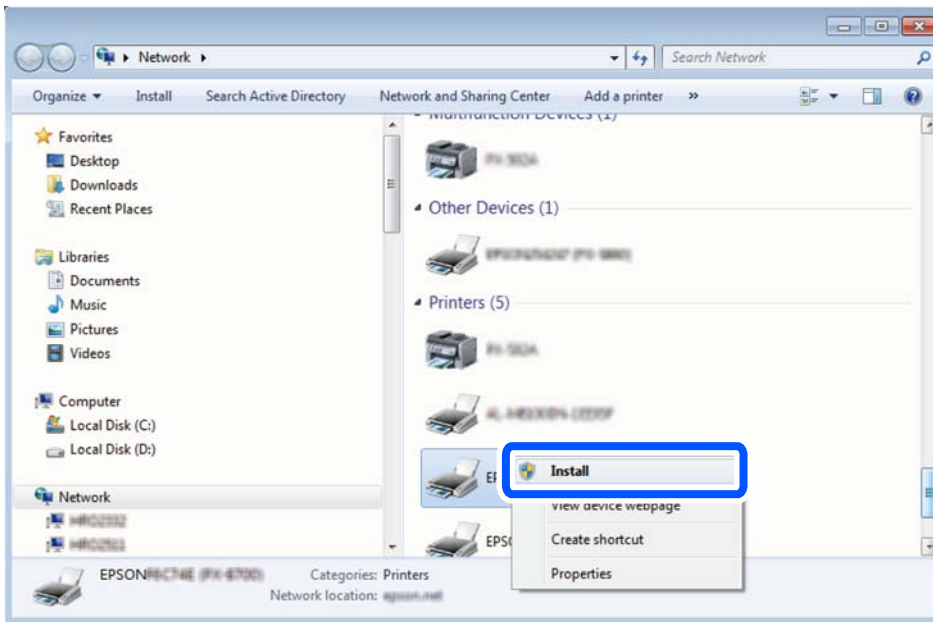

Note:

The printer name you set on the network and model name (EPSON XXXXXX (XX-XXXX)) are displayed on the network screen. You can check the printer's name set on the network from the printer's control panel or by printing a network status sheet.

4. Click **Your device is ready to use**.

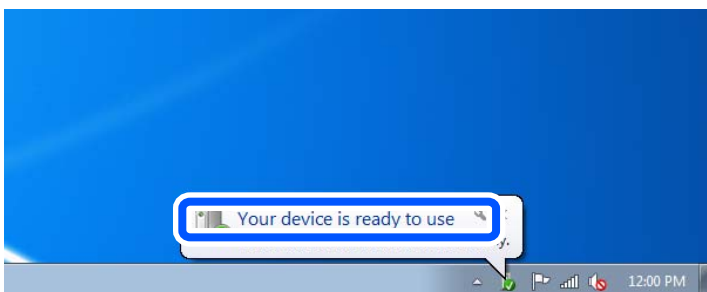

5. Check the message, and then click **Close**.

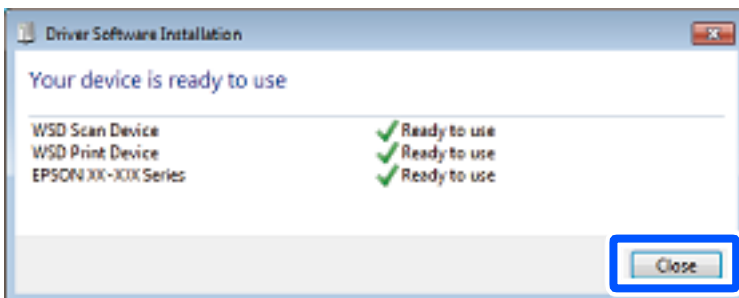

6. Open the **Devices and Printers** screen.
Click start > **Control Panel** > **Hardware and Sound** (or **Hardware**) > **Devices and Printers**.

7. Check that an icon with the printer's name on the network is displayed.
Select the printer name when using with WSD.

Scanning Originals to a Mobile Device

Note:

Before scanning, install Epson Smart Panel on your mobile device.

1. Place the originals.
“Placing Originals” on page 33
2. Start Epson Smart Panel on your mobile device.
3. Select scan menu on the home screen.
4. Follow the on-screen instructions to scan and save the images.

Scanning Using Mopria Scan

Mopria Scan enables scanning from Mopria certified multifunction printers and scanners from many manufacturers. Mobile scanning from your Android phone or tablet may be accomplished using the Mopria Scan app in the Google Play Store.



For more details, access the Mopria Web site at <https://mopria.org>.

Advanced Scanning

Scanning Multiple Photos at the Same Time

Using Epson ScanSmart, you can scan multiple photos at the same time and save each image individually.

Note:

Windows Server operating systems are not supported.

1. Place the photos on the scanner glass. Place them 4.5 mm (0.2 in.) away from the horizontal and vertical edges of the scanner glass, and place them at least 20 mm (0.8 in.) away from each other.

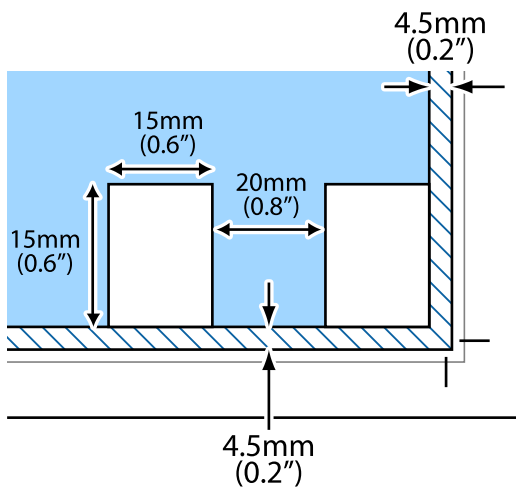

Note:

The photos should be larger than 15×15 mm (0.6×0.6 in.).

2. Start Epson ScanSmart.

- Windows 11

Click the start button, and then select **All apps > Epson Software > Epson ScanSmart**.

- Windows 10

Click the start button, and then select **Epson Software > Epson ScanSmart**.

- Windows 8.1/Windows 8

Enter the application name in the search charm, and then select the displayed icon.

- Windows 7

Click the start button, and then select **All Programs > Epson Software > Epson ScanSmart**.

- Mac OS

Select **Go > Applications > Epson Software > Epson ScanSmart**.

3. When the Epson ScanSmart screen is displayed, follow the on-screen instructions to scan.

Scanned photos are saved as individual images.

Maintaining the Printer

Checking the Ink Level.	75
Reset the Ink Level.	75
Improving Print, Copy, and Scan Quality.	76
Cleaning the Printer.	85
Cleaning Spilled ink.	85

Checking the Ink Level

To confirm the actual ink remaining, visually check the ink levels in all of the printer's tanks.

! *Important:*

Prolonged use of the printer when any ink level is below the lower line could damage the printer.

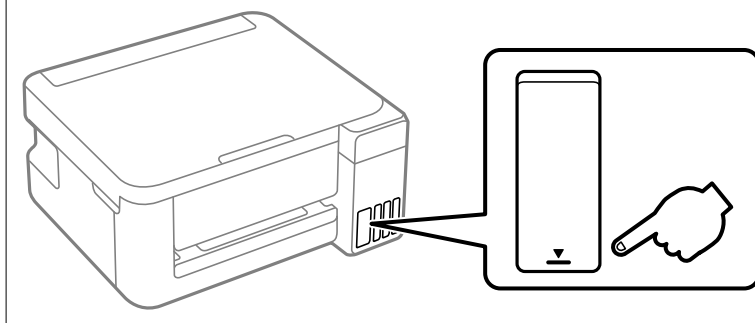

Note:

You can also check the approximate ink levels from the status monitor on the printer driver.

Windows

Click EPSON Status Monitor 3 on the Maintenance tab.

*If EPSON Status Monitor 3 is disabled, click Extended Settings on the Maintenance tab, and then select **Enable EPSON Status Monitor 3**.*

Mac OS

Apple menu > System Preferences > Printers & Scanners (or Print & Scan, Print & Fax) > Epson(XXXX) > Options & Supplies > Utility > Open Printer Utility > EPSON Status Monitor

Related Information

- ➔ [“It is Time to Refill the Ink” on page 150](#)
- ➔ [“It is Time to Replace the Maintenance Box” on page 156](#)

Reset the Ink Level

If the ink levels displayed by the printer's control panel does not match the actual ink levels in the ink tanks, reset the ink levels.

1. Select **More** on the printer's control panel.
2. Select **Maintenance > Set Ink Level**.
3. Adjust the ink levels as needed to match the ink levels in the ink tanks.

! *Caution:*

To confirm the actual ink remaining, visually check the ink levels in all of the printer's tanks.

4. Press the  button when you have finished adjusting the ink levels.

5. Press the OK button when a message is displayed indicating that setup is complete.

Improving Print, Copy, and Scan Quality

Adjusting the Print Quality

If you notice blank pages being ejected, misaligned vertical lines, blurred images, or horizontal banding, try **Print Quality Adjustment**.



Important:

Head cleaning may be necessary after performing **Print Quality Adjustment**. Check the following items when performing head cleaning.

- Head cleaning consumes ink and should not be performed more than necessary.
- When ink is low, you may not be able to clean the print head.
- Do not turn off the printer during head cleaning. If the head cleaning is incomplete, you may not be able to print.

1. Select **More** on the printer's control panel.
2. Select **Maintenance > Print Quality Adjustment**.
3. Follow the on-screen instructions to print the adjustment pattern and scan it.



Important:

Close the document cover before scanning.

Adjustments are performed automatically.

Note:

- When placing the adjustment pattern on the Scanner glass
Check the paper placed on the scanner glass and select **Start Scanning**. If the paper is folded or out of alignment with the corner mark, it cannot be scanned.
- Even if a blank sheet is ejected, follow the on-screen instructions to scan. If you scan a blank sheet of paper, scanning will fail. If this occurs, press the  button, and follow the on-screen instructions.
- If the problem does not improve even after performing **Print Quality Adjustment**, go to **Maintenance** to perform all available print head adjustments (nozzle check, cleaning, Alignment adjustment). See *Related Information* for more details.

Note:

You can also perform **Print Quality Adjustment** from the printer driver.

- Windows
Click **Maintenance** on the **Maintenance** tab, and then select **Print Quality Adjustment**.
- Mac OS
Apple menu > **System Preferences** (or **System Settings**) > **Printers & Scanners** (or **Print & Scan**, **Print & Fax**) > **Epson(XXXX)** > **Options & Supplies** > **Utility** > **Open Printer Utility** > **Print Quality Adjustment**

Related Information

- ➔ [“Checking and Cleaning the Print Head” on page 77](#)
- ➔ [“Aligning the Print Head” on page 81](#)

Checking and Cleaning the Print Head

If the nozzles are clogged, the printouts become faint, there is visible banding, or unexpected colors appear. If the nozzles are severely clogged, a blank sheet will be printed. When print quality has declined, first use the nozzle check feature to check if the nozzles are clogged. If the nozzles are clogged, clean the print head.



Important:

- Do not open the scanner unit or turn off the printer during head cleaning. If the head cleaning is incomplete, you may not be able to print.
- Head cleaning consumes ink and should not be performed more than necessary.
- When ink is low, you may not be able to clean the print head.
- If print quality has not improved after running a nozzle check and Cleaning alternately 3 times or Power Cleaning once, wait for at least 12 hours without printing (we recommend turning off the printer), and then run a nozzle check. If print quality has still not improved, run Cleaning and a nozzle check again. If it has still not improved, run Power Ink Flushing.
- To prevent the print head from drying out, do not unplug the printer while the power is on.

You can check and clean the print head by using the printer's control panel.

1. Select **More** on the printer's control panel.
To select an item, use the ◀▶ buttons, and then press the OK button.
2. Select **Maintenance > Nozzle Check**.
3. Follow the on-screen instructions to load paper and print the nozzle check pattern.
4. Check the printed pattern to see if the print head nozzles are clogged.

A) OK

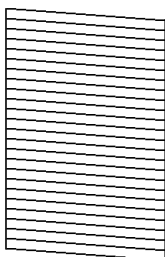

B) NG

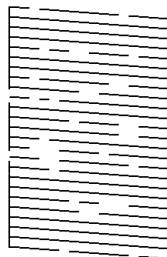

C) NG

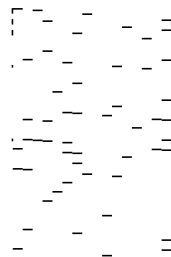

- A:
All lines are printed. Select **No**. No further steps are needed.

- B or close to B

Some nozzles are clogged. Select **Yes > Cleaning**, and then follow the on-screen instructions to clean the print head.

When cleaning is finished, another nozzle check pattern is printed automatically.

- C or close to C

If the printout comes out as a blank sheet or more than half of the lines is missing, most of the nozzles are clogged. Select **Yes > Power Cleaning**, and then follow the on-screen instructions. When cleaning is finished, another nozzle check pattern is printed automatically.

For details, see "Related information" below.

- Repeat cleaning and printing the pattern until all lines are printed completely.

 **Important:**

If all nozzle check lines are not printed completely after running a nozzle check and Cleaning alternately three times or Power Cleaning once, wait for at least 12 hours without printing (we recommend turning off the printer), and then run a nozzle check. If all nozzle check lines are not printed completely, run Cleaning and a nozzle check again. If all nozzle check lines are still not printed completely, run Power Ink Flushing.

Note:

You can also check and clean the print head from the printer driver.

- Windows

Click **Maintenance** on the **Maintenance** tab, and then select **Print Head Nozzle Check**.

- Mac OS

Apple menu > **System Preferences** (or **System Settings**) > **Printers & Scanners** (or **Print & Scan, Print & Fax**) > **Epson(XXXX)** > **Options & Supplies** > **Utility** > **Open Printer Utility** > **Print Head Nozzle Check**

Related Information

- ➔ ["Running Power Cleaning" on page 78](#)
- ➔ ["Running Power Ink Flushing" on page 79](#)

Running Power Cleaning

The **Power Cleaning** feature may improve print quality in the following cases.

- When most nozzles are clogged.
- When the printout comes out as a blank sheet.

Before running this feature, use the nozzle check feature to check if the nozzles are clogged, read the following instructions.

 **Important:**

The Power Cleaning uses more ink than the Cleaning.

- Select **More** on the printer's control panel.

To select an item, use the ◀▶ buttons, and then press the OK button.

2. Select **Maintenance > Head Cleaning**, and then select **Yes**, you can run the nozzle check. If you select **No**, you can select **Power Cleaning**.

3. Follow the on-screen instructions to run the Power Cleaning feature.

Note:

If you cannot run this feature, solve the problems that are displayed on the screen. Next, follow this procedure from step 1 to run this feature again.

4. When Power Cleaning is finished, a nozzle check is printed automatically so you can check whether any nozzles are still clogged.

 **Important:**

If all nozzle check lines are not printed completely after running Power Cleaning, wait for at least 12 hours without printing (we recommend turning off the printer), and then run a nozzle check. If all nozzle check lines are not printed completely, run Cleaning and a nozzle check again. If all nozzle check lines are not printed completely, run Power Ink Flushing.

Note:

You can also run **Power Cleaning** from the printer driver.

Windows

Maintenance tab > Maintenance > Print Head Cleaning > Power Cleaning

Mac OS

Apple menu > System Preferences (or System Settings) > Printers & Scanners (or Print & Scan, Print & Fax) > Epson(XXXX) > Options & Supplies > Utility > Open Printer Utility > Print Head Cleaning > Power Cleaning

Related Information

➔ [“Checking and Cleaning the Print Head” on page 77](#)

➔ [“Running Power Ink Flushing” on page 79](#)

Running Power Ink Flushing

The **Power Ink Flushing** utility allows you to replace all of the ink inside the ink tubes. In the following situations, you may need to use this feature to improve the print quality.

You printed or performed head cleaning when the ink levels were too low to be seen in the ink tank windows.

You performed the nozzle check and Cleaning three times or the Power Cleaning once, aited for at least 12 hours without printing, performed the Cleaning again, but all nozzle check lines are still not printed completely.

Before running this process, read the following instructions.

 **Important:**

Make sure that there is enough ink in the ink tanks.

Visually confirm that all ink tanks are at least a third full. Low ink levels during Power Ink Flushing could damage the product.

 **Important:**

Ink will be deposited in the maintenance box. If the maintenance box becomes full, you must prepare and install a replacement maintenance box to continue printing.

Note:

When the ink levels or the free space in the maintenance box are insufficient for Power Ink Flushing, you cannot run this process. Even in this case, there may be enough ink and free space in the maintenance box to continue printing.

1. Select **More** on the printer's control panel.

To select an item, use the ◀▶ buttons, and then press the OK button.

2. Select **Maintenance > Power Ink Flushing**.
3. Follow the on-screen instructions to run the Power Ink Flushing.

Note:

If you cannot run this utility, solve the problems that are displayed on the screen. Next, repeat the process from step 1.

4. After running the Power Ink Flushing, run the nozzle check to make sure the nozzles are not clogged.

For details on how to run the nozzle check, see the related information link below.

 **Important:**

If all nozzle check lines are still not printed completely after running Power Ink Flushing, contact Epson support.

Note:

*You can also run **Power Ink Flushing** from the printer driver.*

- Windows

*Click **Maintenance** on the **Maintenance** tab, and then select **Power Ink Flushing**.*

- Mac OS

*Apple menu > **System Preferences (or System Settings)** > **Printers & Scanners (or Print & Scan, Print & Fax)** > **Epson(XXXX)** > **Options & Supplies** > **Utility** > **Open Printer Utility** > **Power Ink Flushing***

Related Information

➔ [“Checking and Cleaning the Print Head” on page 77](#)

Preventing nozzle clogging

Always use the power button when turning the printer on and off.

Check that the power light is off before you disconnect the power cord.

The ink itself can dry out if it is not covered. Just like placing a cap on a fountain pen or an oil pen to prevent it from drying, make sure the print head is capped properly to prevent the ink from drying.

When the power cord is unplugged or a power outage occurs while the printer is in operation, the print head may not be capped properly. If the print head is left as it is, it will dry out causing nozzles (ink outlets) to clog.

In these cases, turn the printer on and off again as soon as possible to cap the print head.

Aligning the Print Head

If you notice a misalignment of vertical or horizontal lines, or blurred images, align the print head.

1. Select **More** on the printer's control panel.
To select an item, use the ◀▶ buttons, and then press the OK button.
2. Select **Maintenance > Print Head Alignment**.
3. Select one of the alignment menus.
 - If vertical lines look misaligned or the printouts look blurry, select **Vertical Alignment**.
 - If horizontal banding occurs at regular intervals, select **Horizontal Alignment**.
4. Follow the on-screen instructions.

Cleaning the Paper Path for Ink Smears

When the printouts are smeared or scuffed, clean the roller inside.



Important:

Do not use tissue paper to clean the inside of the printer. The print head nozzles may be clogged with lint.

1. Select **More** on the printer's control panel.
To select an item, use the ◀▶ buttons, and then press the OK button.
2. Select **Maintenance > Paper Guide Cleaning**.
3. Follow the on-screen instructions to load paper and clean the paper path.
4. Repeat this procedure until the paper is not smeared with ink.

Cleaning the Scanner Glass

When the copies or scanned images are smeared, clean the scanner glass.



Important:

Never use alcohol or thinner to clean the printer. These chemicals can damage the printer.

1. Open the document cover.

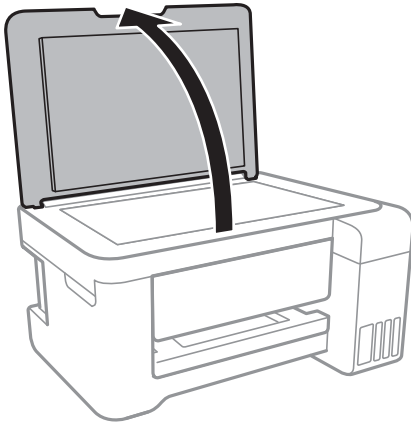

2. Use a soft, dry, clean cloth to clean the scanner glass.

! **Important:**

- If the glass surface is stained with grease or some other hard-to-remove material, use a small amount of glass cleaner and a soft cloth to remove it. Wipe off all remaining liquid.*
- Do not press the glass surface too hard.*
- Be careful not to scratch or damage the surface of the glass. A damaged glass surface can decrease the scan quality.*

Cleaning the Translucent Film

When the printout is not improved after aligning the print head or cleaning the paper path, the translucent film inside the printer may be smeared.

Items required:

- Cotton swabs (several)
- Water with a few drops of detergent (2 to 3 drops of detergent in 1/4 cup of tap water)
- Light for checking smears

! **Important:**

Do not use cleaning liquid other than water with a few drops of detergent.

1. Turn off the printer by pressing the  button.
2. Close the document cover if it is open.

3. Open the scanner unit with both hands until it locks.

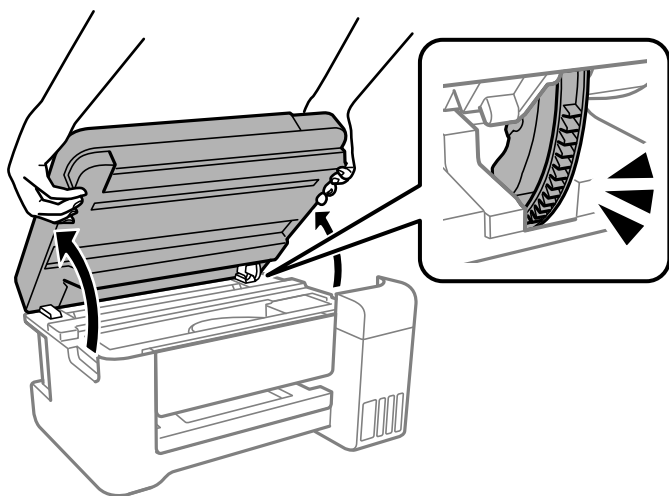

4. Check if the translucent film is smeared. Smears are easier to see if you use a light.
If there are smears (such as finger marks or grease) on the translucent film (A), go to the next step.

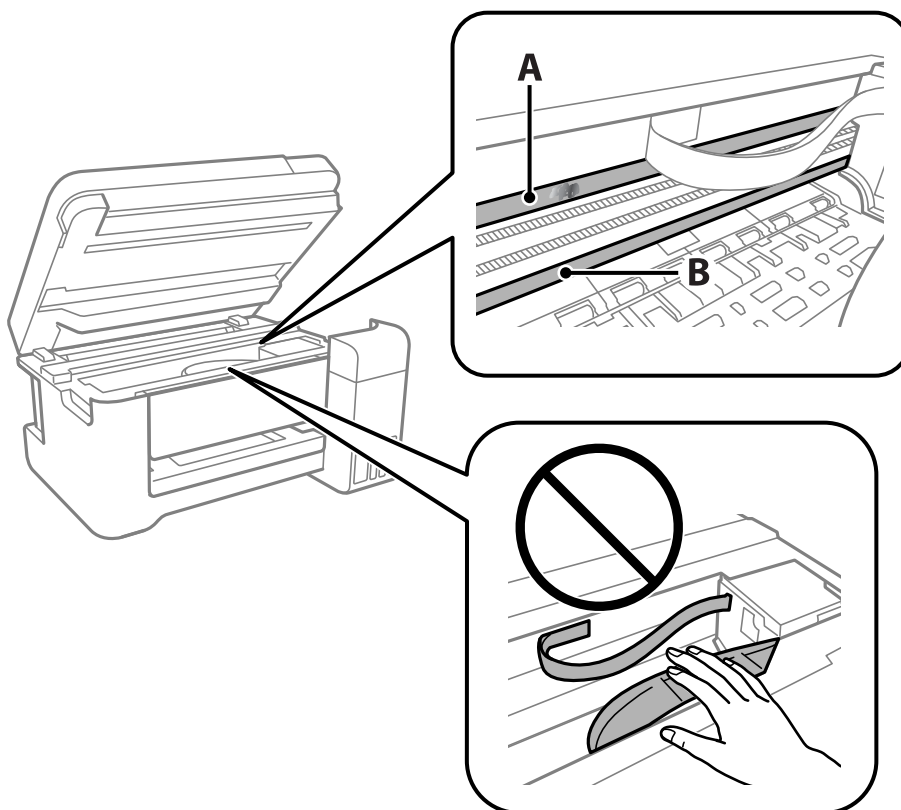

A: Translucent film

B: Rail



Important:

Be careful not to touch the rail (B). Otherwise, you may not be able to print. Do not wipe off the grease on the rail, because this is necessary for operations.

5. Moisten a cotton swab with the water with a few drops of detergent so that it is not dripping water, and then wipe the smeared part.

Be careful not to touch the ink that has adhered inside the printer.

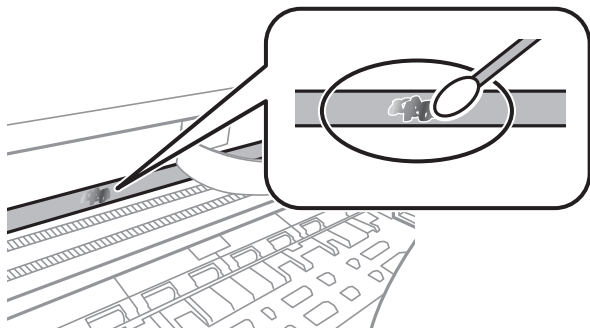

! **Important:**

Wipe off the smear gently. If you press the cotton swab too hard to the film, the springs of the film may be dislocated and the printer may be damaged.

6. Use a new dry cotton swab to wipe the film.

! **Important:**

Do not leave any fibers on the film.

Note:

To prevent the smear from spreading, frequently replace the cotton swab with a new one.

7. Repeat steps 5 and 6 until the film is not smeared.
8. Visually check that the film is not smeared.
9. Close the scanner unit.

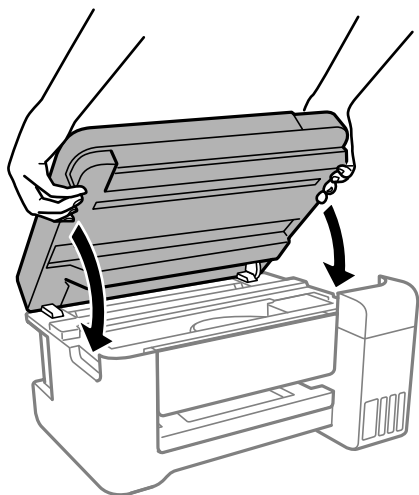

Note:

The scanner unit is designed to close slowly and resist a little as a precaution against catching fingers. Continue to close even if you feel some resistance.

Cleaning the Printer

If the components and the case are dirty or dusty, turn off the printer and clean them using a soft, clean cloth that has been dampened with water. If you cannot remove the dirt, try adding a small amount of mild detergent to the damp cloth.

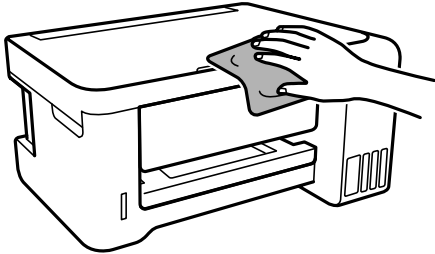

! *Important:*

- Be careful not to get water onto the printer mechanism or any electrical components. Otherwise, the printer could be damaged.*
- Never use alcohol or paint thinner to clean the components and the case. These chemicals can damage them.*
- Do not touch the parts shown in the following illustration. Doing so may cause a malfunction.*

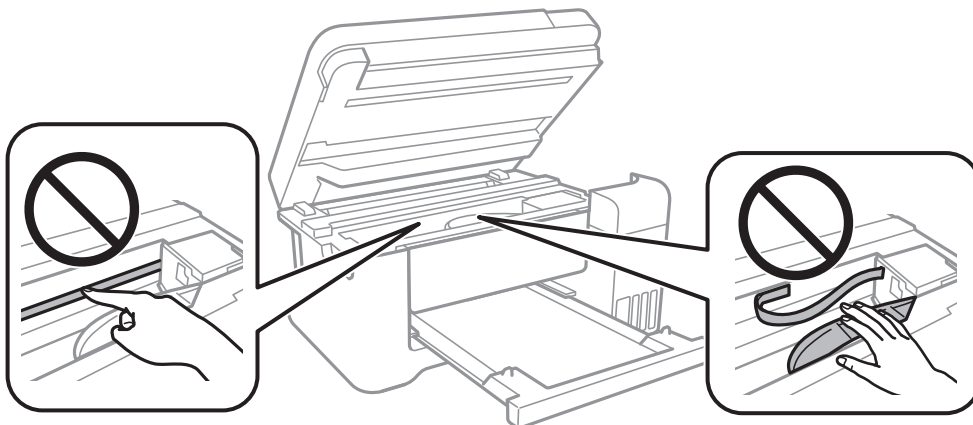

Cleaning Spilled ink

If ink has been spilled, follow these procedures to clean it up.

- If there is ink residue on the printer, in the area around the tank, wipe it off using a napless, clean cloth or cotton swab.
- If ink spills on the desk or floor, wipe it off immediately. If the ink dries, it will be difficult to remove. To prevent the spill from spreading, blot the ink with a dry cloth, and then wipe it with a moist cloth.
- If ink gets on your hands, wash them with water and soap.

In These Situations

When Replacing a Computer.	87
Saving Power.	87
Checking the Total Number of Pages Fed Through the Printer.	88
Installing the Applications Separately.	88
Resetting the Network Connection.	91
Connecting a Device and Printer Directly (Wi-Fi Direct).	103
Adding or Changing the Printer's Connection.	106
Transporting and Storing the Printer.	110

When Replacing a Computer

You need to install the printer driver and other software on the new computer.

U.S. and Canada

Access the following website and search for your product. Download and run your product's software package, then follow the instructions on the computer screen to run the setup program.

<https://support.epson.com>

Other Regions

Access the following website, and then enter the product name. Go to **Setup**, and then start setting up. Follow the on-screen instructions.

<https://epson.sn>

Saving Power

The printer enters sleep mode or turns off automatically if no operations are performed for a specified period. You can adjust the time before power management is applied. Any increase will affect the product's energy efficiency. Please consider the environment before making any change.

1. Select **More** on the home screen on the printer's control panel.

To select an item, use the ◀▶ buttons, and then press the OK button.

2. Select **Settings > Printer Setup**.

3. Do one of the following.

Select **Sleep Timer** or **Power Off Settings > Power Off If Inactive** or **Power Off If Disconnected**.

Select **Sleep Timer** or **Power Off Timer**.

Note:

*Your product may have the **Power Off Settings** or **Power Off Timer** feature depending on the location of purchase.*

4. Adjust settings as needed.

Disabling your Wi-Fi Connection

If you used to use Wi-Fi (wireless LAN) but no longer need to do so due to a change in connection mode and so on, you can disable your Wi-Fi connection.

By removing unnecessary Wi-Fi signals, you can also reduce the load on your standby power.

1. Select **Wi-Fi Setup** on the printer's home screen.

To select an item, use the ◀▶ buttons, and then press the OK button.

2. Select **Wi-Fi**.

3. Press the OK button.

4. Select **Others > Disable Wi-Fi**.

Follow the on-screen instructions.

Checking the Total Number of Pages Fed Through the Printer

You can check the total number of pages fed through the printer. The information is shown on the nozzle check pattern.

1. Select **More** on the printer's control panel.

To select an item, use the ◀▶ buttons, and then press the OK button.

2. Select **Maintenance > Nozzle Check**.

3. Follow the on-screen instructions to load paper and print the nozzle check pattern.

Note:

You can also use the printer driver to check the total number of pages fed.

- Windows

*Click **Printer and Option Information** on the **Maintenance** tab.*

- Mac OS

*Apple menu > **System Preferences** (or **System Settings**) > **Printers & Scanners** (or **Print & Scan**, **Print & Fax**) > **Epson(XXXX)** > **Options & Supplies** > **Utility** > **Open Printer Utility** > **Printer and Option Information***

Installing the Applications Separately

Connect your computer to the network and install the latest versions of applications from the website. Log in to your computer as an administrator. Enter the administrator password if the computer prompts you.

Note:

- When reinstalling an application, you need to uninstall it first.*

- You can download the latest applications from the Epson website.*

<https://www.epson.com>

- If you use Windows Server operating systems, you cannot use Epson Software Updater. Download the latest applications from the Epson website.*

1. Make sure the printer and the computer are available for communication, and the printer is connected to the Internet.

2. Start Epson Software Updater.

The screenshot is an example from Windows.

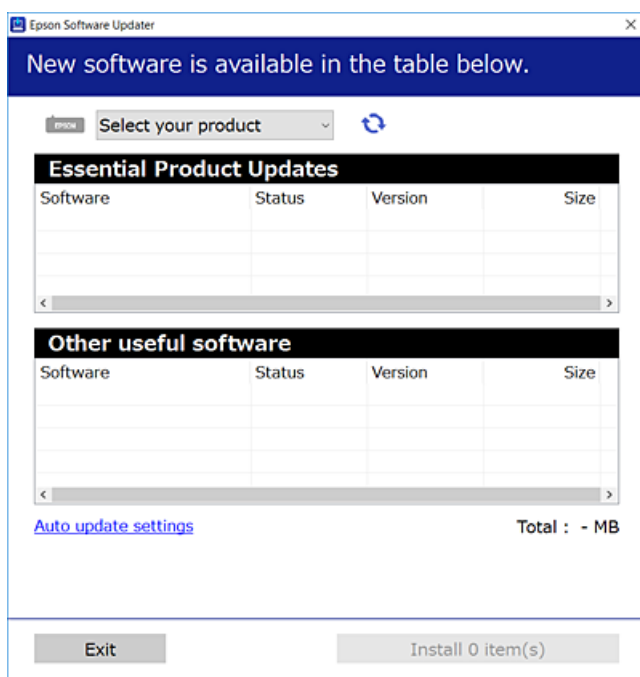

3. Select your printer, and then click  to check for the latest available applications.
4. Select the items you want to install or update, and then click the install button.



Important:

Do not turn off or unplug the printer until the update is complete. Doing so may result in malfunction of the printer.

Related Information

➔ [“Application for Updating Software and Firmware \(Epson Software Updater\)” on page 175](#)

Checking if a genuine Epson printer driver is installed - Windows

You can check if a genuine Epson printer driver is installed on your computer by using one of the following methods.

- Windows 11

Click on the start button, select **Settings > Bluetooth & devices > Printers & scanners**, and then click **Print server properties** under **Related settings**.

- ❑ Windows 10/Windows 8.1/Windows 8/Windows 7/Windows Server 2022/Windows Server 2019/Windows Server 2016/Windows Server 2012 R2/Windows Server 2012/Windows Server 2008 R2

Select **Control Panel > View devices and printers (Printers, Printers and Faxes)** in **Hardware and Sound**, click the printer icon, and then click **Print server properties** at the top of the window.

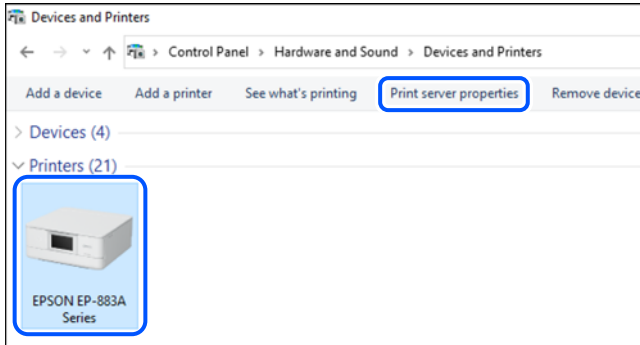

- ❑ Windows Server 2008

Right-click on the **Printers** folder, and then click **Run as administrator > Server Properties**.

Click the **Drivers** tab. If your printer name is displayed in the list, a genuine Epson printer driver is installed on your computer.

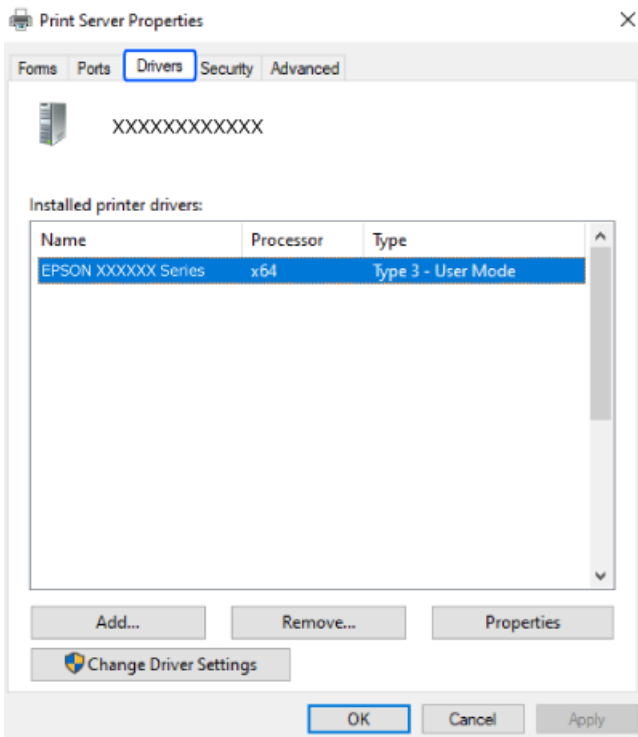

Related Information

- ➔ [“Installing the Applications Separately” on page 88](#)

Checking if a genuine Epson printer driver is installed - Mac OS

You can check if a genuine Epson printer driver is installed on your computer by using one of the following methods.

Select **System Preferences** (or **System Settings**) from the Apple menu > **Printers & Scanners** (or **Print & Scan**, **Print & Fax**), and then select the printer. Click **Options & Supplies**, and if the **Options** tab and **Utility** tab are displayed on the window, a genuine Epson printer driver is installed on your computer.

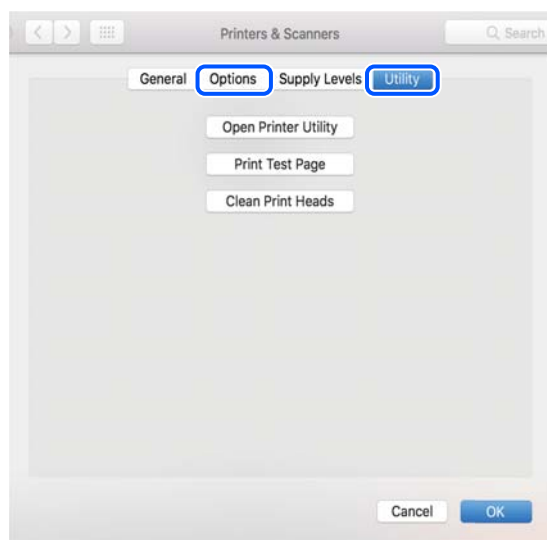

Related Information

➔ [“Installing the Applications Separately” on page 88](#)

Resetting the Network Connection

The printer's network settings need to be adjusted in the following cases.

- When using a printer with a network connection
- Your network environment has changed
- You replaced the wireless router
- You changed the way the printer connects to the computer (for example, switching from a USB connection to a Wi-Fi connection)

Adjusting Settings When Connecting to a Computer

You can run the installer using one of the following methods.

Setting up from the website

U.S., Canada, and Latin America

Access the following website and search for your product. Download and run your product's software package, then follow the instructions on the computer screen to run the setup program.

<https://support.epson.com>

Other Regions

Access the following website, and then enter the product name. Go to **Setup**, and then start setting up.

<https://epson.sn>

 You can also watch the procedure in the Web Video Manuals. Access the following website.

<https://support.epson.net/publist/vlink.php?code=NPD7415>

For users in China, access the following website.

<https://support.epson.net/publist/vlink.php?code=NPD7416>

Setting up using the software disc

If your printer came with a software disc and you are using a Windows computer with a disc drive, insert the disc into the computer, and then follow the on-screen instructions.

Adjusting Settings When Connecting to a Mobile Device

You can use the printer from your mobile device when they are connected to the same wireless network.

U.S., Canada, and Latin America

Make sure you have the following.

- A mobile device that is connected to the wireless network, has Bluetooth enabled, and has the Epson Smart Panel app installed (Epson Smart Panel is available for iOS and Android devices.)
- The wireless network name (SSID) and password

Note:

Your mobile device must be close enough to the printer to create and maintain a Bluetooth connection.

Make sure the product is turned on and ready to print.

Note:

You must perform initial setup and ink installation before setting up wireless printing

Open the Epson Smart Panel app.

Do one of the following:

- If the app automatically recognizes the product, follow the on-screen instructions to set up the wireless connection.
- If the app does not automatically recognize the product, select the + icon, select the option to set up a new product, and follow the on-screen instructions.

Other Regions

To set up a new connection, access the following website from the mobile device that you want to connect to the printer. Enter the product name, go to Setup, and then start the setup.

<https://epson.sn>

 You can watch the procedure in the Web Video Manuals. Access the following website.

<https://support.epson.net/publist/vlink.php?code=VC00006>

For users in China, access the following website.

<https://support.epson.net/publist/vlink.php?code=NPD7083>

Note:

If you have already set up the connection between your mobile device and the printer but need to reconfigure it, you can do so from an app such as Epson Smart Panel.

Configuring Wi-Fi Settings from the Control Panel

If you are not using a computer or mobile device to set up the printer connection, you can do so on the control panel.

You can select network settings from the printer's control panel in several ways. Choose the connection method that matches the environment and conditions that you are using.

If you know the SSID and password for your wireless router, you can set them manually.

Related Information

- ➔ [“Making Wi-Fi Settings by Entering the SSID and Password” on page 93](#)
- ➔ [“Making Wi-Fi Settings by Push Button Setup \(WPS\)” on page 94](#)
- ➔ [“Making Wi-Fi Settings by PIN Code Setup \(WPS\)” on page 95](#)

Making Wi-Fi Settings by Entering the SSID and Password

You can set up a Wi-Fi network by entering the information necessary to connect to a wireless router from the printer's control panel. To set up using this method, you need the SSID and password for a wireless router.

Note:

If you are using an wireless router with its default settings, the SSID and password are on the label. If you do not know the SSID and password, contact the person who set up the wireless router, or see the documentation provided with the wireless router.

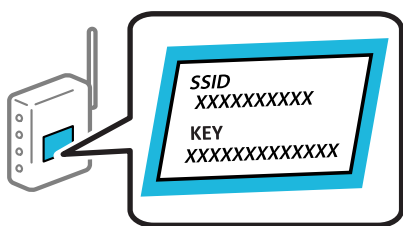

1. Select **Wi-Fi Setup** on the home screen.
To select an item, use the ◀▶ buttons, and then press the OK button.
2. Select **Wi-Fi**.
3. Press the OK button to proceed.
4. Select **Wi-Fi Setup Wizard**.

5. Select the SSID for the wireless router from printer's control panel, and then press the OK button.

Note:

- If the SSID you want to connect to is not displayed on the printer's control panel, press the  button to update the list. If it is still not displayed, select **Other SSIDs**, and then enter the SSID directly.
- If you do not know the SSID, check if it is written on the label of the wireless router. If you are using the wireless router with its default settings, use the SSID written on the label.
- If the SSID you want to connect to is not displayed, make Wi-Fi settings using software or apps on your computer or mobile device. For more information, enter <https://epson.sn> in your browser to open the website, enter your product name, and go to **Setup**.

6. Enter the password.

Select whether or not you print a network connection report after finishing the settings.

Note:

- The password is case-sensitive.
- If you do not know the network name (SSID) check if the information is written on the label of the wireless router. If you are using the wireless router with its default settings, use the SSID on the label. If you cannot find any information, see the documentation provided with the wireless router.

7. When you have setup finished, and then press the OK button.

Note:

If you fail to connect, load paper, and then press the  button to print a network connection report.

Related Information

- ➔ [“Checking the Printer's Network Connection Status \(Network Connection Report\)” on page 96](#)

Making Wi-Fi Settings by Push Button Setup (WPS)

You can automatically set up a Wi-Fi network by pressing a button on the wireless router. If the following conditions are met, you can set up by using this method.

- The wireless router is compatible with WPS (Wi-Fi Protected Setup).
- The current Wi-Fi connection was established by pressing a button on the wireless router.

1. Select **Wi-Fi Setup** on the home screen.

To select an item, use the   buttons, and then press the OK button.

2. Select **Wi-Fi**.

3. Press the OK button to proceed.

4. Select **Push Button Setup (WPS)**.

5. Hold down the [WPS] button on the wireless router until the security light flashes.

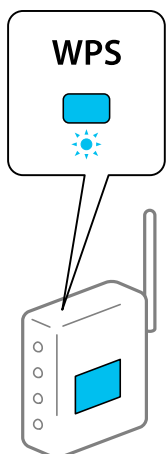

If you do not know where the [WPS] button is, or there are no buttons on the wireless router, see the documentation provided with your wireless router for details.

6. Press the OK button on the printer's control panel. Follow the on-screen instruction hereafter.

Note:

If connection fails, restart the wireless router, move it closer to the printer, and try again. If it still does not work, print a network connection report and check the solution.

Related Information

➔ [“Checking the Printer's Network Connection Status \(Network Connection Report\)” on page 96](#)

Making Wi-Fi Settings by PIN Code Setup (WPS)

You can automatically connect to an wireless router by using a PIN code. You can use this method to set up if an wireless router is capable of WPS (Wi-Fi Protected Setup). Use a computer to enter a PIN code into the wireless router.

1. Select **Wi-Fi Setup** on the home screen.
To select an item, use the ◀▶ buttons, and then press the OK button.
2. Select **Wi-Fi**.
3. Press the OK button to proceed.
4. Select **Others**.
5. Select **PIN Code (WPS)**.
6. Use your computer to enter the PIN code (an eight digit number) displayed on the printer's control panel into the wireless router within two minutes.

Note:

See the documentation provided with your wireless router for details on entering a PIN code.

7. Press the OK button on the printer.

Setup is complete when the setup completion message is displayed.

Note:

If connection fails, restart the wireless router, move it closer to the printer, and try again. If it still does not work, print a connection report and check the solution.

Related Information

- ➔ [“Checking the Printer's Network Connection Status \(Network Connection Report\)” on page 96](#)

Checking the Printer's Network Connection Status (Network Connection Report)

You can print a report to check the status of the network connection between the printer and the router.

1. Load paper in the printer.

[“Loading Paper in the Rear Paper Feeder” on page 27](#)

2. Select **More** on the home screen on the printer's control panel.

To select an item, use the ◀▶ buttons, and then press the OK button.

3. Select **Settings**.

To select an item, use the ▲▼ buttons, and then press the OK button.

4. Select **Network Settings > Connection Check**.

The connection check starts.

5. Follow the instructions on the printer's screen to print the network connection report.

If an error has occurred, check the network connection report and review the possible causes and solutions.

Messages and Solutions on the Network Connection Report

Check the messages and error codes on the Network Connection Report, and then follow the solutions.

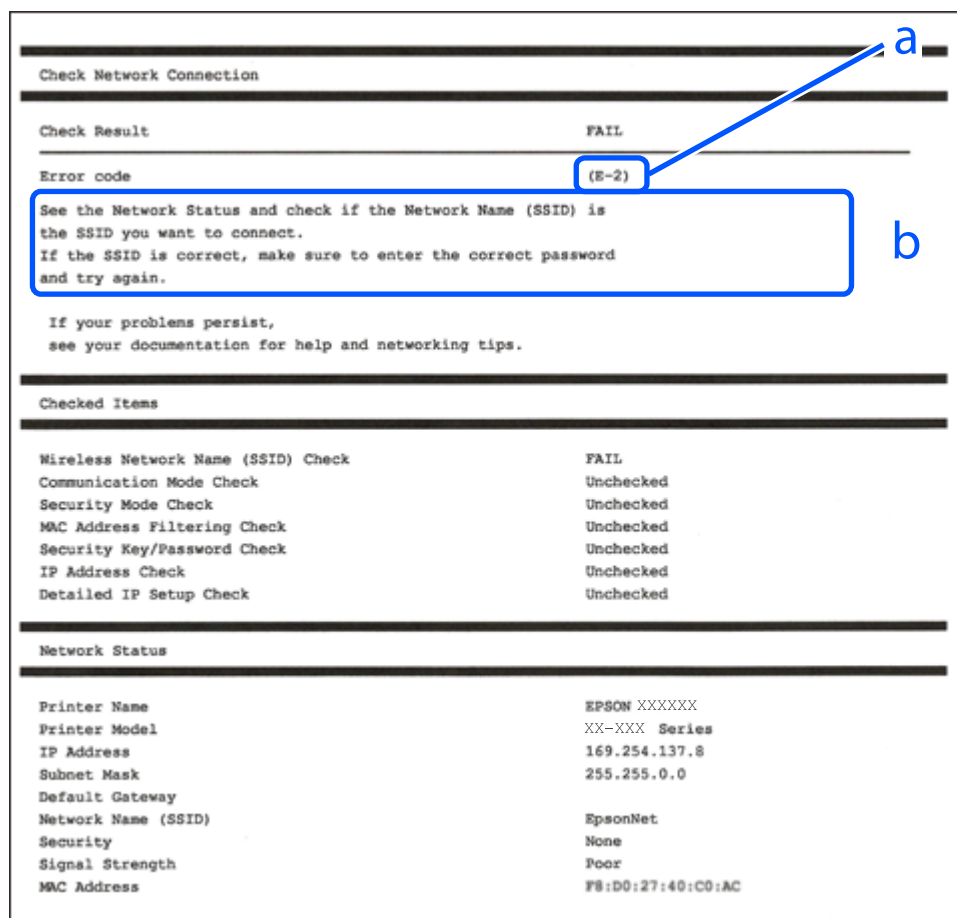

a. Error code

b. Network Environment Message

Related Information

- ➔ “E-1” on page 98
- ➔ “E-2, E-3, E-7” on page 98
- ➔ “E-5” on page 99
- ➔ “E-6” on page 99
- ➔ “E-8” on page 99
- ➔ “E-9” on page 100
- ➔ “E-10” on page 100
- ➔ “E-11” on page 101
- ➔ “E-12” on page 101
- ➔ “E-13” on page 102
- ➔ “Network Environment Messages” on page 102

E-1

Solutions:

- Make sure your hub or other network device is turned on.
- If you want to set up a Wi-Fi connection, reselect the Wi-Fi settings because they are currently disabled.

Related Information

➔ [“Configuring Wi-Fi Settings from the Control Panel” on page 93](#)

E-2, E-3, E-7

Solutions:

- Make sure your wireless router is turned on.
- Confirm that your computer or device is connected correctly to the wireless router.
- Turn off the wireless router. Wait for about 10 seconds, and then turn it on.
- Place the printer closer to your wireless router and remove any obstacles between them.
- If you have entered the SSID manually, check if it is correct. Check the SSID from the **Network Status** section of the network connection report.
- If a wireless router has multiple SSIDs, select the SSID that is displayed. If the SSID is using a non-compliant frequency, the printer will not display it.
- If you are using push button setup to establish a network connection, make sure your wireless router supports WPS. You cannot use push button setup if your wireless router does not support WPS.
- Make sure you know your SSID and password before connecting to the wireless router. If you are using a wireless router with its default settings, the SSID and password are located on a label on the wireless router. If you do not know your SSID and password, contact the person who set up the wireless router, or see the documentation provided with the wireless router.
- If you are connecting to an SSID generated from a tethering mobile device, check for the SSID and password in the documentation provided with the mobile device.
- If your Wi-Fi connection suddenly disconnects, check for the conditions below. If any of these conditions are applicable, reset your network settings by downloading and running the software from the following website.
<https://support.epson.com> (U.S. and Canada)
<https://epson.sn> > **Setup** (Other regions)
 - A mobile device was added to the network using push button setup.
 - The printer was connected to the network using any method other than push button setup.
 - The wireless router was replaced.

Related Information

➔ [“Resetting the Network Connection” on page 91](#)
➔ [“Configuring Wi-Fi Settings from the Control Panel” on page 93](#)

E-5

Solutions:

- Make sure the wireless router's security type is set to one of the options below. If it is set to anything else, change the security type on the wireless router.
 - WEP-64 bit (40 bit)
 - WEP-128 bit (104 bit)
 - WPA PSK (TKIP/AES)*
 - WPA2 PSK (TKIP/AES)*
 - WPA3-SAE (AES)

* WPA PSK is also known as WPA Personal. WPA2 PSK is also known as WPA2 Personal.

- Turn off the wireless router. Wait for about 10 seconds, and then turn it on.
- Reconfigure the printer's network settings.

E-6

Solutions:

- If MAC address filtering is enabled, register the printer's MAC address so that it is not filtered. See the documentation provided with the wireless router for details. You can check the printer's MAC address from the **Network Status** section of the Network Connection Report.
- If your wireless router is using shared authentication with WEP security, make sure the authentication key and index are correct.
- If the number of connections allowed on the wireless router is less than the number of devices that you want to connect, reconfigure settings on the wireless router to increase the number of connections allowed. See the documentation provided with the wireless router for details.
- Turn off the wireless router. Wait for about 10 seconds, and then turn it on.
- Reconfigure the printer's network settings.

Related Information

➔ [“Adjusting Settings When Connecting to a Computer” on page 91](#)

E-8

Solutions:

- If the wireless router's DHCP is enabled, set the printer's TCP/IP settings to Auto.
- If the printer's Obtain IP Address setting is set to Manual, the IP address you manually set is invalid because it is out of range (for example: 0.0.0.0). Enter a valid IP address from the printer's control panel.
- Turn off the wireless router. Wait for about 10 seconds, and then turn it on.
- Reconfigure the printer's network settings.

Related Information

➔ “Setting a Static IP Address for the Printer” on page 108

E-9

Solutions:

Confirm the following:

- The devices are turned on.
- You can access the Internet and other computers or network devices on the same network from the devices you want to connect to the printer.

If your printer and network devices still do not connect after confirming the above, try the following.

- Turn off the wireless router. Wait for about 10 seconds, and then turn it on.
- Configure network settings from a computer on the same network as the printer by downloading and running the software from the following website.

<https://support.epson.com> (U.S. and Canada)

<https://epson.sn> > **Setup** (Other regions)

If the problem continues to occur, check the IP address of the printer listed in the Network Connection Report and contact your router manufacturer.

Related Information

➔ “Adjusting Settings When Connecting to a Computer” on page 91

E-10

Solutions:

Confirm the following:

- Other devices on the network are turned on.
- The network addresses (IP address, subnet mask, and default gateway) are correct if you have set the printer's Obtain IP Address setting set to Manual.

Reset the network addresses if they are incorrect. You can check the IP address, subnet mask, and default gateway from the **Network Status** section on the network connection report.

If DHCP is enabled, change the printer's Obtain IP Address setting to Auto. If you want to set the IP address manually, check the printer's IP address from the **Network Status** section of the network connection report, and then select Manual on the network settings screen. Set the subnet mask to [255.255.255.0].

If your printer and network devices still do not connect after confirming the above, try the following.

- Turn off the wireless router. Wait for about 10 seconds, and then turn it on.
- Configure network settings from a computer on the same network as the printer by downloading and running the software from the following website.

<https://support.epson.com> (U.S. and Canada)

<https://epson.sn> > **Setup** (Other regions)

Related Information

➔ [“Setting a Static IP Address for the Printer” on page 108](#)

E-11

Solutions:

Confirm the following:

- The default gateway address is correct if you set the printer's TCP/IP Setup setting to Manual.
- The device that is set as the default gateway is turned on.

Set the correct default gateway address. You can check the default gateway address from the **Network Status** section on the network connection report.

If your printer and network devices still do not connect after confirming the above, try the following.

- Turn off the wireless router. Wait for about 10 seconds, and then turn it on.
- Configure network settings from a computer on the same network as the printer by downloading and running the software from the following website.

<https://support.epson.com> (U.S. and Canada)

<https://epson.sn> > **Setup** (Other regions)

Related Information

➔ [“Setting a Static IP Address for the Printer” on page 108](#)

E-12

Solutions:

Confirm the following:

- Other devices on the network are turned on.
- The network addresses (IP address, subnet mask, and default gateway) are correct if you are entering them manually.
- The network addresses for other devices (subnet mask and default gateway) are the same.
- The IP address does not conflict with other devices.

If your printer and network devices still do not connect after confirming the above, try the following.

- Turn off the wireless router. Wait for about 10 seconds, and then turn it on.
- Configure network settings again using the installer. You can run it from the following website.

<https://support.epson.com> (U.S. and Canada)

<https://epson.sn> > **Setup** (Other regions)

- You can register several passwords on a wireless router that uses the WEP security type. If several passwords are registered, check if the first registered password is entered in the printer.

Related Information

➔ “Setting a Static IP Address for the Printer” on page 108

E-13

Solutions:

Confirm the following:

- Network devices such as a wireless router, hub, and router are turned on.
- The TCP/IP Setup for network devices has not been done manually. (If the printer’s TCP/IP Setup is done automatically while the TCP/IP Setup for other network devices is done manually, the printer’s network may differ from the network for other devices.)

If it still does not work after checking the above, try the following.

- Turn off the wireless router. Wait for about 10 seconds, and then turn it on.
- Configure network settings from a computer on the same network as the printer by downloading and running the software from the following website.
 - <https://support.epson.com> (U.S. and Canada)
 - <https://epson.sn> > **Setup** (Other regions)
- You can register several passwords on a wireless router that uses the WEP security type. If several passwords are registered, check if the first registered password is entered in the printer.

Related Information

- ➔ “Adjusting Settings When Connecting to a Computer” on page 91
- ➔ “Setting a Static IP Address for the Printer” on page 108

Network Environment Messages

Message	Solution
The Wi-Fi environment needs to be improved. Turn the wireless router off and then turn it on. If the connection does not improve, see the documentation for the wireless router.	After moving the printer closer to the wireless router and removing any obstacles between them, turn off the wireless router. Wait for about 10 seconds, and then turn it on. If it still does not connect, see the documentation supplied with the wireless router.
*No more devices can be connected. Disconnect one of the connected devices if you want to add another one.	You have connected the maximum number of devices allowed via the printer’s Wi-Fi Direct (Simple AP) connection. To add another computer or mobile device, disconnect one of the connected devices. You can confirm the number of devices that can be connected simultaneously and the number of connected devices by checking the network status sheet or the printer’s control panel.
The same SSID as Wi-Fi Direct exists in the environment. Change the Wi-Fi Direct SSID if you cannot connect a mobile device to the printer.	On the printer’s control panel, go to the Wi-Fi Direct Setup screen and select the menu to change the setting. You can change the part of the network name that after DIRECT-XX-. The network name must be 22 characters or less.

Connecting a Device and Printer Directly (Wi-Fi Direct)

Wi-Fi Direct (Simple AP) allows you to connect a device directly to the printer without a wireless router and print from the device.

About Wi-Fi Direct

Use this connection method when you are not using Wi-Fi at home or at the office, or when you want to connect the printer and the computer or mobile devices directly. In this mode, the printer acts as a wireless router and you can connect the devices to the printer without having to use a standard wireless router. However, devices directly connected to the printer cannot communicate with each other through the printer.

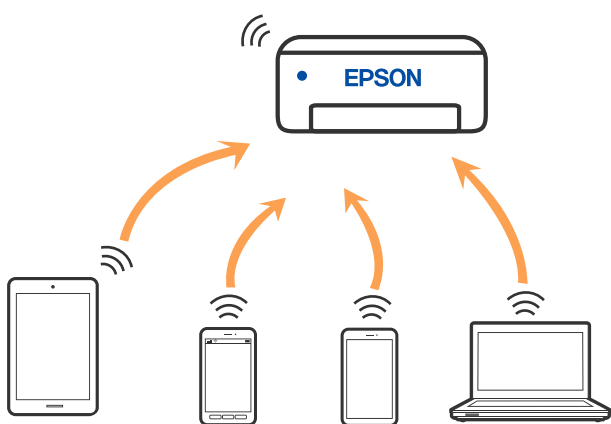

The printer can be connected via a Wi-Fi Direct (Simple AP) connection and a Wi-Fi(Infrastructure) connection simultaneously.

Connecting to Devices using Wi-Fi Direct

This method allows you to connect the printer directly to mobile devices without a wireless router.

Note:

For iOS or Android users, it is convenient to set up from Epson Smart Panel.

You only need to make these settings for the printer and the mobile device that you want to connect to once. Unless you disable Wi-Fi Direct or restore the network settings to their defaults, you do not need to make these settings again.

1. Select **Wi-Fi Setup** on the home screen.
To select an item, use the ◀▶ buttons, and then press the OK button.
2. Select **Wi-Fi Direct**.
3. Check the message, and then press the OK button to proceed.
4. Check the message, and then press the OK button to proceed.
5. Press the ◀.
6. Select **Other OS Devices**.

7. Scroll the screen with the ▼ button, and check the connection information for Wi-Fi Direct.
8. On the mobile device's Wi-Fi screen, select the SSID shown on the printer's control panel, and then enter the password.

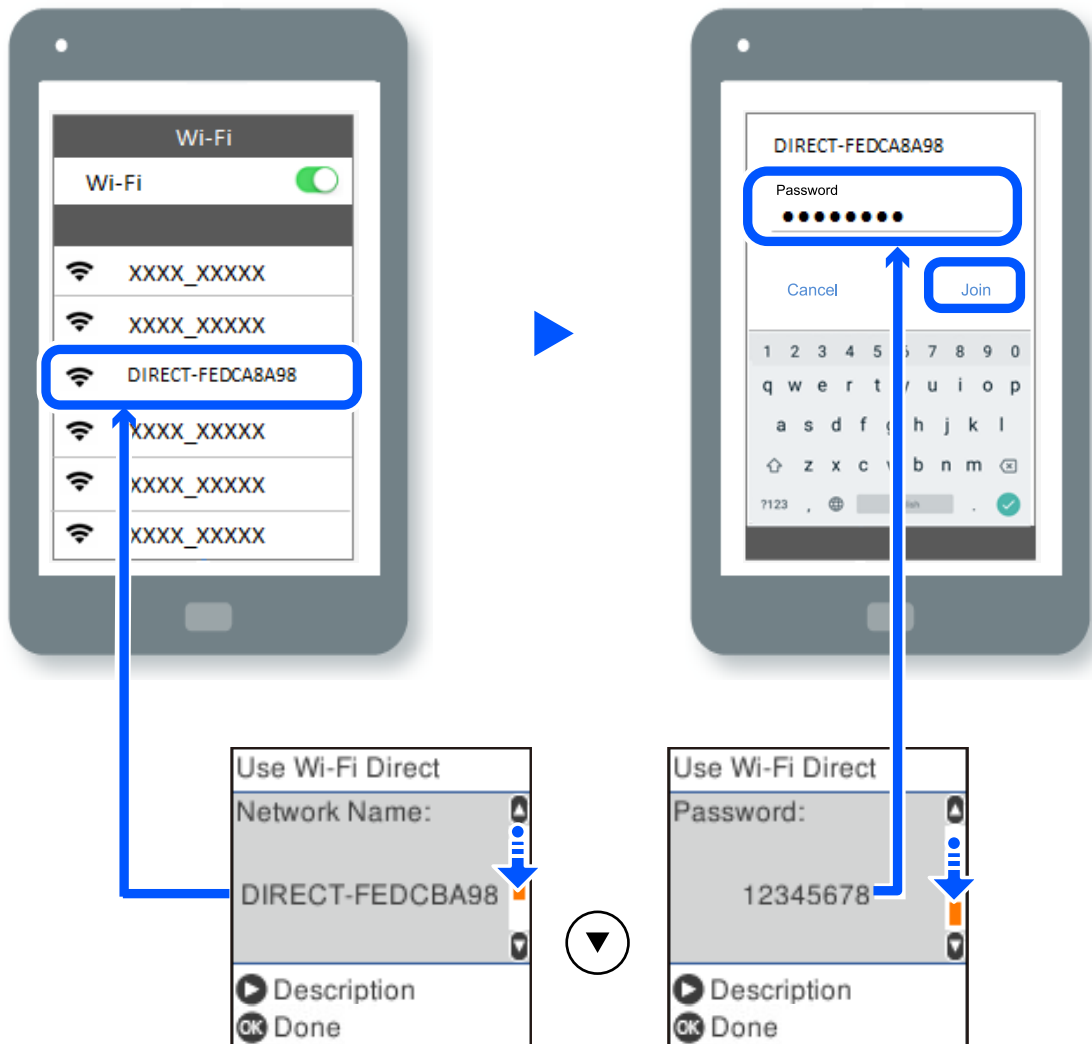

9. On the printer's control panel, press the OK button.
 10. On the printing app screen for the mobile device, select the printer that you want to connect to.
- For mobile devices that have been connected to the printer before, select the network name (SSID) on the mobile device's Wi-Fi screen to connect them again.

Note:

If you are using an iOS device, you can also connect by scanning the QR code with the standard iOS camera. See the link below <https://epson.sn>.

Disconnecting Wi-Fi Direct (Simple AP) Connection

There are two methods available to disable a Wi-Fi Direct (Simple AP) connection; you can disable all connections by using the printer's control panel, or disable each connection from the computer or the mobile device. This section explains how to disable all connections.

 **Important:**

When Wi-Fi Direct (Simple AP) connection disabled, all computers and mobile devices connected to the printer in Wi-Fi Direct (Simple AP) connection are disconnected.

Note:

If you want to disconnect a specific device, disconnect from the device instead of the printer. Use one of the following methods to disconnect the Wi-Fi Direct (Simple AP) connection from the device.

- Disconnect the Wi-Fi connection to the printer's network name (SSID).
- Connect to another network name (SSID).

1. Select **Wi-Fi Setup** on the home screen.

To select an item, use the ◀▶ buttons, and then press the OK button.

2. Select **Wi-Fi Direct**.
3. Press the OK button to proceed.
4. Press the OK button to proceed.
5. Press the ↺ button to display the setting screen.
6. Select **Disable Wi-Fi Direct**.
7. Check the message, and then press the OK button.

Changing the Wi-Fi Direct (Simple AP) Settings Such as the SSID

When a Wi-Fi Direct (Simple AP) connection is enabled, you can change the Wi-Fi Direct settings such as the network name and the password.

1. Select **Wi-Fi Setup** on the home screen.

To select an item, use the ◀▶ buttons, and then press the OK button.

2. Select **Wi-Fi Direct**.
3. Press the OK button to proceed.
4. Press the OK button to proceed.
5. Press the ↺ button to display the setting screen.
6. Select the menu item that you want to change.

You can select the following menu items.

Change Network Name

Change the Wi-Fi Direct (simple AP) network name (SSID) used for connecting to the printer to your arbitrary name. You can set the network name (SSID) in ASCII characters that is displayed on the software keyboard on the control panel.

When changing the network name (SSID), all connected devices are disconnected. Use the new network name (SSID) if you want to re-connect the device.

Change Password

Change the Wi-Fi Direct (simple AP) password for connecting to the printer to your arbitrary value. You can set the password in ASCII characters that is displayed on the software keyboard on the control panel.

When changing the password, all connected devices are disconnected. Use the new password if you want to re-connect the device.

Change Frequency Range

Change the frequency range of Wi-Fi Direct used for connecting to the printer. You can select 2.4 GHz or 5 GHz.

When changing the frequency range, all connected devices are disconnected. Re-connect the device.

Note that you cannot re-connect from devices that do not support 5 GHz frequency range when changing to 5 GHz.

Disable Wi-Fi Direct

Disable Wi-Fi Direct (simple AP) settings of the printer. When disabling it, all devices connected to the printer in Wi-Fi Direct (Simple AP) connection are disconnected.

Restore Default Settings

Restore all Wi-Fi Direct (simple AP) settings to their defaults.

The Wi-Fi Direct (simple AP) connection information of the mobile device saved to the printer is deleted.

7. Follow the on-screen instruction.

Adding or Changing the Printer's Connection

To Set Up a Printer on Multiple Computers

Although several computers can be connected to the same wireless router, each computer may be assigned a different SSID.

If the SSIDs assigned by the wireless router are not handled as the same network, then each computer is effectively connected to a different network. When you start setting up the printer from computer A, the printer is added to the same network as computer A allowing computer A to print from it.

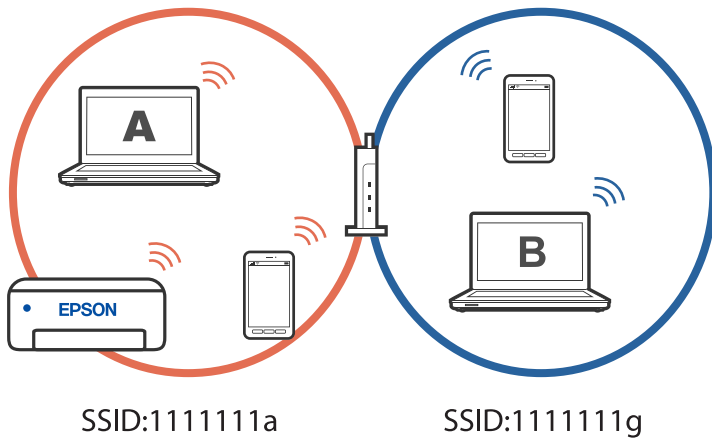

Furthermore, if you start setting up the printer from computer B in the configuration shown above, the printer is set up on computer B's network allowing computer B to print but not computer A.

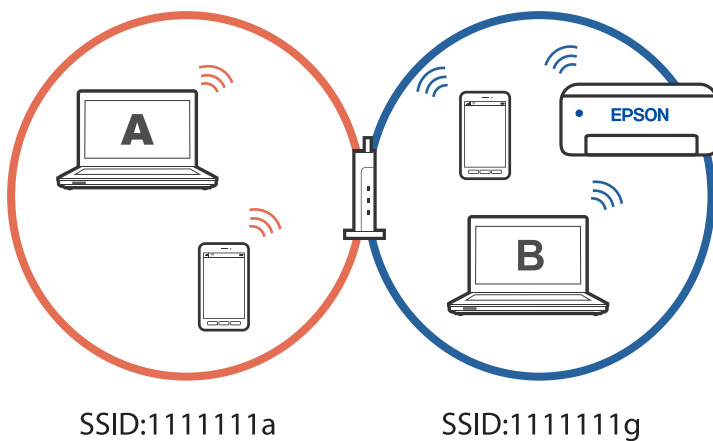

To prevent this from happening, when you want to connect the printer to a second computer, make sure the second computer is on the same network as the printer before you begin setup.

Changing the Connection from Wi-Fi to USB

Follow the steps below if the Wi-Fi you are using is unstable, or if you want to change to a more stable USB connection.

1. Connect the printer to a computer using a USB cable.

2. When you print, select the printer whose name does not end with "(Network)" or the printer name in parentheses.

Example of Windows 11

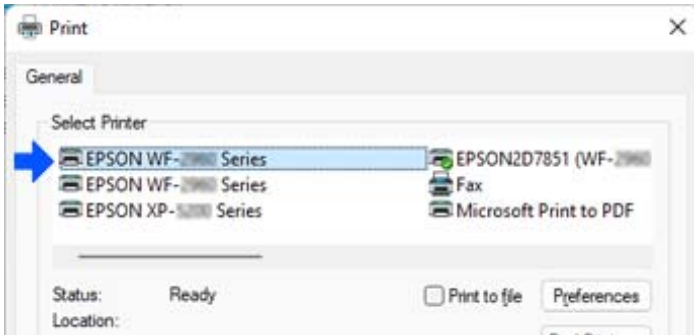

Example of Windows 10

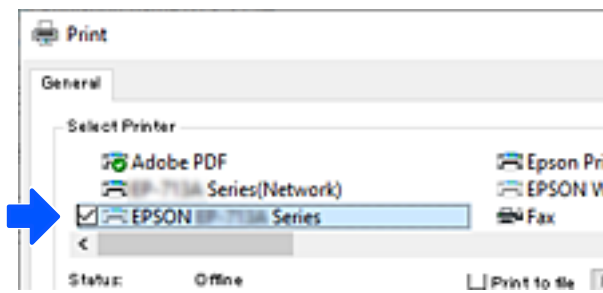

Setting a Static IP Address for the Printer

You can set up a static IP address for a printer using Web Config.

1. Access Web Config.

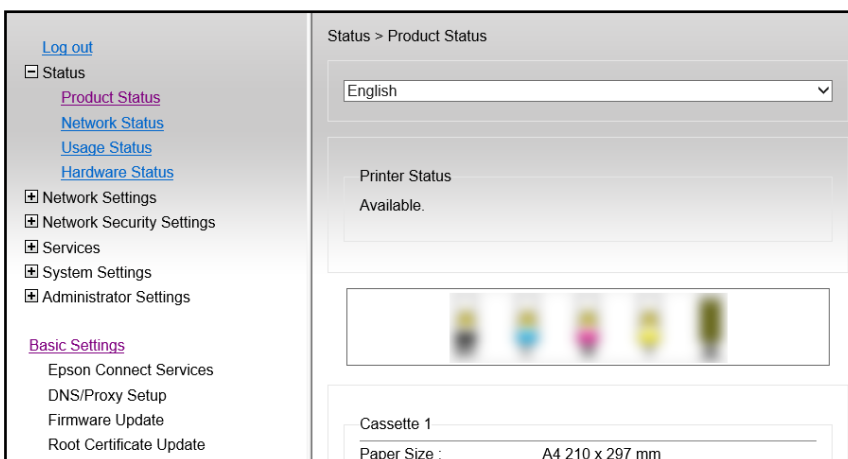

Note:

The display contents and items for Web Config differ depending on the model.

If you see the following, select **Advanced Settings** from the list at the top right of the window.

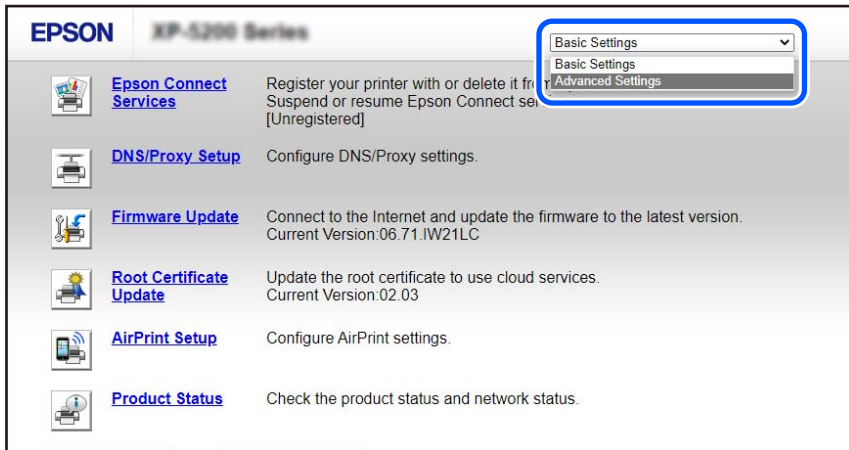

2. Login as an administrator.

Note:

The administrator password is set in advance for the **Advanced Settings** in Web Config. See the link below for details on the administrator password.

3. Select **Network Settings**.

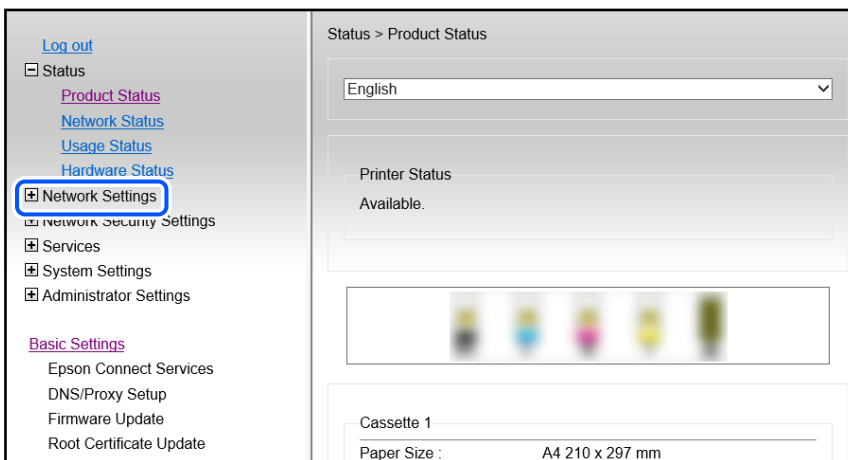

4. Select **Basic**.

Network Settings > Basic

Device Name : EPSON68500C

Location :

Note: The values in Device Name and Location are applied to multiple network protocols. Check the Services settings.

Obtain IP Address : Auto Manual

IP Address :

Subnet Mask :

Default Gateway :

DNS Server Setting : Auto Manual

Primary DNS Server :

Secondary DNS Server :

DNS Host Name Setting : Auto Manual

DNS Host Name : EPSON68500C

DNS Domain Name Setting : Auto Manual

DNS Domain Name :

Register the network interface address to DNS : Enable Disable

Proxy Server Setting : Do Not Use Use

Proxy Server :

Proxy Server Port Number :

Proxy Server User Name :

5. Select **Manual** for **Obtain IP Address**.

6. Enter the IP Address you are setting up in **IP Address**.

Set the subnet mask, default gateway, DNS server, and so on, according to your network environment.

7. Click **Next**.

8. Click **OK**.

The settings are applied.

To access Web Config again, specify the IP address you set.

Related Information

➔ [“Application for Configuring Printer Operations \(Web Config\)” on page 174](#)

Transporting and Storing the Printer

When you need to store the printer or transport it when moving or for repairs, follow the steps below to pack the printer.

1. Turn off the printer by pressing the  button.
2. Make sure the power light turns off, and then unplug the power cord.



Important:

Unplug the power cord when the power light is off. Otherwise, the print head does not return to the home position causing the ink to dry, and printing may become impossible.

3. Disconnect all cables such as the power cord and USB cable.
4. Remove all of the paper from the printer.
5. Make sure there are no originals on the printer.

6. Close the document cover if it is open.
7. Open the scanner unit with both hand until it locks.

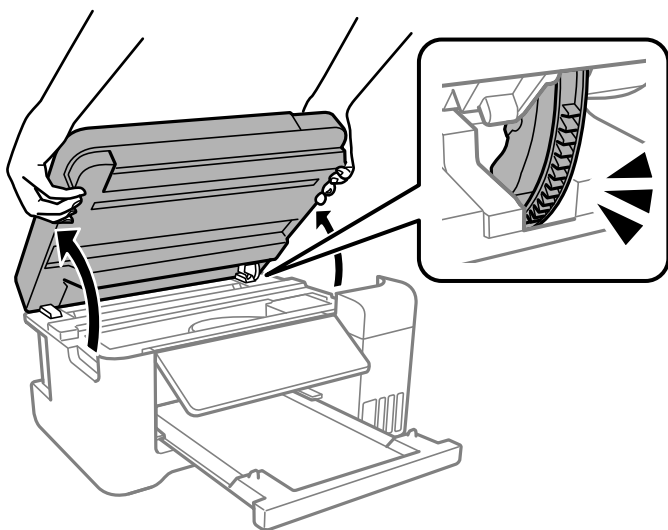

⚠ Caution:

Be careful not to trap your hand or fingers when opening or closing the scanner unit. Otherwise you may be injured.

8. Secure the print head to the case with tape.

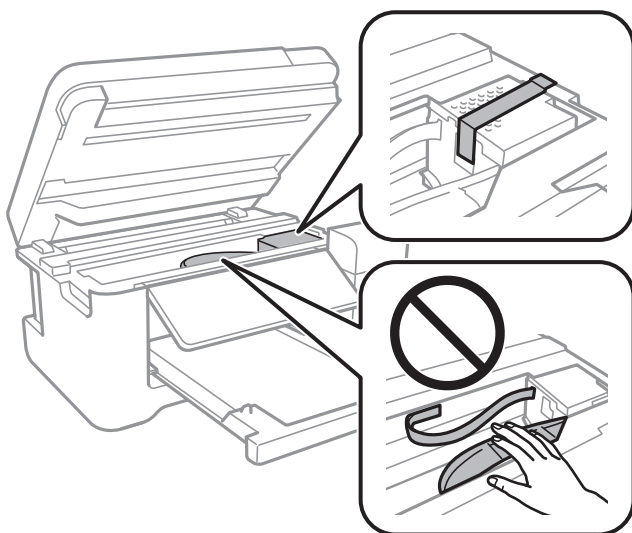

9. Make sure to install the cap onto the ink tank securely.

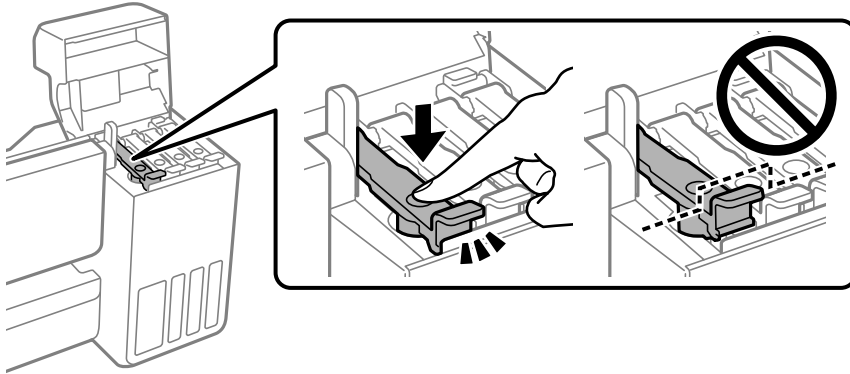

10. Close the ink tank cover securely.

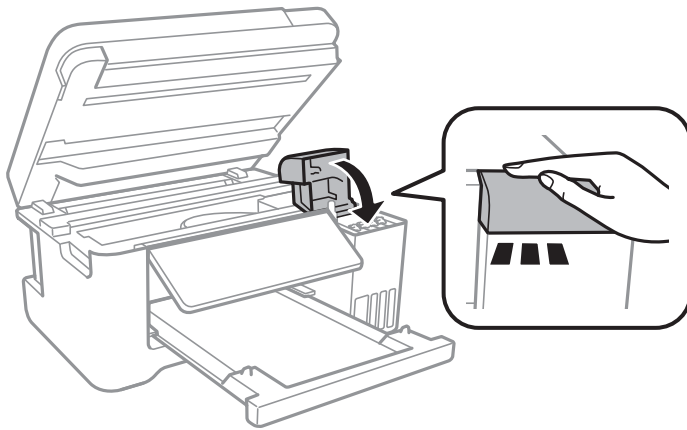

11. Close the scanner unit.

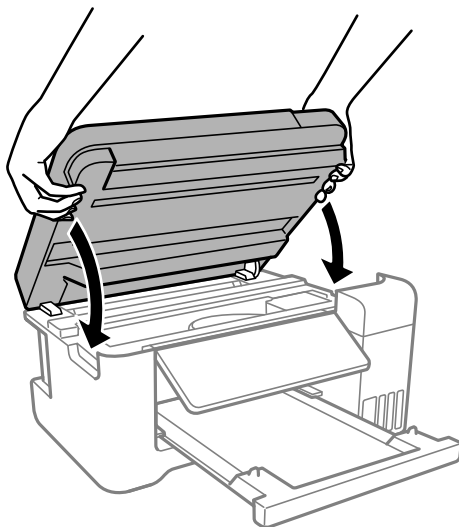

Note:

The scanner unit is designed to close slowly and resist a little as a precaution against catching fingers. Continue to close even if you feel some resistance.

12. Prepare to pack the printer as shown below.

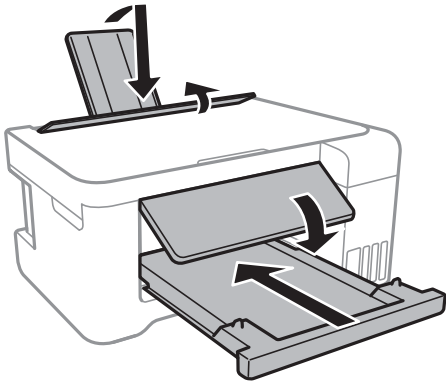

13. Place the printer in the plastic bag and fold it closed.
14. Pack the printer in its box using the protective materials.

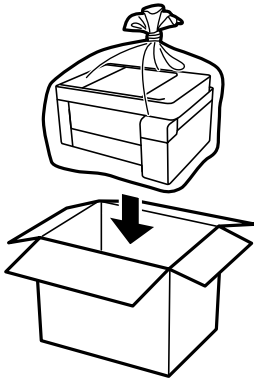

! **Important:**

- ❑ When storing or transporting the printer, place the printer in the plastic bag and fold it closed. Avoid tilting the printer, placing it vertically, or turning it upside down; otherwise ink may leak.

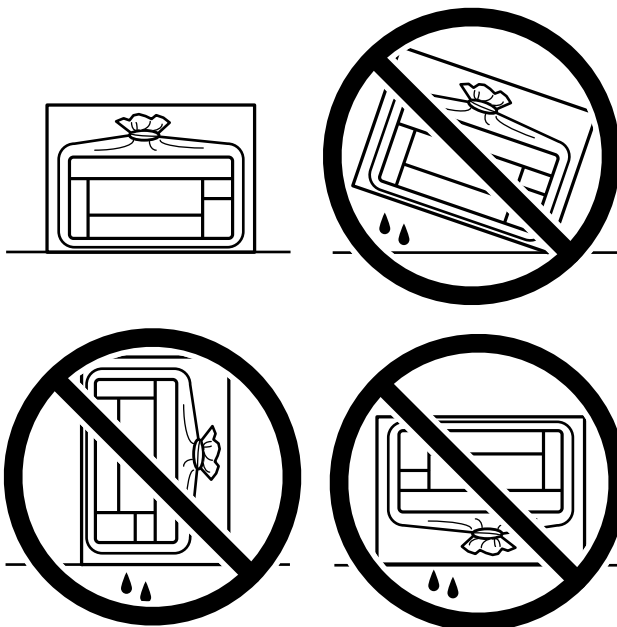

- ❑ When storing or transporting an ink bottle, do not tilt the bottle and do not subject it to impacts or temperature changes. Otherwise, ink may leak even if the cap on the ink bottle is tightened securely. Be sure to keep the ink bottle upright when tightening the cap, and take precautions to prevent ink from leaking when transporting the bottle, such as putting the bottle in a bag.
- ❑ Do not put opened ink bottles in the box with printer.



If print quality has declined the next time you print, adjust the print quality. See the related information below for details.

Related Information

➔ [“Adjusting the Print Quality” on page 76](#)

Solving Problems

Cannot Print or Scan.	116
Printing, Copying, and Scanning Quality is Poor.	127
Cannot Select Paper Type or Paper Source in Printer Driver.	145
An Error Code is Displayed on the LCD Screen.	145
Paper Gets Jammed.	146
It is Time to Refill the Ink.	150
It is Time to Replace the Maintenance Box.	156
Cannot Operate the Printer as Expected.	160
Cannot Solve Problem.	165

Cannot Print or Scan

Problem Solving

Read this section if you cannot print or scan as expected or if there are problems when printing. See the following for solutions to some common problems.

Is the printer on?

- Make sure the printer is turned on.
- Make sure the power cord is correctly connected.

Related Information

- ➔ [“Power Does Not Turn On” on page 160](#)
- ➔ [“Cannot Solve Problem” on page 165](#)

Is any paper jammed in the printer?

If paper is jammed in the printer, it cannot start printing. Remove the jammed paper from the printer.

Related Information

- ➔ [“Paper Gets Jammed” on page 146](#)

Is the printer itself working properly?

- If an error message is displayed on the LCD screen, check the error.
- Print a status sheet and use it to check if the printer itself can print properly.

Related Information

- ➔ [“An Error Code is Displayed on the LCD Screen” on page 145](#)

Are you having connection problems?

- Make sure the cables are properly connected for all connections.
- Make sure that any network device (router, hub) or USB hub that you use is operating normally.
- If you have a Wi-Fi connection, make sure that the Wi-Fi connection settings are correct.
- If you have a network connection, check the network that your computer and printer are connected to, and make sure that the names of the networks match.

Related Information

- ➔ [“The Printer Cannot Connect to the Network” on page 121](#)

- ➔ [“The Printer Cannot Connect by USB” on page 120](#)
- ➔ [“Checking the Printer’s Network Connection Status \(Network Connection Report\)” on page 96](#)

Has print data been sent correctly?

- Make sure there is no print data standing by from a previous job.
- Check the printer driver to make sure the printer is not offline.

Related Information

- ➔ [“There is still a job waiting to be printed.” on page 118](#)
- ➔ [“The printer is paused or offline.” on page 118](#)

The Application or Printer Driver do not Work Properly

Cannot Print Even Though a Connection has been Established (Windows)

One of the following situations may be the cause.

■ There is a problem with the software or data.

Solutions

- Make sure a genuine Epson printer driver (EPSON XXXXX) is installed. If a genuine Epson printer driver is not installed, the available functions are limited. We recommend using a genuine Epson printer driver.
 - If you are printing a large image, the computer may run out of memory. Print the image at a lower resolution or a smaller size.
 - You may be able to clear the problem by updating the software to the latest version. To check the software status, use the software update tool.
 - If you have tried all of the solutions and have not solved the problem, try uninstalling and then reinstalling the printer driver.
- ➔ [“Checking if a genuine Epson printer driver is installed - Windows” on page 89](#)
 - ➔ [“Checking if a genuine Epson printer driver is installed - Mac OS” on page 91](#)
 - ➔ [“Installing the Applications Separately” on page 88](#)
 - ➔ [“Application for Updating Software and Firmware \(Epson Software Updater\)” on page 175](#)

■ There is a problem with the printer's status.

Solutions

Click **EPSON Status Monitor 3** on the printer driver's **Maintenance** tab, and then check the printer status. If **EPSON Status Monitor 3** is disabled, click **Extended Settings** on the **Maintenance** tab, and then select **Enable EPSON Status Monitor 3**.

There is still a job waiting to be printed.

Solutions

Click **Print Queue** on the printer driver's **Maintenance** tab. If unnecessary data remains, select **Cancel all documents** from the **Printer** menu.

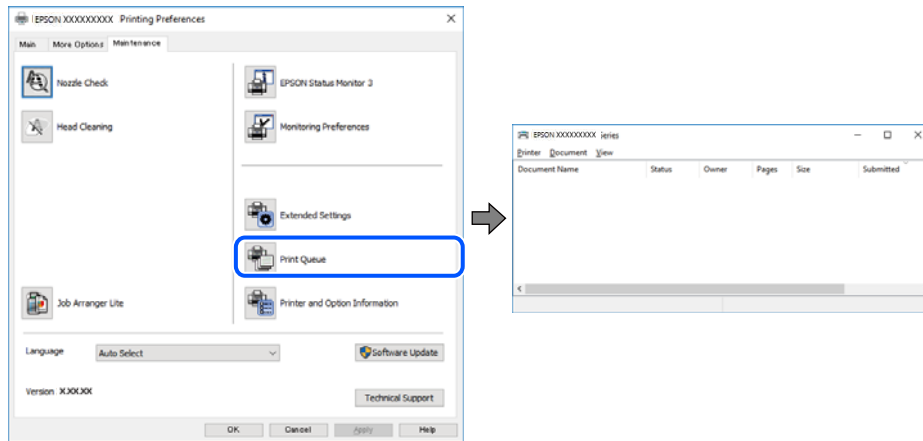

The printer is paused or offline.

Solutions

Click **Print Queue** on the printer driver's **Maintenance** tab.
If the printer is paused or offline, clear the related setting from the **Printer** menu.

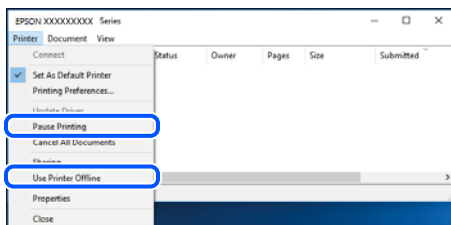

The printer is not selected as the default printer.

Solutions

Right-click the printer icon in **Control Panel > View devices and printers** (or **Printers**, or **Printers and Faxes**) and click **Set as default printer**.

Note:

If there are multiple printer icons, select the correct one based on the connection type, as described below.

USB connection: EPSON XXXX Series

Network connection: EPSON XXXX Series (network)

If you install the printer driver multiple times, copies of the printer driver may be created. If copies such as "EPSON XXXX Series (copy 1)" are created, right-click the copied driver icon, and then click **Remove Device**.

The printer port is not set correctly.

Solutions

Click **Print Queue** on the printer driver's **Maintenance** tab.

Make sure the printer port is set correctly as shown below in **Properties** > **Ports** from the **Printer** menu.

USB connection: **USBXXX**, Network connection: **EpsonNet Print Port**

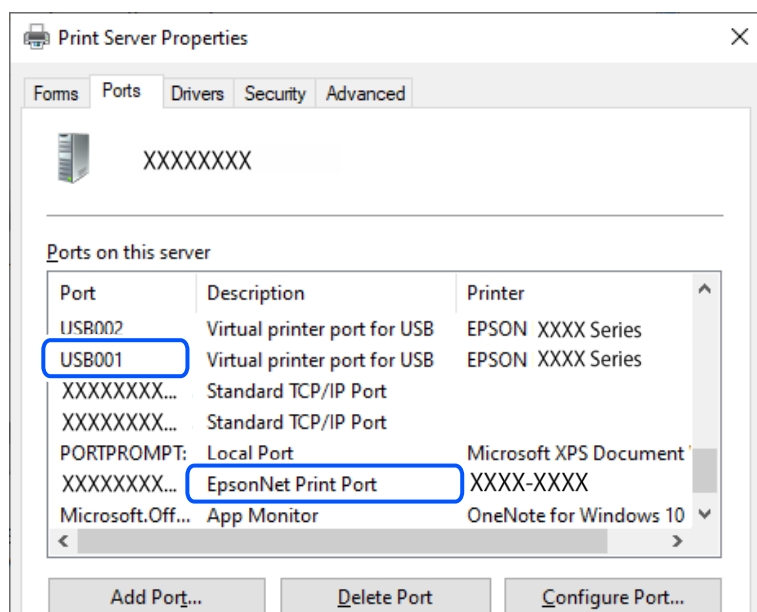

Cannot Print Even Though a Connection has been Established (Mac OS)

One of the following situations may be the cause.

There is a problem with the software or data.

Solutions

- Make sure a genuine Epson printer driver (EPSON XXXXX) is installed. If a genuine Epson printer driver is not installed, the available functions are limited. We recommend using a genuine Epson printer driver.
 - If you are printing a large image, the computer may run out of memory. Print the image at a lower resolution or a smaller size.
 - You may be able to clear the problem by updating the software to the latest version. To check the software status, use the software update tool.
 - If you have tried all of the solutions and have not solved the problem, try uninstalling and then reinstalling the printer driver.
- ➔ [“Checking if a genuine Epson printer driver is installed - Windows” on page 89](#)
- ➔ [“Checking if a genuine Epson printer driver is installed - Mac OS” on page 91](#)
- ➔ [“Installing the Applications Separately” on page 88](#)
- ➔ [“Application for Updating Software and Firmware \(Epson Software Updater\)” on page 175](#)

There is a problem with the printer's status.

Solutions

Make sure the printer status is not set to **Pause**.

Select **System Preferences** (or **System Settings**) from the **Apple** menu > **Printers & Scanners** (or **Print & Scan** or **Print & Fax**), and then double-click the printer. If the printer is paused, click **Resume**.

Cannot Print Even Though a Connection has been Established (iOS)

One of the following situations may be the cause.

■ Paper Setup Auto Display is disabled.

Solutions

Enable **Paper Setup Auto Display** in the following menu on the LCD screen.

Paper Source Settings > Paper Setup Auto Display

■ AirPrint is disabled.

Solutions

Enable the AirPrint setting in Web Config.

➔ [“Application for Configuring Printer Operations \(Web Config\)” on page 174](#)

Cannot Scan Even Though a Connection has been Correctly Established

■ Scanning at a high resolution over a network.

Solutions

Try scanning at a lower resolution.

The Printer Cannot Connect by USB

One of the following situations may be the cause.

■ The USB cable is not plugged into the USB inlet correctly.

Solutions

Connect the USB cable securely to the printer and the computer.

■ There is a problem with the USB hub.

Solutions

If you are using a USB hub, try to connect the printer directly to the computer.

■ There is a problem with the USB cable or the USB inlet.

Solutions

Connect the USB cable to a different port, or change the USB cable.

■ The printer is connected to a SuperSpeed USB port.

Solutions

If you connect the printer to a SuperSpeed USB port using a USB 2.0 cable, a communication error may occur on some computers. In this case, reconnect the printer using one of the following methods:

- Use a USB 3.0 cable (supported models only).
- Connect to a Hi-Speed USB port on the computer.

- ❑ Connect to a SuperSpeed USB port other than the port that generated the communication error.

➔ [“Interface Specifications” on page 183](#)

The Printer Cannot Connect to the Network

Main causes and solutions for network connection problems

Check the following to see if there is a problem with the operation or settings for the connected device.

■ Check the cause of the printer network connection failure.

Solutions

Print out the network connection check report to see the issue and check the recommended solutions.

See the following related information for details on reading the network connection check report.

Note:

If you want to check more information on the network settings, print a network status sheet.

➔ [“Checking the Printer's Network Connection Status \(Network Connection Report\)” on page 96](#)

➔ [“Messages and Solutions on the Network Connection Report” on page 97](#)

■ Use the Epson Printer Connection Checker to improve the connection to the computer. (Windows)

Solutions

You may be able to solve the problem depending on the results of the check.

1. Double-click the **Epson Printer Connection Checker** icon on the desktop.

Epson Printer Connection Checker starts.

If there is no icon on the desktop, follow the methods below to start Epson Printer Connection Checker.

- ❑ Windows 11

Click the start button, and then select **All apps > Epson Software > Epson Printer Connection Checker**.

- ❑ Windows 10

Click the start button, and then select **Epson Software > Epson Printer Connection Checker**.

- ❑ Windows 8.1/Windows 8

Enter the application name in the search charm, and then select the displayed icon.

- ❑ Windows 7

Click the start button, and then select **All Programs > Epson Software > Epson Printer Connection Checker**.

2. Follow the on-screen instructions.

Note:

If the printer name is not displayed, install a genuine Epson printer driver.

[“Checking if a genuine Epson printer driver is installed - Windows” on page 89](#)

When you have identified the problem, follow the solution displayed on the screen.

If you cannot solve the problem, see the information at the links below based on your situation.

- The printer is not recognized over a network connection

[“Checking the Printer's Network Connection Status \(Network Connection Report\)” on page 96](#)

- The printer is recognized, but printing cannot be performed.

[“Cannot Print Even Though a Connection has been Established \(Windows\)” on page 117](#)

■ **Something is wrong with the network devices for Wi-Fi connection.**

Solutions

Try the following if you can reset the wireless LAN router in your environment:

Turn off the devices you want to connect to the network. Wait for about 10 seconds, and then turn on the devices in the following order: wireless router, computer or mobile devices, and then printer. Move the printer and computer or mobile devices closer to the wireless router to help with radio wave communication, and then try to configure network settings again.

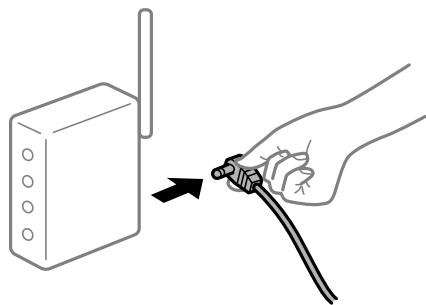

■ **Devices cannot receive signals from the wireless router because they are too far apart.**

Solutions

After moving the computer or the mobile devices and the printer closer to the wireless router, turn off the wireless router, and then turn it back on.

■ **When changing the wireless router, the settings do not match the new router.**

Solutions

Reconfigure the settings so that they match the new wireless router.

➔ [“Resetting the Network Connection” on page 91](#)

■ **The SSIDs connected from the computer or mobile devices and computer are different.**

Solutions

When you are using multiple wireless routers at the same time or the wireless router has multiple SSIDs and devices are connected to different SSIDs, you cannot connect to the wireless router.

- ❑ Example of connecting to different SSIDs

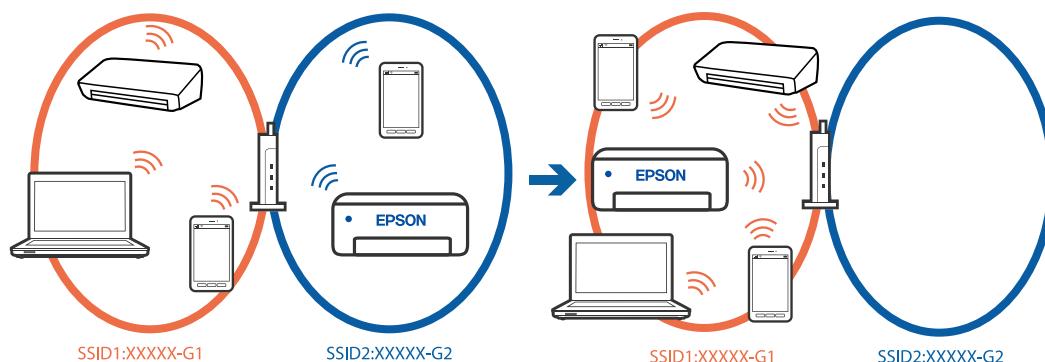

- ❑ Example of connecting to SSIDs with a different frequency range

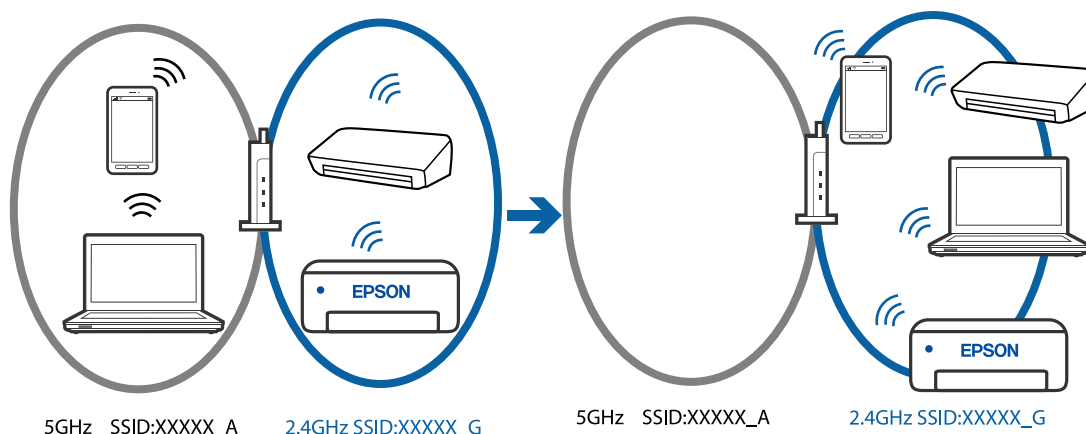

Connect the computer or mobile devices to the same SSID as the printer.

- ❑ Check the SSID that the printer is connected to by printing out the network connection check report.
- ❑ On all of the computers and mobile devices you want to connect to the printer, check the name of the Wi-Fi or network you are connected to.
- ❑ If the printer and your computer or mobile devices are connected to different networks, reconnect the devices to the SSID that the printer is connected to.

■ A privacy separator on the wireless router is enabled.

Solutions

Most wireless routers have a separator function that blocks communication between devices within the same SSID. If you cannot communicate between the printer and the computer or mobile devices even if they are connected to the same network, disable the separator function on the wireless router. See the manual provided with the wireless router for details.

■ The IP address is incorrectly assigned.

Solutions

If the IP address assigned to the printer is 169.254.XXX.XXX, and the subnet mask is 255.255.0.0, the IP address may not be assigned correctly.

Print the network connection report, and then check the IP address and the subnet mask assigned to the printer. To print a network connection report, select **Settings > Network Settings > Connection Check**.

Reboot the wireless router or reset the network settings for the printer.

➔ [“Setting a Static IP Address for the Printer” on page 108](#)

■ **The device connected to the USB 3.0 port causes radio frequency interference.**

Solutions

When you connect a device to the USB 3.0 port on a Mac, radio frequency interference may occur. Try the following if you cannot connect to wireless LAN (Wi-Fi) or if operations become unstable.

- Place the device that is connected to the USB 3.0 port further away from the computer.

■ **There is a problem with the network settings on the computer or mobile devices.**

Solutions

Try accessing any website from your computer or mobile devices to make sure that your device's network settings are correct. If you cannot access any websites, there is a problem on the computer or mobile devices.

Check the network connection for the computer or mobile devices. See the documentation provided with the computer or mobile devices for details.

Paper Does Not Feed Properly

Points to Check

One of the following situations may be the cause.

■ **The installation location is inappropriate.**

Solutions

Place the printer on a flat surface and operate in the recommended environmental conditions.

➔ [“Environmental Specifications” on page 187](#)

■ **Unsupported paper is being used.**

Solutions

Use paper supported by this printer.

➔ [“Available Paper and Capacities” on page 168](#)

➔ [“Unavailable Paper Types” on page 171](#)

■ **Paper handling is inappropriate.**

Solutions

Follow paper handling precautions.

➔ [“Paper Handling Precautions” on page 25](#)

■ **Too many sheets are loaded in the printer.**

Solutions

Do not load more than the maximum number of sheets specified for the paper. For plain paper, do not load above the line indicated by the triangle symbol on the edge guide.

➔ [“Available Paper and Capacities” on page 168](#)

■ **The paper settings on the printer are incorrect.**

Solutions

Make sure the paper size and paper type settings match the actual paper size and paper type loaded in the printer.

➔ [“Paper Size and Type Settings” on page 26](#)

■ **The paper settings in the printer driver are incorrect.**

Solutions

Make sure the paper size and paper type settings in the printer driver match the actual paper size and paper type loaded in the printer.

Paper Feeds at a Slant

One of the following situations may be the cause.

■ **The paper is curled.**

Solutions

If the paper is curled or the edges of the paper are folded, it may touch the print head and be fed at an angle.

Place the paper on a flat surface to check if it is curled. If it is, flatten it.

■ **The paper is loaded incorrectly.**

Solutions

Load paper in the correct direction, and slide the edge guides against the edges of the paper.

➔ [“Loading Paper in the Rear Paper Feeder” on page 27](#)

Several Sheets of Paper are Fed at a Time

One of the following situations may be the cause.

■ **The paper is moist or damp.**

Solutions

Load new paper.

■ **Static electricity is causing sheets of paper to stick to each other.**

Solutions

Fan the paper before loading. If the paper still does not feed, load one sheet of paper at a time.

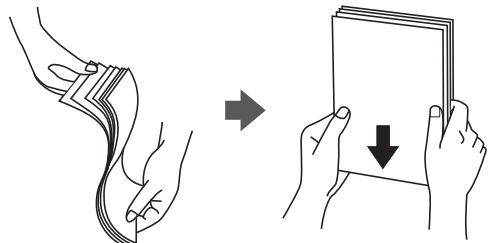

■ **Multiple sheets of paper are loaded.**

Solutions

Load one sheet of paper at a time if you have loaded several sheets of paper.

■ **Multiple sheets of paper feed at the same time during manual 2-sided printing.**

Solutions

Remove any paper that is loaded in the paper source before you reload the paper.

Paper Out Error Occurs

■ **Paper is not loaded in the center of the rear paper feeder.**

Solutions

When a paper out error occurs although paper is loaded in the rear paper feeder, reload paper in the center of the rear paper feeder.

Paper is Ejected During Printing

■ **Letterhead is not selected as the paper type.**

Solutions

When you load letterhead paper (paper on which information such as the sender's name or corporation name are pre-printed in the header), select **Letterhead** as the paper type setting.

Printing, Copying, and Scanning Quality is Poor

Print Quality is Poor

Banding or Unexpected Colors Appear, or Colors Are Missing

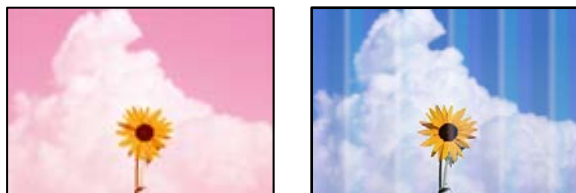

■ The print head nozzles may be clogged.

Solutions

Use the **Print Quality Adjustment** feature. If you have not used the printer for a long time, the print head nozzles may be clogged and ink drops may not be discharged.

➔ [“Adjusting the Print Quality” on page 76](#)

Print Quality is Poor with Black Ink

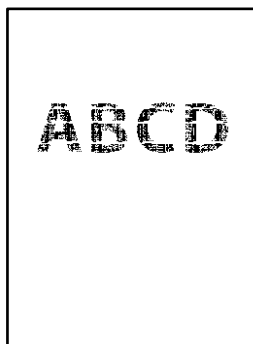

■ The print head nozzles may be clogged.

Solutions

- Use the **Print Quality Adjustment** feature. If you have not used the printer for a long time, the print head nozzles may be clogged and ink drops may not be discharged.

[“Adjusting the Print Quality” on page 76](#)

- If you cannot solve the problem using head cleaning, you can print immediately with a mixture of color inks to create composite black by changing the following settings in Windows.

Click **Extended Settings** on the printer driver's **Maintenance** tab. If you select **Use a Mixture of Color Inks to Create Black**, you can print at **Standard** print quality when the **Paper Type** is **Plain paper**, **Letterhead**, or **Envelope**.

Note that this feature cannot solve nozzle clogging. To solve nozzle clogging, contact Epson support.

➔ [“Contacting Epson Support” on page 190](#)

Colored Banding Appears at Intervals of Approximately 2.5 cm



The following causes can be considered.

■ The paper type in the printer settings is incorrect.

Solutions

Make sure the paper type in the printer settings matches the actual paper type.

➔ [“List of Paper Type” on page 26](#)

■ The print quality setting is too low.

Solutions

When printing on plain paper, use a higher quality setting.

Windows

Select **High** from **Quality** on the printer driver's **Main** tab.

Mac OS

Select **Fine** as **Print Quality** from the print dialog's **Print Settings** menu.

■ The print head is out of alignment.

Solutions

Align the print head using the **Print Quality Adjustment** feature.

➔ [“Adjusting the Print Quality” on page 76](#)

Blurry Prints, Vertical Banding, or Misalignment



enthalten alle
Aufdruck. W
↓ 5008 "Regel

One of the following situations may be the cause. Try the solutions in the order shown.

■ The print head is out of alignment.

Solutions

Align the print head using the **Print Quality Adjustment** feature.

➔ [“Adjusting the Print Quality” on page 76](#)

■ The bidirectional printing setting is enabled.

Solutions

If print quality does not improve even after aligning the print head, disable the bidirectional setting.

During bidirectional (or high speed) printing, the print head prints while moving in both directions, and vertical lines may be misaligned. Disabling this setting may slow down printing speed but improve print quality.

Windows

Clear **Bidirectional Printing** on the printer driver's **More Options** tab.

Mac OS

Select **System Preferences** (or **System Settings**) from the Apple menu > **Printers & Scanners** (or **Print & Scan** or **Print & Fax**), and then select the printer. Click **Options & Supplies** > **Options** (or **Driver**). Select **Off** as the **Bidirectional Printing** setting.

The Printout Comes Out as a Blank Sheet

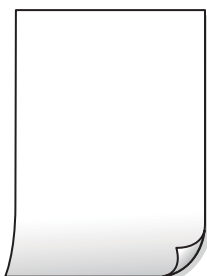

■ The print head nozzles may be clogged.

Solutions

Use the **Print Quality Adjustment** feature. If you have not used the printer for a long time, the print head nozzles may be clogged and ink drops may not be discharged.

➔ [“Adjusting the Print Quality” on page 76](#)

■ The paper size in the print settings is incorrect.

Solutions

Make sure the paper size in the print settings matches the actual paper size.

■ Multiple sheets of paper are fed into the printer at the same time.

Solutions

See the following to prevent multiple sheets of paper from being fed into the printer at the same time.

➔ [“Several Sheets of Paper are Fed at a Time” on page 125](#)

Printed at an Angle



■ The paper is curled.

Solutions

If the paper is curled or the edges of the paper are folded, it may touch the print head and be fed at an angle.

Place the paper on a flat surface to check if it is curled. If it is, flatten it.

■ The paper is loaded incorrectly.

Solutions

Load paper in the correct direction, and slide the edge guides against the edges of the paper.

➔ [“Loading Paper in the Rear Paper Feeder” on page 27](#)

Paper Is Smeared or Scuffed



One of the following situations may be the cause.

■ The paper is loaded incorrectly.

Solutions

When horizontal banding (perpendicular to the printing direction) appears, or the top or bottom of the paper is smeared, load paper in the correct direction and slide the edge guides to the edges of the paper.

➔ [“Loading Paper in the Rear Paper Feeder” on page 27](#)

■ The paper path is smeared.

Solutions

When vertical banding (parallel to the printing direction) appears, or the paper is smeared, clean the paper path.

➔ [“Cleaning the Paper Path for Ink Smears” on page 81](#)

■ The paper is curled.

Solutions

Place the paper on a flat surface to check if it is curled. If it is, flatten it.

■ The print head is rubbing the surface of the paper.

Solutions

When printing on thick paper, the print head is close to the printing surface and the paper may be scuffed. In this case, enable the reduce scuff setting. If you enable this setting, print quality may decline or printing may slow down.

Windows

Click **Extended Settings** on the printer driver's **Maintenance** tab, and then select **Short Grain Paper**.

Mac OS

Select **System Preferences** (or **System Settings**) from the Apple menu > **Printers & Scanners** (or **Print & Scan** or **Print & Fax**), and then select the printer. Click **Options & Supplies** > **Options** (or **Driver**). Select **On** as the **Thick paper and envelopes** setting.

■ The back of the paper was printed before the side that had already been printed was dry.

Solutions

When performing manual 2-sided printing, make sure that the ink is completely dry before reloading the paper.

■ When printing using automatic 2-sided printing, the print density is too high and the drying time is too short.

Solutions

When using the automatic 2-sided printing feature and printing high density data such as images and graphs, lower the print density and increase the drying time.

Printed Photos are Sticky



■ The wrong side of the photo paper was used.

Solutions

Make sure the paper size in the printer settings matches the actual paper size. If you print on the wrong side of the photo paper, you need to clean the paper path.

Images or Photos Contain Unexpected Colors



One of the following situations may be the cause.

■ The print head nozzles may be clogged.

Solutions

Use the **Print Quality Adjustment** feature. If you have not used the printer for a long time, the print head nozzles may be clogged and ink drops may not be discharged.

➔ [“Adjusting the Print Quality” on page 76](#)

■ Color correction has been applied.

Solutions

When printing from the Windows printer driver, the Epson auto photo adjustment setting is applied by default depending on the paper type. Try changing the setting.

On the **More Options** tab, select **Custom** in **Color Correction**, and then click **Advanced**. Change the **Scene Correction** setting from **Automatic** to any other option. If changing the setting does not work, use any color correction method other than **PhotoEnhance** in **Color Management**.

Colors in the Printout Differ from Those on the Display



■ The color properties for the display device you are using have not been adjusted correctly.

Solutions

Display devices such as computer screens have their own display properties. If the display is unbalanced, the image is not displayed with proper brightness and colors. Adjust the properties of the display device, then perform the following.

Windows

Access the printer driver window, select **Custom** as the **Color Correction** setting on the **More Options** tab, and then click **Advanced**. Select **EPSON Standard** as the **Color Mode** setting.

Mac OS

Access the print dialog. Select **Color Options** from the pop-up menu, and then click the arrow next to **Advanced Settings**. Select **EPSON Standard** as the **Mode** setting.

■ The display device is reflecting external light.

Solutions

Avoid direct sunlight and view the image in an environment where the appropriate lighting is assured.

■ The display device has a high resolution.

Solutions

Colors may differ from what you see on mobile devices with high-resolution displays.

■ The display device and the printer have a different process of producing colors.

Solutions

Colors on a display are not quite identical to those on paper because the display device and the printer have a different process of producing colors. Adjust the color properties so that the colors match more closely.

Cannot Print Without Margins



■ The borderless feature is not enabled in the print settings.

Solutions

Enable the borderless feature in the print settings. If you select a paper type that does not support borderless printing, you cannot select **Borderless**. Select a paper type that supports borderless printing.

Windows

Select **Borderless** on the printer driver's **Main** tab.

Mac OS

Select a borderless paper size from **Paper Size**.

The Edges of the Image are Cropped During Borderless Printing



Because the image is slightly enlarged, the area beyond the paper size boundaries is cropped.

Solutions

Select a smaller enlargement setting.

- Windows

Click **Settings** next to the **Borderless** checkbox on the printer driver's **Main** tab, and then change the setting.

- Mac OS

Change the **Expansion** setting from the print dialog's **Print Settings** menu.

Aspect ratios of the image data and paper size are different.

Solutions

If the aspect ratios of the image data and paper size are different, the long side of the image is cropped if it extends beyond the long side of the paper.

The Position, Size, or Margins of the Printout Are Incorrect

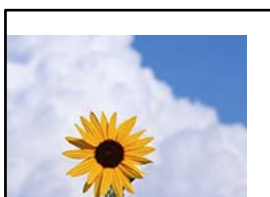

One of the following situations may be the cause.

The paper is loaded incorrectly.

Solutions

Load paper in the correct direction, and slide the edge guides against the edges of the paper.

➔ [“Loading Paper in the Rear Paper Feeder” on page 27](#)

The paper size in the printer settings is incorrect.

Solutions

Make sure the paper size in the printer settings matches the actual paper size.

■ The invert option is enabled in the print settings.

Solutions

Clear any mirror image settings in the printer driver or the application.

Windows

Clear **Mirror Image** on the printer driver's **More Options** tab.

Mac OS

Clear **Mirror Image** from the print dialog's **Print Settings** menu.

Mosaic-Like Patterns Appear in the Printout



■ Low resolution images or photos were printed.

Solutions

When printing images or photos, print using high-resolution data. Images on web sites are often low resolution even if they look good enough on the display, and so print quality may decline when you print them.

Copy Quality is Poor

Banding or Unexpected Colors Appear, or Colors Are Missing



■ The print head nozzles may be clogged.

Solutions

Use the **Print Quality Adjustment** feature. If you have not used the printer for a long time, the print head nozzles may be clogged and ink drops may not be discharged.

➔ [“Adjusting the Print Quality” on page 76](#)

■ You copied in draft mode.

Solutions

Change the print quality setting to something other than draft mode, and then copy again.

Note:

For users in Western Europe, draft mode is not available.

Colored Banding Appears at Intervals of Approximately 2.5 cm



The following causes can be considered.

■ The paper type in the printer settings is incorrect.

Solutions

Make sure the paper type in the printer settings matches the actual paper type.

➔ [“List of Paper Type” on page 26](#)

■ The print quality setting is too low.

Solutions

When copying on plain paper, use a higher quality setting.

Select **High** as the **Quality** setting.

➔ [“Quality:” on page 63](#)

■ The print head is out of alignment.

Solutions

Align the print head using the **Print Quality Adjustment** feature.

➔ [“Adjusting the Print Quality” on page 76](#)

Blurry Copies, Vertical Banding, or Misalignment



enthalten alle
Aufdruck. W
↓ 5008 "Regel

One of the following situations may be the cause.

■ **The print head is out of alignment.**

Solutions

Align the print head using the **Print Quality Adjustment** feature.

➔ [“Adjusting the Print Quality” on page 76](#)

The Printout Comes Out as a Blank Sheet

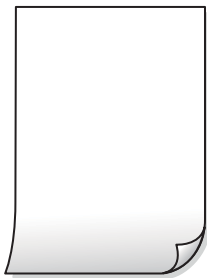

■ **The print head nozzles may be clogged.**

Solutions

Use the **Print Quality Adjustment** feature. If you have not used the printer for a long time, the print head nozzles may be clogged and ink drops may not be discharged.

➔ [“Adjusting the Print Quality” on page 76](#)

■ **The paper size in the print settings is incorrect.**

Solutions

Make sure the paper size in the print settings matches the actual paper size.

■ **Multiple sheets of paper are fed into the printer at the same time.**

Solutions

See the following to prevent multiple sheets of paper from being fed into the printer at the same time.

➔ [“Several Sheets of Paper are Fed at a Time” on page 125](#)

Paper Is Smearred or Scuffed



One of the following situations may be the cause.

■ The paper is loaded incorrectly.

Solutions

When horizontal banding (perpendicular to the printing direction) appears, or the top or bottom of the paper is smeared, load paper in the correct direction and slide the edge guides to the edges of the paper.

➔ [“Loading Paper in the Rear Paper Feeder” on page 27](#)

■ The paper path is smeared.

Solutions

When vertical banding (parallel to the printing direction) appears, or the paper is smeared, clean the paper path.

➔ [“Cleaning the Paper Path for Ink Smears” on page 81](#)

■ The paper is curled.

Solutions

Place the paper on a flat surface to check if it is curled. If it is, flatten it.

Cannot Copy Without Margins



■ Borderless is not set in the print settings.

Solutions

Select **Copy > More > Borderless Copy**, and then enable the setting . If you select a paper that does not support borderless printing, you cannot enable borderless settings. Select a paper type that supports borderless printing.

The edges of the Image are Cropped During Borderless Copying



Because the image is slightly enlarged, the area beyond the paper size boundaries is cropped.

Solutions

Select a smaller enlargement setting.

Select **Copy > More > Borderless Copy > Expansion** on the control panel, and then change the setting.

The Position, Size, or Margins of the Copies are Incorrect

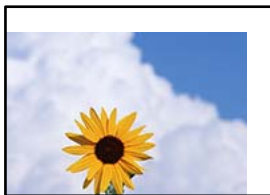

One of the following situations may be the cause.

The paper is loaded incorrectly.

Solutions

Load paper in the correct direction, and slide the edge guides against the edges of the paper.

➔ [“Loading Paper in the Rear Paper Feeder” on page 27](#)

The originals are not placed correctly.

Solutions

Make sure the original is placed correctly against the alignment marks.

If the edge of the scanned image is missing, move the original slightly away from the edge of the scanner glass.

➔ [“Placing Originals” on page 33](#)

There is dust or dirt on the scanner glass.

Solutions

When placing the originals on the scanner glass, remove any dust or dirt from the originals, and clean the scanner glass. If there is dust or stains on the glass, the copy area may extend to include the dust or stains, resulting in the wrong copying position or small images.

➔ [“Cleaning the Scanner Glass” on page 81](#)

The paper size in the printer settings is incorrect.

Solutions

Make sure the paper size in the printer settings matches the actual paper size.

Uneven Colors, Smears, Dots, or Straight Lines Appear in the Copied Image



One of the following situations may be the cause.

■ The paper path is dirty.

Solutions

Clean the paper path.

➔ [“Cleaning the Paper Path for Ink Smears” on page 81](#)

■ There is dust or dirt on the originals or the scanner glass.

Solutions

Remove any dust or dirt from the originals, and clean the scanner glass.

➔ [“Cleaning the Scanner Glass” on page 81](#)

■ The original was pressed with too much force.

Solutions

If you press with too much force, blurring, smudges, and spots may occur.

Do not press with too much force on the original or the document cover.

➔ [“Placing Originals” on page 33](#)

■ The copy density setting is too high.

Solutions

Lower the copy density setting.

➔ [“More Menu Options for Copying” on page 62](#)

Moiré (Cross-Hatch) Patterns Appear in the Copied Image

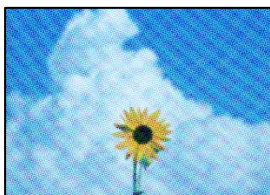

If the original is a printed document such as a magazine or a catalog, a dotted moiré pattern appears.

Solutions

Change the reduce and enlarge setting. If a moiré pattern still appears, place the original at a slightly different angle.

➔ [“More Menu Options for Copying” on page 62](#)

An Image of the Reverse Side of the Original Appears in the Copied Image



One of the following situations may be the cause.

When scanning thin originals, images on the back may be scanned at the same time.

Solutions

Place the original on the scanner glass and then place a piece of black paper over it.

➔ [“Placing Originals on the Scanner Glass” on page 34](#)

The copy density setting is too high.

Solutions

Lower the copy density setting.

➔ [“More Menu Options for Copying” on page 62](#)

Scanned Image Problems

Uneven Colors, Dirt, Spots, Appear when Scanning from the Scanner Glass



There is dust or dirt on the originals or the scanner glass.

Solutions

Remove any dust or dirt from the originals, and clean the scanner glass.

➔ [“Cleaning the Scanner Glass” on page 81](#)

■ **The original was pressed with too much force.**

Solutions

If you press with too much force, blurring, smudges, and spots may occur.

Do not press with too much force on the original or the document cover.

➔ [“Placing Originals” on page 33](#)

An Image of the Reverse Side of the Original Appears in the Scanned Image



■ **When scanning thin originals, images on the back may be scanned at the same time.**

Solutions

Place the original on the scanner glass and then place a piece of black paper over it.

Cannot Scan the Correct Area on the Scanner Glass

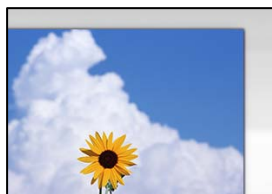

■ **The originals are not placed correctly.**

Solutions

- Make sure the original is placed correctly against the alignment marks.
- If the edge of the scanned image is missing, move the original slightly away from the edge of the scanner glass.

➔ [“Placing Originals” on page 33](#)

■ **There is dust or dirt on the scanner glass.**

Solutions

Remove any dust or dirt from the scanner glass and document cover. If there is any dust or dirt around the original, the scanning range expands to include it.

➔ [“Cleaning the Scanner Glass” on page 81](#)

When scanning multiple originals using Epson ScanSmart, there is not enough of a gap between the originals.

Solutions

When placing multiple originals on the scanner glass, make sure there is a gap of at least 20 mm (0.8 in.) between the originals.

Cannot Solve Problems in the Scanned Image

Check the following if you have tried all of the solutions and have not solved the problem.

There are problems with the scanning software settings.

Solutions

Use Epson Scan 2 Utility to initialize the settings for the scanner software.

Note:

Epson Scan 2 Utility is an application supplied with the scanner software.

Note:

*For Windows Server operating systems, make sure the **Desktop Experience** feature is installed.*

1. Start the Epson Scan 2 Utility.

Windows 11

Click the start button, and then select **All apps > EPSON > Epson Scan 2 Utility**.

Windows 10/Windows Server 2022/Windows Server 2019/Windows Server 2016

Click the start button, and then select **EPSON > Epson Scan 2 Utility**.

Windows 8.1/Windows 8/Windows Server 2012 R2/Windows Server 2012

Enter the application name in the search charm, and then select the displayed icon.

Windows 7/Windows Server 2008 R2/Windows Server 2008

Click the start button, and then select **All Programs > EPSON > Epson Scan 2 > Epson Scan 2 Utility**.

Mac OS

Select **Go > Applications > Epson Software > Epson Scan 2 Utility**.

2. Select the **Other** tab.

3. Click **Reset**.

If initialization does not solve the problem, uninstall and reinstall the scanner software.

➔ [“Installing the Applications Separately” on page 88](#)

Cannot Select Paper Type or Paper Source in Printer Driver

A genuine Epson printer driver has not been installed.

Solutions

If a genuine Epson printer driver (EPSON XXXXX) has not been installed, the available functions are limited. We recommend using a genuine Epson printer driver.

➔ [“Checking if a genuine Epson printer driver is installed - Windows” on page 89](#)

➔ [“Checking if a genuine Epson printer driver is installed - Mac OS” on page 91](#)

An Error Code is Displayed on the LCD Screen

A code is displayed on the LCD screen if there is an error or information that requires your attention.

Code	Situation	Solutions
E-01	A printer error has occurred.	Open the inner cover and the scanner unit, and then remove any paper or protective material inside the printer. Turn the power off and on again.
E-02	A scanner error has occurred.	Turn the power off and on again.
E-11	An ink pad needs to be replaced.	Contact Epson or an authorised Epson service provider to replace the ink pad*. It is not a user-serviceable part. However, non-printing features such as scanning are available.
W-01	A paper jam has occurred.	Remove the paper from the printer and press the button displayed on the bottom of the LCD screen to clear the error. In some cases, you need to turn the power off and on again. “Removing Jammed Paper” on page 146
W-11	An ink pad is nearing the end of its service life.	Contact Epson or an authorised Epson service provider to replace the ink pad*. It is not a user-serviceable part. The message will be displayed until the ink pad is replaced. Press the OK button to resume printing.
I-22	Set Wi-Fi from the Push Button Setup (WPS) .	Push the access point button. If there is no button on the access point, open the access point setting window, and then click the button displayed in the software.
I-23	Set Wi-Fi from the PIN Code (WPS) .	Enter the PIN code displayed on the LCD screen into the access point or computer within two minutes.
I-31	Set Wi-Fi from the Easy Connect with App .	Install the software on your computer, and then press the OK button when Wi-Fi setup starts.
I-41	Paper Setup Auto Display is disabled. Some functions cannot be used.	If Paper Setup Auto Display is disabled, you cannot use AirPrint.
I-60	Your computer may not support WSD (Web Services for Devices).	The scan to computer (WSD) feature is only available for computers running English versions of Windows 11, Windows 10, Windows 8.1, Windows 8 or Windows 7. Make sure that the printer is correctly connected to the computer.

Code	Situation	Solutions
Recovery Mode	The printer has started in recovery mode because the firmware update failed.	<p>Follow the steps below to try to update the firmware again.</p> <ol style="list-style-type: none"> 1. Connect the computer and the printer with a USB cable. <p>! Important:</p> <ul style="list-style-type: none"> <input type="checkbox"/> <i>During recovery mode, you cannot update the firmware over a network connection. You can only use a USB connection.</i> <input type="checkbox"/> <i>Use a USB 2.0 type A-B cable.</i> <ol style="list-style-type: none"> 2. Download the latest firmware from your local Epson website to your computer, and then start the update.

* In some print cycles a very small amount of surplus ink may be collected in the ink pad. To prevent ink leakage from the pad, the product is designed to stop printing when the pad has reached its limit. Whether and how often this is required will vary according to the number of pages you print using the borderless print option. The need for replacement of the pad does not mean that your printer has ceased to operate in accordance with its specifications. The printer will advise you when the pad requires replacing and this can only be performed by an authorised Epson Service provider. The Epson warranty does not cover the cost of this replacement.

Paper Gets Jammed

Check the error displayed on the control panel and follow the instructions to remove the jammed paper, including any torn pieces. Next, clear the error.



Important:

- Remove the jammed paper carefully. Removing the paper with too much force may damage the printer.*
- When removing jammed paper, avoid tilting the printer, placing it vertically, or turning it upside down; otherwise ink may leak.*

Removing Jammed Paper



Caution:

- Be careful not to trap your hand or fingers when opening or closing the scanner unit. Otherwise you may be injured.*
- Never touch the buttons on the control panel while your hand is inside the printer. If the printer starts operating, it could cause an injury. Be careful not to touch the protruding parts to avoid injury.*

1. Remove the jammed paper.

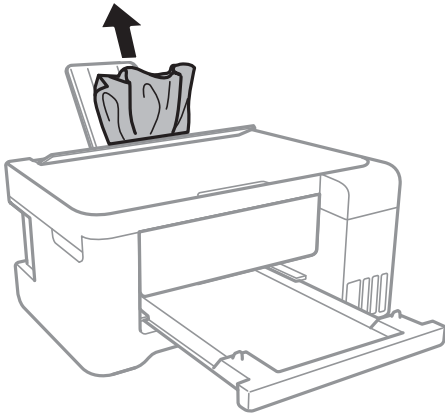

2. Remove the rear cover.

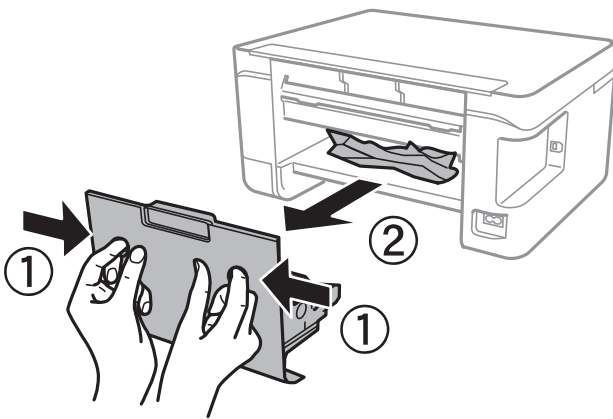

3. Remove the jammed paper.

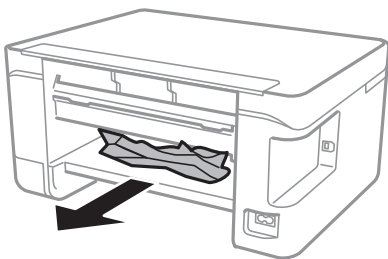

4. Remove jammed paper from the rear cover.

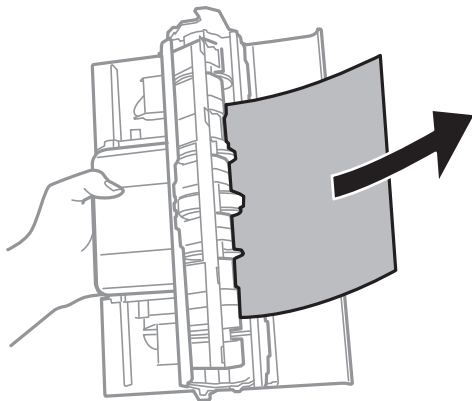

5. Insert the rear cover in the printer.
6. Close the document cover if it is open.
7. Open the scanner unit with both hand until it locks.

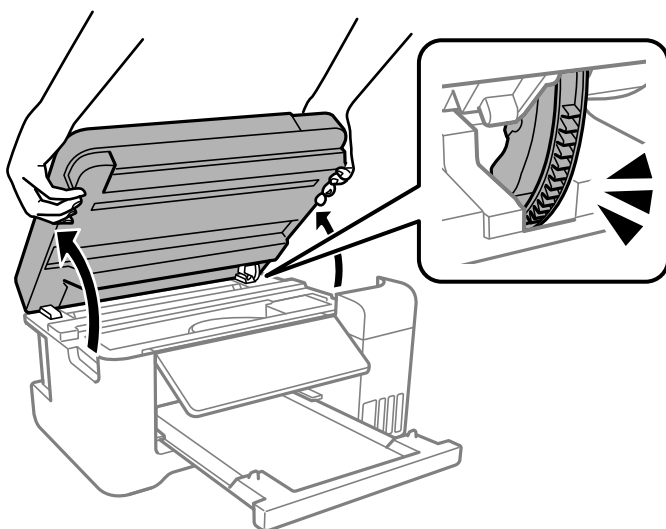

8. Remove the jammed paper.

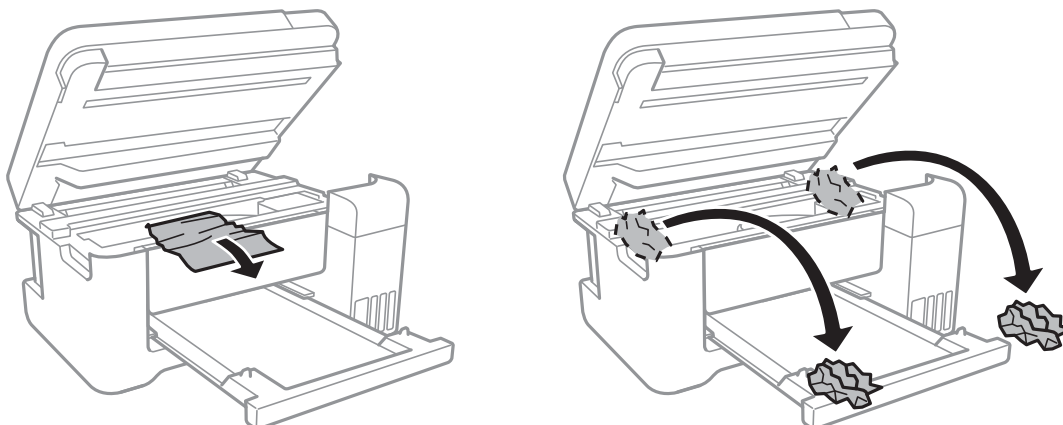

! **Important:**

Do not touch the white flat cable, translucent film, and ink tubes inside the printer. Doing so may cause a malfunction.

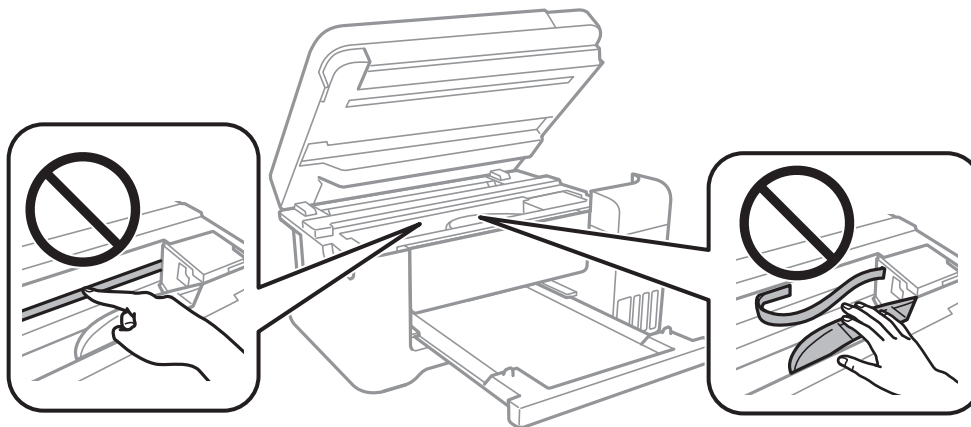

9. Close the scanner unit.

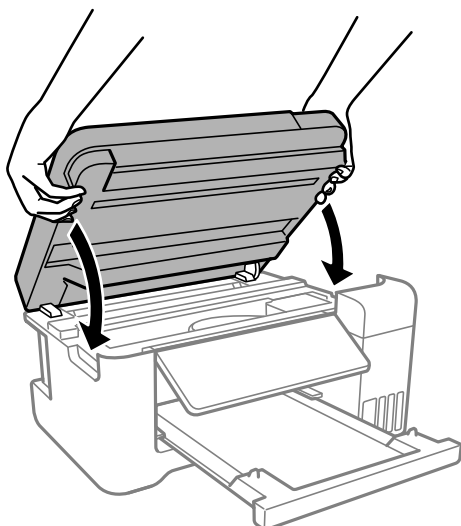

Note:

The scanner unit is designed to close slowly and resist a little as a precaution against catching fingers. Continue to close even if you feel some resistance.

Preventing Paper Jams

Check the following if paper jams occur frequently.

- Place the printer on a flat surface and operate in the recommended environmental conditions.
“[Environmental Specifications](#)” on page 187
- Use the paper supported by this printer.
“[Available Paper and Capacities](#)” on page 168
- Follow paper handling precautions.
“[Paper Handling Precautions](#)” on page 25

- Load paper in the correct direction, and slide the edge guide against the edge of the paper.
“Loading Paper in the Rear Paper Feeder” on page 27
- Do not load more than the maximum number of sheets specified for paper.
- Load one sheet of paper at a time if you have loaded several sheets of paper.
- Make sure the paper size and paper type settings match the actual paper size and paper type loaded in the printer.
“List of Paper Type” on page 26

It is Time to Refill the Ink

Ink Bottle Handling Precautions

Read the following instructions before refilling ink.

Storing precautions for ink

- Keep the ink bottles out of direct sunlight.
- Do not store the ink bottles in high or freezing temperatures.
- Epson recommends using the ink bottle before the date printed on the package.
- When storing or transporting an ink bottle, do not tilt the bottle and do not subject it to impacts or temperature changes. Otherwise, ink may leak even if the cap on the ink bottle is tightened securely. Be sure to keep the ink bottle upright when tightening the cap, and take precautions to prevent ink from leaking when transporting the bottle, such as putting the bottle in a bag.
- After bringing an ink bottle inside from a cold storage site, allow it to warm up at room temperature for at least three hours before using it.
- Do not open the ink bottle package until you are ready to fill the ink tank. The ink bottle is vacuum packed to maintain its reliability. If you leave an ink bottle unpacked for a long time before using it, normal printing may not be possible.
- Once you open an ink bottle, we recommend using it as soon as possible.

Handling precautions for refilling ink

- To ensure you receive premium print quality and to help protect your print head, a variable ink safety reserve remains in the ink tank when your printer indicates to refill ink. The yields quoted for you do not include this reserve.
- For optimum print results, do not maintain low ink levels for extended periods of time.
- Use ink bottles with the correct part code for this printer.
- The ink for this printer must be handled carefully. Ink may splatter when the ink tanks are being filled or refilled with ink. If ink gets on your clothes or belongings, it may not come off.
- Do not squeeze the ink bottles or shake them too vigorously.
- Prolonged use of the printer when the ink level is below the lower line could damage the printer. Fill the ink tank to the upper line while the printer is not operating. To display the correct ink level estimate, reset the ink level after filling the tank.
- To obtain optimum printing results, refill the ink tanks to the upper line at least once every year.

Ink consumption

- ❑ To maintain optimum print head performance, some ink is consumed from all ink tanks during maintenance operations such as print head cleaning. Ink may also be consumed when you turn the printer on.
- ❑ When printing in monochrome or grayscale, color inks instead of black ink may be used depending on the paper type or print quality settings. This is because a mixture of color inks is used to create black.
- ❑ The ink in the ink bottles supplied with your printer is partly used during initial setup. In order to produce high quality printouts, the print head in your printer will be fully charged with ink. This one-off process consumes a quantity of ink and therefore these bottles may print fewer pages compared to subsequent ink bottles.
- ❑ Quoted yields may vary depending on the images that you are printing, the paper type that you are using, the frequency of your prints and environmental conditions such as temperature.
- ❑ Visually check ink levels in the actual ink tanks. Prolonged use of the printer when the ink level is below the lower line could damage the printer. To display the correct ink level estimates, reset the ink level after filling the tank.

Refilling the Ink Tank

1. Select **More** on the home screen.

To select an item, use the ◀▶ buttons, and then press the OK button.

2. Select **Maintenance > Fill Ink**.

3. Select **Fill Ink**.

4. Press the ▼ button to read all the safety and usage precautions for filling ink, and then press the OK button to continue.

5. Close the document cover if it is open.

6. Open the scanner unit with both hand until it locks.

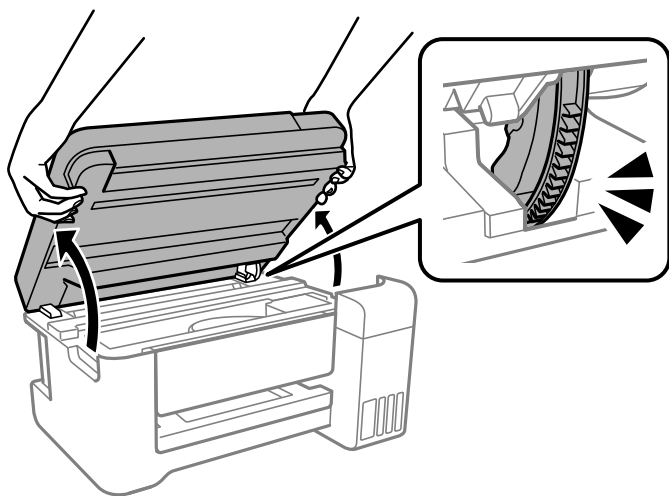

7. Open the ink tank cover.

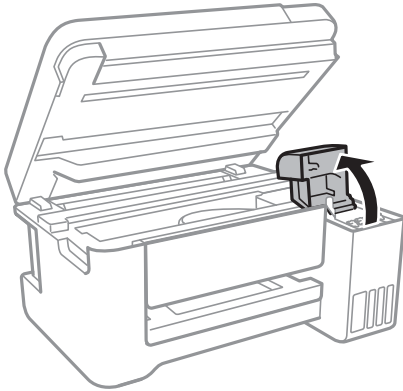

8. Open the cap of the ink tank.

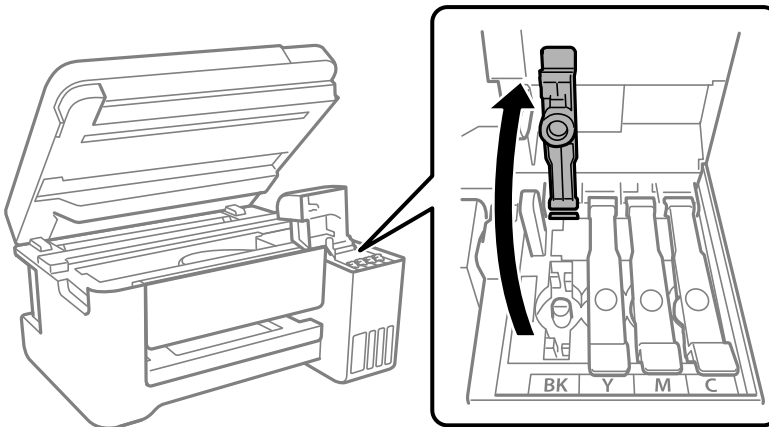

Important:

Make sure that the color of the ink tank matches the ink color that you want to refill.

9. While holding the ink bottle upright, turn the cap slowly to remove it.

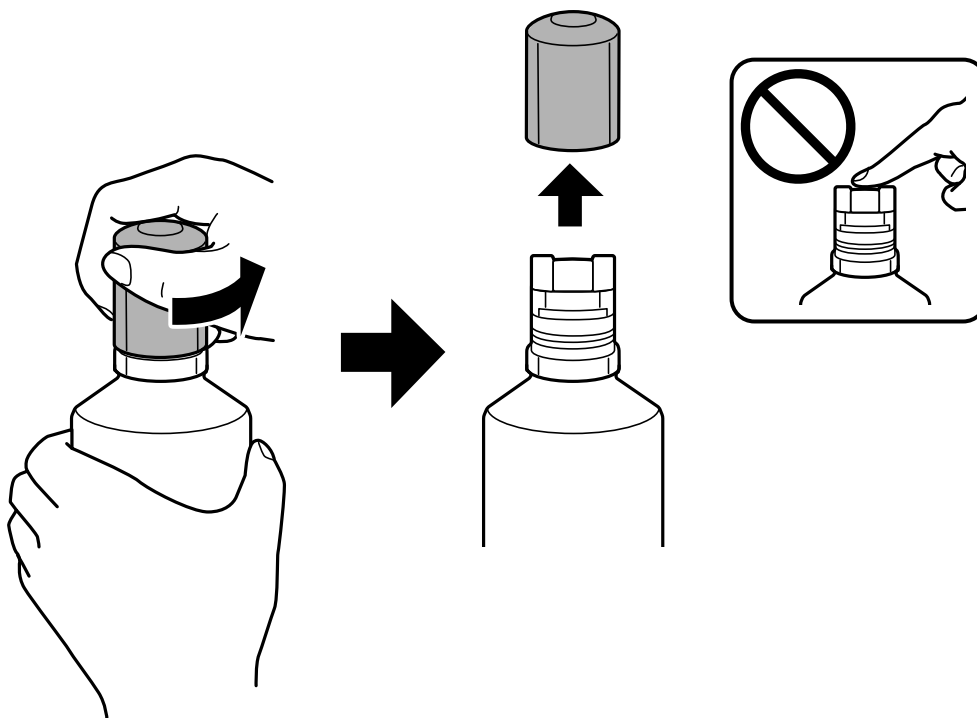

! *Important:*

- Epson recommends the use of genuine Epson ink bottles.*
- Be careful not to spill any ink.*
- Do not touch the top of the ink bottle after removing the cap; otherwise ink may get on your hands.*

10. Check the upper line (a) in the ink tank.

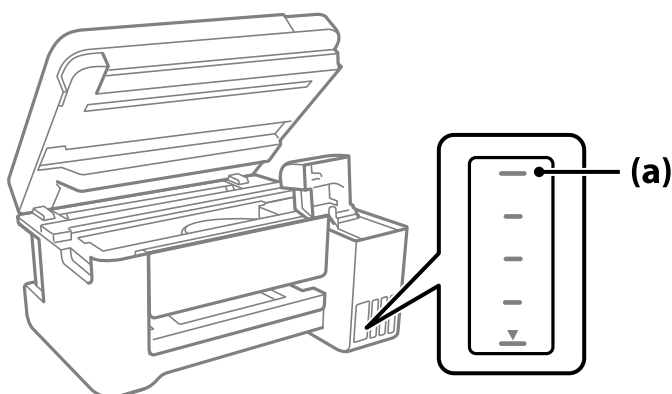

11. Align the top of the ink bottle with the filling port, and then insert it straight into the port to fill ink until it stops automatically at the upper line.

When you insert the ink bottle into the filling port for the correct color, ink starts pouring and the flow stops automatically when the ink reaches the upper line.

If the ink does not start flowing into the tank, remove the ink bottle and reinsert it.

However, do not remove and reinsert the ink bottle when the ink has reached the upper line; otherwise ink may leak or the printer may be damaged if the ink rises above the upper line.

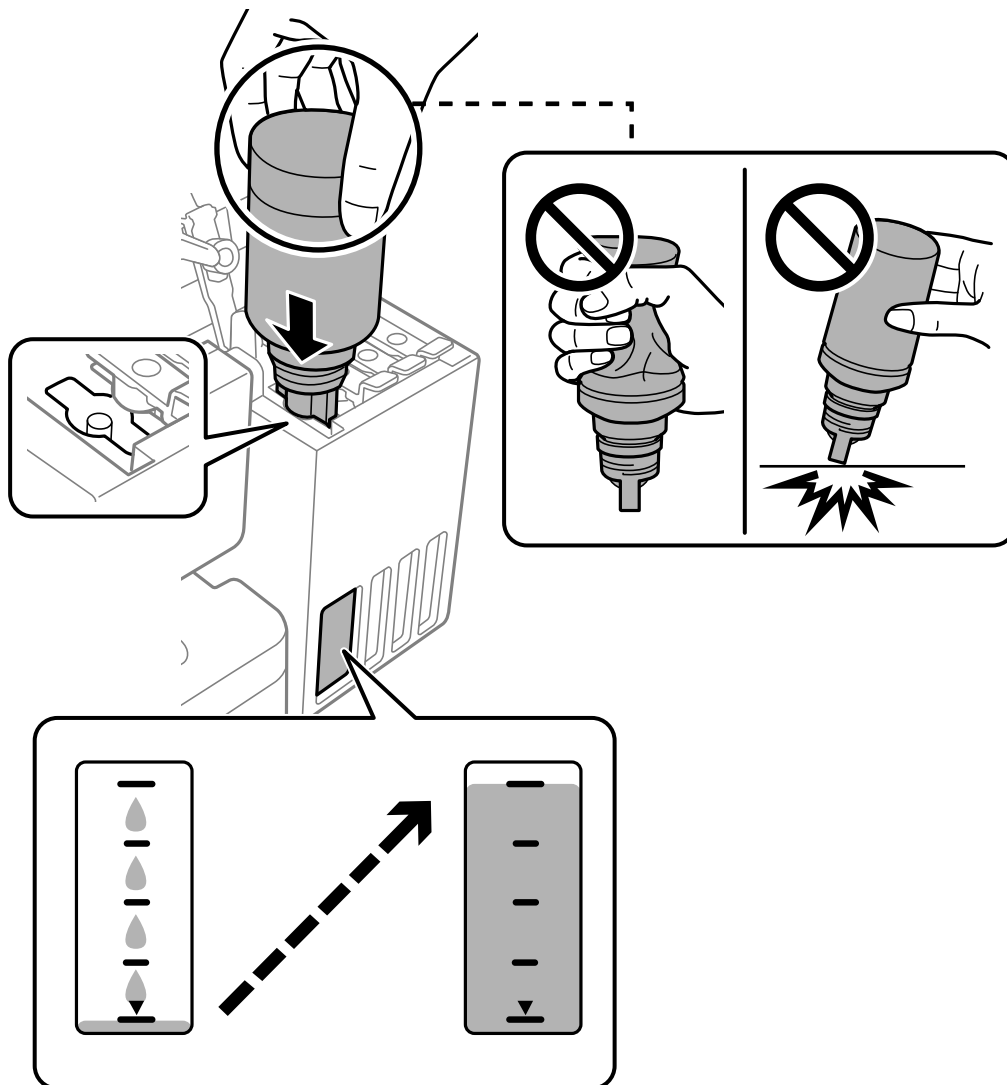

12. When you have finished filling the ink, remove the ink bottle.

! *Important:*

Do not leave the ink bottle inserted; otherwise the bottle may be damaged or ink may leak.

Note:

If any ink remains in the ink bottle, tighten the cap and store the bottle upright for later use.

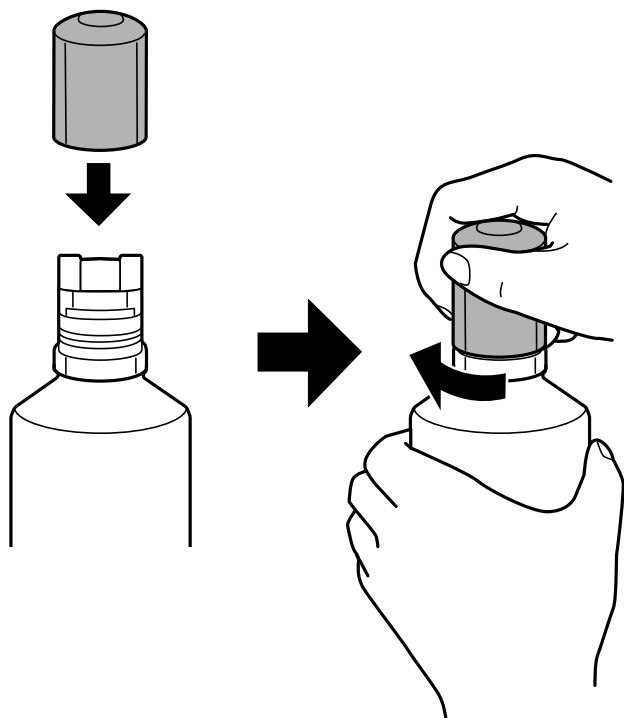

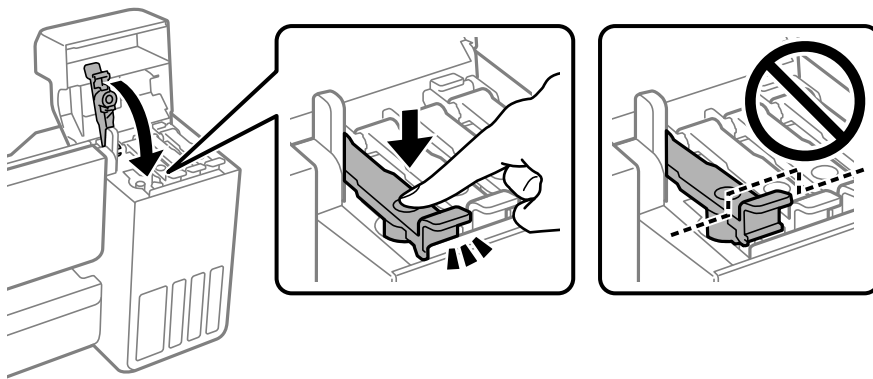

13. Close the ink tank cap securely.

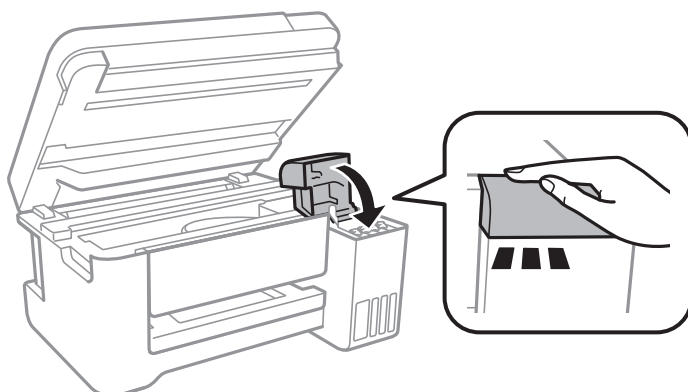

14. Close the ink tank cover firmly.



15. Press the  button, and then follow the on-screen instructions to set the ink level.

 **Important:**

- Even if you do not refill ink up to the upper line on the ink tank, you can continue using the printer. To keep your printer operating at its best, however, fill ink tank up to the upper line and reset the ink level immediately.
- Unless you reset the ink level, the ink level displayed does not change even after refilling the ink.

Related Information

- ➔ [“Ink Bottle Handling Precautions” on page 150](#)
- ➔ [“Ink Bottle Codes” on page 171](#)

Notes on Resetting the Ink Level

Be sure to reset the ink level after refilling the ink.

If you refilled two or more ink tanks, you need to select all of the tanks that you refilled and reset their ink levels.

Unless you reset the ink level, the ink level displayed does not change even after refilling the ink.

Related Information

- ➔ [“Checking the Ink Level” on page 75](#)

It is Time to Replace the Maintenance Box

Maintenance Box Handling Precautions

Read the following instructions before replacing the maintenance box.

- Do not touch the sections shown in the illustration. Doing so may prevent normal operation and you may get smeared with ink.

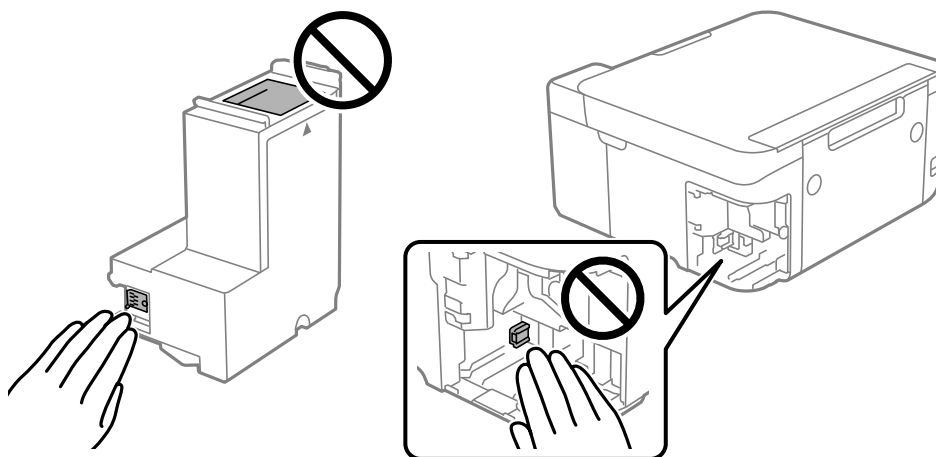

- Do not drop the maintenance box or subject it to strong shocks.
- Do not replace the maintenance box during printing; otherwise, ink may leak.
- Do not remove the maintenance box or its cover except when replacing the maintenance box; otherwise ink may leak.
- When the cover cannot be reattached, the maintenance box may not be installed correctly. Remove the maintenance box, and reinstall it.
- Do not tilt the used maintenance box until after it is sealed in the plastic bag; otherwise ink may leak.
- Do not touch the openings in the maintenance box as you may get smeared with ink.
- Do not reuse a maintenance box which has been removed and left detached for a long period. Ink inside the box will solidify and prevent the box from absorbing any more ink.
- Keep the maintenance box out of direct sunlight.
- Do not store the maintenance box in high or freezing temperatures.

Replacing a Maintenance Box

In some print cycles a very small amount of surplus ink may be collected in the maintenance box. To prevent ink leakage from the maintenance box, the printer is designed to stop printing when the absorbing capacity of the maintenance box has reached its limit. Whether and how often this is required will vary according to the number of pages you print, the type of material that you print and the number of cleaning cycles that the printer performs. Replace the maintenance box when you are prompted to do so. The Epson Status Monitor, your LCD, or lights on the control panel will advise you when this part needs replacing. The need for replacement of the box does not mean that your printer has ceased to operate in accordance with its specifications. The Epson warranty does not cover the cost of this replacement. It is a user-serviceable part.

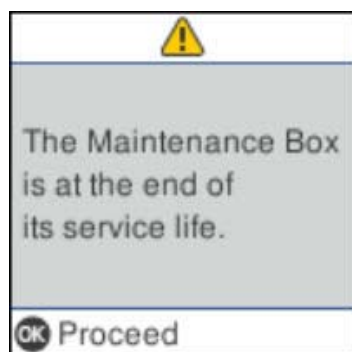

Note:

- ❑ When the maintenance box is full, you cannot print and clean the print head until it is replaced to avoid ink leakage. However, you can perform operations that do not use ink such as scanning.
- ❑ When the following screen is displayed, the part cannot be replaced by users. Contact Epson support. Borderless printing is not available, but printing with a border is available.

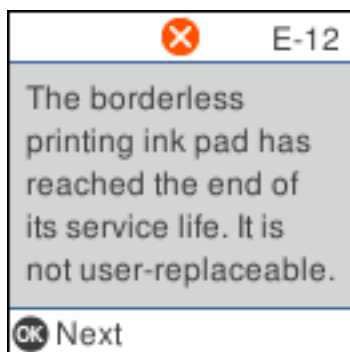

1. Remove the new maintenance box from its package.



Important:

Do not touch the green chip on the side of the maintenance box. Doing so may prevent normal operation and printing.

Note:

A transparent bag for the used maintenance box is provided with the new maintenance box.

2. Loosen the screw with a flat-head screwdriver, and then remove the cover.

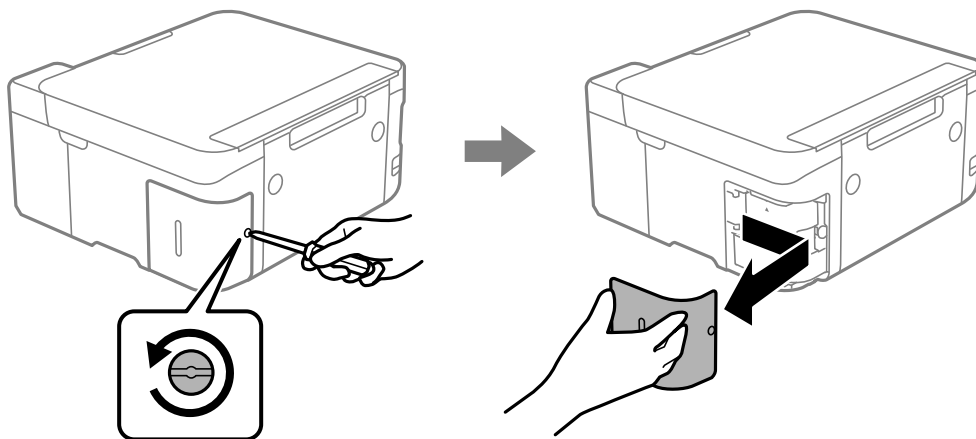

3. Remove the used maintenance box.

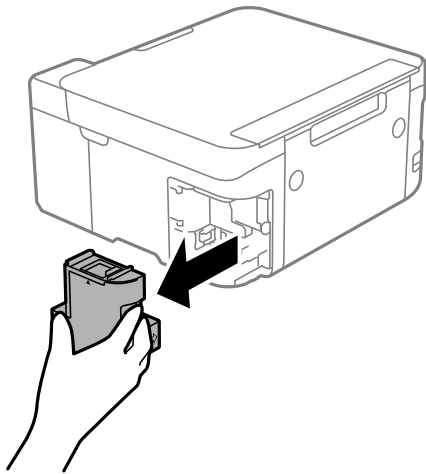

! **Important:**

Do not touch the sections shown in the illustration. Doing so may prevent normal operation and you may get smeared with ink.

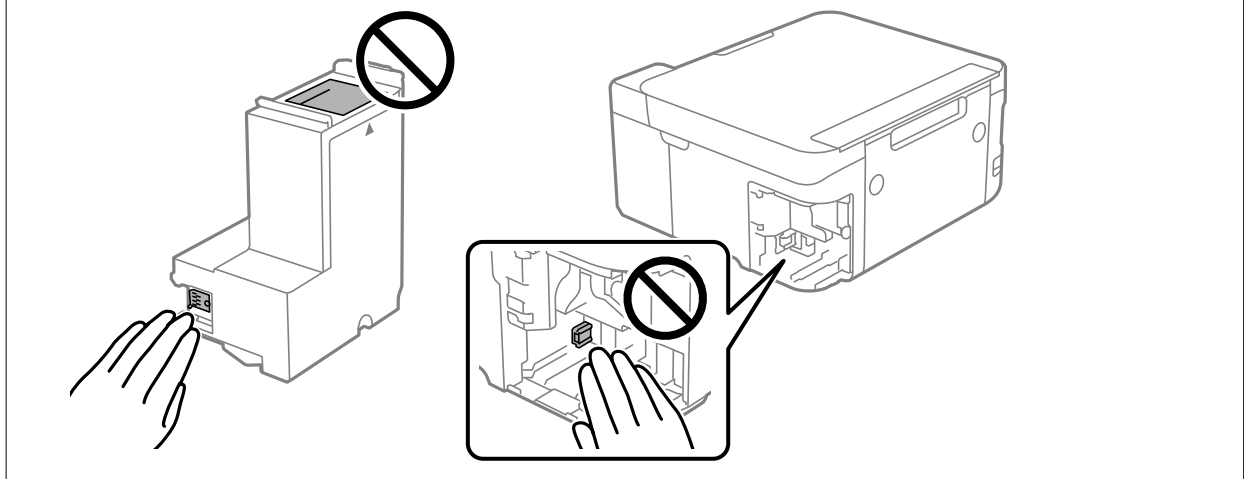

4. Put the used maintenance box in the transparent bag that came with the new maintenance box and seal the bag shut.

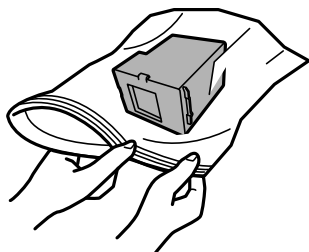

5. Insert the new maintenance box all the way into the printer. Make sure you insert the box in the correct direction.

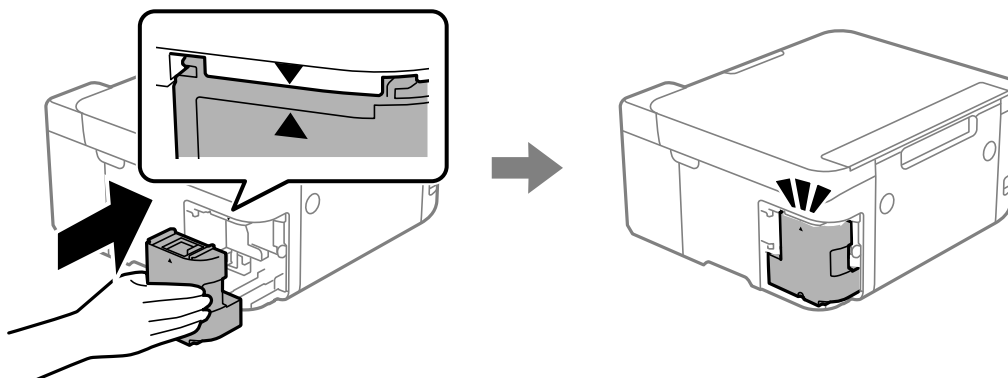

6. Reattach the cover.

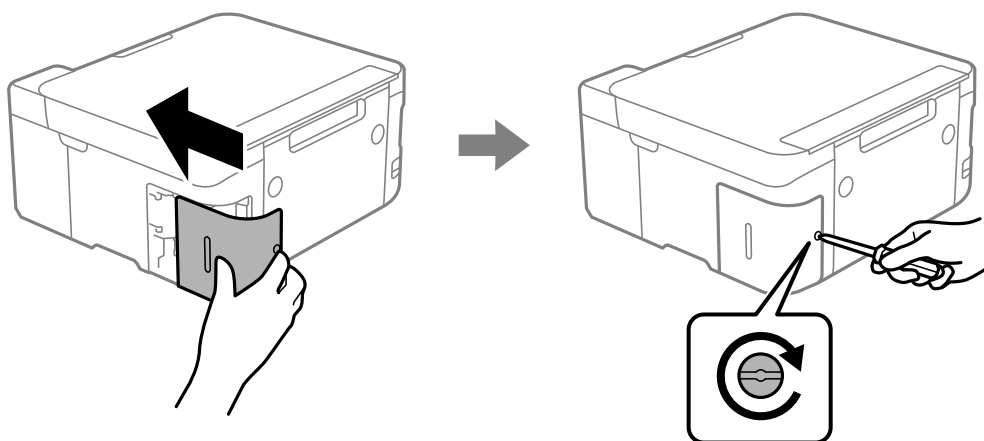

7. Check the message, and then press the OK button.
8. Check the message, and then press the  button.

Related Information

- ➔ [“Maintenance Box Handling Precautions” on page 156](#)
- ➔ [“Maintenance Box Code” on page 172](#)

Cannot Operate the Printer as Expected

The Printer Does Not Turn On or Off

Power Does Not Turn On

One of the following situations may be the cause.

■ **The power cord is not properly plugged into the electrical outlet.**

Solutions

Make sure the power cord is securely plugged in.

■ **The  button was not pressed for long enough.**

Solutions

Hold down the  button for a little longer.

■ **The printer is operating.**

Solutions

Check that the power light is off before you turn on the power.

The Printer Does Not Turn On Automatically

■ **Auto Power On is disabled.**

Solutions



- Select **Settings > Printer Setup**, and then enable the **Auto Power On** Setting.
- When connecting using the USB cable, make sure you connect it securely to the printer and the computer.
- When connecting over a network, make sure the printer's home screen shows that the printer is properly connected to a network.

➔ [“Guide to the Network Icon” on page 23](#)

Power Does Not Turn Off

■ **The  button was not pressed for long enough.**

Solutions

Hold down the  button for a little longer. If you still cannot turn off the printer, unplug the power cord. Then plug the power cord back in and turn the printer back on and off by pressing the  button, in order to avoid drying out the print head.

■ **It may take some time to turn off the power.**

Solutions

When Auto Power On is enabled, it takes longer to turn off the power. See the related information for details.

➔ [“Auto Power On:” on page 176](#)

Power Turns Off Automatically

■ The Power Off Settings or Power Off Timer feature is enabled.

Solutions

- Select **Settings > Printer Setup > Power Off Settings**, and then disable the **Power Off If Inactive** and **Power Off If Disconnected** settings.
- Select **Settings > Printer Setup**, and then disable the **Power Off Timer** Setting.

Note:

Your product may have the **Power Off Settings** or **Power Off Timer** feature depending on the location of purchase.

Operations are Slow

Printing Is Too Slow

One of the following situations may be the cause.

■ Unnecessary applications are running.

Solutions

Close any unnecessary applications on your computer or mobile devices.

■ The print quality setting is too high.

Solutions

Lower the quality setting.

■ Bidirectional printing is disabled.

Solutions

Enable the bidirectional (or high speed) setting. When this setting is enabled, the print head prints while moving in both directions, and the printing speed increases.

- Windows

Select **Bidirectional Printing** on the printer driver's **More Options** tab.

- Mac OS

Select **System Preferences** (or **System Settings**) from the Apple menu > **Printers & Scanners** (or **Print & Scan** or **Print & Fax**), and then select the printer. Click **Options & Supplies > Options** (or **Driver**). Select On as the **Bidirectional Printing** setting.

■ Quiet Mode is enabled.

Solutions

Disable **Quiet Mode**. The printing speed slows down when the printer is running in **Quiet Mode**.

- Control panel

Select **More** on the home screen, select **Quiet Mode**, and then select **Off**.

- Windows

Select **Off** as the **Quiet Mode** setting on the printer driver's **Main** tab.

❑ Mac OS

Select **System Preferences** (or **System Settings**) from the Apple menu > **Printers & Scanners** (or **Print & Scan, Print & Fax**), and then select the printer. Click **Options & Supplies** > **Options** (or **Driver**). Select Off as the **Quiet Mode** setting.

■ **There may be network connection problems with the wireless router.**

Solutions

Reboot the wireless router while taking into consideration other users connected to the network. If this does not solve the problem, place the printer closer to your wireless router or see the documentation provided with the router.

■ **The printer is printing high-density data such as photos on plain paper.**

Solutions

If you are printing high-density data such as photos on plain paper, printing may take some time in order to maintain print quality. This is not a malfunction.

Printing Slows Down Dramatically During Continuous Printing

■ **The printer has slowed down to prevent the printer mechanism from overheating and being damaged.**

Solutions

You can continue printing. To return to normal printing speed, leave the printer idle for at least 30 minutes with the power turned on.

Scanning Speed Is Slow

■ **The scanning resolution setting is too high.**

Solutions

Try scanning at a lower resolution.

LCD Screen Gets Dark

■ **The printer is in sleep mode.**

Solutions

Press any button on the control panel to return the LCD screen to its former state.

The Printer Is Loud

■ **Quiet Mode is disabled.**

Solutions

If operations sounds are too loud, enable **Quiet Mode**. Enabling this feature may reduce printing speed.

Control panel

Select **More** on the home screen, select **Quiet Mode**, and then select **On**.

Windows

Select **On** as the **Quiet Mode** on the printer driver's **Main** tab.

Mac OS

Select **System Preferences** (or **System Settings**) from the Apple menu > **Printers & Scanners** (or **Print & Scan, Print & Fax**), and then select the printer. Click **Options & Supplies** > **Options** (or **Driver**). Select **On** as the **Quiet Mode** setting.

The Root Certificate Needs to be Updated

■ The root certificate has expired.

Solutions

Run Web Config, and then update the root certificate.

➔ [“Application for Configuring Printer Operations \(Web Config\)” on page 174](#)

Cannot Perform Manual 2-sided Printing (Windows)

■ EPSON Status Monitor 3 is disabled.

Solutions

On the printer driver's **Maintenance** tab, click **Extended Settings**, and then select **Enable EPSON Status Monitor 3**.

Manual 2-sided printing may not be available when the printer is accessed over a network or is used as a shared printer.

The Print Settings Menu is Not Displayed (Mac OS)

■ The Epson Printer Driver has Not been Installed Correctly.

Solutions

If the **Print Settings** menu is not displayed on macOS Catalina (10.15) or later, macOS High Sierra (10.13), macOS Sierra (10.12), OS X El Capitan (10.11), OS X Yosemite (10.10), OS X Mavericks (10.9), the Epson printer driver has not been installed correctly. Enable it from the following menu.

Select **System Preferences** (or **System Settings**) from the Apple menu > **Printers & Scanners** (or **Print & Scan** or **Print & Fax**), remove the printer, and then add the printer again.

In macOS Mojave (10.14), you cannot access **Print Settings** in applications made by Apple such as TextEdit.

A Message Prompting You to Reset the Ink Level is Displayed Even After Refilling the Ink

■ The ink level was not reset.

Solutions

Reset the ink level.

➔ [“Reset the Ink Level” on page 75](#)

The Ink Level Display does not Change Even After Refilling the Ink

■ The ink level was not reset.

Solutions

Reset the ink level.

➔ [“Reset the Ink Level” on page 75](#)

Cannot Solve Problem

If you cannot solve the problem after trying all of the solutions, contact Epson support.

If you cannot solve printing or copying problems, see the following related information.

Related Information

- ➔ [“Cannot Solve Printing or Copying Problems” on page 165](#)
- ➔ [“Contacting Epson Support” on page 190](#)

Cannot Solve Printing or Copying Problems

Try the solutions in the order shown, until you solve the problem.

- Make sure you match the paper type loaded in the printer and the paper type selected on the printer to the paper type setting in the printer driver.
[“Paper Size and Type Settings” on page 26](#)
- Use a higher quality setting on the control panel or in the printer driver.
- To check the actual ink remaining, visually check the ink levels in the printer's tanks. Refill the ink tanks if the ink levels are below the lower lines.
- Align the print head.
[“Aligning the Print Head” on page 81](#)

- ❑ Run a nozzle check to see if the print head nozzles are clogged.

If there are missing segments in the nozzle check pattern, the nozzles may be clogged. Run a nozzle check and Cleaning alternately 3 times or Power Cleaning once, and check if the clogging has cleared.

Note that print head cleaning uses some ink.

If there are still missing segments in the nozzle check pattern, turn off the printer and wait for at least 12 hours without printing, and then run a nozzle check. If print quality has still not improved, run Cleaning and a nozzle check again. If it has still not improved, run Power Ink Flushing.

[“Checking and Cleaning the Print Head” on page 77](#)

[“Running Power Cleaning” on page 78](#)

[“Running Power Ink Flushing” on page 79](#)

- ❑ If the problem is clogging, leaving the printer for a while without printing may solve the problem.

You can check the following items while the printer is off.

- ❑ Make sure you are using genuine Epson ink bottles.

Try to use genuine Epson ink bottles. This product is designed to adjust colors based on the use of genuine Epson ink bottles. The use of non-genuine ink bottles may cause print quality to decline.

- ❑ Make sure there are no paper fragments left inside the printer.

When you remove the paper, do not touch the translucent film with your hand or the paper.

- ❑ Make sure the paper is loaded with the printable side facing up and not curled.

[“Paper Handling Precautions” on page 25](#)

[“Available Paper and Capacities” on page 168](#)

[“Unavailable Paper Types” on page 171](#)

If you cannot solve the problem by checking the solutions above, contact Epson support.

Related Information

➔ [“Before Contacting Epson” on page 190](#)

➔ [“Contacting Epson Support” on page 190](#)

Product Information

Paper Information.	168
Consumable Products Information.	171
Software Information.	172
Settings Menu List.	176
Product Specifications.	182
Regulatory Information.	188
Nameplate.	188

Paper Information

Available Paper and Capacities

Genuine Epson Paper

Epson recommends using genuine Epson paper to ensure high-quality printouts.

Do not load more than the maximum number of sheets specified for the paper.

Note:

- The availability of paper varies by location. For the latest information on paper available in your area, contact Epson support.
- See the following for information on available paper types for borderless and 2-sided printing.
 - “Paper for Borderless Printing” on page 170
 - “Paper for 2-Sided Printing” on page 170
- When printing on genuine Epson paper at a user defined size, only **Standard** or **Normal** print quality settings are available. Although some printer drivers allow you to select a better print quality, the printouts are printed using **Standard** or **Normal**.

Paper suitable for printing documents

Media Name	Size	Loading Capacity (Sheets)
Epson Bright White Ink Jet Paper	A4	80

Paper suitable for printing documents and photos

Media Name	Size	Loading Capacity (Sheets)
Epson Photo Quality Ink Jet Paper	A4	80
Epson Double-sided Photo Quality Ink Jet Paper	A4	50
Epson Matte Paper-Heavyweight	A4	20
Epson Double-Sided Matte Paper	A4	1

Paper suitable for printing photos

Media Name	Size	Loading Capacity (Sheets)
Epson Ultra Glossy Photo Paper	A4, 13×18 cm (5×7 in.), 10×15 cm (4×6 in.)	20
Epson Premium Glossy Photo Paper	A4, 13×18 cm (5×7 in.), 10×15 cm (4×6 in.)	20
Epson Premium Semigloss Photo Paper	A4, 10×15 cm (4×6 in.)	20

Media Name	Size	Loading Capacity (Sheets)
Epson Photo Paper Glossy	A4, 13×18 cm (5×7 in.), 10×15 cm (4×6 in.)	20

Various other paper types 

Media Name	Size	Loading Capacity (Sheets)
Epson Photo Quality Self Adhesive Sheets	A4	1

Commercially Available Paper

Do not load more than the maximum number of sheets specified for the paper.

Note:

See the following for information on available paper types for borderless and 2-sided printing.

[“Paper for Borderless Printing” on page 170](#)

[“Paper for 2-Sided Printing” on page 170](#)

Plain papers

Plain paper includes copy paper and letterhead^{*1}.

Size	Loading Capacity (Sheets)
A4, A5, A6, B5, B6, Letter, 16K (195×270 mm)	100
Legal, 8.5×13 in, Indian-Legal	1
User Defined ^{*2*3} (mm) 54×86 to 215.9×1200	1

*1 Paper on which information such as the sender's name or corporation name are pre-printed in the header. There must be a margin of 5 mm or more at the top of the paper. 2-sided printing and borderless printing are not available for letterhead paper.

*2 Copying or printing from the control panel is not available.

*3 Letterhead is not available.

Envelope*

Size	Loading Capacity (Envelopes)
Envelope #10, Envelope DL, Envelope C6	10

* Only the address side is available.

Paper for Borderless Printing

Genuine Epson Paper

- Epson Photo Quality Ink Jet Paper
- Epson Bright White Ink Jet Paper
- Epson Double-sided Photo Quality Ink Jet Paper
- Epson Ultra Glossy Photo Paper
- Epson Premium Glossy Photo Paper
- Epson Premium Semigloss Photo Paper
- Epson Photo Paper Glossy
- Epson Matte Paper-Heavyweight
- Epson Double-Sided Matte Paper
- Epson Photo Quality Self Adhesive Sheets

Related Information

➔ [“Available Paper and Capacities” on page 168](#)

Commercially Available Paper

Plain paper^{*}, copy paper^{*}, letterhead^{*}

* For borderless printing, you can use A4 and Letter sizes.

Related Information

➔ [“Available Paper and Capacities” on page 168](#)

Paper for 2-Sided Printing

Genuine Epson Paper

- Epson Bright White Ink Jet Paper
- Epson Double-sided Photo Quality Ink Jet Paper^{*}
- Epson Double-Sided Matte Paper^{*}

* Manual 2-sided printing only.

Related Information

➔ [“Available Paper and Capacities” on page 168](#)

Commercially Available Paper

- Plain paper^{*1}

Copy paper*¹

Letterhead*²

*1 For A6, A5, B6, Indian-Legal, 8.5×13 in. Legal, and User Defined, you can only use manual 2-sided printing.

*2 Manual 2-sided printing only.

Related Information

➔ [“Available Paper and Capacities” on page 168](#)

Unavailable Paper Types

Do not use the following paper types. Using these types of paper can cause paper feed problems and smears on the printouts.

- Papers that are wavy
- Papers that are torn or cut
- Papers that are folded
- Papers that are damp
- Papers that are too thick or too thin
- Papers that have stickers

Do not use the following envelopes. Using these types of envelope causes paper jams and smears on the printout.

- Envelopes that are curled or folded
- Envelopes with adhesive surfaces on the flaps or window envelopes
- Envelopes that are too thin
They may curl during printing.

Consumable Products Information

Ink Bottle Codes

Epson recommends the use of genuine Epson ink bottles.

The following are the codes for genuine Epson ink bottles.



Important:

- Epson warranty does not cover damage caused by inks other than those specified, including any genuine Epson ink not designed for this printer or any third party ink.*
- Other products not manufactured by Epson may cause damage that is not covered by Epson's warranties, and under certain circumstances, may cause erratic printer behavior.*

Note:

- Ink bottle codes may vary by location. For the correct codes in your area, contact Epson support.
- Although the ink bottles may contain recycled materials, this does not affect printer function or performance.
- Specifications and appearance of the ink bottle are subject to change without prior notice for improvement.

For Asian countries except for Chinese mainland

BK: Black	C: Cyan	M: Magenta	Y: Yellow
001	001	001	001

For Users in Chinese mainland Only

BK: Black	C: Cyan	M: Magenta	Y: Yellow
002	002	002	002

Maintenance Box Code

Epson recommends the use of a genuine Epson maintenance box.

Maintenance box code: T04D1



Important:

Once a maintenance box has been installed in a printer it cannot be used with other printers.

Software Information

This section introduces some of the applications available for your printer. For a list of supported software, see the following Epson website or launch Epson Software Updater for confirmation. You can download the latest applications.

<https://www.epson.com>

Related Information

➔ [“Application for Updating Software and Firmware \(Epson Software Updater\)” on page 175](#)

Application for Printing from a Computer (Windows Printer Driver)

The printer driver controls the printer based on the commands from an application. Selecting settings in the printer driver provides the best printing results. You can also check the status of the printer or keep it in top operating condition using the printer driver utility.

Note:

You can change the language of the printer driver. Select the language you want to use from the **Language** setting on the **Maintenance** tab.

Accessing the printer driver from applications

To select settings that apply only to the application you are using, access the driver from that application.

Select **Print** or **Print Setup** from the **File** menu. Select your printer, and then click **Preferences** or **Properties**.

Note:

Operations differ depending on the application. See the application's help for details.

Accessing the printer driver from the control panel

To select settings that apply to all of the applications, follow the steps below.

Windows 11

Click on the start button, and then select **Settings > Bluetooth & devices > Printers & scanners**. Click your printer, and then select **Printing preferences**.

Windows 10/Windows Server 2022/Windows Server 2019/Windows Server 2016

Click on the start button, and then select **Windows System > Control Panel > View devices and printers in Hardware and Sound**. Right-click on your printer, or press and hold it and then select **Printing preferences**.

Windows 8.1/Windows 8/Windows Server 2012 R2/Windows Server 2012

Select **Desktop > Settings > Control Panel > View devices and printers in Hardware and Sound**. Right-click on your printer, or press and hold it and then select **Printing preferences**.

Windows 7/Windows Server 2008 R2

Click the start button, and select **Control Panel > View devices and printers in Hardware and Sound**. Right-click on your printer and select **Printing preferences**.

Windows Server 2008

Click the start button, and select **Control Panel > Printers in Hardware and Sound**. Right-click on your printer and select **Printing preferences**.

Accessing the printer driver from the printer icon on the task bar

The printer icon on the desktop task bar is a shortcut icon allowing you to quickly access the printer driver.

If you click the printer icon and select **Printer Settings**, you can access the same printer settings window as the one displayed from the control panel. If you double-click this icon, you can check the status of the printer.

Note:

*If the printer icon is not displayed on the task bar, access the printer driver window, click **Monitoring Preferences** on the **Maintenance** tab, and then select **Register the shortcut icon to the taskbar**.*

Starting the utility

Access the printer driver window. Click the **Maintenance** tab.

Application for Printing from a Computer (Mac OS Printer Driver)

The printer driver controls the printer according to the commands from an application. Making settings on the printer driver provides the best printing results. You can also check the status of the printer or keep it in top operating condition using the printer driver utility.

Accessing the printer driver from applications

Click **Page Setup** or **Print** on the **File** menu of your application. If necessary, click **Show Details** (or ▼) to expand the print window.

Note:

Depending on the application being used, **Page Setup** may not be displayed in the **File** menu, and the operations for displaying the print screen may differ. See the application's help for details.

Starting the utility

Select **System Preferences** from the Apple menu > **Printers & Scanners** (or **Print & Scan, Print & Fax**), and then select the printer. Click **Options & Supplies** > **Utility** > **Open Printer Utility**.

Application for Controlling the Scanner (Epson Scan 2)

Epson Scan 2 is a scanner driver that allows you to control the scanner. You can adjust the size, resolution, brightness, contrast, and quality of the scanned image. You can also start this application from a TWAIN-compliant scanning application. See the software help for details on using the features.

Starting on Windows

Note:

For Windows Server operating systems, make sure the **Desktop Experience** feature is installed.

Windows 11

Click the start button, and then select **All apps** > **EPSON** > **Epson Scan 2**.

Windows 10/Windows Server 2022/Windows Server 2019/Windows Server 2016

Click the start button, and then select **EPSON** > **Epson Scan 2**.

Windows 8.1/Windows 8/Windows Server 2012 R2/Windows Server 2012

Enter the application name in the search charm, and then select the displayed icon.

Windows 7/Windows Server 2008 R2/Windows Server 2008

Click the start button, and then select **All Programs** > **EPSON** > **Epson Scan 2**.

Starting on Mac OS

Select **Go** > **Applications** > **Epson Software** > **Epson Scan 2**.

Application for Configuring Printer Operations (Web Config)

Web Config is an application that runs in a web browser, such as Microsoft Edge and Safari, on a computer or mobile device. You can confirm the printer status or change the network service and printer settings. To use Web Config, connect the printer and the computer or device to the same network.

The following browsers are supported. Use the latest version.

Microsoft Edge, Firefox, Chrome, Safari

Note:

You may be asked to enter the administrator password while using Web Config. See the related information below for more details.

Related Information

➔ [“Default Value of the Administrator Password” on page 15](#)

Running Web Config on a Web Browser

1. Check the printer's IP address.

Select **Settings > Network Settings > Connection Check** from the control panel to start the connection check.

Press the  button or the OK button to print the network connection report. Check the printer's IP address on the printed network connection report.

2. Launch a Web browser from a computer or mobile device, and then enter the printer's IP address.

Format:

IPv4: http://the printer's IP address/

IPv6: http://[the printer's IP address]/

Examples:

IPv4: http://192.168.100.201/

IPv6: http://[2001:db8::1000:1]/

Note:

Using the mobile device, you can also run Web Config from the product information screen of the Epson Smart Panel.

Since the printer uses a self-signed certificate when accessing HTTPS, a warning is displayed on the browser when you start Web Config; this does not indicate a problem and can be safely ignored.

Application for Updating Software and Firmware (Epson Software Updater)

Epson Software Updater is an application that installs new software, and updates firmware over the Internet. If you want to check for update information regularly, you can set the interval for checking for updates in Epson Software Updater's Auto Update Settings.

Note:

Windows Server operating systems are not supported.

Starting on Windows

- Windows 11

Click the start button, and then select **All apps > EPSON Software > Epson Software Updater**.

- Windows 10

Click the start button, and then select **EPSON Software > Epson Software Updater**.

- Windows 8.1/Windows 8

Enter the application name in the search charm, and then select the displayed icon.

- Windows 7

Click the start button, and then select **All Programs > EPSON Software > Epson Software Updater**.

Note:

*You can also start Epson Software Updater by clicking the printer icon on the task bar on the desktop, and then selecting **Software Update**.*

Starting on Mac OS

Select **Go > Applications > Epson Software > Epson Software Updater**.

Related Information

➔ [“Installing the Applications Separately” on page 88](#)

Settings Menu List

Select **More** > **Settings** on the home screen of the printer to make various settings.

Feature names and setting menu items may change depending on the firmware version.

Printer Setup

More > Settings > Printer Setup

Paper Source Settings:

Paper Setting:

Select the paper size and paper type you loaded in the paper source.

A4/Letter Auto Switching:

Select **On** to feed paper from the paper source set as A4 size when there is no paper source set as Letter, or feed from the paper source set as Letter size when there is no paper source set as A4.

Error Notice:

Paper Size Notice:

Select **On** to display an error message when the selected paper size does not match the loaded paper.

Paper Type Notice:

Select **On** to display an error message when the selected paper type does not match the loaded paper.

Paper Setup Auto Display:

Select **On** to display the **Paper Setting** screen when loading paper in the paper source. If you disable this feature, you cannot print from an iPhone, iPad, or iPod touch using AirPrint.

Quiet Mode:

Select **On** to reduce noise during printing, depending on the selected paper type and quality. Enabling this setting may reduce print speed.

Auto Power On:

Select **On** to turn on the printer automatically when it receives a print or scan job over a USB-connection or a network connection. If the output tray is stored, slide it out manually to start printing.

Enabling **Auto Power On** increases power consumption slightly in standby status when compared to turning the printer off completely. Also, it takes longer to turn off the power. Leave the power cord

plugged in when using this feature. If you unplug the power cord, make sure the power light is turned off.

Use the **Power Off Timer** setting if you want the printer to automatically turn off when the print or scan job is finished and a set time period has passed with no operations performed. This is useful when printing from a remote location such as over the Internet.

Power Off Settings:

Your product may have this feature or the **Power Off Timer** feature depending on the location of purchase.

Power Off If Inactive:

Select this setting to turn the printer off automatically if it is not used for a specified period of time. You can adjust the time before power management is applied. Any increase will affect the product's energy efficiency. Please consider the environment before making any change.

Power Off If Disconnected:

Select this setting to turn the printer off after a specified period of time when all ports including the USB port are disconnected. This feature may not be available depending on your region.

For users in Europe, see the following website for the specified period of time.

<https://www.epson.eu/energy-consumption>

For Middle East, Turkey, Africa, Central and West Asia users, see the following Website for details on power consumption.

<https://www.epson.com/eme>

Power Off Timer:

Your product may have this feature or the **Power Off Settings** feature depending on the location of purchase.

Select this setting to turn the printer off automatically when it is not used for a specified period of time. You can adjust the time before power management is applied. Any increase will affect the product's energy efficiency. Please consider the environment before making any change.

Language:

Select the language used on the LCD screen.

Keyboard:

Change the layout of the keyboard on the LCD screen.

Sleep Timer:

Specify how long the printer waits to enter sleep mode (energy saving mode) if it has not been used. The LCD screen turns black during sleep mode.

Auto Error Solver:

Select an action to perform when a 2-sided printing error or a memory full error occurs.

On

Displays a warning and prints in single-sided mode when a 2-sided printing error occurs, or prints only what the printer could process when a memory full error occurs.

Off

Displays an error message and cancels printing.

Ink Drying Time:

Select the ink drying time you want to use when performing 2-sided printing. The printer prints on the second side of the paper after the specified time has elapsed. If your printout is smeared, increase the time.

PC Connection via USB:

Select **Enable** to allow a computer to access the printer when connected by USB. When **Disable** is selected, printing and scanning that is not sent over a network connection is restricted.

Related Information

➔ [“Saving Power” on page 87](#)

Network Settings

Select the menus on the control panel as described below.

More > Settings > Network Settings

Print Status Sheet:

Prints a network status sheet.

Information about Wi-Fi, Wi-Fi Direct, and other network parameters is printed on two or more pages.

Connection Settings:

Connect the printer to the network over a wireless LAN. Select your connection method and follow the on-screen instructions.

Wi-Fi:

Wi-Fi Setup Wizard:

Configures Wi-Fi settings by having you enter the SSID and password.

Push Button Setup (WPS):

Configures Wi-Fi settings via Push Button Setup (WPS).

Others:

PIN Code (WPS):

Configures Wi-Fi settings via PIN Code (WPS).

Disable Wi-Fi:

Disconnects the connection to the Wi-Fi router.

Wi-Fi Direct:

Modify:

Change Network Name:

Changes the Wi-Fi Direct SSID (network name).

Change Password:

Changes the password for the Wi-Fi Direct connection.

Change Frequency Range:

Select the frequency band for Wi-Fi Direct connection. Changing the frequency disconnects the connected device.

The availability of these channels and use of the product outdoors over these channels varies by location.

<https://support.epson.net/wifi5ghz/>

Disable Wi-Fi Direct:

Disables the Wi-Fi Direct function.

Restore Default Settings:

Resets the Wi-Fi Direct settings.

Other Methods:

iOS:

Displays a QR code to connect a mobile device using Wi-Fi Direct.

Android:

Displays a QR code to connect a mobile device using Wi-Fi Direct.

Other OS Devices:

Displays the SSID and password to connect using Wi-Fi Direct.

Easy Connect with App:

Establish a wireless LAN connection using the wireless LAN information for your computer or mobile device.

Connection Check:

Checks the current network connection and prints a report. If there are any problems with the connection, see the report for solutions.

Related Information

- ➔ [“Configuring Wi-Fi Settings from the Control Panel” on page 93](#)
- ➔ [“Connecting a Device and Printer Directly \(Wi-Fi Direct\)” on page 103](#)

Epson Connect Services

Select the menus on the control panel as described below.

More > Settings > Epson Connect Services

Register/Delete:

Register or delete the printer to or from the Epson Connect services.

For usage guides, see the following portal website.

<https://epson.com/connect> (U.S.)

<https://epson.ca/connect> (Canada)

<https://latin.epson.com/connect> (Latin America)

<http://www.epsonconnect.eu> (Europe only)

<https://www.epsonconnect.ae> (Middle East, Türkiye, Africa, Central and West Asia only)

<https://www.epsonconnect.com/> (Other regions)

Suspend/Resume:

Select to suspend or resume Epson Connect services.

Email Address:

Check the printer's email address that is registered to the Epson Connect services.

Status:

Check whether or not the printer is registered and connected to the Epson Connect services.

Print Status Sheet

Select the menus on the control panel as described below.

More > Settings > Print Status Sheet

Configuration Status Sheet:

Print information sheets showing the current printer status and settings.

Supply Status Sheet:

Print information sheets showing the status of consumables.

Usage History Sheet:

Print information sheets showing the usage history of the printer.

Print Counter

Select the menus on the control panel as described below.

More > Settings > Print Counter

Displays the total number of prints, B&W prints, and color prints including items such as the status sheet from the time you purchased the printer. If you select **Print Sheet**, the Usage History Sheet is printed.

You can also check the number of pages printed from other functions on the Usage History Sheet.

Customer Research

Select the menus on the control panel as described below.

More > Settings > Customer Research

If you agree to provide customer usage information, product usage information such as the number of prints will be provided to Seiko Epson Corporation. The information collected is used to improve our products and services.

Previous Settings:

Displays the approval status.

Restore Default Settings

Select the menus on the control panel as described below.

More > Settings > Restore Default Settings

Network Settings:

Resets the network settings to their defaults.

Copy Settings:

Resets the copy settings to their defaults.

Scan Settings:

Resets the scan settings to their defaults.

Clear All Data and Settings:

Clears all the personal information stored in the printer's memory and resets all settings to their defaults.

Firmware Update

Select the menus on the control panel as described below.

More > Settings > Firmware Update

Update:

Check if a later version of the firmware has been uploaded to the network server. If an update is available, you can select whether or not to start updating.

Current Version:

Displays the current firmware version of your printer.

Notification:

Select **On** to receive a notification if a firmware update is available.

Product Specifications

Printer Specifications

Print Head Nozzle Placement		Black ink nozzles: 180×1 rows Color ink nozzles: 59×3 rows for each color
Weight of Paper*	Plain Paper	0.08 to 0.11 mm (64 to 90 g/m ²)
	Envelopes	75 to 100 g/m ²

* Even when the paper thickness is within this range, the paper may not feed in the printer or the print quality may decline depending on the paper properties or quality.

Printable Area

Printable Area for Single Sheets

Print quality may decline in the shaded areas due to the printer's mechanism.

Printing with borders

	A	3.0 mm (0.12 in.)
	B	3.0 mm (0.12 in.)
	C	41.0 mm (1.61 in.)
	D	37.0 mm (1.46 in.)

*Direction of paper being fed.

Borderless printing

	A	44.0 mm (1.73 in.)
	B	40.0 mm (1.57 in.)

*Direction of paper being fed.

Printable Area for Envelopes

Print quality may decline in the shaded areas due to the printer's mechanism.

	A	3.0 mm (0.12 in.)
	B	3.0 mm (0.12 in.)
	C	18.0 mm (0.71 in.)
	D	41.0 mm (1.61 in.)

*Direction of paper being fed.

Scanner Specifications

Scanner Type	Flatbed
Photoelectric Device	CIS
Effective Pixels	10200×14040 pixels (1200 dpi)
Maximum Document Size	216×297 mm (8.5×11.7 in.) A4, Letter
Scanning Resolution	1200 dpi (main scan) 2400 dpi (sub scan)
Output Resolution	50 to 9600 dpi in 1 dpi increments
Color Depth	Color <input type="checkbox"/> 48 bits per pixel internal (16 bits per pixel per color internal) <input type="checkbox"/> 24 bits per pixel external (8 bits per pixel per color external) Grayscale <input type="checkbox"/> 16 bits per pixel internal <input type="checkbox"/> 8 bits per pixel external
Light Source	LED

Interface Specifications

For Computer	Hi-Speed USB*
--------------	---------------

* USB 3.0 cables are not supported.

Network Specifications

Wi-Fi Specifications

Standards	IEEE802.11b/g/n*1
Frequency Range	2.4 GHz
Connection Modes	Infrastructure, Wi-Fi Direct (Simple AP)*2*3
Wireless Securities*4	WEP (64/128bit), WPA2-PSK (AES)*5, WPA3-SAE (AES)

*1 IEEE802.11n is only available for the HT20.

*2 Not supported for IEEE 802.11b.

*3 Simple AP mode is compatible with a Wi-Fi connection (infrastructure).

*4 Wi-Fi Direct supports WPA2-PSK (AES) only.

*5 Complies with WPA2 standards with support for WPA/WPA2 Personal.

Network Functions and IPv4/IPv6

Functions			Supported	Remarks
Network Printing	EpsonNet Print (Windows)	IPv4	✓	-
	Standard TCP/IP (Windows)	IPv4, IPv6	✓	-
	WSD Printing (Windows)	IPv4, IPv6	✓	-
	Bonjour Printing (Mac OS)	IPv4, IPv6	✓	-
	IPP Printing (Windows, Mac OS)	IPv4, IPv6	✓	-
	Epson Connect (Email Print, Remote Print)	IPv4	✓	-
	AirPrint (iOS, Mac OS)	IPv4, IPv6	✓	iOS 5 or later, OS X Mavericks (10.9.5) or later*
	Mopria Print	IPv4, IPv6	✓	-
	Chromebook Print (ChromeOS)	IPv4, IPv6	✓	-
	Microsoft IPP Class Driver (Windows)	IPv4, IPv6	✓	-

Functions			Supported	Remarks
Network Scanning	Epson Scan 2	IPv4, IPv6	✓	-
	Epson ScanSmart	IPv4	✓	Windows 7 or later, or OS X El Capitan (10.11) or later
	Epson Event Manager (Mac OS)	IPv4	✓	OS X Yosemite (10.10)/OS X Mavericks (10.9.5)
	Epson Connect (Scan to Cloud)	IPv4	-	-
	AirPrint (Scan)	IPv4, IPv6	✓	OS X Mavericks (10.9.5) or later*
	Mopria Scan	IPv4, IPv6	✓	-
	Chromebook Scan (ChromeOS)	IPv4, IPv6	✓	-
Fax	Send a fax	IPv4	-	-
	Receive a fax	IPv4	-	-
	AirPrint (Faxout)	IPv4, IPv6	-	-

* We recommend using the latest version of iOS or Mac OS.

Security Protocol

SSL/TLS	HTTPS Server/Client, IPPS
TLS Version	1.3, 1.2, 1.1*, 1.0*
SNMP (Simple Network Management Protocol)	SNMPv3

* Disabled by default.

Supported Third Party Services

Services		Supported	Remarks
AirPrint	Print	✓	iOS 5 or later/OS X Mavericks (10.9.5) or later* ¹
	Scan	✓	OS X Mavericks (10.9.5) or later* ¹
	Fax	-	-

Services		Supported	Remarks
Mopria	Print	✓	Android 8.0 or later, Windows 10 or later ^{*2}
	Scan	✓	Android 12.0 or later, Windows 10 or later ^{*2} , ChromeOS 89 or later ^{*3}
Chromebook	Print	✓	ChromeOS 89 or later ^{*3}
	Scan	✓	ChromeOS 89 or later ^{*3}

*1 We recommend using the latest version of iOS or Mac OS.

*2 We recommend using the latest version of Windows.

*3 We recommend using the latest version of ChromeOS.

Dimensions

Dimensions	<p>Storage</p> <ul style="list-style-type: none"> <input type="checkbox"/> Width: 375 mm (14.8 in.) <input type="checkbox"/> Depth: 347 mm (13.7 in.) <input type="checkbox"/> Height: 187 mm (7.4 in.) <p>Printing</p> <ul style="list-style-type: none"> <input type="checkbox"/> Width: 375 mm (14.8 in.) <input type="checkbox"/> Depth: 589 mm (23.2 in.) <input type="checkbox"/> Height: 286 mm (11.3 in.)
Weight*	Approx. 5.4 kg (11.9 lb)

* Without the ink and the power cord.

Electrical Specifications

Power Supply Rating	AC 220-240 V
Rated Frequency Range	50-60 Hz
Rated Current	0.2 A
Power Consumption (with USB Connection)	<p>Standalone copying: Approx. 12.0 W (ISO/IEC24712)</p> <p>Ready mode: Approx. 5.6 W</p> <p>Sleep mode: Approx. 0.5 W*</p> <p>Power off: Approx. 0.1 W</p>

* This is a reference value. Actual power consumption may vary depending on your environment.

Note:

- Check the label on the printer for its voltage.
- For European users, see the following Website for details on power consumption.

<https://www.epson.eu/energy-consumption>

Environmental Specifications

Operation	<p>Use the printer within the temperature (°C) and humidity (%) ranges shown in the graph, and in an environment without condensation.</p>
Storage	<p>Temperature: -20 to 40°C (-4 to 104°F)*</p> <p>Humidity: 5 to 85% RH (without condensation)</p>

* You can store the printer for one month at 40°C (104°F).

Environmental Specifications for Ink Bottles

Storage Temperature	-20 to 40 °C (-4 to 104 °F)*
Freezing Temperature	-15 °C (5 °F)
	Ink thaws and is usable after approximately 2 hours at 25 °C (77 °F).

* You can store ink bottles for one month at 40 °C (104 °F).

System Requirements

- Windows
 - Windows 7, Windows 8/8.1, Windows 10, Windows 11 or later
 - Windows Server 2008 or later
- Mac OS
 - Mac OS X 10.9.5 or later, macOS 11 or later
- Chrome OS

Note:

Only supports the standard OS features.

Regulatory Information

Standards and Approvals for Mongolian Model

This product contains the following approved part, which is certified by the Communications Regulatory Commission of Mongolia.

11n+BT combo module: J26H006 (certificate No. A23001080)

Restrictions on Copying

Observe the following restrictions to ensure the responsible and legal use of the printer.

Copying of the following items is prohibited by law:

- Bank bills, coins, government-issued marketable securities, government bond securities, and municipal securities
- Unused postage stamps, pre-stamped postcards, and other official postal items bearing valid postage
- Government-issued revenue stamps, and securities issued according to legal procedure

Exercise caution when copying the following items:

- Private marketable securities (stock certificates, negotiable notes, checks, etc.), monthly passes, concession tickets, etc.
- Passports, driver's licenses, warrants of fitness, road passes, food stamps, tickets, etc.

Note:

Copying these items may also be prohibited by law.

Responsible use of copyrighted materials:

Printers can be misused by improperly copying copyrighted materials. Unless acting on the advice of a knowledgeable attorney, be responsible and respectful by obtaining the permission of the copyright holder before copying published material.

Nameplate

The nameplate is located on the bottom of the product.



Where to Get Help

Technical Support Web Site.	190
Contacting Epson Support.	190

Technical Support Web Site

If you need further help, visit the Epson support website shown below. Select your country or region and go to the support section of your local Epson website. The latest drivers, FAQs, manuals, or other downloadables are also available from the site.

<https://support.epson.net/>

<https://support.epson.com> (U.S., Canada, and Latin America)

<https://www.epson.eu/support> (Europe)

If your Epson product is not operating properly and you cannot solve the problem, contact Epson support.

Contacting Epson Support

Before Contacting Epson

If your Epson product is not operating properly and you cannot solve the problem using the troubleshooting information in your product manuals, contact Epson support services for assistance.

The following Epson support list is based on the country of sale. Some products may not be sold in your current location, so be sure to contact Epson support for the area in which you purchased your product.

If Epson support for your area is not listed below, contact the dealer where you purchased your product.

Epson support will be able to help you much more quickly if you give them the following information:

- Product serial number

(The label attachment position depends on the product; it may be on the back, the open side of the cover, or the bottom.)

- Product model

- Product software version

(Click **About**, **Version Info**, or a similar button in the product software.)

- Brand and model of your computer

- Your computer operating system name and version

- Names and versions of the software applications you normally use with your product

Note:

Depending on the product, network settings may be stored in the product's memory. Due to breakdown or repair of a product, settings may be lost. Epson shall not be responsible for the loss of any data, for backing up or recovering settings even during a warranty period. We recommend that you make your own backup data or take notes.

Help for Users in the U.S. and Canada

If you need to contact Epson for technical support services, use the following support options.

Internet Support

Visit Epson's support website at <https://support.epson.com> and select your product for solutions to common problems. You can download drivers and documentation, get FAQs and troubleshooting advice, or e-mail Epson with your questions.

Speak to a Support Representative

Before you call Epson for support, please have the following information ready:

- Product name
- Product serial number (located on a label on the product)
- Proof of purchase (such as a store receipt) and date of purchase
- Computer configuration
- Description of the problem

Then call:

- Canada: (905) 709-3839, 7 a.m. to 4 p.m., Pacific Time, Monday through Friday

Days and hours of support are subject to change without notice. Toll or long distance charges may apply.

Purchase Supplies and Accessories

You can purchase genuine Epson ink and paper at <https://epson.com> (U.S. sales) or <https://epson.ca> (Canadian sales). You can also purchase supplies from an Epson authorized reseller. To find the nearest one, call 800-GO-EPSON (800-463-7766) in the U.S. or 800-807-7766 in Canada.

Help for Users in Latin America

If you need to contact Epson for technical support services, use the following support options.

Internet Support

Visit <https://support.epson.com> and select your product for solutions to common problems. You can download drivers and documentation, get troubleshooting advice, or e-mail Epson with your questions.

Speak to a Support Representative

Before you call Epson for support, please have the following information ready:

- Product name
- Product serial number (located on a label on the product)
- Proof of purchase (such as a store receipt) and date of purchase
- Computer configuration
- Description of the problem

Then call:

Country	Telephone
Argentina	0800-288-37766

Country	Telephone
Bolivia*	800-100-116
Brazil	State capitals and metropolitan areas: 3004-6627 Other areas: 0800-377-6627 / 0800-EPSONBR
Chile	(56 2) 2484-3400
Colombia	Bogota: 601 602 4751 Other cities: 01-8000-915235
Costa Rica	800-377-6627
Dominican Republic*	1-888-760-0068
Ecuador*	1-800-000-044
El Salvador*	800-6570
Guatemala*	1-800-835-0358
Mexico	Mexico City: (52 55) 1323-2052 Other cities: 800-087-1080
Nicaragua*	00-1-800-226-0368
Panama*	00-800-052-1376
Paraguay	009-800-521-0019
Peru	Lima: (51 1) 418-0210 Other cities: 0800-10126
Uruguay	00040-5210067

* Contact your local phone company to call this toll-free number from a mobile phone.

If your country does not appear in the list, contact the sales office in the nearest country. Toll or long distance charges may apply.

Purchase Supplies and Accessories

You can purchase genuine Epson ink, paper, and accessories from an Epson authorized reseller. To find the nearest reseller, visit <https://latin.epson.com> or call your nearest Epson sales office.

Help for Users in Europe

Check your Pan-European Warranty Document for information on how to contact Epson support.

Help For Users in Middle East, Turkey, Africa, Central and West Asia

Please refer to <https://www.epson.com/eme> for information on how to contact Epson support.

Help for Users in Taiwan

Contacts for information, support, and services are:

World Wide Web

<http://www.epson.com.tw>

Information on product specifications, drivers for download, and products enquiry are available.

Epson HelpDesk

Phone: +886-2-2165-3138

Our HelpDesk team can help you with the following over the phone:

- Sales enquiries and product information
- Product usage questions or problems
- Enquiries on repair service and warranty

Repair service center:

<http://www.tekcare.com.tw/branchMap.page>

TekCare corporation is an authorized service center for Epson Taiwan Technology & Trading Ltd.

Help for Users in Australia

Epson Australia wishes to provide you with a high level of customer service. In addition to your product manuals, we provide the following sources for obtaining information:

Internet URL

<http://www.epson.com.au>

Access the Epson Australia World Wide Web pages. Worth taking your modem here for the occasional surf! The site provides a download area for drivers, Epson contact points, new product information and technical support (e-mail).

Epson Helpdesk

Phone: 1300-361-054

Epson Helpdesk is provided as a final backup to make sure our clients have access to advice. Operators on the Helpdesk can aid you in installing, configuring and operating your Epson product. Our Pre-sales Helpdesk staff can provide literature on new Epson products and advise where the nearest dealer or service agent is located. Many types of queries are answered here.

We encourage you to have all the relevant information on hand when you ring. The more information you prepare, the faster we can help solve the problem. This information includes your Epson product manuals, type of computer, operating system, application programs, and any information you feel is required.

Transportation of Product

Epson recommends retaining product packaging for future transportation. Securing the ink tank with tape and keeping the product upright is also recommended.

Help for Users in New Zealand

Epson New Zealand wishes to provide you with a high level of customer service. In addition to your product documentation, we provide the following sources for obtaining information:

Internet URL

<http://www.epson.co.nz>

Access the Epson New Zealand World Wide Web pages. Worth taking your modem here for the occasional surf! The site provides a download area for drivers, Epson contact points, new product information and technical support (e-mail).

Epson Helpdesk

Phone: 0800 237 766

Epson Helpdesk is provided as a final backup to make sure our clients have access to advice. Operators on the Helpdesk can aid you in installing, configuring and operating your Epson product. Our Pre-sales Helpdesk staff can provide literature on new Epson products and advise where the nearest dealer or service agent is located. Many types of queries are answered here.

We encourage you to have all the relevant information on hand when you ring. The more information you prepare, the faster we can help solve the problem. This information includes your Epson product documentation, type of computer, operating system, application programs, and any information you feel is required.

Transportation of Product

Epson recommends retaining product packaging for future transportation. Securing the ink tank with tape and keeping the product upright is also recommended.

Help for Users in Singapore

Sources of information, support, and services available from Epson Singapore are:

World Wide Web

<http://www.epson.com.sg>

Information on product specifications, drivers for download, Frequently Asked Questions (FAQ), Sales Enquiries, and Technical Support via e-mail are available.

Epson HelpDesk

Toll Free: 800-120-5564

Our HelpDesk team can help you with the following over the phone:

- Sales enquiries and product information
- Product usage questions or problem troubleshooting
- Enquiries on repair service and warranty

Help for Users in Thailand

Contacts for information, support, and services are:

World Wide Web

<http://www.epson.co.th>

Information on product specifications, drivers for download, Frequently Asked Questions (FAQ), and e-mail are available.

Epson Call Centre

Phone: 66-2460-9699

Email: support@eth.epson.co.th

Our Call Centre team can help you with the following over the phone:

- Sales enquiries and product information
- Product usage questions or problems
- Enquiries on repair service and warranty

Help for Users in Vietnam

Contacts for information, support, and services are:

Epson Service Center

27 Yen Lang, Trung Liet Ward, Dong Da District, Ha Noi City. Tel: +84 24 7300 0911

38 Le Dinh Ly, Thac Gian Ward, Thanh Khe District, Da Nang. Tel: +84 23 6356 2666

194/3 Nguyen Trong Tuyen, Ward 8, Phu Nhuan Dist., HCMC. Tel: +84 28 7300 0911

31 Phan Boi Chau, Ward 14, Binh Thanh District, HCMC. Tel: +84 28 35100818

Help for Users in Indonesia

Contacts for information, support, and services are:

World Wide Web

<http://www.epson.co.id>

- Information on product specifications, drivers for download
- Frequently Asked Questions (FAQ), Sales Enquiries, questions through e-mail

Epson Hotline

Phone: 1500-766 (Indonesia Only)

Email: customer.care@ein.epson.co.id

Our Hotline team can help you with the following over the phone or email:

- Sales enquiries and product information
- Technical support

Help for Users in Hong Kong

To obtain technical support as well as other after-sales services, users are welcome to contact Epson Hong Kong Limited.

Internet Home Page

<http://www.epson.com.hk>

Epson Hong Kong has established a local home page in both Chinese and English on the Internet to provide users with the following information:

- Product information
- Answers to Frequently Asked Questions (FAQs)
- Latest versions of Epson product drivers

Technical Support Hotline

You can also contact our technical staff at the following telephone and fax numbers:

Phone: 852-2827-8911

Fax: 852-2827-4383

Help for Users in Malaysia

Contacts for information, support, and services are:

World Wide Web

<http://www.epson.com.my>

- Information on product specifications, drivers for download
- Frequently Asked Questions (FAQ), Sales Enquiries, questions through e-mail

Epson Call Centre

Phone: 1800-81-7349 (Toll Free)

Email: websupport@emsb.epson.com.my

- Sales enquiries and product information
- Product usage questions or problems
- Enquiries on repair services and warranty

Epson Malaysia Sdn Bhd (Head Office)

Phone: 603-56288288

Fax: 603-5628 8388/603-5621 2088

Help for Users in India

Contacts for information, support, and services are:

World Wide Web

<http://www.epson.co.in>

Information on product specifications, drivers for download, and products enquiry are available.

Toll Free Helpline

For Service, Product information or to order consumables -

18004250011 / 186030001600 / 1800123001600 (9AM – 6PM)

Email

calllog@epson-india.in

WhatsApp

+91 96400 00333

Help for Users in the Philippines

To obtain technical support as well as other after sales services, users are welcome to contact the Epson Philippines Corporation at the telephone, fax numbers and e-mail address below:

World Wide Web

<http://www.epson.com.ph>

Information on product specifications, drivers for download, Frequently Asked Questions (FAQ), and E-mail Enquiries are available.

Epson Philippines Customer Care

Toll Free: (PLDT) 1-800-1069-37766

Toll Free: (Digitel) 1-800-3-0037766

Metro Manila: +632-8441-9030

Web Site: <https://www.epson.com.ph/contact>

E-mail: customercare@epc.epson.com.ph

Accessible 9am to 6pm, Monday through Saturday (Except public holidays)

Our Customer Care team can help you with the following over the phone:

- Sales enquiries and product information
- Product usage questions or problems
- Enquiries on repair service and warranty

Epson Philippines Corporation

Trunk Line: +632-8706-2609

Fax: +632-8706-2663 / +632-8706-2665

Help for Users in South Korea

Customer Support Website

<https://www.epson.co.kr/sl/s>

Without area code

1566-3515

Printer, Projector, Label Printer (for Home Use)

1588-3515

Large Printer, Large Multifunction Printer, Scanner, Laser Printer, Dot Matrix Printer, Label Printer (for Business Use)