

# ML-32000-340 ML-32000-180 / ML-16000-180 Maintenance Guide

---

**Before Starting Maintenance Work**

**Maintenance Work List**

**Inspection/Cleaning Procedure**

**Adjustment Procedure**

**Replacement Procedure**

**Glue Re-Application**



## Cautions

- No part of this document may be reproduced, stored in a retrieval system, or transmitted in any form or by any means, electronic, mechanical, photocopying, recording, or otherwise, without the prior written permission of Seiko Epson Corporation.
- The contents of this document are subject to change without notice. Please contact us for the latest information.
- While every precaution has been taken in the preparation of this document, Seiko Epson Corporation assumes no responsibility for errors or omissions.
- Neither is any liability assumed for damages resulting from the use of the information contained herein.
- Neither Seiko Epson Corporation nor its affiliates shall be liable to the purchaser of this product or third parties for damages, losses, costs, or expenses incurred by the purchaser or third parties as a result of: accident, misuse, or abuse of this product or unauthorized modifications, repairs, or alterations to this product, or (excluding the U.S.) failure to strictly comply with Seiko Epson Corporation's operating and maintenance instructions.
- Seiko Epson Corporation shall not be liable against any damages or problems arising from the use of any options or any consumable products other than those designated as Original EPSON Products or EPSON Approved Products by Seiko Epson Corporation.

## Trademarks

SuperPolx® is a registered trademark of Berkshire Corporation.

All other trademarks are the property of their respective owners and used for identification purpose only.

## Manual Organization

The manuals for the product are organized as shown below.

The latest manuals are available from qualified service personnel.

- ML-32000-340 / ML-32000-180 / ML-16000-180 Safety Precautions:  
This manual explains the safety precautions. Make sure you read this manual to perform operations safely.
- ML-32000-340 / ML-32000-180 / ML-16000-180 Operation Guide:  
This manual explains how to use the printer.
- ML-32000-340 / ML-32000-180 / ML-16000-180 Maintenance Guide:  
This manual explains how to perform maintenance of the printer.
- Leonardo Reference Guide:  
This manual explains how to use Leonardo.

## Images Used in this Manual

The images used in this document may vary from your machine.

Unless otherwise stated, this document uses images of the ML-32000-180.

©Seiko Epson Corporation 2021–2024

# Important Safety Information

This section describes the symbols that are used both in this manual and on this machine.



Be sure to read this manual and the separate "Safety Precautions" carefully before using this machine. Store this manual in a safe location where it can be easily referred to whenever you have a question.









## Meaning of Marks

The following symbols are used in this manual and on this machine to ensure that this machine is used safely and correctly in order to prevent injury to the user and other persons and damage to property.



Please carefully read and understand these warnings before using this machine.

### Symbols in This Manual

 <b>WARNING</b>	This symbol indicates that incorrect operation could result in death or serious injury.
 <b>CAUTION</b>	This symbol indicates that incorrect operation could result in injury and/or damage to property.

				
Indicates actions that must not be taken (prohibited actions).	Indicates actions that must be taken and/or instructions that must be followed.	Do not disassemble	Do not touch	No flames
				
Eye protection must be worn	Protective gloves must be worn	Protective clothing must be worn	Respiratory protection must be worn	Hair net required

## User Permissions

	<p>This symbol indicates user permissions for general users who have been trained in the operation of the machine by Epson or an H user, to perform cleaning and simple maintenance procedures while protective devices are engaged and the machine is set to normal operation on the button panel.</p> <p>“L” is assigned to the operator of the machine.</p>
	<p>This symbol indicates user permissions for users who have been officially trained in the operation of this machine by Epson or an H user, to perform some functions and maintenance procedures that are allowed in addition to all of the functions for L.</p> <p>“H” is assigned to the machine administrator, who manages maintenance keys and is in control of jobs in general.</p> <p>This user must inform User L of the information in this manual, and have access to the manual at all times.</p> <p>Checks and maintenance can be performed routinely or in unusual situations only if formal training has been received from Epson or an H user.</p> <p>It is strongly recommended to make all L users aware of their responsibilities when operating this machine. To that end, it is also important to collect from them all information regarding recommendations, complaints, suggestions, and anomalies that might occur.</p>

# Contents

■ Important Safety Information .....	3
Meaning of Marks .....	3
■ Contents.....	5

---

## ***Before Starting Maintenance Work*** ..... 8

■ Precautions for Maintenance Work .....	8
■ Machine Status During Maintenance Work .....	10
Power Off Status .....	10
Printing Standby Status .....	10
■ List of Maintenance Tools and Supplies.....	12
■ Checks Before Maintenance Work .....	14

---

## ***Maintenance Work List*** ..... 15

■ Inspection/Cleaning .....	15
■ Adjustment/Replacement .....	17
■ Other Maintenance.....	17

---

## ***Inspection/Cleaning Procedure*** ..... 18

■ Checking the Area Around Operating Parts .....	18
■ Disposing of Waste Ink.....	19
Disposing of Waste Ink of the Cleaning Station .....	20
Disposing of Waste Ink of the Flushing Plate.....	22
■ Inspecting the Emergency Stop Buttons and Emergency Stop Rope Switch.....	26
■ Inspecting the Open Cover Detection .....	26
■ Inspecting for Leaks in the Ink Path .....	26
■ Checking the Filter on the Air Supply Regulator .....	27
■ Cleaning the Area Around the Caps and Wipers.....	28
■ Cleaning the Flushing Plate .....	32
■ Checking the height with the foreign material detection sensor .....	34
ML-32000-180.....	34
ML-32000-340 / ML-16000-180 .....	37
■ Cleaning the Belt and Removing Ink Film (When Using Pigment Ink) .....	40
Cleaning Ink Stains on the Belt .....	40
Removing Ink Film .....	43

■ Cleaning the Area around the Head and Inspecting the Ink Rack.....	55
ML-32000-180.....	55
ML-32000-340 / ML-16000-180.....	64
■ Cleaning the Cleaning Brushes and the Area Around Them .....	72
■ Cleaning the Sponge Roller (ML-32000-340).....	75
■ Cleaning the Head Cover.....	78
■ Cleaning the Plate (Guide Beside the Belt) .....	79
■ Cleaning the Carriage Operating Parts on the Print Heads .....	81
■ Adding Grease to the Scan Spindle .....	84
ML-32000-180.....	84
ML-32000-340 / ML-16000-180.....	94
■ Checking for Water Leaks in the Pipe Joints .....	99
■ Cleaning/Replacing the Mist Filter .....	100
■ Checking the Blower and Cleaning/Replacing the Filter.....	102
■ Cleaning/Replacing the Cooling Fan Filters.....	104
Cleaning the Cooling Fan Filters.....	104
Replacing the Cooling Fan Filters.....	108
■ Checking the Cable Protection Condition.....	111
■ Shaking the Ink Cartridges.....	112

---

***Adjustment Procedure .....*** 114

■ Bi-directional Adjustment.....	114
■ Belt Feed Amount Adjustment.....	116

---

***Replacement Procedure .....*** 118

■ Cap Replacement .....	118
■ Wiper Unit Replacement.....	122
■ Towel Roller Fabric Replacement .....	126
■ Replacing the Washing T-shaped Scraper .....	130
■ Replacing the Washing Silicone Scraper .....	134
■ Sponge Roller Replacement (ML-32000-340).....	136
■ Pressure Roller Replacement .....	142

---

***Glue Re-Application.....*** 145













■ Glue Removal.....	145
---------------------	-----







---















Preparation.....	148
Changing Leonardo to Glue Application Mode.....	158
Glue Removal.....	159
Belt Surface Cleaning.....	161
Clean-Up.....	162
<b>■ Glue Application.....</b>	<b>163</b>
Preparation.....	167
Glue Preparation.....	173
Glue Application (1st Layer).....	174
Glue Application (2nd Layer).....	175
Blade Removal.....	178
Drying.....	179
Work After Application.....	180

# Before Starting Maintenance Work

## Precautions for Maintenance Work

 <b>WARNING</b>	
	<p>If using glue, glue remover, or ink film remover that contains flammable gas, explosive gas, or the like, ensure sufficient ventilation and make sure that the ignition point and explosion limit are not reached.</p> <p>For details, refer to the instructions of the SDS for the glue, glue remover, and ink film remover you are actually using.</p>
      	<p>Do not operate this machine or the computer while maintenance is being performed. When performing maintenance work in a location that is out of sight of the control PC operator, make sure that only the person performing maintenance work and no one else is able to operate the control PC.</p> <p>Doing so leads to the risk of your hand or other parts of your body becoming caught in the machine.</p>
 	<p>Do not operate this machine if you have a pacemaker. The electromagnetic waves that are generated by this machine can affect the operation of pacemakers.</p>
 	<p>This machine generates a strong magnetic field. Do not use precision equipment such as watches and mobile phones nearby. Precision equipment could malfunction or become damaged by the strong magnetic field.</p>

 <b>CAUTION</b>	
    	<p>During maintenance work, wear all the protective equipment described in "Personal Protective Equipment" (eye protection, protective gloves, respiratory protection, etc.) in each section below.</p> <ul style="list-style-type: none"> <li>• Use protective equipment compliant with the safety regulations.</li> <li>• Using additional protective equipment compliant with the safety regulations is recommended when necessary.</li> </ul>
	<p>Be sure to wear eye protection during maintenance work on areas near the ink path, such as when cleaning around the heads and caps.</p> <p>Failure to do so could cause ink to splash into the eyes.</p>

	<b>Be sure to wear protective gloves when using maintenance liquid.</b>
 	<b>Be sure to wear eye protection and respiratory protection when applying glue or removing ink film.</b> For details, refer to the instructions of the SDS for the glue, glue remover, and ink film remover you are actually using.
	<b>Long hair should be tied back and worn under a hair net.</b> Otherwise, your hands and clothing could become stained with ink, and your fingers and hair could become caught in the machine.
 	<b>Do not allow any person on the machine while working. Note that the machine is not designed to support the weight and can be easily damaged. When performing maintenance to parts on the upper part of the machine, use a tool, such as a step stool, appropriate for the work.</b> <b>Failure to do so could lead to injury or damage to the machine.</b>
	<b>If waste ink or maintenance liquid gets on the floor, use a wipe cloth or the like to wipe it up. Failure to do so could lead to injury due to slipping.</b>
	<b>Make sure that all maintenance work is performed at room temperature.</b>
	<b>When maintenance work is completed, immediately return the protective equipment to its original location.</b>
	<b>Make sure that no tools or parts used in maintenance work, or other foreign materials are left on the operating parts of the machine or inside the machine.</b>
	<b>During maintenance, do not use sharpening stones, abrasive/corrosive materials, or solvents (excluding glue and ink film remover).</b> Doing so may erase numbers, codes or characters indicated on the machine.
	<b>Do not expose the electrical and electronic devices, and motors to liquid.</b>
	<b>Do not touch the micro switches on the alarm or on the front/rear cover.</b>
	<b>Use the products properly according to the "Safety Data Sheet" for each product.</b>

## Machine Status During Maintenance Work

To ensure that maintenance work is done safely, for step 1 of each procedure, check that the machine is in the indicated status.

The following explains each status and the procedure to put the machine in that status.

### Power Off Status

The machine's main power switch is in 0 (OFF) and the power is off. Work which involves touching or entering the machine's operating parts is done in this status.

If the machine's power is on, turn the power off using the following procedure.

- 1 Press the emergency stop button.**
- 2 Close the Leonardo screen and shut down the control PC.**
- 3 Turn the main power switch to 0 (OFF) to turn the power off.**



When performing maintenance after finishing a day's printing work, refer to "Workflow When Turning Off the Power" in the "Operation Guide".

### Printing Standby Status

The machine's power is on, Leonardo has been started, and printing is possible. Green on the tower lamp is lit up. Operations performed after moving the machine's operating parts (print head carriage, etc.) are started from this status. If the machine is not in the Printing Standby Status, perform the following procedure.

#### **If the machine's power is off:**

Turn on the power and then execute Set point. Refer to "Workflow before Beginning Work" in the "Operation Guide" for details.

#### **If the machine's power is on but it is not in Printing Standby Status:**

Execute Set point using the following procedure.





- 1** Check the area around the operating parts.
- 2** Check that the covers on the front and rear sides are closed.
- 3** Release all emergency stop buttons for this machine and any linked devices (if they have been pressed).
- 4** On the Leonardo operation screen, click [Setpoint] and then press the reset button on the main electric box.





If an error message is output and you cannot perform Set point, refer to "Troubleshooting" in the "Operation Guide".

## List of Maintenance Tools and Supplies

Prepare the items listed below before starting inspection/cleaning.

Item	Details/Use
Cleaning stick (Dedicated consumables/commercially available) 	Use for cap and wiper cleaning Epson recommends the following if purchasing yourself: ASPURE from AS ONE Corporation Model no.: AP125PCT
Cleaning cloth (Dedicated consumables/commercially available) 	Nonwoven fabric for head cleaning Epson recommends the following if purchasing yourself: Berkshire Corporation SuperPolx® 1200
Maintenance liquid (Dedicated consumables)	Cleaning liquid especially for maintenance of this machine Do not dilute the liquid.
Grease pump (Bundled item) 	Used for adding grease to the scan spindle.
Grease (Commercially available)	Grease added to the scan spindle. Epson recommends the following: NSK Ltd. Model no.: NSK GRS AS2
Plastic container (Commercially available) 	Used to contain the maintenance liquid or tap water. Epson recommends the following: Disposable cup
Rubber gloves (Commercially available)	Use during cleaning.

Item	Details/Use
Eye protection (Commercially available) 	Use during cleaning of the area around the head, caps, and wipers, and when replacing the head.
Plastic tweezers (Commercially available)	Use for cap cleaning
Hex key (Commercially available) 	Used to fasten or loosen screws on the machine.
Spanner (width: 7 mm) (Commercially available) 	Used to fasten or loosen screws on the machine.
Flashlight (Commercially available)	Used when working in the ink rack housing.
Scraper/Brush (Commercially available)	Use for flushing plate cleaning
Forceps (Commercially available)	Use for cap unit replacement. Use a type that cannot damage the ink tube.
Replacement waste ink tank (Models with waste ink tanks only) (Commercially available)	Used for replacing the waste ink tank installed on the flushing plate side.

## Checks Before Maintenance Work

Do not place tools, fasteners, or the like on the belt or near the pressure roller or print head. Doing so could cause them to be entangled in the belt, pressure roller, or print head, damaging this machine. Before turning the power on, check that there is nothing left near the moving parts, such as on the belt or near the print head.

### Front

- 1 Open the front cover of this machine.
- 2 Check that there are no tools, fasteners, or the like left on the belt or near the carriage or print head.



- 3 Close the front cover.

### Rear

- 1 Open the rear cover of this machine.
- 2 Check that there are no tools, fasteners, or the like left near the belt or the pressure roller.



- 3 Close the rear cover.

# Maintenance Work List

## Inspection/Cleaning

Category	Item	Inspection Frequency					User Permissions	Procedure Details
		Every shift	Everyday	Every week	Every month	Every six months		
Inspection/Cleaning	<input type="checkbox"/> Checking the area around operating parts	✓						L <a href="#">Page 18</a>
	<input type="checkbox"/> Disposing of Waste Ink of the Cleaning Station		✓					L <a href="#">Page 20</a>
	<input type="checkbox"/> Disposing of Waste Ink of the Flushing Plate						✓	H <a href="#">Page 22</a>
	<input type="checkbox"/> Inspecting the emergency stop button		✓					L <a href="#">Page 26</a>
	<input type="checkbox"/> Inspecting the open cover detection		✓					L <a href="#">Page 26</a>
	<input type="checkbox"/> Inspecting for leaks in the ink path		✓					L <a href="#">Page 26</a>
	<input type="checkbox"/> Checking the filter on the air supply regulator		✓					L <a href="#">Page 27</a>
	<input type="checkbox"/> Cleaning the area around the caps and wipers		✓				✓	L <a href="#">Page 28</a>
	<input type="checkbox"/> Cleaning the flushing plate		✓					L <a href="#">Page 32</a>
	<input type="checkbox"/> Checking the height with the foreign material detection sensor		✓				✓ <sup>*1</sup>	L <a href="#">Page 34</a>
	<input type="checkbox"/> Cleaning the ink stains on the belt (pigment ink)		✓					L <a href="#">Page 40</a>
	<input type="checkbox"/> Removing the ink film on the belt (pigment ink)						✓	L <a href="#">Page 43</a>
	<input type="checkbox"/> Cleaning the area around the head and inspecting the ink rack			✓			✓	H <a href="#">Page 55</a>
	<input type="checkbox"/> Cleaning the cleaning brushes and the area around them			✓			✓ <sup>*2</sup>	L <a href="#">Page 72</a>
<input type="checkbox"/> Cleaning the Sponge Roller (ML-32000-340)			✓			✓	L <a href="#">Page 75</a>	

Category	Item	Inspection Frequency					User Permissions	Procedure Details
		Every shift	Everyday	Every week	Every month	Every six months		
Inspection/Cleaning	<input type="checkbox"/> Cleaning the head cover						✓	L <a href="#">Page 78</a>
	<input type="checkbox"/> Cleaning the plate (guide beside the belt)						✓	L <a href="#">Page 79</a>
	<input type="checkbox"/> Cleaning the carriage operating parts on the print heads				✓			L <a href="#">Page 81</a>
	<input type="checkbox"/> Adding grease to the scan spindle					✓		H <a href="#">Page 84</a>
	<input type="checkbox"/> Checking for water leaks in the pipe joints				✓			L <a href="#">Page 99</a>
	<input type="checkbox"/> Cleaning/Replacing the mist filter				✓ Cleaning		✓ Replace- ment	L <a href="#">Page 100</a>
	<input type="checkbox"/> Checking the blower and cleaning/ replacing the filter				✓ Inspection		✓ Cleaning/ Replace- ment	L <a href="#">Page 102</a>
	<input type="checkbox"/> Cleaning/Replacing the cooling fan filters				✓		✓	L <a href="#">Page 104</a>
	<input type="checkbox"/> Checking the cable protection condition				✓			L <a href="#">Page 111</a>

\*1: When changing the fabric type

\*2: After printing on fabric with fuzzy surface

## Adjustment/Replacement

Category	Item	Inspection Frequency					User Permissions	Procedure Details
		Every shift	Everyday	Every week	Every month	Every six months		
Adjustment	<input type="checkbox"/> Bi-directional adjustment						✓ <sup>*1</sup>	H <a href="#">Page 114</a>
	<input type="checkbox"/> Belt feed amount adjustment						✓ <sup>*2</sup>	H <a href="#">Page 116</a>
Replacement	<input type="checkbox"/> Cap unit replacement.						✓	L <a href="#">Page 118</a>
	<input type="checkbox"/> Wiper replacement					✓		L <a href="#">Page 122</a>
	<input type="checkbox"/> Towel roller fabric replacement						✓	L <a href="#">Page 126</a>
	<input type="checkbox"/> Washing T-shaped Scraper Replacement						✓	L <a href="#">Page 130</a>
	<input type="checkbox"/> Washing silicone scraper replacement						✓	L <a href="#">Page 134</a>
	<input type="checkbox"/> Sponge Roller Replacement (ML-32000-340)						✓	L <a href="#">Page 136</a>
Glue Re-Application	<input type="checkbox"/> Pressure roller replacement						✓	L <a href="#">Page 142</a>
	<input type="checkbox"/> Glue Removal						✓	H <a href="#">Page 145</a>
	<input type="checkbox"/> Glue Application						✓	H <a href="#">Page 163</a>

\*1: When replacing heads/When changing jobs

\*2: When irregular streaking occurs/When changing jobs

## Other Maintenance

- Shaking the ink cartridges ([Page 112](#))

# Inspection/Cleaning Procedure

## Checking the Area Around Operating Parts

Frequency	Every shift
User Permissions	L
Personal Protective Equipment	Protective gloves and clothing

- 1** Check that the machine is in the Power Off Status.  
(For more information, refer to "Power Off Status" on Page 10.)
- 2** Make sure that no tools or other items are left on operating parts such as the print head operating area [1] and the carriage operating area [2]. If any item is left, remove it.

Front

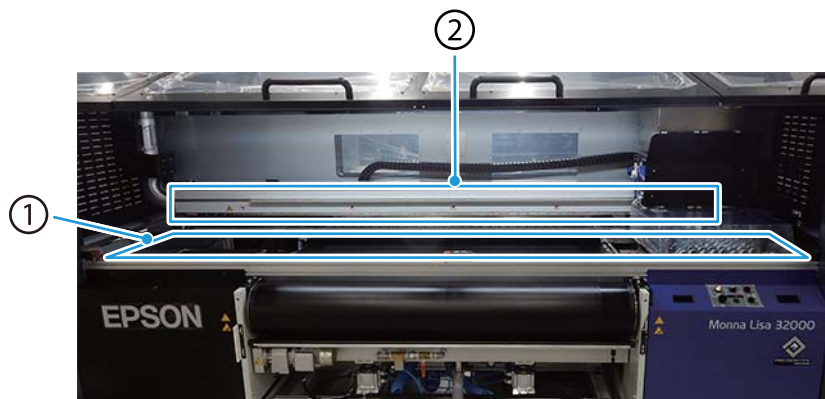

Rear



## Disposing of Waste Ink

Implement this procedure when using the ML-32000-180.

Dispose of the waste ink in the waste ink tanks located below the cleaning station (1: Front right) and below the flushing plate (2: Front left).

Cleaning station side



Flushing plate side

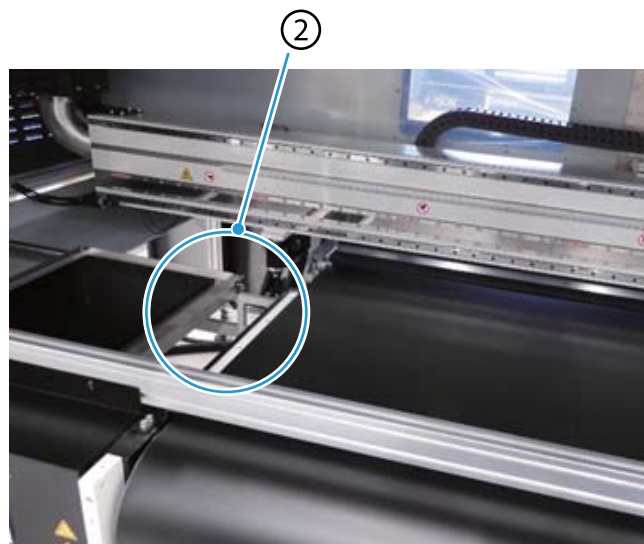

## Disposing of Waste Ink of the Cleaning Station

Frequency	Inspection: Everyday, before beginning work Disposal: Everyday, when printing ends
User Permissions	L
Personal Protective Equipment	Protective gloves and clothing

- 1** Check that the machine is in the Power Off Status.  
(For more information, refer to ["Power Off Status" on Page 10.](#))
- 2** Prepare the waste ink tank lid.



- 3** Slide the waste ink tank cover horizontally to remove it.



- 4** Make sure the waste ink tank does not contact the drain of the waste ink pipe when removing it.

- 5** Securely close the waste ink tank lid.



- 6** Dispose of the waste ink in the proper manner.
- 7** Set an empty waste ink tank in the original position.  
Check that the mouth of the waste ink tank sits directly below the drain of the waste ink pipe.
- 8** Slide the waste ink tank cover horizontally to install it.



This completes the work.

## Disposing of Waste Ink of the Flushing Plate

Frequency	Inspection: Everyday, before beginning work Disposal: Dispose as necessary
User Permissions	H
Personal Protective Equipment	Eye protection, protective gloves and clothing
Required Items	Replacement waste ink tank

	Check that the amount of waste ink in the waste ink tank is not such that the waste ink will spill out.
---	---

- 1** Check that the machine is in the Power Off Status.  
(For more information, refer to "Power Off Status" on Page 10.)
- 2** Remove the six screws from the side cover.



- 3** Lift the side cover handle and remove the cover.

 <b>CAUTION</b>	<p>When removing the side cover, be careful not to damage the interlock key in the upper center of the back of the cover. If this key is not inserted, this machine will not operate.</p> <p style="text-align: center;">Interlock key</p> 
--	---

**4** Grab the handle on the ink rack with both hands, and pull it out from the ink rack housing.

	<p>Be careful of the following so as not to damage the cables:</p> <ul style="list-style-type: none"> <li>• Do not allow the ink rack wheels to run over the cables.</li> <li>• Do not pull the cables hard or apply excessive force.</li> </ul>
---	--

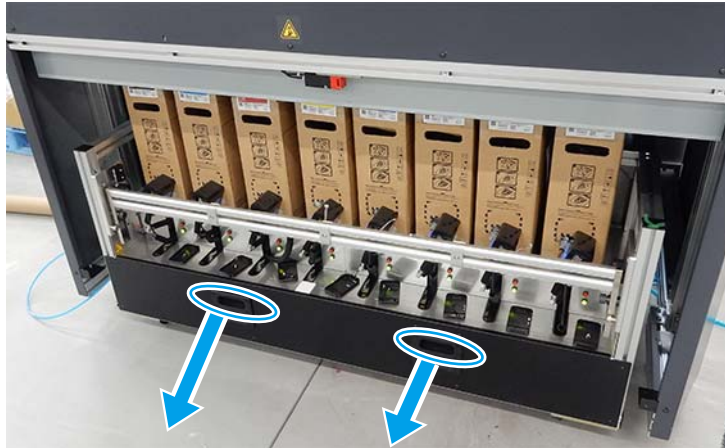

**5** Wear eye protection.

 <p><b>CAUTION</b></p>	<p>Be sure to wear eye protection. Failure to do so could cause ink to splash into the eyes.</p>
---	--

- 6** Enter the ink rack housing with the replacement waste ink tank.
- 7** Remove the waste ink tube from the waste ink tank and insert it into the new waste ink tank.



Carefully remove the waste ink tube. Pulling it out with force may result in ink splashing.



Waste ink tube

- 8** Securely close the lid of the waste ink tank containing waste ink.
- 9** Exit the ink rack housing with the waste ink tank containing waste ink.
- 10** Return the ink rack to the original position.

- 11** Attach the side cover. Place the protrusions on the lower left and right sides of the side cover on the guide of the machine, and insert the key of the side cover into the interlock.

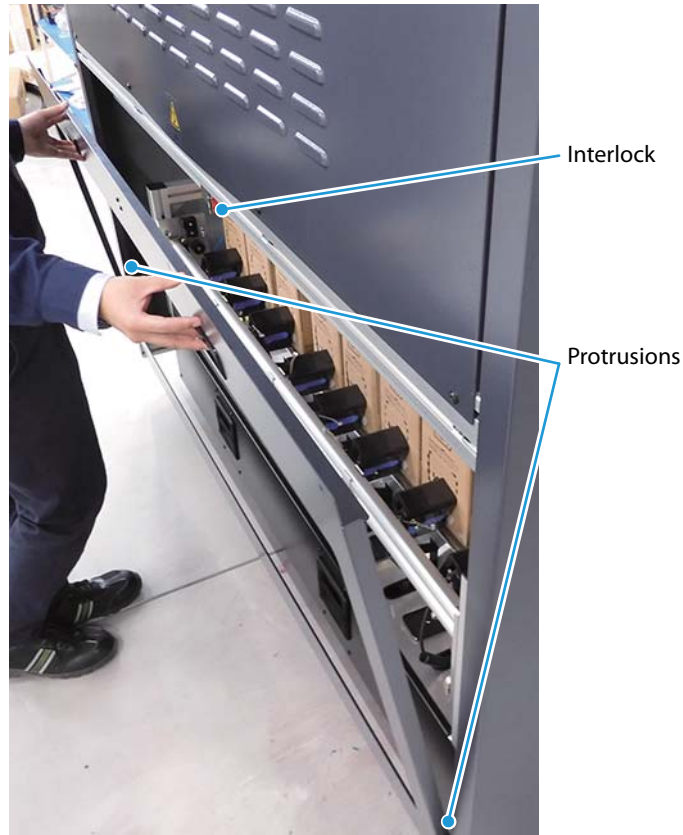

- 12** Tighten the six screws on the side cover.
- 13** Dispose of the waste ink in the proper manner.

This completes the work.

## ***Inspecting the Emergency Stop Buttons and Emergency Stop Rope Switch***

Frequency	Everyday Inspection before beginning work
User Permissions	L
Personal Protective Equipment	Protective gloves and clothing

Check that the emergency stop button operates normally.

When using the ML-32000-340 or ML-16000-180, confirm that the emergency stop rope switch also operates properly.

For detailed procedures, refer to the "Operation Guide".

## ***Inspecting the Open Cover Detection***

Frequency	Everyday Inspection before beginning work
User Permissions	L
Personal Protective Equipment	Protective gloves and clothing

Check that the cover open detection function on the front/rear side is operating normally.

For detailed procedures, refer to the "Operation Guide".

## ***Inspecting for Leaks in the Ink Path***

Frequency	Everyday
User Permissions	L
Personal Protective Equipment	Protective gloves and clothing

Check for ink leaks in each ink path. Check for ink leaks or runs around the connections between the heads and tubes, and around the print heads.

For detailed procedures, refer to the "Operation Guide".

## *Checking the Filter on the Air Supply Regulator*

Frequency	Everyday
User Permissions	L
Personal Protective Equipment	Protective gloves and clothing

Check the filter on the air supply regulator for impurities and moisture. For the inspection procedure, refer to the "Operation Guide".

## Cleaning the Area Around the Caps and Wipers

Frequency	Every shift
User Permissions	L
Personal Protective Equipment	Protective gloves and clothing
Required Items	Cleaning stick, maintenance liquid, plastic container, tweezers

	For cleaning, be sure to use the dedicated maintenance liquid.
---	--

- 1** Check that the machine is in the Printing Standby Status.  
(For more information, refer to "Printing Standby Status" on Page 10.)
- 2** Move the print head carriage to a position above the flushing plate.  
On the Leonardo operation screen, open [Maintenance] (1), and click [+] (2) for [Carriage] under [Axes] once. When the head carriage moves to the center, click [+] again.  
The carriage moves to the left, to a position above the flushing plate.

	Do not work for a long period of time while the head carriage is uncapped. Doing so can cause the print head nozzles to clog, causing a printing error. Pigment ink in particular causes a failure if left uncapped for 24 hours.
---	---

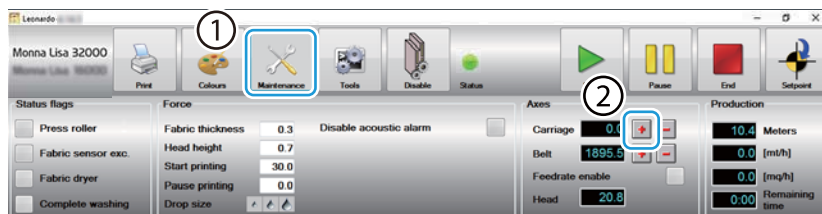

- 3** Press the emergency stop button.
- 4** Close the Leonardo screen and shut down the control PC.
- 5** Turn the main power switch to 0 (OFF) to turn the power off.

**6** Open the front cover.



**7** Lightly wipe off dirt from around the cap using the cleaning cloth or cleaning stick moistened with maintenance liquid.

<p><b>CAUTION</b></p>	<p>Make sure that the machine's power is off before performing work.</p>
	<ul style="list-style-type: none"> <li>• Do not wipe around the cap with force. Doing so may damage the lip section of the cap, deteriorate nozzle recovery by cleaning, or result in nozzle clogging.</li> <li>• Do not allow the cleaning cloth or cleaning stick to touch the absorber or metal part in the cap. Doing so may deform the parts, resulting in damage to the head nozzle surface or nozzle clogging.</li> </ul> <div style="text-align: center;"> <p>Absorber                  Metal part</p> </div>

Wipe off in the direction of the arrows.

For cleaning stick



For cleaning cloth



**8 Remove fluffy dust if adhering around the cap using plastic tweezers.**

	<p>Do not pinch the lip section of the cap with the tweezers. Doing so may damage the lip section, deteriorate nozzle recovery by cleaning, or result in nozzle clogging.</p>  <p>Lip section</p>
---	---



**9 Lightly wipe off dirt from around the wiper using the cleaning cloth or cleaning stick moistened with maintenance liquid. Wipe off in the direction of the arrows. The same applies to the cleaning cloth.**

	<p>Do not pull the rubber part of the wipers.</p>
---	---

Wiper section



Rear side of wiper

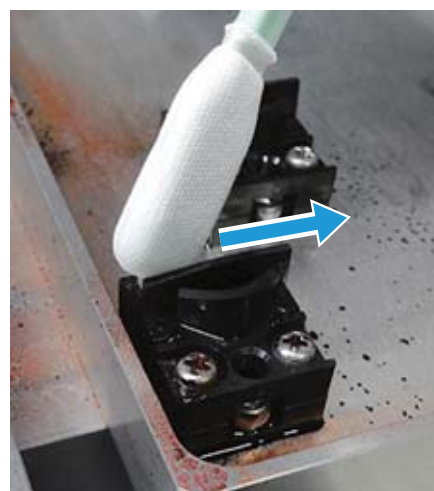

- 10** When cleaning is finished, close the front cover.
- 11** Turn the main power switch to 1 (ON) to turn the power on.
- 12** Start up Leonardo.
- 13** Release the emergency stop button.
- 14** Execute Set point.  
On the Leonardo operation screen, click [Setpoint] and then press the reset button on the main electric box. The print head carriage moves to the cleaning station.

This completes the work.

## Cleaning the Flushing Plate

Frequency	Everyday, when printing ends
User Permissions	L
Personal Protective Equipment	Protective gloves and clothing, eye protection
Required Items	Cleaning stick, scraper/brush

 <b>CAUTION</b>	Be sure to wear eye protection. Failure to do so could cause ink to splash into the eyes.
--	---

Clean away any waste ink that has built up on the flushing plate.

- 1 Check that the machine is in the Power Off Status.**  
(For more information, refer to ["Power Off Status" on Page 10.](#))
- 2 Open the front cover.**



**3 Sweep the ink remaining on the plate into the path at the corner of the plate using the scraper.**

	<p>If waste ink is dried, apply maintenance liquid to dissolve the ink before cleaning.</p>
--	---

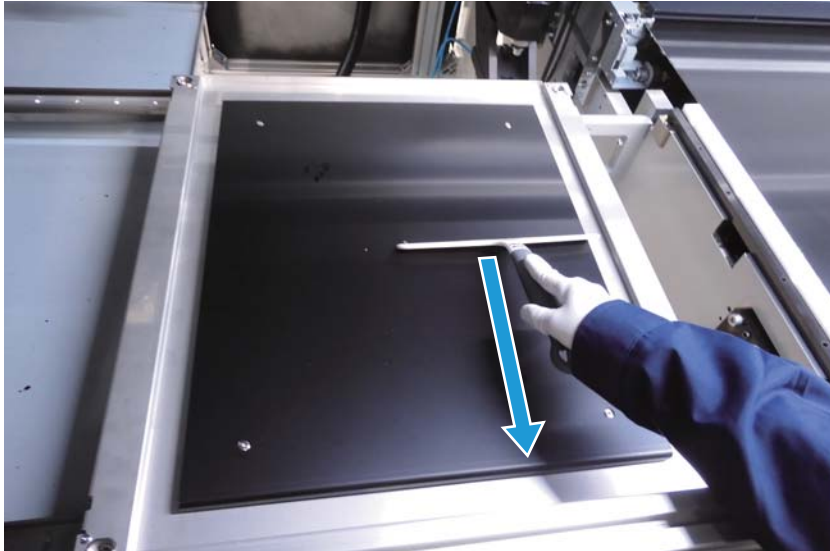

**4 Discharge the waste ink collected in the path from the drain using the cleaning stick or brush.**

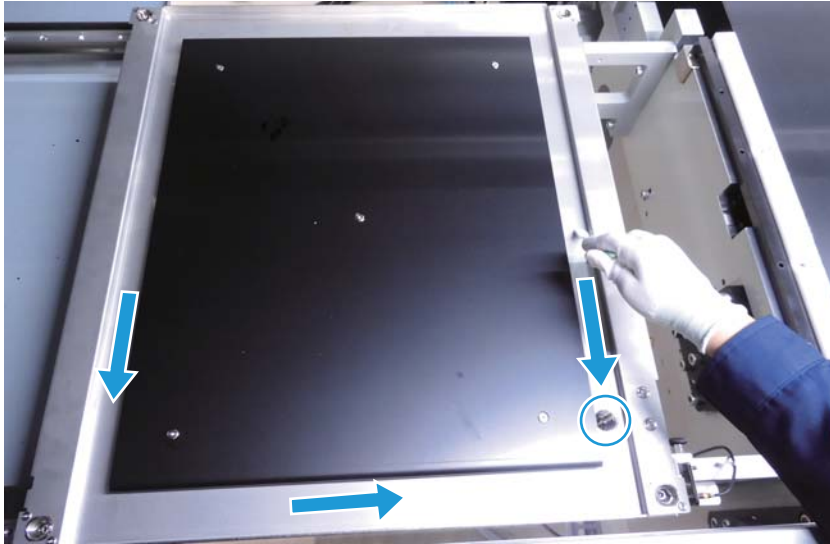

	<p>If it is not connected to the factory's drainage system, check the volume of fluid in the waste ink tank.</p>
--	--

**5 When cleaning is finished, close the front cover.**

This completes the work.

# Checking the height with the foreign material detection sensor

The method for this procedure varies depending on the product in use. When using the ML-32000-340 or ML-16000-180, refer to [“ML-32000-340 / ML-16000-180” on Page 37.](#)

## ML-32000-180

Implement this procedure when using the ML-32000-180.

Frequency	Every week/When a problem occurs, When a large amount of printing is completed
User Permissions	H
Personal Protective Equipment	Protective gloves and clothing, eye protection
Required Items	Hex key (width: 2 mm) or feeler gauge (2 mm)

While there is no fabric loaded, check that the foreign material detection sensor is operating normally. If the user has set a threshold value, reset it to the default value before checking the sensor.

	Do not perform work while the fabric is loaded.
--	---

- 1** Check that the machine is in the Printing Standby Status.  
(For more information, refer to [“Printing Standby Status” on Page 10.](#))
- 2** Open the rear cover.
- 3** Check that there is no fabric loaded, and that there is no foreign material within the detection range of the foreign material detection sensor.



Detection range of the foreign material detection sensor

- 4 Set the foreign material detection sensor switch on the front panel to On.
- 5 Open the cover on the foreign material detection sensor controller.
- 6 If the user has set a threshold value, use (3) to set (1) to 75.0%.
- 7 (4) Press the [PRESET] button.



No	Description
1	Indicates the threshold value. If the light intensity falls below the threshold value (%) specified here, the sensor will be triggered.
2	Indicates the measured light intensity (%).
3	Press ◀ to reduce the threshold value, and ▶ to increase the threshold value. The sensor is more sensitive with a higher threshold value, and less sensitive with a lower threshold value.
4	The light intensity that is measured when the button is pressed is set as 100%. When the fabric thickness is changed, load the fabric and then press this button.

- 8 Confirm that (2) is near 100%.
- 9 Place a hex key (2 mm) or feeler gauge (2 mm) on the belt in front of the foreign material detection sensor.

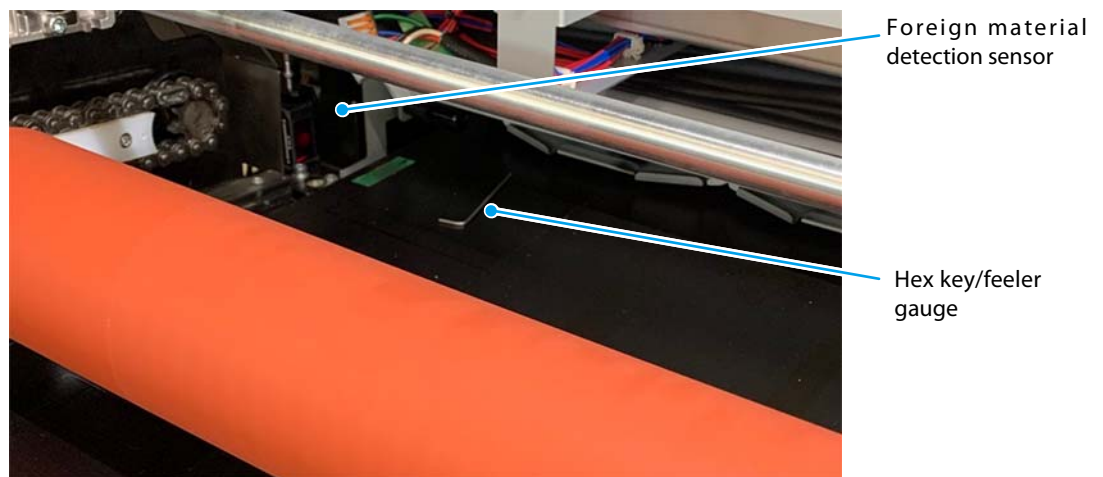

- 10 Confirm that the measurement value on the foreign material detection sensor controller (2) is equal to or less than the threshold value (1).

- 11** Place a hex key (2 mm) or feeler gauge (2 mm) on the belt in front of the reflector plates on the foreign material detection sensor.

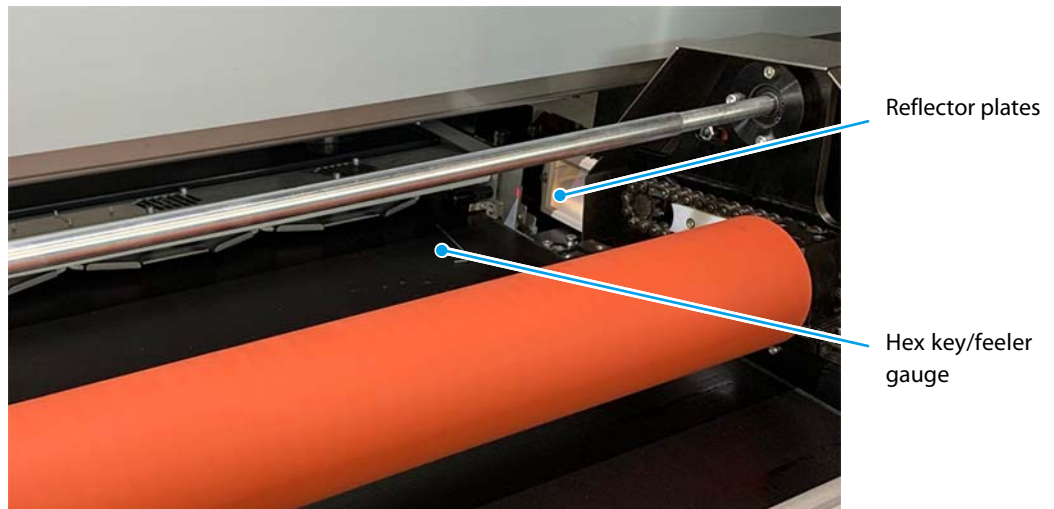

- 12** Confirm that the measurement value on the foreign material detection sensor controller (2) is equal to or less than the threshold value (1).
- 13** If the user has set a threshold value, use (3) to return it to the original value.

This completes the work.

**ML-32000-340 / ML-16000-180**

Implement this procedure when using the ML-32000-340 or ML-16000-180.

Frequency	Every shift/When changing the fabric type
User Permissions	L
Personal Protective Equipment	Protective gloves and clothing
Required Items	Hex key (width: 2 mm) or feeler gauge (2 mm)

While there is no fabric loaded, check that the foreign material detection sensor is operating normally. If the user has set a threshold value, reset it to the default value before checking the sensor.

	Do not perform work while the fabric is loaded.
---	---

- 1** Check that the machine is in the Printing Standby Status.  
(For more information, refer to "Printing Standby Status" on Page 10.)
- 2** Open the rear cover.
- 3** Check that there is no fabric loaded, and that there is no foreign material within the detection range of the foreign material detection sensor.

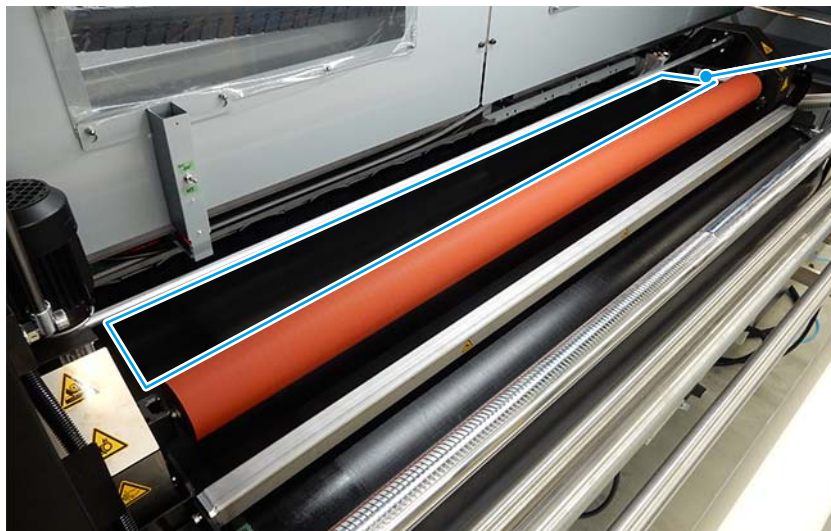

Detection range of the foreign material detection sensor

- 4** Set the foreign material detection sensor switch on the front panel to On.

**5 Before starting work, check the detection threshold value with nothing placed on the belt.**

Check the foreign material detection sensor controller on the front panel to confirm that the displayed value is 9,999 or higher.



**6 Place the hex key (width: 2 mm) or feeler gauge (2 mm) on the front right of the belt.**

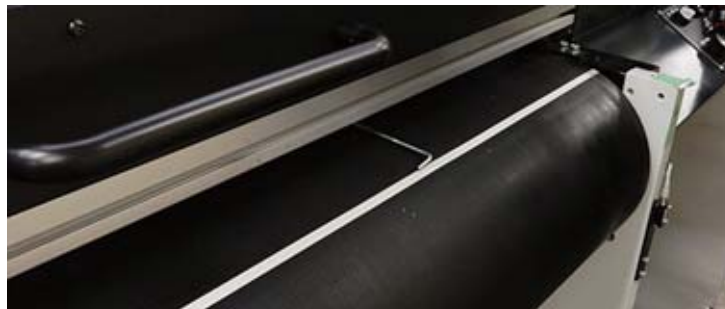

**7 Feed the belt in the reverse direction to the position where the hex key or feeler gauge is exposed the sensor laser beam.**

**8 Move to the machine rear, and check that the tool is exposed to the laser beam through the gap at the top of the pressure roller.**

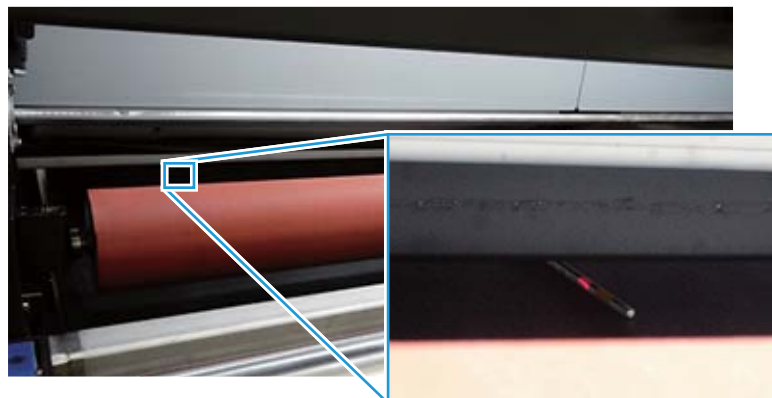





- 9** Check the foreign material detection sensor controller again to confirm that the detection threshold value is 500 or more lower than the previous value.
- 10** Feed the belt in the forward direction and remove the hex key or feeler gauge.
- 11** Place a hex key (width: 2 mm) or feeler gauge (2 mm) on the front left side of the belt, and perform steps 7 to 10.



This completes the work.

## Cleaning the Belt and Removing Ink Film (When Using Pigment Ink)

When pigment ink adheres to the belt, an ink film is formed. When an ink film forms, the adhesive strength of the glue applied to the belt decreases and the fabric attached to the belt becomes more likely to float. To prevent ink film, clean any pigment ink adhering to the belt. Also, if an ink film has formed on the belt, remove the ink film.

### Cleaning Ink Stains on the Belt

Frequency	Everyday, when printing ends	
User Permissions	L	
Required Number of Workers	1 person	
Personal Protective Equipment	The following is the protective equipment that must be worn when using the ethanol recommended by Epson. For details, refer to the instructions of the SDS for the ethanol you are actually using.	
	Eye protection (For organic solvent use; Optimal is a goggle-type that seals against your face)	
		
	Gas mask (For organic solvent use)	
		
	Protective gloves (Butyl or polyurethane)	
		
Protective clothing (Long-sleeved)		
Hat or hair net (Persons with long hair must be tied together with a hair net also worn)		
Safety shoes		

Required Items				
Item	Quantity		Details/Use	
Ethanol	ML-32000-340	Approx. 0.2 L	Commercially available	Removes any ink adhering to the belt. Mix with tap water before use.
	ML-32000-180	Approx. 0.1 L		
	ML-16000-180			
Cleaning bottle 	1		Commercially available	This container is used to hold a cleaning liquid made by mixing tap water and ethanol.
Wipe cloths 	Proper amount		Commercially available	Used to wipe the belt. Use cloths of soft non-fluffy material that will not damage the belt.

**1 Put ethanol and tap water in a bottle and mix well.**

- ML-32000-340  
Ethanol: approx. 0.2 L  
Tap water: approx. 0.2 L
- ML-32000-180 / ML-16000-180  
Ethanol: approx. 0.1 L  
Tap water: approx. 0.1 L

**2 Open the front cover.**

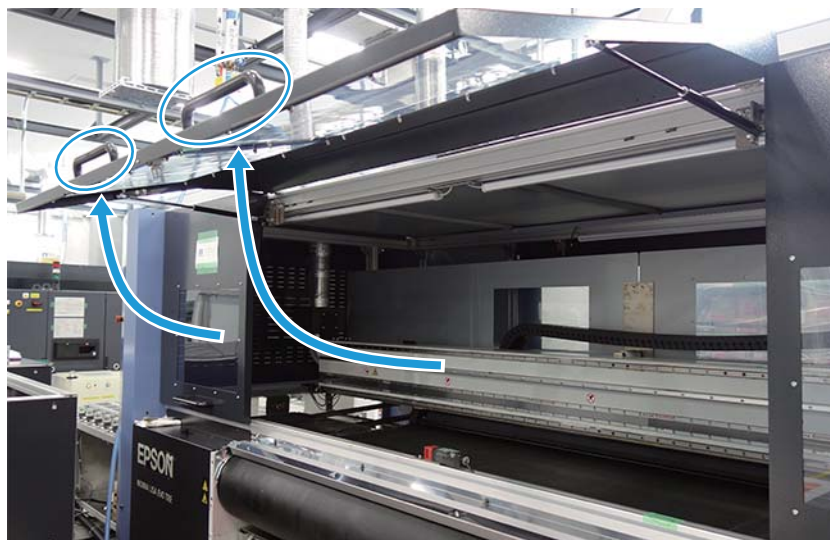

### 3 Soak a wipe cloth with a proper amount of the cleaning liquid made in step 1 and wipe the belt.

Press the feed or back feed button on the front panel to rotate the belt and wipe the belt all the way around.



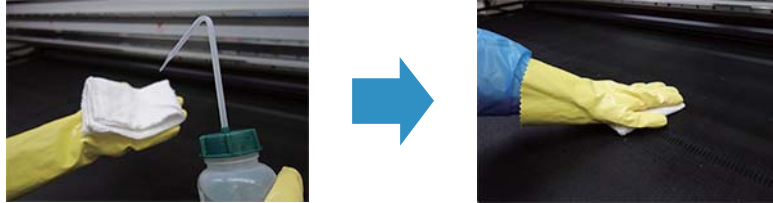

Wring out the wipe cloth and then frequently soak the wipe cloth with the cleaning liquid.



### 4 Close the front cover.

## Removing Ink Film

If an ink film has formed on the belt, remove the ink film.

Frequency	When necessary/When a problem occurs	
User Permissions	L	
Required Number of Workers	1 person	
Personal Protective Equipment	The following is the protective equipment that must be worn when using the ethanol recommended by Epson. For details, refer to the instructions of the SDS for the ethanol you are actually using.	
	Eye protection (For organic solvent use; Optimal is a goggle-type that seals against your face)	
		
	Gas mask (For organic solvent use)	
		
	Protective gloves (Butyl or polyurethane)	
		
Protective clothing (Long-sleeved)		
Hat or hair net (Persons with long hair must be tied together with a hair net also worn)		
Safety shoes		

Required Items				
Item	Quantity		Details/Use	
Ink film remover (for pigment ink)	ML-32000-340	13 L	Recommended product • BP-WASH-SF (Murayama Chemical Laboratory) • NETACOL-VL • FORCLEAN	A solvent that removes ink films that formed on the belt. Mix with tap water before use.
	ML-32000-180	7 L		
	ML-16000-180			

Required Items			
Item	Quantity	Details/Use	
Container	1	Commercially available	This container is used to hold an ink film remover made by mixing tap water and remover.

When using the ML-32000-340 or ML-16000-180, refer to "[ML-32000-340 / ML-16000-180](#)" on Page 44.

When using the ML-32000-180, refer to "[ML-32000-180](#)" on Page 52.

## ML-32000-340 / ML-16000-180



### 1 Put the ink film remover and tap water in the container and mix well.

- ML-32000-340  
 Ink film remover: approx. 13 L  
 Tap water: approx. 10 L
  
- ML-16000-180  
 Ink film remover: approx. 7 L  
 Tap water: approx. 10 L

### 2 Using a flat-head screwdriver, tighten the water supply valve.

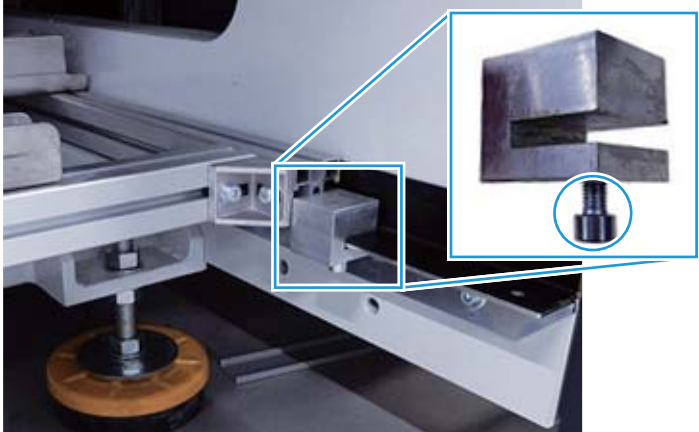

**3** Remove the one screw of each fixing block [2] on the left and right using the hex key (width: 6 mm).

	<p>Store the removed screws to ensure they are not dropped or placed somewhere they can cause damage.</p> <p>Right side</p>  <p>Left side</p> 
---	---

**4** Pull the belt cleaning unit toward you until the carriage rail hits the stopper nearest from you.



**5 Remove the sponge roller and then place it in the sponge roller tank.**

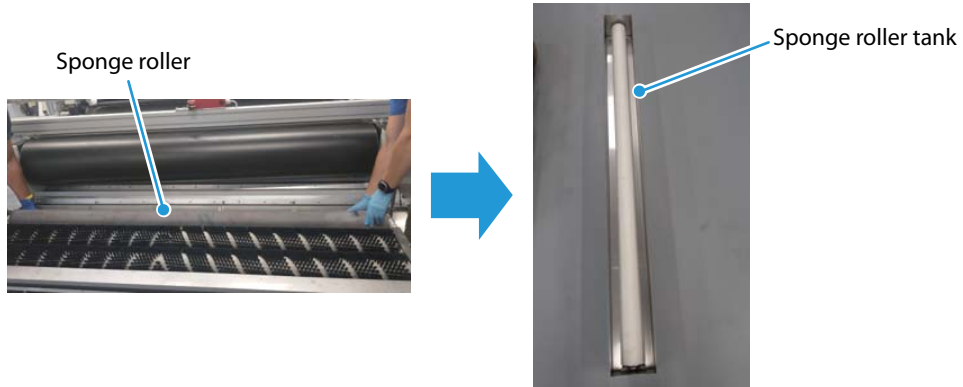

**6 Check to see that water has filled up to the partition of the tank on the bottom of the cleaning brushes.**

If there is not enough water accumulated, use a bucket or the like to pour in tap water.

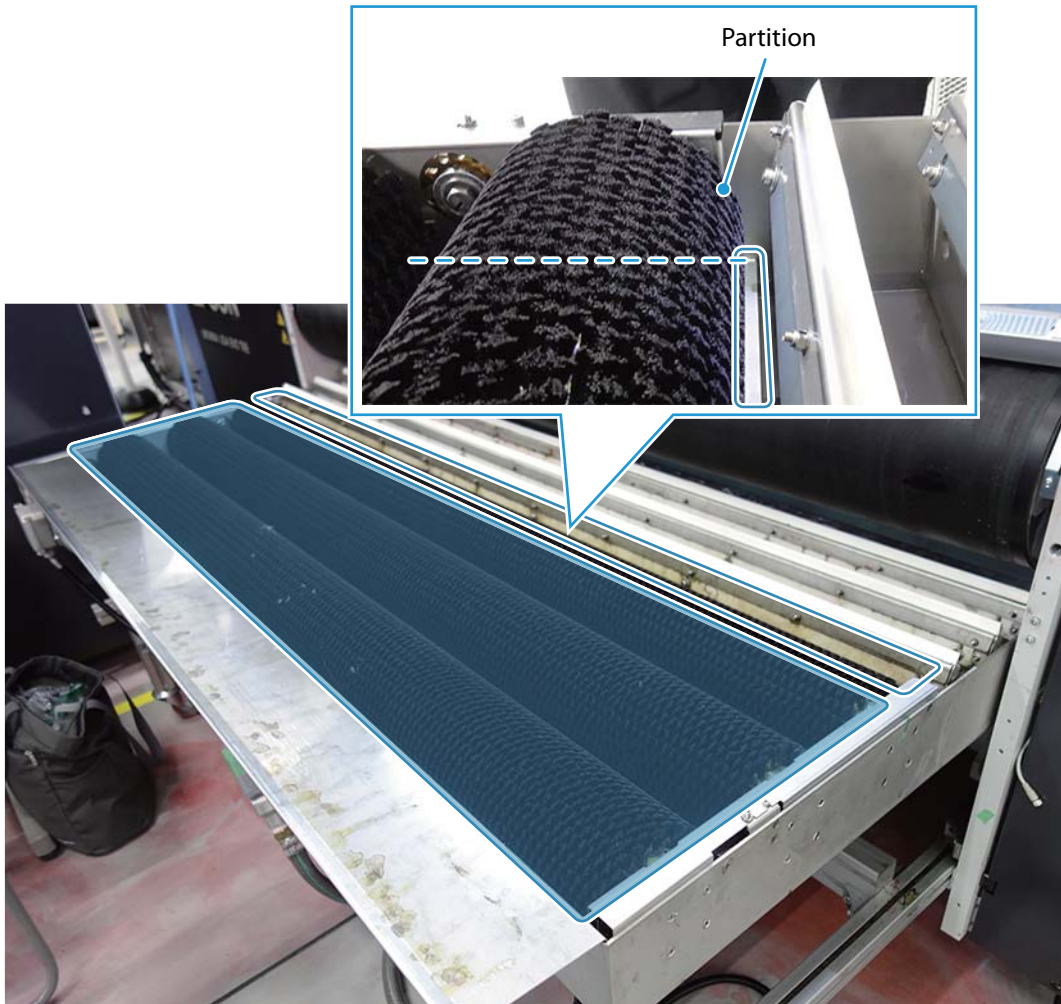

- 7** Check to see that no water remains in the tank at the bottom of the scraper.

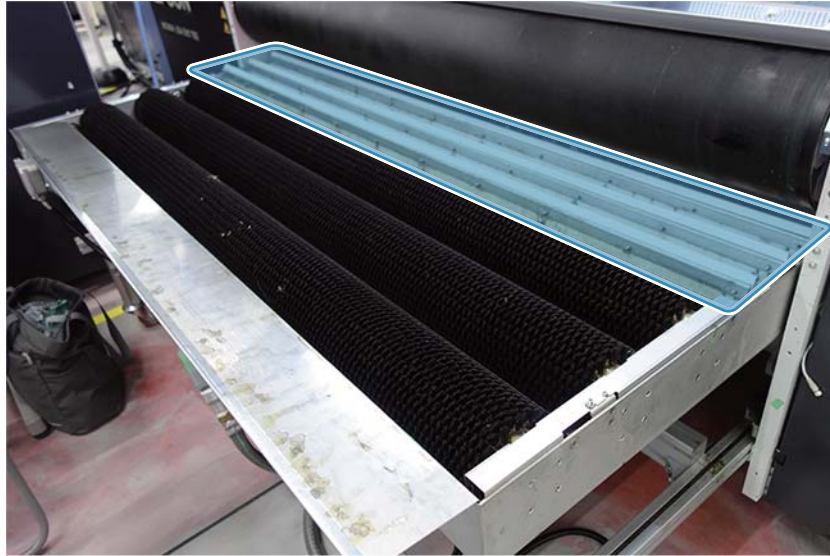

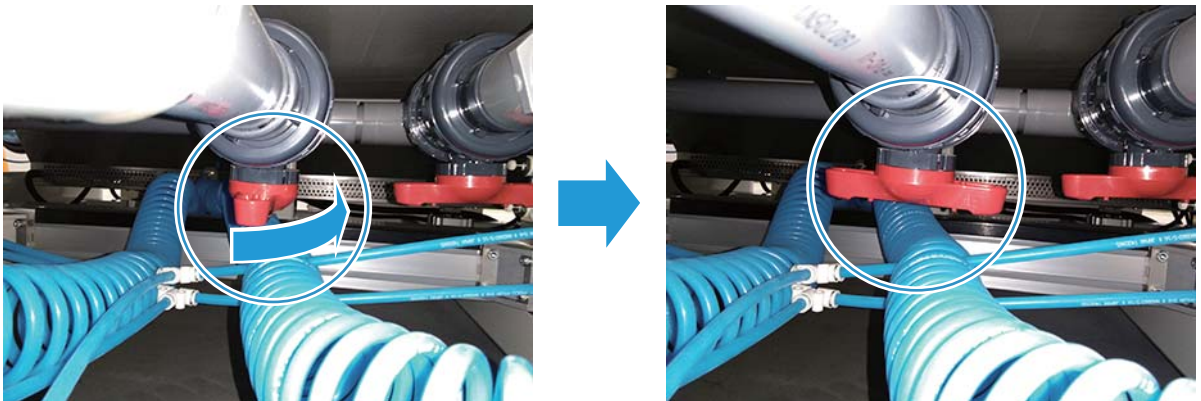

- 8** Turn the left drain valve in the direction of the arrow to close it.



- 9** Pour the ink film remover made in step 1 into the tank on the bottom of the cleaning brushes.



- 10 Return the belt cleaning unit to the carriage rail.
- 11 Push the belt cleaning unit to the original position. Then tighten the screw on the fastener at two locations with the hex key (width: 6 mm).

	<p>Insert the belt cleaning unit straight in its original position. If it is inserted at an angle, the belt cleaning unit position sensor in the left rear will be unable to detect it, and therefore the emergency stop status may not be released.</p> <p style="text-align: center;">Belt cleaning unit position sensor</p> 
---	--

- 12 In Leonardo, open [Maintenance] and then select [Status flags] - [Complete washing]. Confirm the message displayed and click [Yes] to start belt cleaning. When belt cleaning is completed, the tower lamp changes from white to green. When belt cleaning is completed, perform [Complete washing] again, for a total of eight times.
- 13 Turn the left and right drain valves in the direction of the arrows to open them. The ink film remover in the cleaning tank is drained.

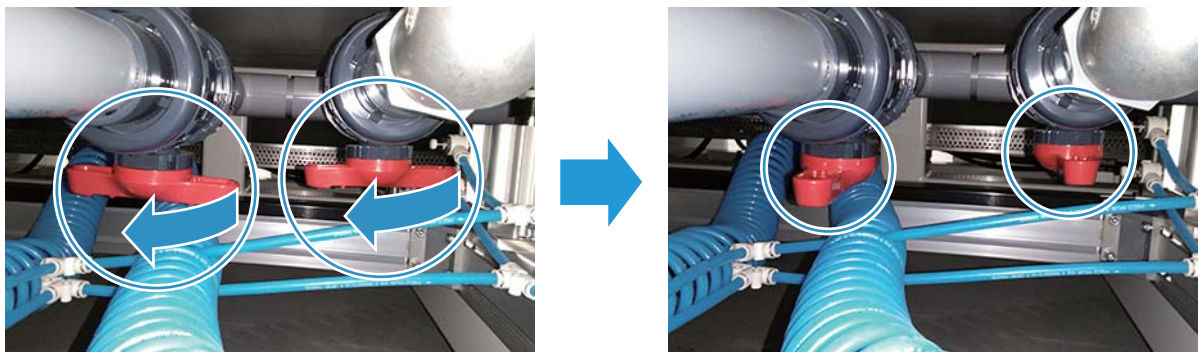

- 14** After all the ink film remover in the cleaning tank has been drained, turn the drain valve on the right side in the direction of the arrow to close it.

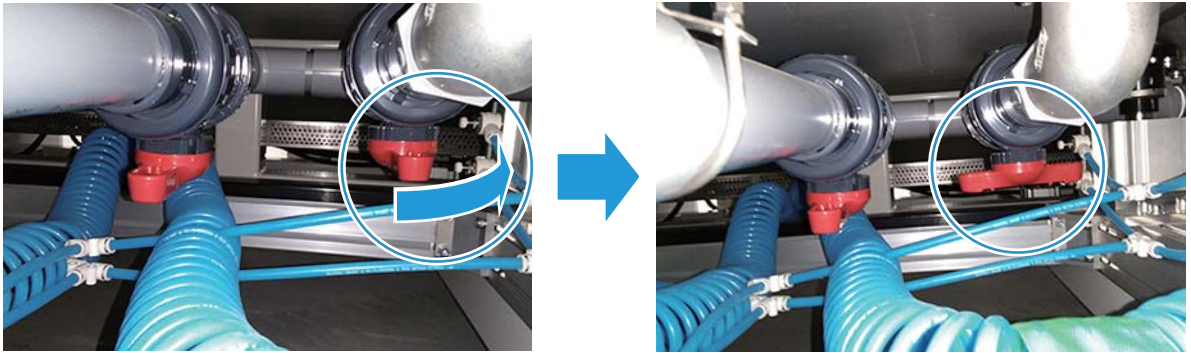

- 15** Remove the one screw of each fixing block [2] on the left and right using the hex key (width: 6 mm).



Store the removed screws to ensure they are not dropped or placed somewhere they can cause damage.

Right side

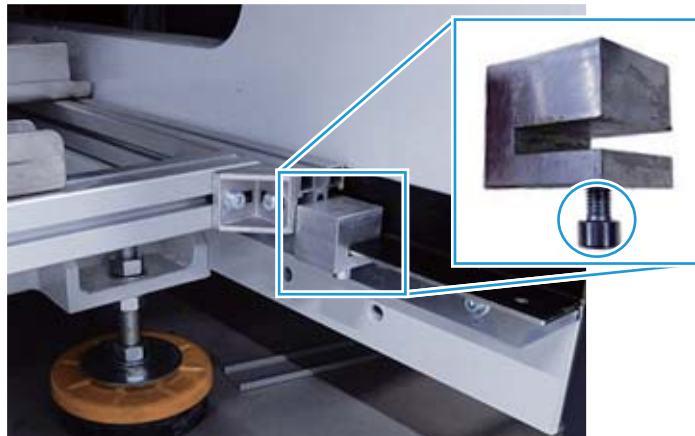

Left side



- 16** Pull the belt cleaning unit toward you until the carriage rail hits the stopper nearest from you.
- 17** Remove the sponge roller from the sponge roller tank and install it on the belt cleaning unit.
- 18** Use a bucket or the like to pour tap water into the tank on the bottom of the cleaning brushes.  
Fill water to the partition of the belt cleaning unit.

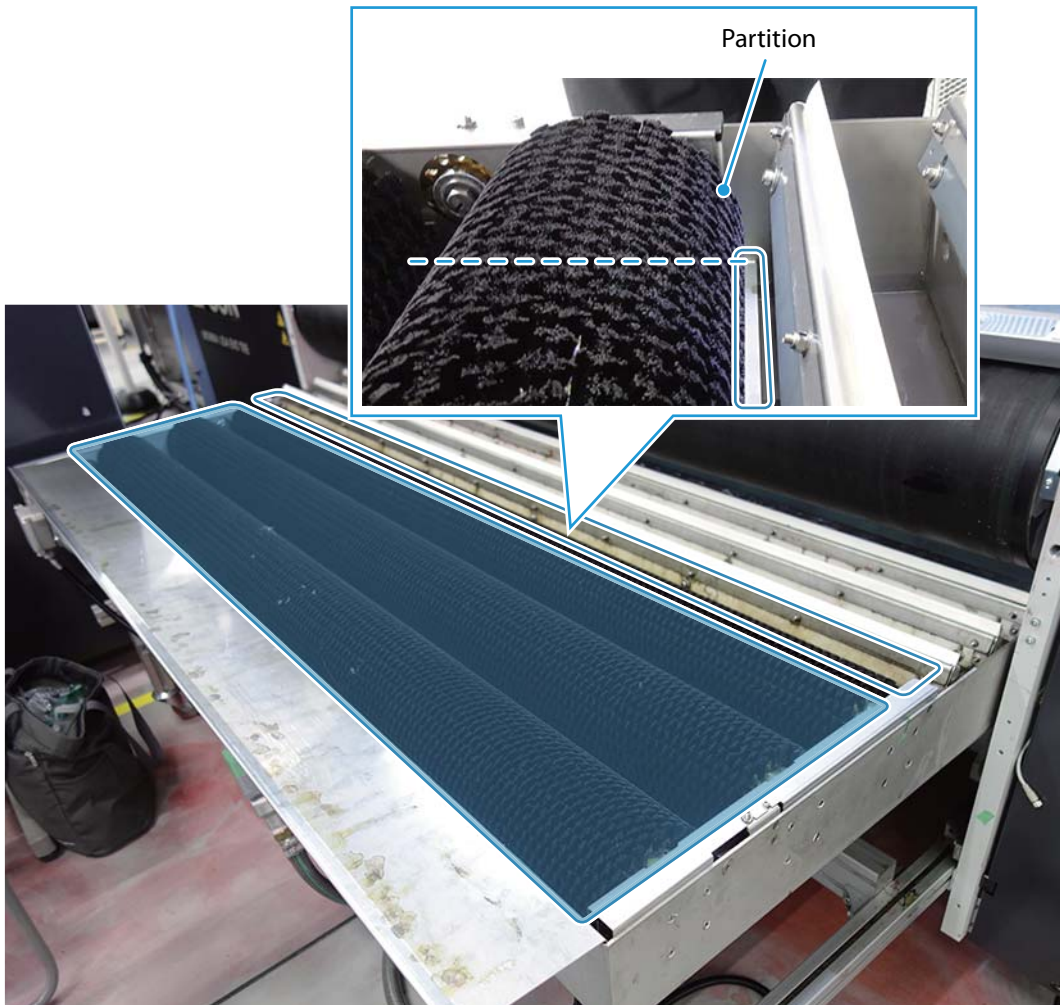

- 19** Return the belt cleaning unit to the carriage rail.

**20** Push the belt cleaning unit to the original position. Then tighten the screw on the fastener at two locations with the hex key (width: 6 mm).

	<p>Insert the belt cleaning unit straight in its original position. If it is inserted at an angle, the belt cleaning unit position sensor in the left rear will be unable to detect it, and therefore the emergency stop status may not be released.</p> <p>Belt cleaning unit position sensor</p> 
---	---

**21** Using a flat-head screwdriver, open the water supply valve.

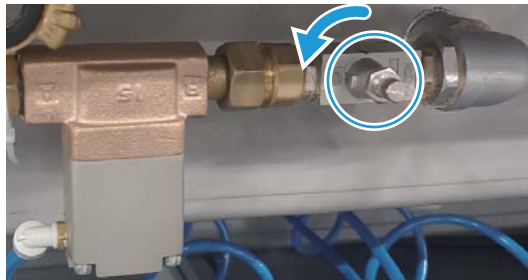

If the fabric attached to the belt floats even after removing the ink film, reapply glue. For more information, refer to ["Glue Re-Application"](#) on Page 145.

**ML-32000-180**

- 1** Put the ink film remover (approx. 7 L) and tap water (approx. 10 L) in the container and mix well.
- 2** Operate the lever to close the water supply valve.

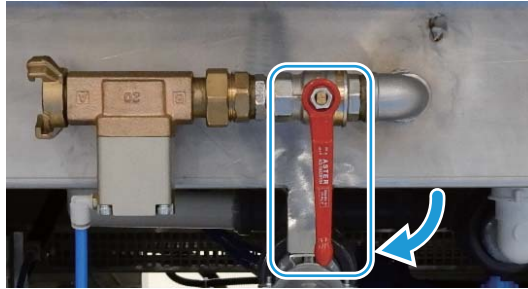

- 3** Check to see that water has filled up to the partition of the tank on the bottom of the cleaning brushes.

If there is not enough water accumulated, use a bucket or the like to pour in tap water.

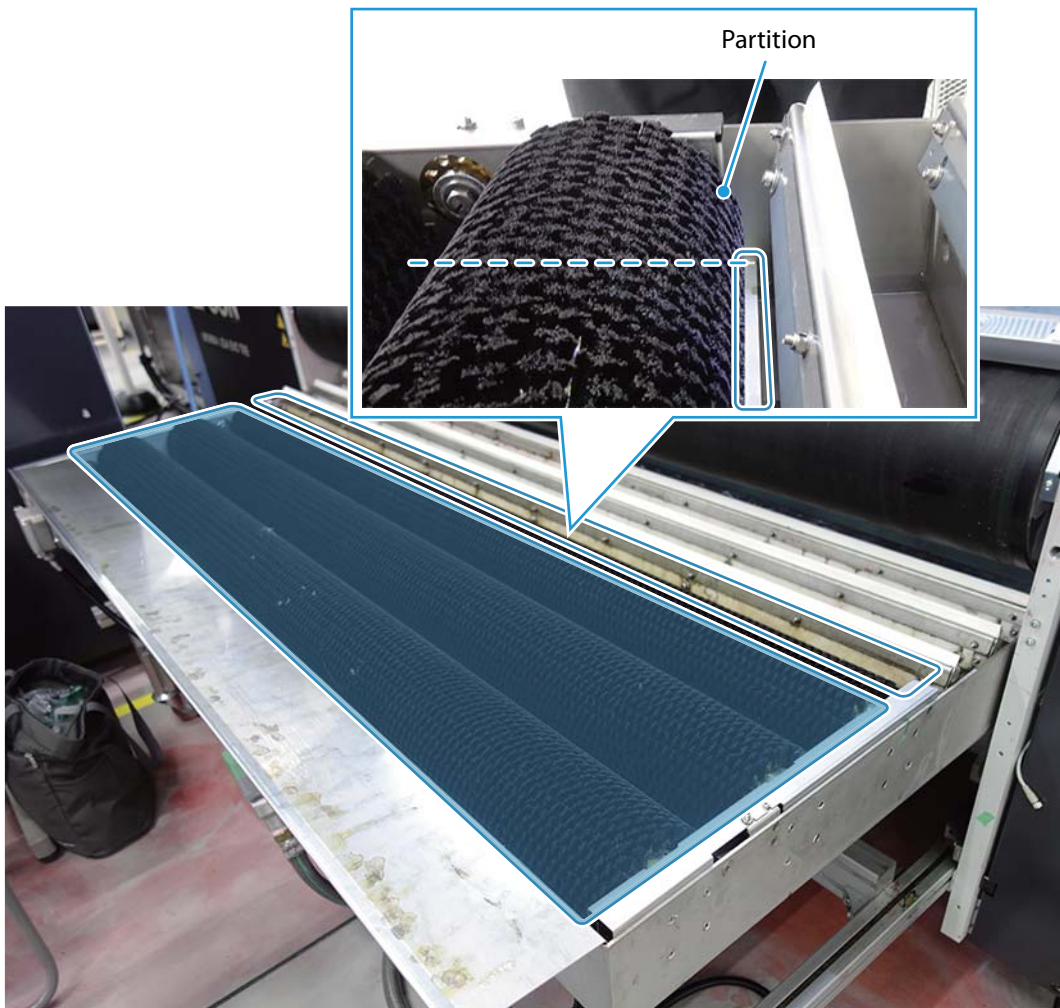

- 4** Check to see that no water remains in the tank at the bottom of the scraper.

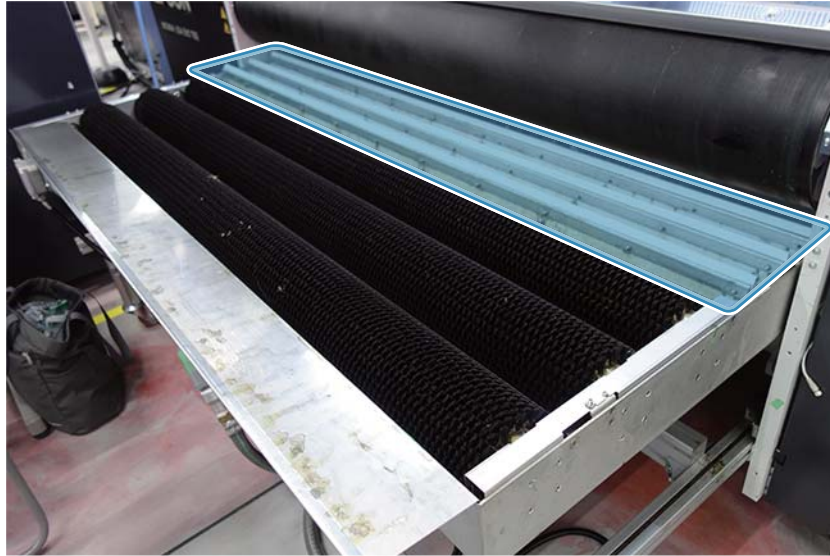

- 5** Turn the left drain valve in the direction of the arrow to close it.

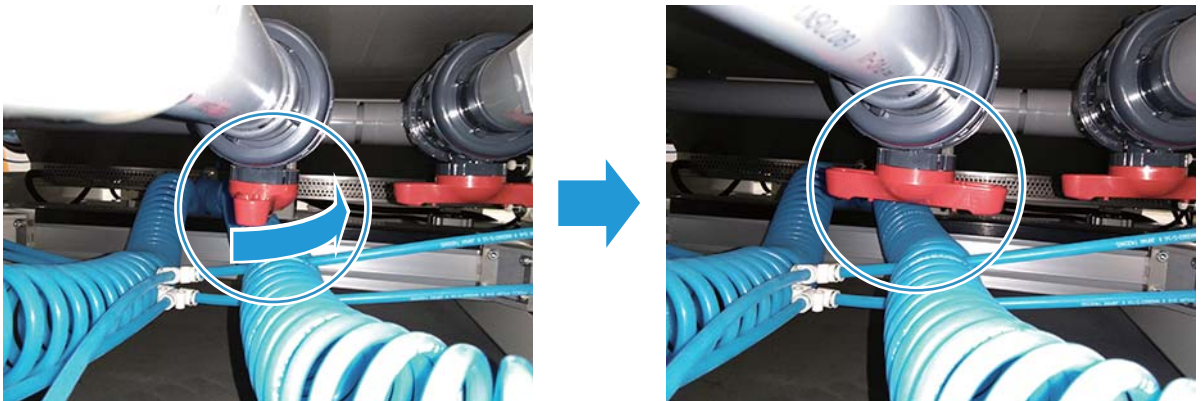

- 6** Pour the ink film remover made in step 1 into the tank on the bottom of the cleaning brushes.



- 7** Return the belt cleaning unit to the original position.
- 8** In Leonardo, open [Maintenance] and then select [Status flags] - [Complete washing]. Confirm the message displayed and click [Yes] to start belt cleaning. When belt cleaning is completed, the tower lamp changes from white to green. When belt cleaning is completed, perform [Complete washing] again, for a total of eight times.
- 9** Turn the left drain valve in the direction of the arrow to open it.  
The ink film remover in the cleaning tank is drained.

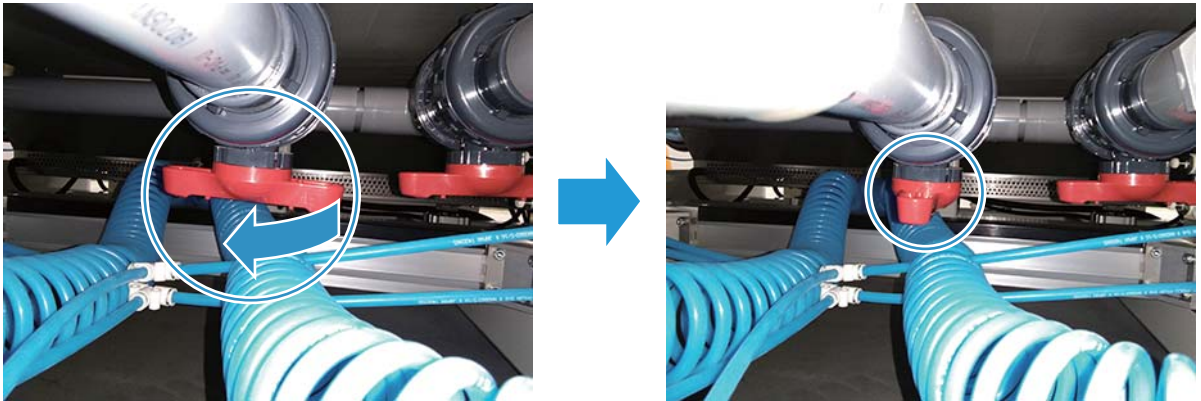

- 10** Operate the lever to open the water supply valve.

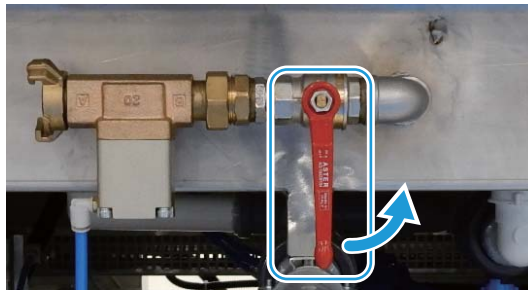

If the fabric attached to the belt floats even after removing the ink film, reapply glue. For more information, refer to "[Glue Re-Application](#)" on Page 145.

# Cleaning the Area around the Head and Inspecting the Ink Rack



The method for this procedure varies depending on the product in use.

When using the ML-32000-340 or ML-16000-180, refer to [“ML-32000-340 / ML-16000-180” on Page 64.](#)

## ML-32000-180

Implement this procedure when using the ML-32000-180.

Frequency	Every week/When a problem occurs, When a large amount of printing is completed
User Permissions	H
Personal Protective Equipment	Protective gloves and clothing, eye protection
Required Items	Cleaning stick, cleaning cloth, maintenance liquid plastic container, hex key (width: 4 mm), flashlight

 <b>CAUTION</b>	Be sure to wear eye protection. Failure to do so could cause ink to splash into the eyes.
	For cleaning, be sure to use the dedicated maintenance liquid.

- 1** Check that the machine is in the Printing Standby Status.  
(For more information, refer to [“Printing Standby Status” on Page 10.](#))
- 2** Press the emergency stop button.
- 3** Open the front cover.

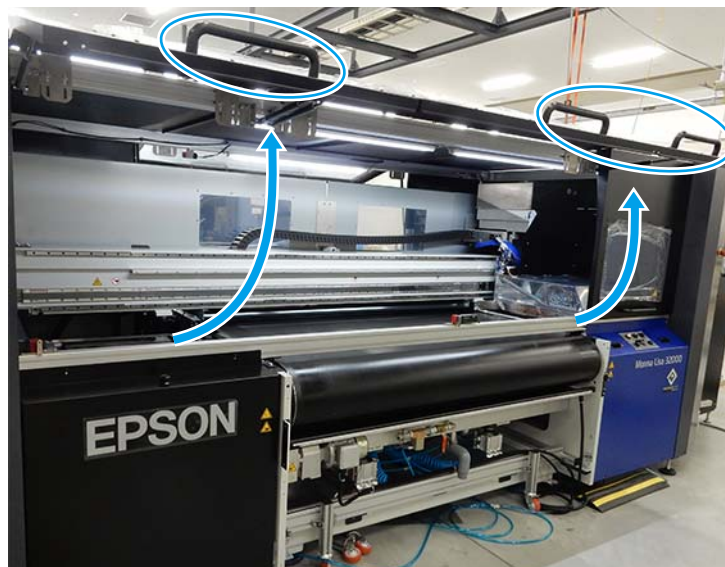

- 4** Pull the knurled screw on the front right side of the flushing plate, and turn it clockwise until you hear a click.

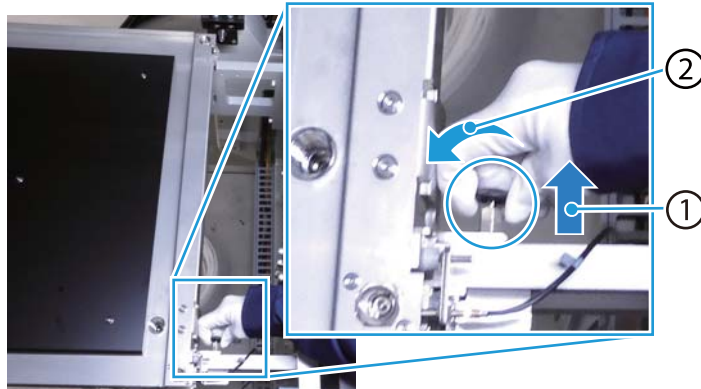

- 5** Move the flushing plate to the left.

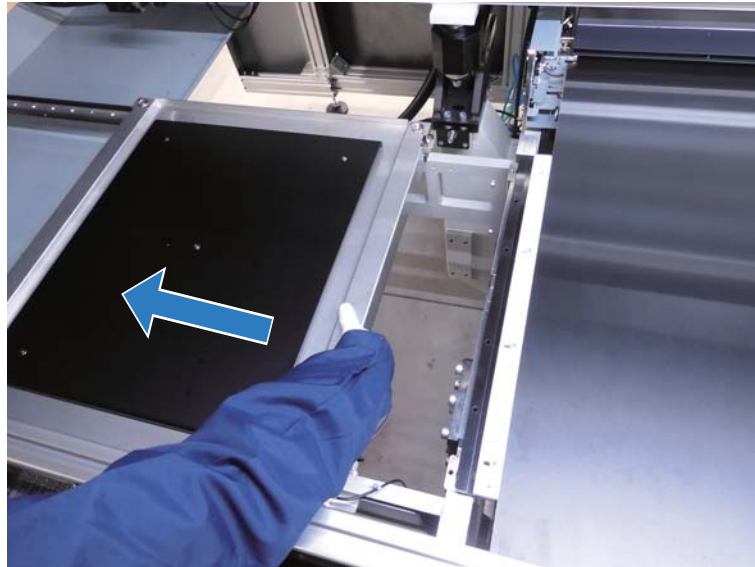

- 6** Close the front cover.
- 7** Release the emergency stop button.
- 8** Execute Set point.  
On the Leonardo operation screen, click [Setpoint] and then press the reset button on the main electric box. The print head carriage returns to the origin position and moves to the cleaning station.

- 9** Move the print head carriage to a position above the flushing plate.  
 On the Leonardo operation screen, open [Maintenance] (1), and click [+] (2) for [Carriage] under [Axes] once. When the head carriage moves to the center, click [+] again.

The carriage moves to the left, to a position above the flushing plate.

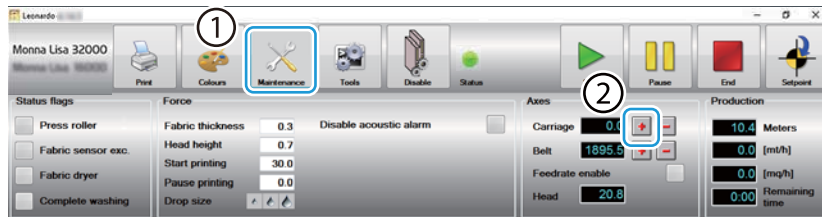

	<p>Do not work for a long period of time while the head carriage is uncapped. Doing so can cause the print head nozzles to clog, causing a printing error. Pigment ink in particular causes a failure if left uncapped for 24 hours.</p>
---	--



- 10** Press the emergency stop button.
- 11** Close the Leonardo screen and shut down the control PC.
- 12** Turn the main power switch to 0 (OFF) to turn the power off.
- 13** Remove the six screws from the side cover.



## 14 Lift the side cover handle and remove the cover.

 <p><b>CAUTION</b></p>	<p>When removing the side cover, be careful not to damage the interlock key in the upper center of the back of the cover. If this key is not inserted, this machine will not operate.</p> <p style="text-align: center;">Interlock key</p> 
---	---

## 15 Grab the handle on the ink rack with both hands, and pull it out from the ink rack housing.

	<p>Be careful of the following so as not to damage the cables:</p> <ul style="list-style-type: none"> <li>• Do not allow the ink rack wheels to run over the cables.</li> <li>• Do not pull the cables hard or apply excessive force.</li> </ul>
---	--

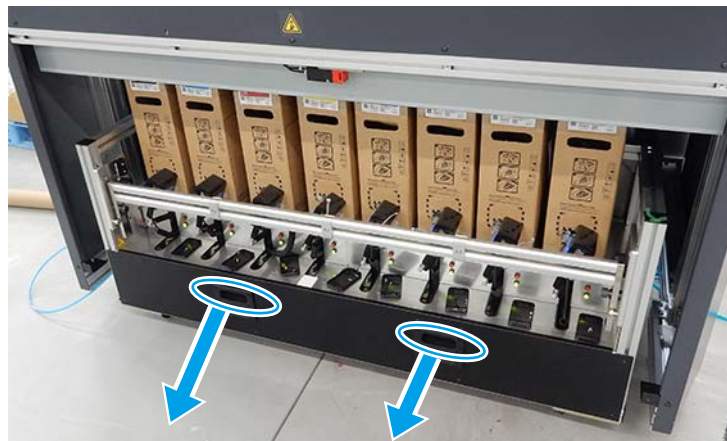

**16** Visually check for leaks in the ink path of the ink rack.

- Connections of the ink tubes on each ink path



- Ink pan of the ink rack

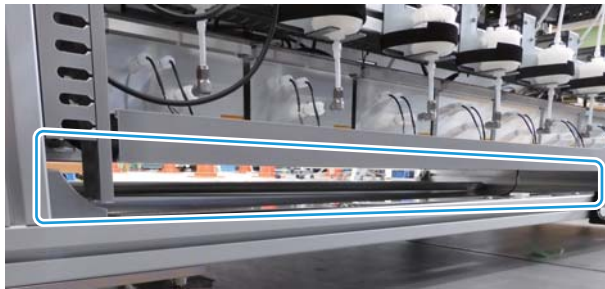





**17** Wear eye protection.

**18** Enter the ink rack housing with the following tools:  
Cleaning cloth, cleaning stick, a container of maintenance liquid, flashlight

<p><b>CAUTION</b></p>	<p>Make sure that the machine's power is off before entering the ink rack housing.</p>
-----------------------	--

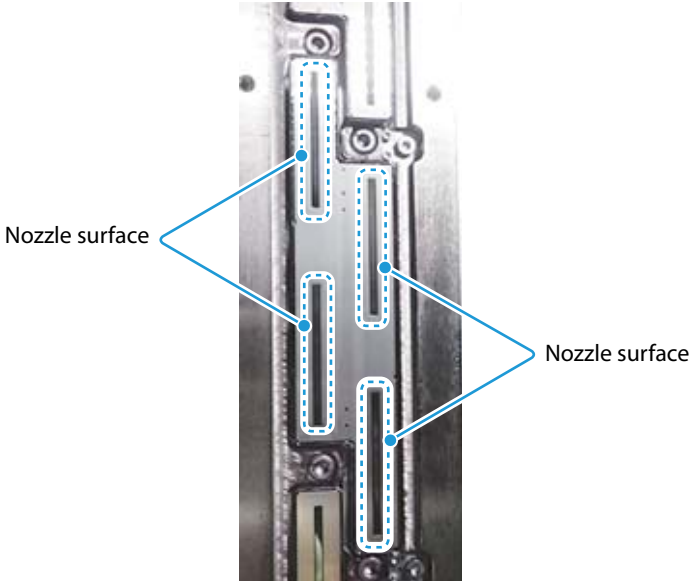
**19** While shining the flashlight at your hands, wipe off fluffy dust from the head front and ink stains on the head side face using the cleaning stick.

 <p><b>CAUTION</b></p>	<p>Observe the following precautions when cleaning the caps, wipers, and heads. Otherwise, the heads could fail. If these precautions are not observed, repair fees will be charged even during the warranty period.</p> <ul style="list-style-type: none"> <li>• Do not use tap water.</li> <li>• Use only a cleaning stick and cleaning cloth when cleaning these parts.</li> </ul>
	<p>Be careful not to touch the nozzle surface of the head or wipe it with the cleaning stick. Touching the nozzle surface may cause a printing error.</p> 
	<p>Completely wipe off ink-stained fiber or similar dust. Printing with such dust remaining on the parts may cause ink to drip on the fabric, resulting in a printing error.</p>



**20** When cleaning is finished, exit the ink rack housing and return the ink rack to the original position.

- 21** Attach the side cover.  
Place the protrusions on the lower left and right sides of the side cover on the guide of the machine, and insert the key of the side cover into the interlock.

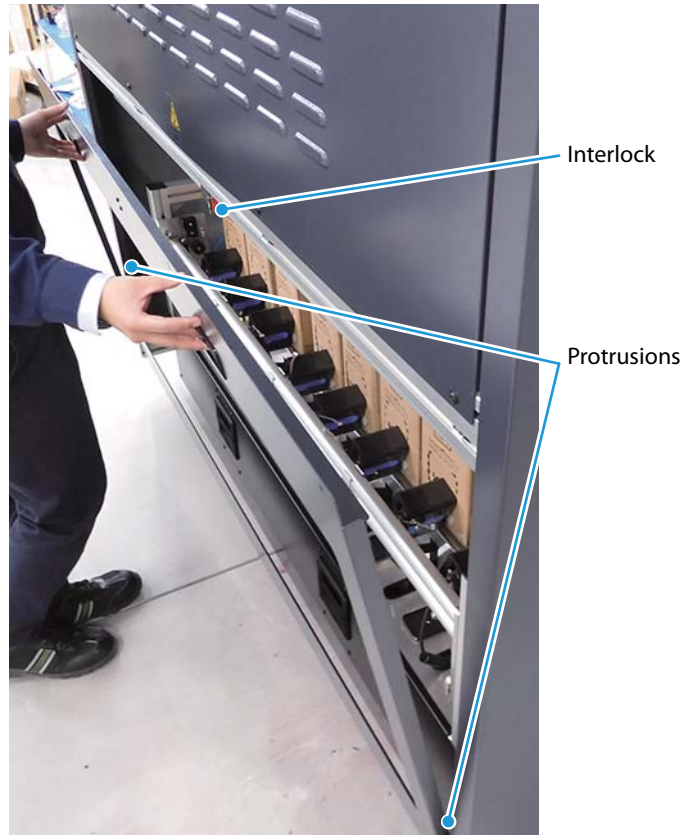

- 22** Tighten the six screws on the side cover.

- 23** Open the front cover on the left side.



**24** Push the print head carriage by hand to a position above the belt.

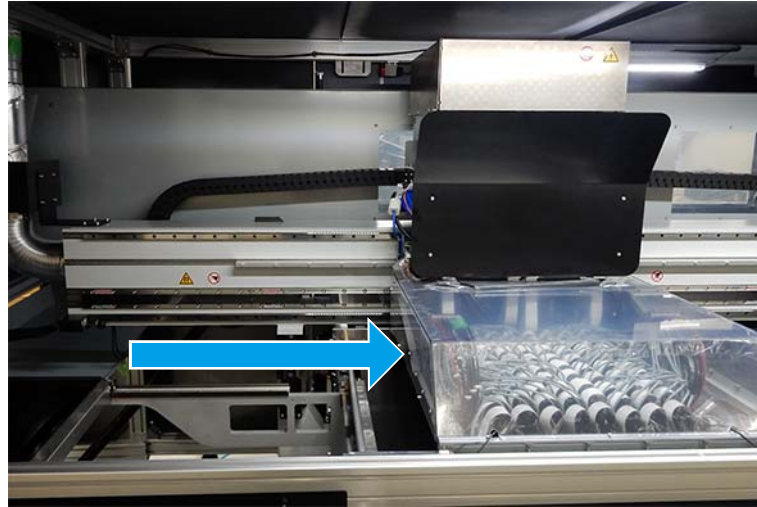

After moving the print head carriage to the outside, be sure to return it to the inside. If it is not returned to the inside, the sensor on the carriage may activate, and you may not be able to execute Setpoint.

**25** Move the flushing plate to the right side. Confirm that the knurled screw clicks and returns to the front.

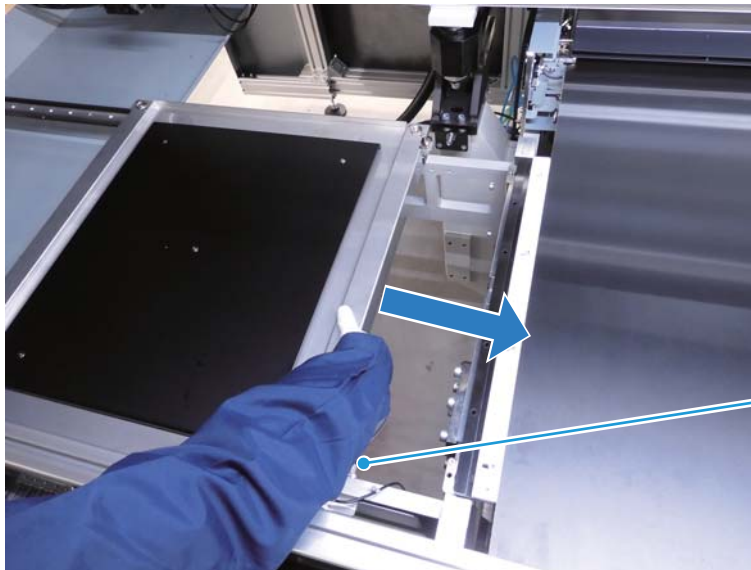

Knurled screw

**26** Close the front cover.

**27** Turn the main power switch to 1 (ON) to turn the power on.

**28** Start up Leonardo.

**29** Release the emergency stop button.



- 30** Execute Set point.  
On the Leonardo operation screen, click [Setpoint] and then press the reset button on the main electric box.
- 31** From [Maintenance] menu of Leonardo, execute head cleaning.  
Refer to the "Operation Guide" for the corresponding procedures.
- 32** Perform a nozzle check.  
Refer to the "Operation Guide" for the corresponding procedures.

This completes the work.

**ML-32000-340 / ML-16000-180**

Implement this section when using the ML-32000-340 or ML-16000-180.

Frequency	Every week/When a problem occurs, When a large amount of printing is completed
User Permissions	H
Personal Protective Equipment	Protective gloves and clothing, eye protection
Required Items	Cleaning stick, cleaning cloth, maintenance liquid, plastic container, antistatic wrist strap, flashlight

 <b>CAUTION</b>	Be sure to wear eye protection. Failure to do so could cause ink to splash into the eyes.
	Do not use normal tap water. Be sure to use the specified cleaning stick and cleaning cloth.

- 1** Check that the machine is in the **Printing Standby Status**.  
(For more information, refer to ["Printing Standby Status" on Page 10.](#))
- 2** Press the emergency stop button.
- 3** Open the front cover.



- 4 Turn the fixing screws on the left side of the flushing plate counterclockwise to loosen them.

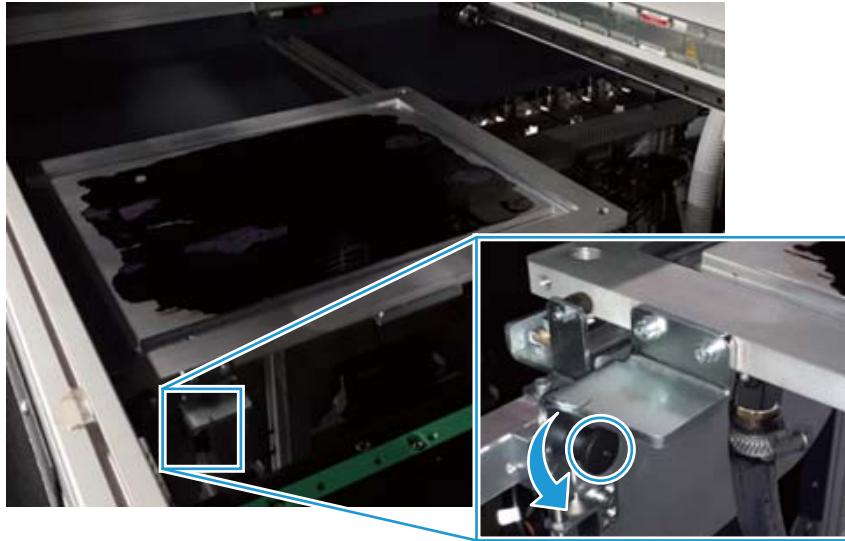

- 5 Move the flushing plate to the left.

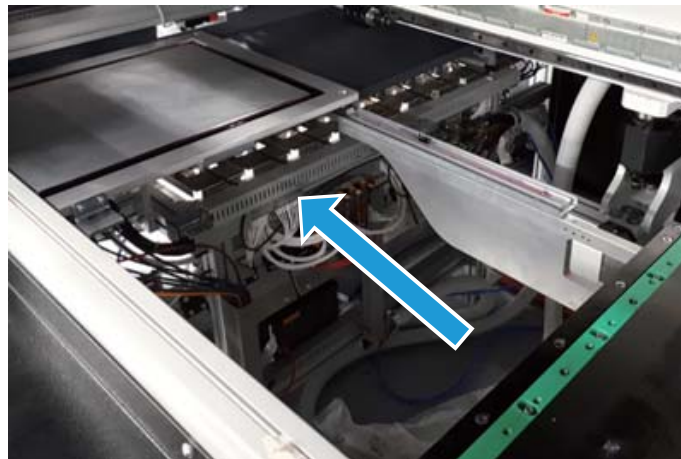

- 6 Close the front covers.
- 7 Release the emergency stop button.
- 8 Execute Setpoint.  
On the Leonardo operation screen, click [Setpoint] and then press the reset button on the main electric panel. The head carriage returns to the origin position and moves to the cleaning station.

**9 Move the head carriage to the flushing plate.**

On the Leonardo operation screen, open [Maintenance] (1), and click [+] (2) for [Carriage] under [Axes] once. When the head carriage moves to the center, click [+] again.

The head carriage moves to the left into the flushing area.

	<p>Do not work for a long period of time while the head carriage is uncapped. Doing so can cause the print head nozzles to clog, causing a printing error. Pigment ink in particular causes a failure if left uncapped for 24 hours.</p>
---	--

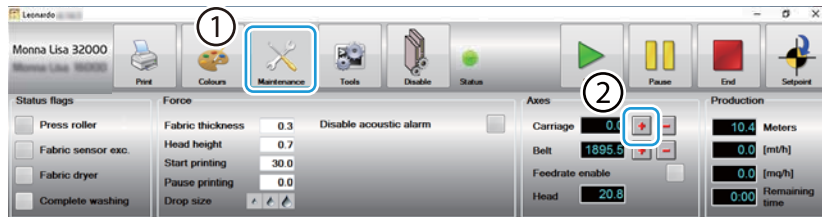

**10 Press the emergency stop button.**

**11 Close the Leonardo screen and shut down the control PC.**

**12 Turn the main power switch to 0 (OFF) to turn the power off.**

**13 Hold the parts on the ink rack as indicated by circles below with both hands, and pull it out from the ink rack housing until stopped by the stoppers.**

For the 10 L ink cartridge model, proceed to step 17. Steps 15 and 16 are not applicable.

	<p>Be careful of the following so as not to damage the cables:</p> <ul style="list-style-type: none"> <li>• Do not allow the ink rack wheels to run over the cables.</li> <li>• Do not pull the cables hard or apply excessive force.</li> </ul>
---	--



**14** Visually check for leaks in the ink path of the ink rack.

- Connections of the ink tubes on each ink path



- Ink pan of the ink rack



**15** Open the front left cover.

Remove the two screws from the cover.



**16** Remove the cover.

**17** Wear eye protection and antistatic wrist strap.





**18** Enter the ink rack housing with the following tools:  
 Cleaning cloth, cleaning stick, a container of maintenance liquid, flashlight.

 **CAUTION**

Manufacturer does not under any circumstances require any access inside of the machine for maintenance. All operations can and must be carried out from the outside.

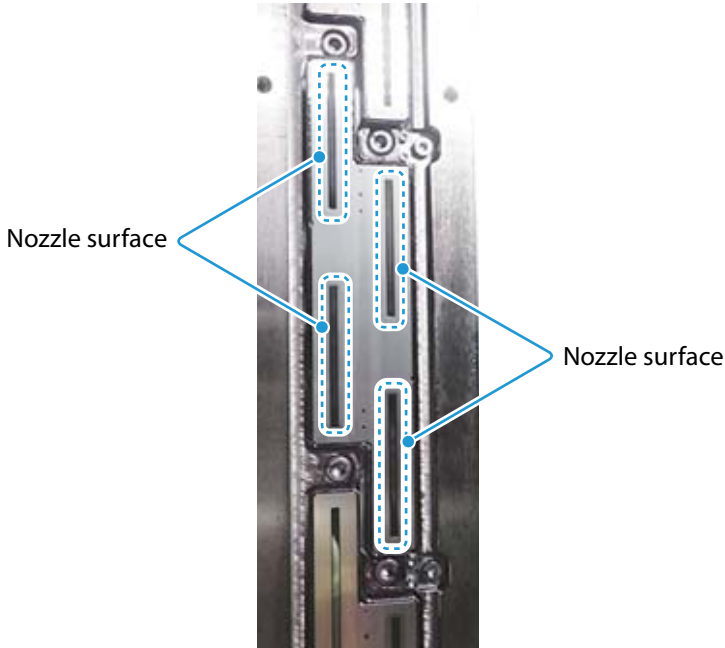

**19** While shining the flashlight at your hands, wipe off fluffy dust from the head front and ink stains on the head side face using the cleaning stick.

 <p><b>CAUTION</b></p> 	<p>Observe the following points when cleaning the caps, wipers, and heads. Failure to do so may cause a head fault.</p> <p>If these points are not observed, we will charge for repairs even during the warranty period.</p> <ul style="list-style-type: none"> <li>• Do not use normal tap water.</li> <li>• Do not use anything except for the cleaning stick and cleaning cloth.</li> </ul>
	<p>Be careful not to touch the nozzle surface of the head or wipe it with the cleaning stick. Touching the nozzle surface may cause a printing error.</p> 
	<p>Completely wipe off ink-stained fiber or similar dust. Printing with such dust remaining on the parts may cause ink to drip on the fabric, resulting in a printing error. Use a separate dry stick to remove any residual ink or cleaning liquid.</p>



- 20** When cleaning is finished, exit the ink rack housing.
- 21** Attach the front left cover.
- 22** Tighten the two screws of the cover.
- 23** Return the ink rack to the original position.
- 24** Turn the main power switch to 1 (ON) to turn the power on.
- 25** Start up Leonardo.
- 26** Release the emergency stop button.
- 27** Execute Setpoint.  
On the Leonardo operation screen, click [Setpoint] and then press the reset button on the main electric panel.
- 28** Press the emergency stop button.
- 29** Open the front covers of the flushing plate.

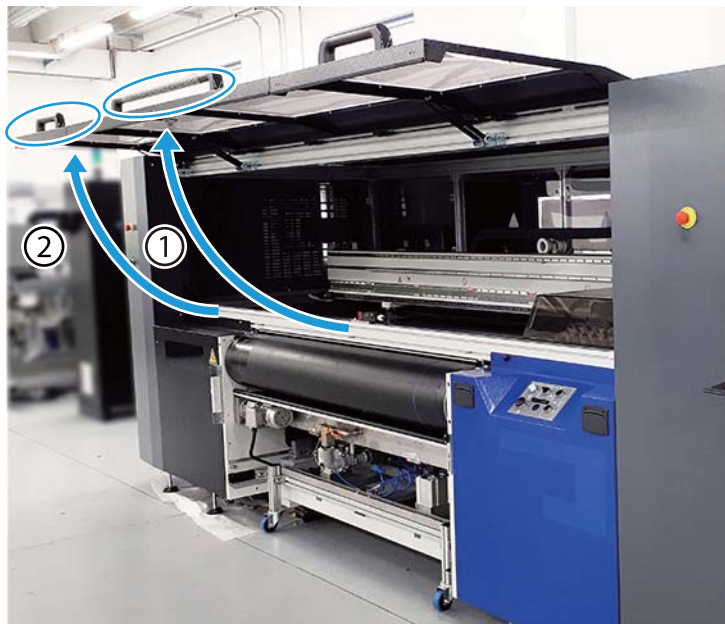

- 30** Return the flushing plate to the original position.  
Make sure the knurled screw clicks and the screw is locked.

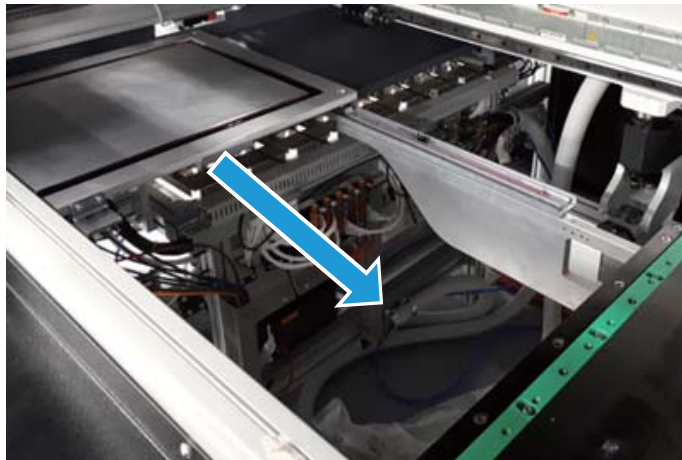

The location of the flushing plate is detected by sensor. Printing cannot be performed if it is not returned to the correct location.  
After moving the print head carriage to the outside, be sure to return it to the inside. If it is not returned to the inside, the sensor on the print head carriage may activate, and you may not be able to execute Setpoint.

- 31** Close the front covers.
- 32** Release the emergency stop button.
- 33** Execute Setpoint.  
On the Leonardo operation screen, click [Setpoint] and then press the reset button on the main electric panel. The head carriage returns to the origin position and moves to the cleaning station.
- 34** From [Maintenance] menu of Leonardo, execute head cleaning.  
Refer to the "Operation Guide" for the corresponding procedures.
- 35** Perform a nozzle check.  
Refer to the "Operation Guide" for the corresponding procedures.

This completes the work.

## Cleaning the Cleaning Brushes and the Area Around Them

Frequency	Every week/When necessary (After printing on fabric with fuzzy surface)
User Permissions	L
Personal Protective Equipment	Protective gloves and clothing
Required Items	Hex key (width: 6 mm)

- 1** Check that the machine is in the Power Off Status.  
(For more information, refer to "Power Off Status" on Page 10.)
- 2** Remove the screw from each fastener that secures the belt cleaning unit at two locations using the hex key (width: 6 mm).

	Carefully store all screws that have been removed, so that they are not dropped or placed somewhere where they could be damaged.
---	--

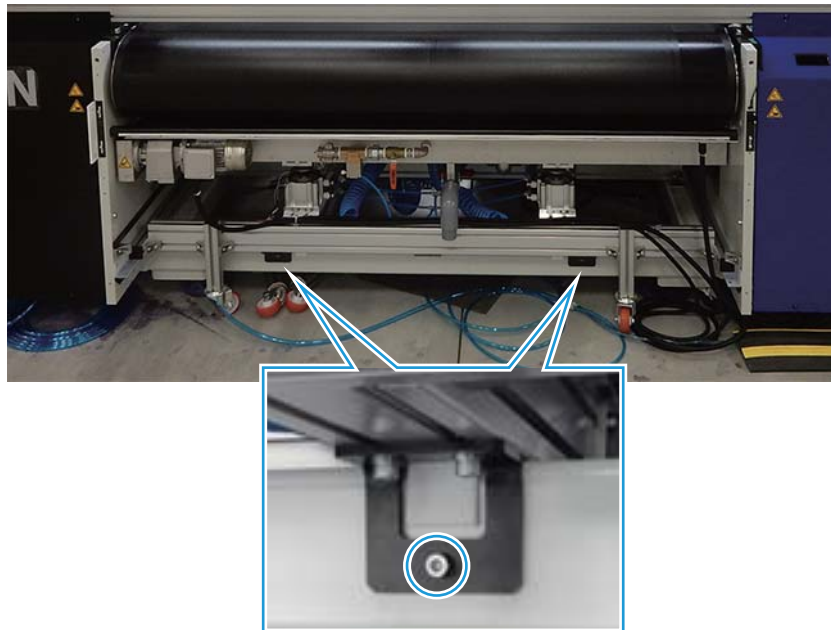

**3** Pull out the belt cleaning unit toward you.



When you pull out the belt cleaning unit, an emergency stop occurs.

**4** Remove all fiber and other dust from the cleaning brushes.

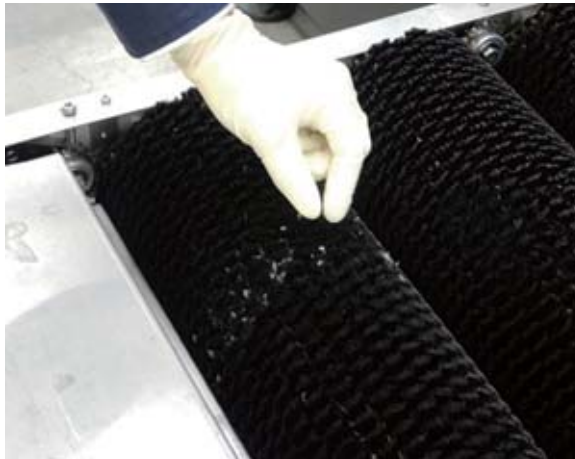

For the cleaning brushes, a metallic brush as shown below can also be used.



## 5 When cleaning is finished, put the belt cleaning unit back in the original position.



Insert the belt cleaning unit straight into its original position.

If it is inserted at an angle, the belt cleaning unit position sensor in the left rear will be unable to detect it, and therefore the emergency stop status may not be released.

Belt cleaning unit position sensor



## 6 Attach the two fasteners, and tighten the three screws of each using the hex key (width: 6 mm) to secure them.

This completes the work.

## Cleaning the Sponge Roller (ML-32000-340)

This section applies to ML-32000-340.

Frequency	Every week
User Permissions	L
Required Number of Workers	ML-16000-340: 3 persons ML-32000-240: 2 persons
Personal Protective Equipment	Eye protection, protective gloves and clothing
Required Items	Towel, Two belt cleaning unit wheels, Hex key (width: 6 mm)



 <b>CAUTION</b>	<p>Due to the weight of the belt cleaning unit, it should be pulled out and returned to its original position by the workers indicated above.</p> <p>Due to the weight of the sponge roller, it should be installed and removed by two workers.</p>
--	---

Before starting work, turn off the machine.

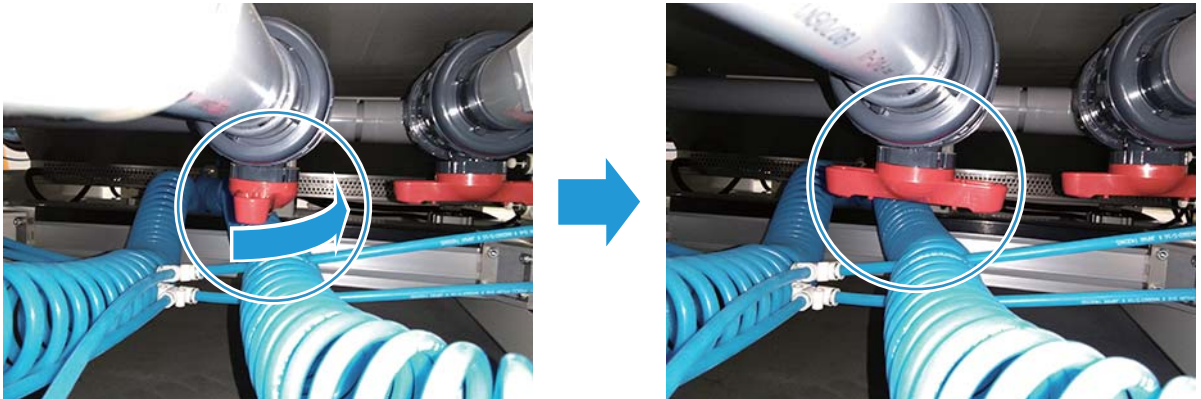
- 1 Turn the left drain valve in the direction of the arrow to close it.

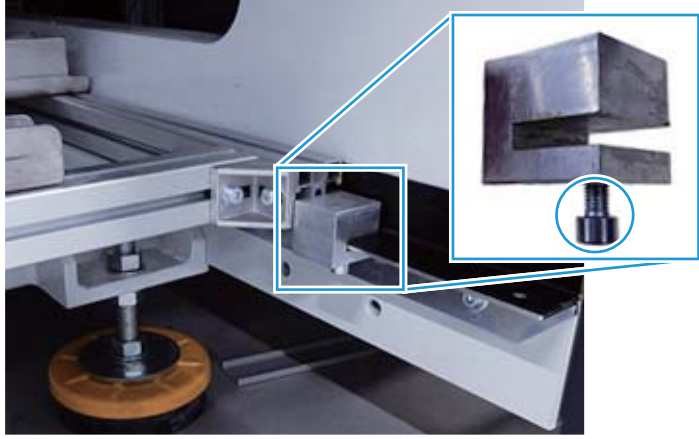

- 2** Remove the one screw of each fixing block [2] on the left and right using the hex key (width: 6 mm).

	<p>Store the removed screws to ensure they are not dropped or placed somewhere they can cause damage.</p> <p>Right side</p>  <p>Left side</p> 
---	---

- 3** Pull the belt cleaning unit toward you until the carriage rail hits the stopper nearest from you.





- 4** Fill the belt cleaning unit with tap water until the sponge roller is half submerged.

- 5 Lightly rub the sponge roller with your hands to remove any dirt. If the water becomes dirty, replace the tap water before continuing the work.

	<p>If the sponge is damaged, replace the sponge roller.</p>
---	---

- 6 After washing the sponge rollers, open the valve at the bottom of the belt cleaning unit, and then close the valve when draining is complete.
- 7 Wipe the sponge roller dry with a towel.
- 8 Return the belt cleaning unit to the carriage rail.
- 9 Push the belt cleaning unit to the original position. Then tighten the screw on the fastener at two locations with the hex key (width: 6 mm).

	<p>Insert the belt cleaning unit straight in its original position. If it is inserted at an angle, the belt cleaning unit position sensor in the left rear will be unable to detect it, and therefore the emergency stop status may not be released.</p> <p style="text-align: center;">Belt cleaning unit position sensor</p> 
---	---

- 10 Turn the left drain valve in the direction of the arrow to open it.

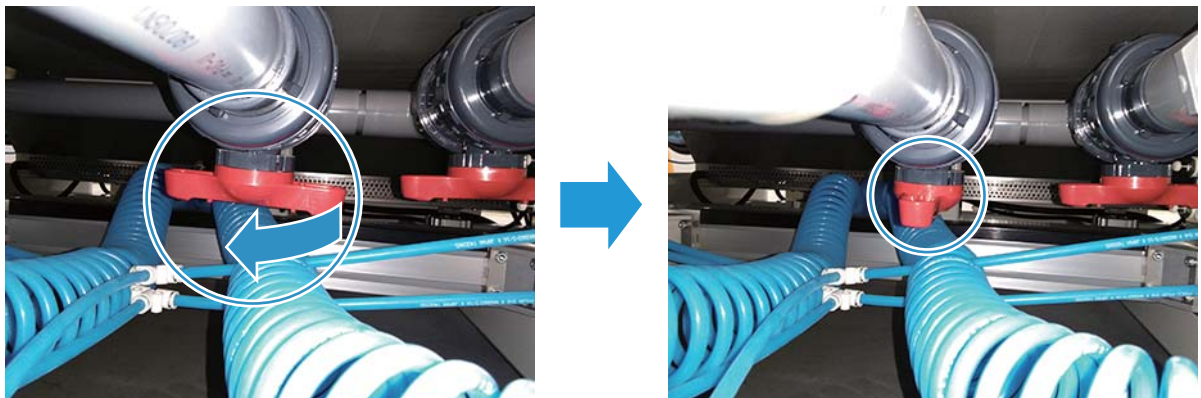

This completes the work.

## Cleaning the Head Cover

Frequency	When necessary
User Permissions	L
Personal Protective Equipment	Protective gloves and clothing
Required Items	Cleaning cloth, maintenance liquid, plastic container

	For cleaning, be sure to use the dedicated maintenance liquid.
---	--

- 1 Check that the machine is in the Power Off Status.**  
(For more information, refer to ["Power Off Status" on Page 10.](#))
- 2 Open the front cover.**
- 3 Moisten the cleaning cloth with maintenance liquid and wipe the head cover surface.**

	Completely wipe off ink-stained fiber or similar dust. Printing with such dust remaining on the parts may cause ink to drip on the fabric, resulting in a printing error.
---	---

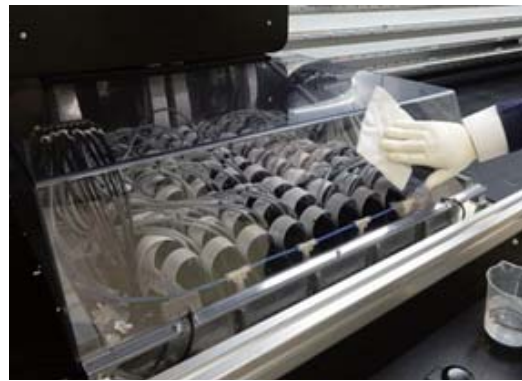
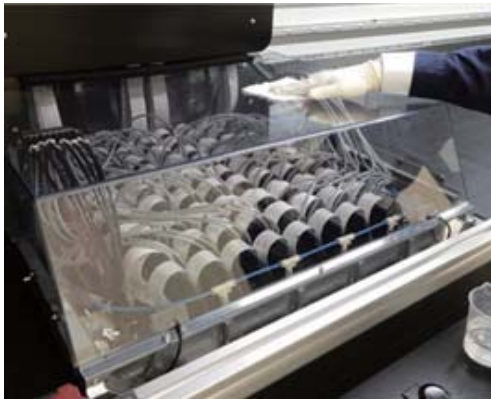

- 4 When cleaning is finished, close the front cover.**

This completes the work.

## Cleaning the Plate (Guide Beside the Belt)

Frequency	When necessary
User Permissions	L
Personal Protective Equipment	Protective gloves and clothing
Required Items	Cleaning cloth, maintenance liquid, plastic container

 <b>WARNING</b>	Workers should also pay attention to the edges of the plate and the screws in the groove, and keep them in proper condition.
--	--

If the plate (guide beside the belt) is stained by ink, wipe it off.

- 1** Check that the machine is in the Printing Standby Status.  
(For more information, refer to "Printing Standby Status" on Page 10.)
- 2** Move the print head carriage to a position above the flushing plate.  
On the Leonardo operation screen, open [Maintenance] (1), and click [+] (2) for [Carriage] under [Axes] once. The head carriage moves to the center, click [+] again. The carriage moves to the left, to a position above the flushing plate.

	Do not work for a long period of time while the head carriage is uncapped. Doing so can cause the print head nozzles to clog, causing a printing error. Pigment ink in particular causes a failure if left uncapped for 24 hours.
---	---



- 3** Press the emergency stop button.
- 4** Open the front cover.
- 5** Wipe off the right and left plates using the cleaning cloth moistened with maintenance liquid.





**6** When cleaning is finished, close the front cover.

This completes the work.

## Cleaning the Carriage Operating Parts on the Print Heads

Frequency	Every month
User Permissions	L
Personal Protective Equipment	Protective gloves and clothing
Required Items	Cleaning cloth

- 1** Check that the machine is in the Power Off Status.  
(For more information, refer to "Power Off Status" on Page 10.)
- 2** Open the front cover.
- 3** Clean the carriage rail with the cleaning cloth.

 <b>CAUTION</b>	Make sure that the machine's power is off before performing work.
	Never touch the linear scale or the magnet rail. Doing so may cause malfunction.



Wipe the carriage rail in two steps, on the left and on the right.





- 4 When cleaning is finished, close the front cover
- 5 Turn the main power switch to 1 (ON) to turn the power on.
- 6 Start up Leonardo.
- 7 Release the emergency stop button.
- 8 Execute Set point.  
On the Leonardo operation screen, click [Setpoint] and then press the reset button on the main electric box.
- 9 Move the print head carriage to a position above the flushing plate.  
On the Leonardo operation screen, open [Maintenance] (1), and click [+] (2) for [Carriage] under [Axes] once. When the head carriage moves to the center, click [+] again.  
The carriage moves to the left, to a position above the flushing plate.

	Do not work for a long period of time while the head carriage is uncapped. Doing so can cause the print head nozzles to clog, causing a printing error. Pigment ink in particular causes a failure if left uncapped for 24 hours.
--	---



- 10 Press the emergency stop button.
- 11 Close the Leonardo screen and shut down the control PC.
- 12 Turn the main power switch to 0 (OFF) to turn the power off.
- 13 Open the front cover.
- 14 Clean the carriage rail on the cleaning station side with the cleaning cloth.

 <b>CAUTION</b>	Make sure that the machine's power is off before performing work.
	Never touch the linear scale or the magnet rail. Doing so may cause malfunction.
	After moving the print head carriage to the outside, be sure to return it to the inside. If it is not returned to the inside, the sensor on the carriage may activate, and you may not be able to execute Setpoint.

- 15** When cleaning is finished, close the front cover.
- 16** Turn the main power switch to 1 (ON) to turn the power on.
- 17** Release the emergency stop button.
- 18** Start up Leonardo.
- 19** Execute Set point.  
On the Leonardo operation screen, click [Setpoint] and then press the reset button on the main electric box. The print head carriage moves to the cleaning station.

This completes the work.

# Adding Grease to the Scan Spindle

The method for this procedure varies depending on the product in use.

When using the ML-32000-340 or ML-16000-180, refer to [“ML-32000-340 / ML-16000-180” on Page 94](#).

## ML-32000-180

Implement this procedure when using the ML-32000-180.

Frequency	Every six months
User Permissions	H
Personal Protective Equipment	Protective gloves and clothing
Required Items	Scan spindle grease, grease pump, cleaning cloths, flashlight

Add grease to the scan spindle.

- 1** Check that the machine is in the Printing Standby Status.  
(For more information, refer to [“Printing Standby Status” on Page 10](#).)
- 2** Open the front cover on the flushing plate side.



- 3 Pull the knurled screw on the front right side of the flushing plate, and turn it clockwise until you hear a click.

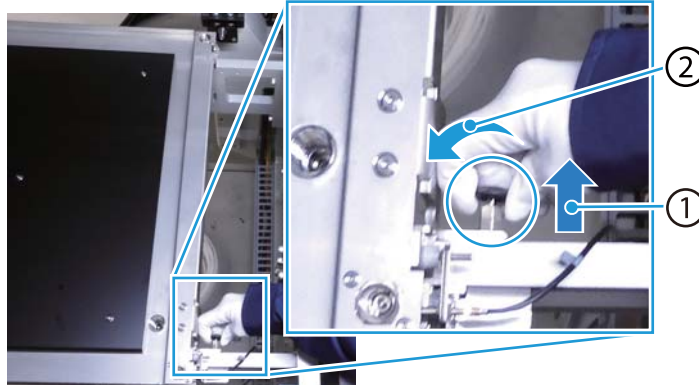

- 4 Move the flushing plate to the left.

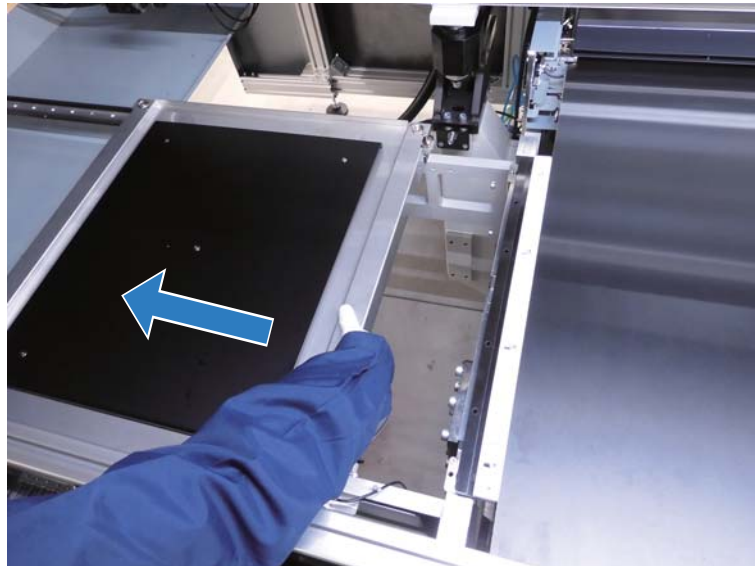

- 5 Close the front cover.

- 6 Move the print head carriage to a position above the flushing plate. On the Leonardo operation screen, open [Maintenance] (1), and click [+] (2) for [Carriage] under [Axes] once. When the head carriage moves to the center, click [+] again. The carriage moves to the left, to a position above the flushing plate.



Do not work for a long period of time while the head carriage is uncapped. Doing so can cause the print head nozzles to clog, causing a printing error. Pigment ink in particular causes a failure if left uncapped for 24 hours.



- 7 Press the emergency stop button.
- 8 Close the Leonardo screen and shut down the control PC.
- 9 Turn the main power switch to 0 (OFF) to turn the power off.
- 10 Open the front cover on the flushing plate side.
- 11 Remove the six screws from the side cover.



- 12 Lift the side cover handle and remove the cover.



**CAUTION**

When removing the side cover, be careful not to damage the interlock key in the upper center of the back of the cover. If this key is not inserted, this machine will not operate.

Interlock key



**13** Grab the handle on the ink rack with both hands, and pull it out from the ink rack housing.

	<p>Be careful of the following so as not to damage the cables:</p> <ul style="list-style-type: none"> <li>• Do not allow the ink rack wheels to run over the cables.</li> <li>• Do not pull the cables hard or apply excessive force.</li> </ul>
--	--

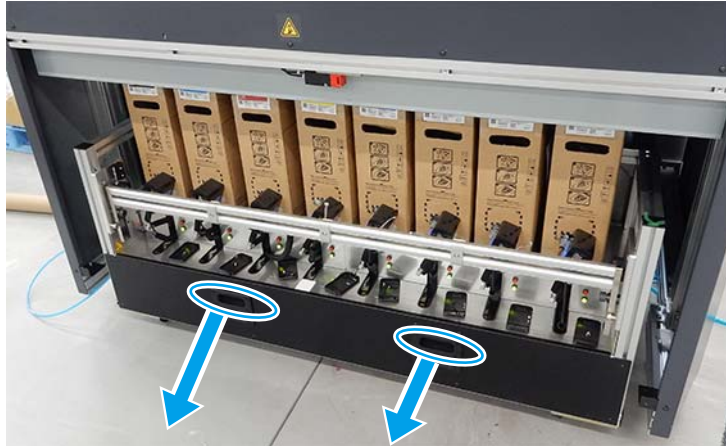

**14** Enter the ink rack housing with the following tools:  
Grease pump loaded with scan spindle grease, cleaning cloths, flashlight

<p><b>CAUTION</b></p>	<p>Make sure that the machine's power is off before entering the ink rack housing.</p>
-----------------------	--

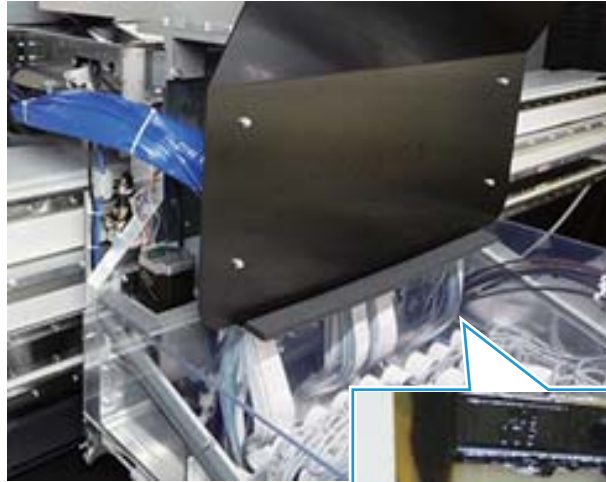

- 15** Use the flashlight to light the area around your hands while adding grease from under the print head carriage to the oil filler hole (lower) of the linear block on the right side of the scan spindle.

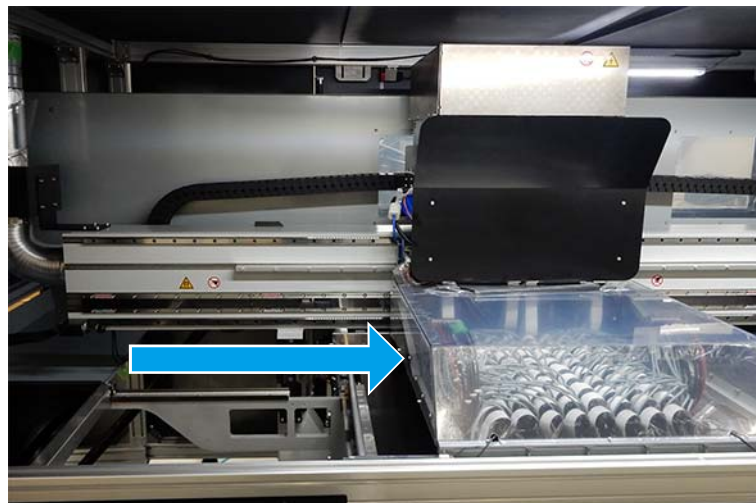

- 16** Push the print head carriage by hand to a position above the belt.



**17** Add grease using the grease pump through the two oil filler holes (upper and lower holes) of the linear block on the left side of the scan spindle.  
 Use cleaning cloths to wipe off any excess grease or ink adhering to the oil filler holes and surrounding area before working.



	<p>The proper grease amount is 1 to 3 g for each oil filler hole.                  Stop adding grease if it starts to come out from the edges of the slide.</p>
	<p>Do not add too much grease. Doing so can result in excess grease dripping onto fabric, resulting in a printing error.</p>



**18** Exit the ink rack housing.

**19** Push the print head carriage by hand to a position above the flushing plate.

**20** Add grease from the front of the machine to the oil filler hole (upper) of the linear block on the right side of the scan spindle.

	<p>Never touch the linear scale or the magnet rail. Doing so may cause malfunction.</p>
	<ul style="list-style-type: none"> <li>• Use a step stool when working.</li> <li>• Be careful that body parts, protective clothing, tools, and other items do not contact the belt.</li> </ul> <p>Contact with the belt may result in glue peeling off from the belt surface or being damaged.</p>

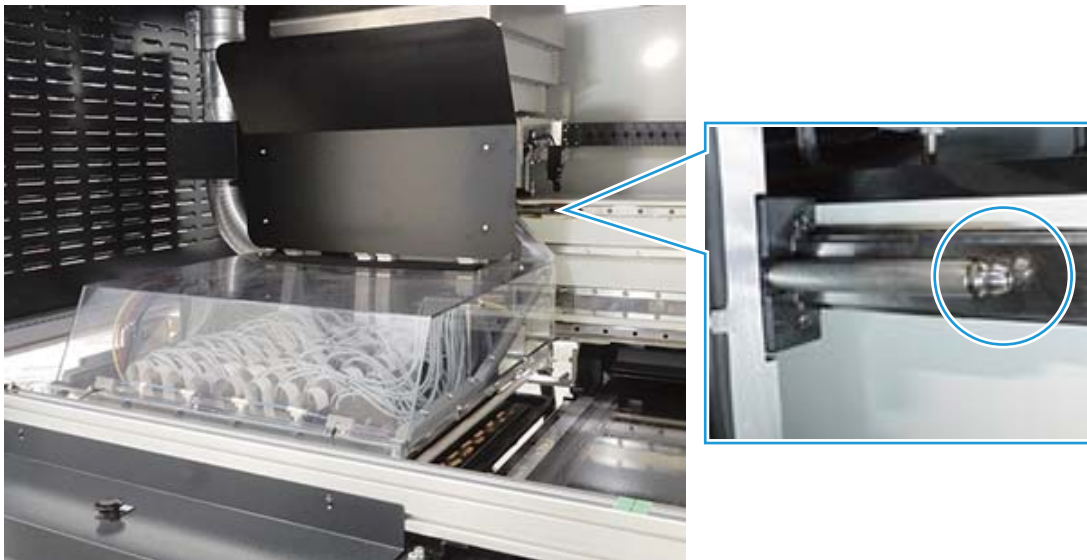

**21** Return the ink rack to the original position

- 22** Attach the side cover. Place the protrusions on the lower left and right sides of the side cover on the guide of the machine, and insert the key of the side cover into the interlock.

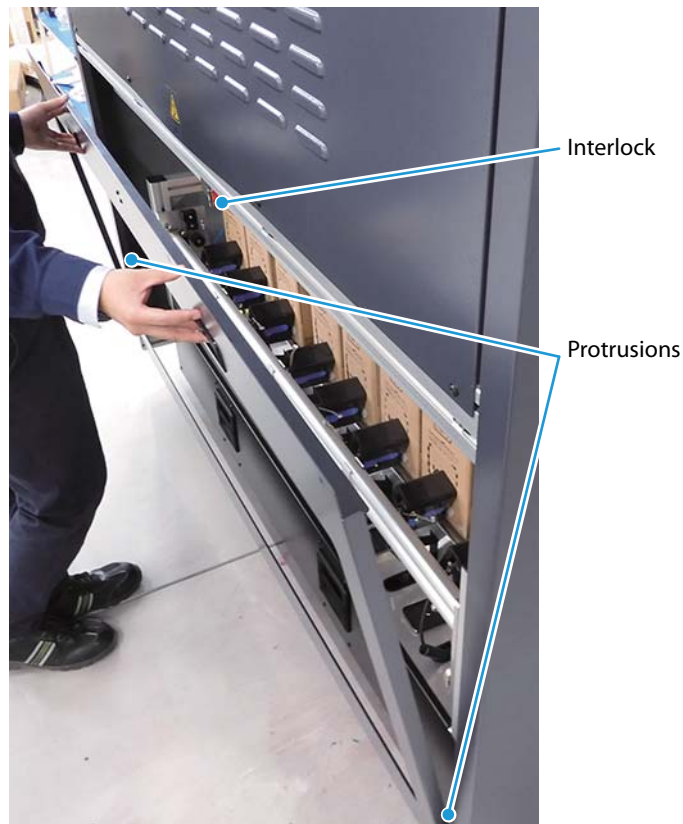

- 23** Tighten the six screws on the side cover.

- 24** Push the print head carriage by hand to a position above the belt.

- 25** Move the flushing plate to the right side. Confirm that the knurled screw clicks and returns to the front.

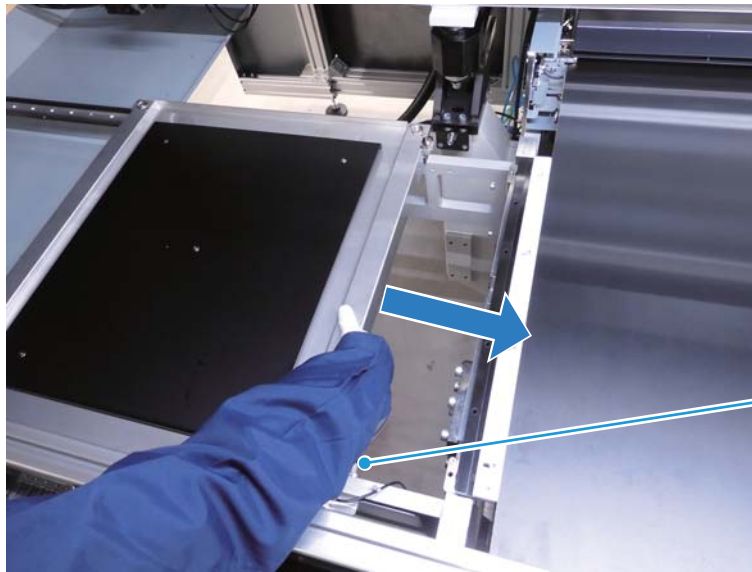
**CAUTION**

After moving the print head carriage to the outside, be sure to return it to the inside. If it is not returned to the inside, the sensor on the carriage may activate, and you may not be able to execute Setpoint.

- 26** Close the front cover.
- 27** Turn the main power switch to 1 (ON) to turn the power on.
- 28** Start up Leonardo.
- 29** Release the emergency stop button.
- 30** Execute Set point.  
On the Leonardo operation screen, click [Setpoint] and then press the reset button on the main electric box. The print head carriage returns to the origin position and moves to the cleaning station.
- 31** On the Leonardo operation screen, specify the length under [Print] and select the [Colours exclusion] check box under [Colours]. Then move the print head carriage back and forth five times to spread the grease across the entire surface.
- 32** Refer to procedures 2 to 14 to perform the following procedures.
- Move the flushing plate.
  - Move the head carriage on the print head.
  - Turn off the power to the machine.
  - Pull out the ink rack, and enter the ink rack housing.

**33** From under the print head carriage, check the oil filler hole (lower) of the linear block on the right side of the scan spindle and use cleaning cloths to wipe off any excess grease.

**34** Push the print head carriage by hand to a position above the belt.



**35** Check the two oil filler holes (upper and lower holes) of the linear block on the left side of the scan spindle, and use cleaning cloths to wipe off any excess grease.

**36** Push the head carriage on the print head by hand to a position above the flushing plate.

	Do not work for a long period of time while the head carriage is uncapped. Doing so can cause the print head nozzles to clog, causing a printing error. Pigment ink in particular causes a failure if left uncapped for 24 hours.
---	---

**37** Exit the ink rack housing.

**38** From the front of the machine, check the oil filler hole (upper) of the linear block on the right side of the scan spindle and use cleaning cloths to wipe off any excess grease.

	Never touch the linear scale or the magnet rail. Doing so may cause malfunction.
	<ul style="list-style-type: none"> <li>• Use a step stool when working.</li> <li>• Be careful that body parts, protective clothing, tools, and other items do not contact the belt.</li> </ul> <p>Contact with the belt may result in glue peeling off from the belt surface or being damaged.</p>

**39** Return the ink rack to the original position, and attach the side cover.

**40** Push the print head carriage by hand to a position above the belt.

**41** Move the flushing plate to the right side. Confirm that the knurled screw clicks and returns to the front.

 <b>CAUTION</b>	After moving the print head carriage to the outside, be sure to return it to the inside. If it is not returned to the inside, the sensor on the carriage may activate, and you may not be able to execute Setpoint.
--	---

**42** Close the front cover.

**43** Refer to procedures 27 to 30 to turn on the power and execute Setpoint.

This completes the work.

**ML-32000-340 / ML-16000-180**

Implement this section when using the ML-32000-340 or ML-16000-180.

Frequency	Every six months
User Permissions	H
Personal Protective Equipment	Protective gloves and clothing
Required Items	Scan spindle grease, grease pump



- 1 Check that the machine is in the Printing Standby Status.**  
(For more information, refer to ["Printing Standby Status" on Page 10.](#))
- 2 Move the print head carriage to a position above the flushing plate.**  
On the Leonardo operation screen, open [Maintenance] (1), and click [+] (2) for [Carriage] under [Axes] once. When the head carriage moves to the center, click [+] again. The carriage moves to the left, to a position above the flushing plate.

	Do not work for a long period of time while the head carriage is uncapped. Doing so can cause the print head nozzles to clog, causing a printing error. Pigment ink in particular causes a failure if left uncapped for 24 hours.
--	---



- 3 Press the emergency stop button.**
- 4 Close the Leonardo screen and shut down the control PC.**
- 5 Turn the main power switch to 0 (OFF) to turn the power off.**
- 6 Open the front covers.**
- 7 Clean the carriage rail with the cleaning cloth.**  
(For more information, refer to ["Cleaning the Carriage Operating Parts on the Print Heads" on Page 81.](#))

**8 Apply a proper amount of carriage grease with the grease pump to the top and bottom surfaces of the carriage rail cleaned in Procedure 7.**

	<p>Do not add too much grease. Doing so can result in excess grease dripping onto fabric, resulting in a printing error.</p>
	<p>The proper grease amount is 1 to 3 g for each oil filler hole. Stop adding grease if it starts to come out from the edges of the slide.</p>
	<p>Do not touch the carriage operating parts. Doing so may cause malfunction.</p>

Top surface



Bottom surface





- 9 When work is finished, close the front covers.
- 10 Turn the main power switch to 1 (ON) to turn the power on.
- 11 Start up Leonardo.
- 12 Release the emergency stop button.
- 13 Execute Setpoint.  
On the Leonardo operation screen, click [Setpoint] and then press the reset button on the main electric panel.
- 14 On the Leonardo operation screen, specify the length under [Print] and select the [Colours exclusion] check box under [Colours]. Then move the print head carriage back and forth five times to spread the grease across the entire surface.
- 15 Move the print head carriage to a position above the flushing plate.  
On the Leonardo operation screen, open [Maintenance] (1), and click [+] (2) for [Carriage] under [Axes] once. When the head carriage moves to the center, click [+] again. The carriage moves to the left, to a position above the flushing plate.

	<p>Do not work for a long period of time while the head carriage is uncapped. Doing so can cause the print head nozzles to clog, causing a printing error. Pigment ink in particular causes a failure if left uncapped for 24 hours.</p>
---	--



- 16 Release the emergency stop button.
- 17 Close the Leonardo screen and shut down the control PC.
- 18 Turn the main power switch to 0 (OFF) to turn the power off.
- 19 Open the front covers.

**20** Using the grease pump, add grease through the oil filler hole on the linear block on both sides of the scan spindle.

	<p>Do not add too much grease. Doing so can result in excess grease dripping onto fabric, resulting in a printing error.</p>
	<p>The proper grease amount is 1 to 3 g for each oil filler hole. Stop adding grease if it starts to come out from the edges of the slide.</p>

Right side

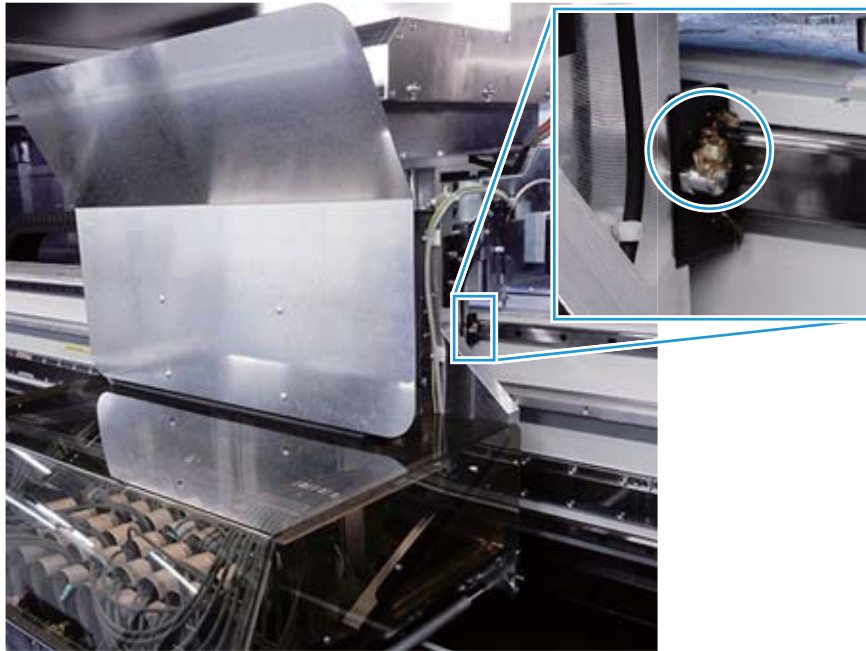

Left side

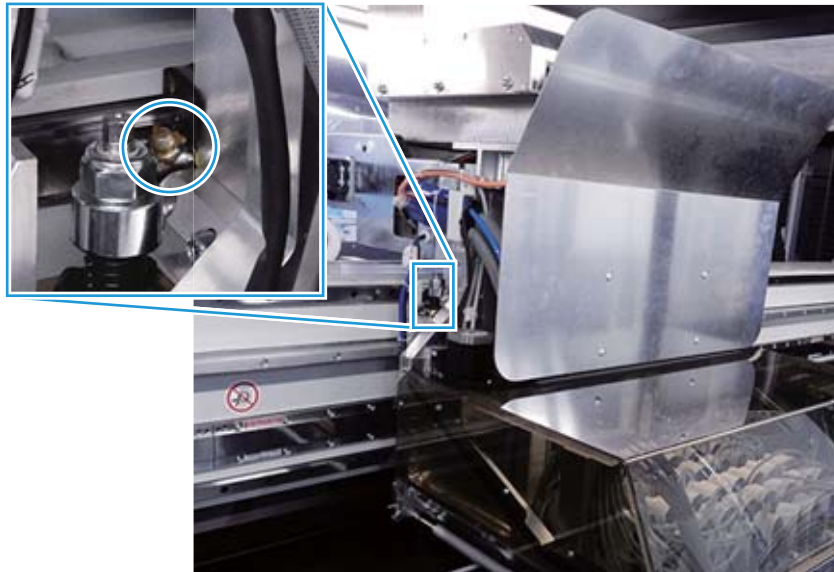

**21** When work is finished, close the front covers.

**22** Turn the main power switch to 1 (ON) to turn the power on.

**23** Start up Leonardo.

**24** Release the emergency stop button.

**25** Execute Setpoint.

On the Leonardo operation screen, click [Setpoint] and then press the reset button on the main electric panel. The head carriage moves to the cleaning station.

This completes the work.

## Checking for Water Leaks in the Pipe Joints

Frequency	Every month
User Permissions	L
Personal Protective Equipment	Protective gloves and clothing

- 1** Check that the machine is in the Power Off Status.  
(For more information, refer to ["Power Off Status" on Page 10.](#))
- 2** Check that the joints for the cleaning tank of the cleaning unit [1] and [2] are not loosened and are free water leaks.

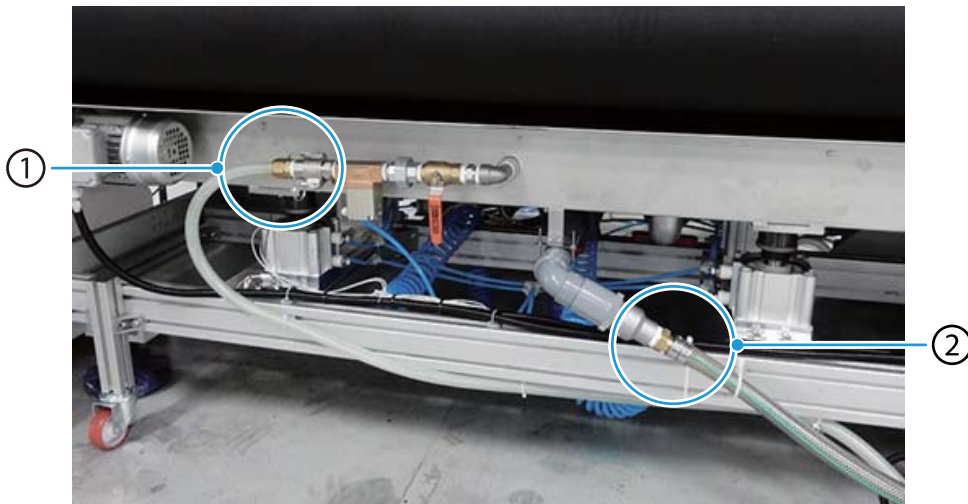

This completes the work.

## Cleaning/Replacing the Mist Filter

Frequency	Cleaning: Every month Replacement: When necessary
User Permissions	L
Personal Protective Equipment	Protective gloves and clothing
Required Items	Replacement: Replacement mist filter (Consumables)

- 1** Check that the machine is in the Power Off Status.  
(For more information, refer to ["Power Off Status" on Page 10.](#))
- 2** Remove the mist filter cover from the mist filter on the side face of the machine.  
Remove the two screws and remove the cover.



- 3** Remove the two screws from the mist filter cover and remove the cover.



**4 Pull out the mist filter.**

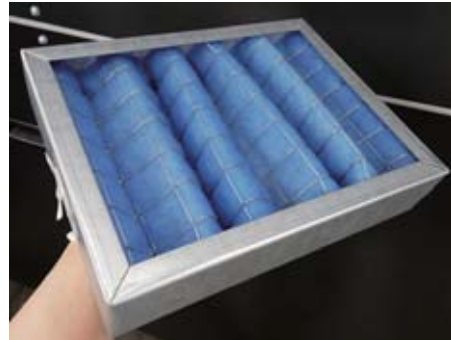

**5 Clean the removed mist filter with water.**

**6 Dry the filter thoroughly and attach it again.  
Replace the filter if it is extremely dirty.**



Make sure that the mist filter is set in the correct direction while attaching it.  
Top side: Blue, Bottom side: White  
If you have cleaned the filter, do not insert it until it has dried.

**7 After cleaning the mist filter, close the mist filter cover, tighten the two screws, and attach the mist filter cover.**

This completes the work.

## Checking the Blower and Cleaning/Replacing the Filter

Frequency	Inspection: Every month Cleaning/Replacement: When necessary
User Permissions	L
Personal Protective Equipment	Protective gloves and clothing
Required Items	Replacement: Replacement blowing fan filter (Consumables)

Clean the filter for the blower at the rear side of the machine.

- 1** Check that the machine is in the Power Off Status.  
(For more information, refer to ["Power Off Status" on Page 10.](#))
- 2** Remove the screw from the filter cover.



- 3** Lift the cover to remove it.



- 4** Remove the filter and clean dirt and dust with a vacuum cleaner.



- 5** After cleaning, attach the filter again.  
Replace the filter if it is extremely dirty.

This completes the work.

## Cleaning/Replacing the Cooling Fan Filters

If the cooling fan filters are used continuously without cleaning, the machine will become unable to lower the temperature of the print head drive substrate, which may result in a failure. Follow the procedures below to clean the cooling fan filters.

If a stain cannot be removed even after cleaning, that cooling fan filter must be replaced. Refer to "[Replacing the Cooling Fan Filters](#)" on Page 108 for the replacement procedures.

To purchase new cooling fan filters, inquire with qualified service personnel.

Frequency	Every month When an error message is displayed stating that the temperature of the print head drive substrate cannot be lowered
User Permissions	L

### Cleaning the Cooling Fan Filters

Required Items	Plastic container, tray, and personal protective equipment (protective gloves and clothing, eye protection)
----------------	---

- 1 Check that the machine is in the Power Off Status.**  
(For more information, refer to "[Printing Standby Status](#)" on Page 10.)
- 2 Open the front cover.**



- 3** While holding the cooling fan cover so that it does not fall, loosen the four screws on the cover using the hex key (width: 3 mm) and remove the cover.

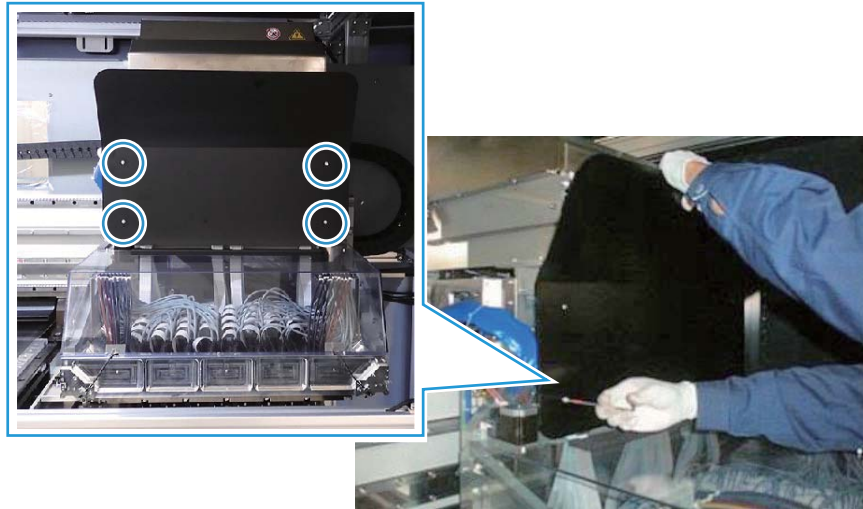

- 4** Remove all eight cooling fan filters.

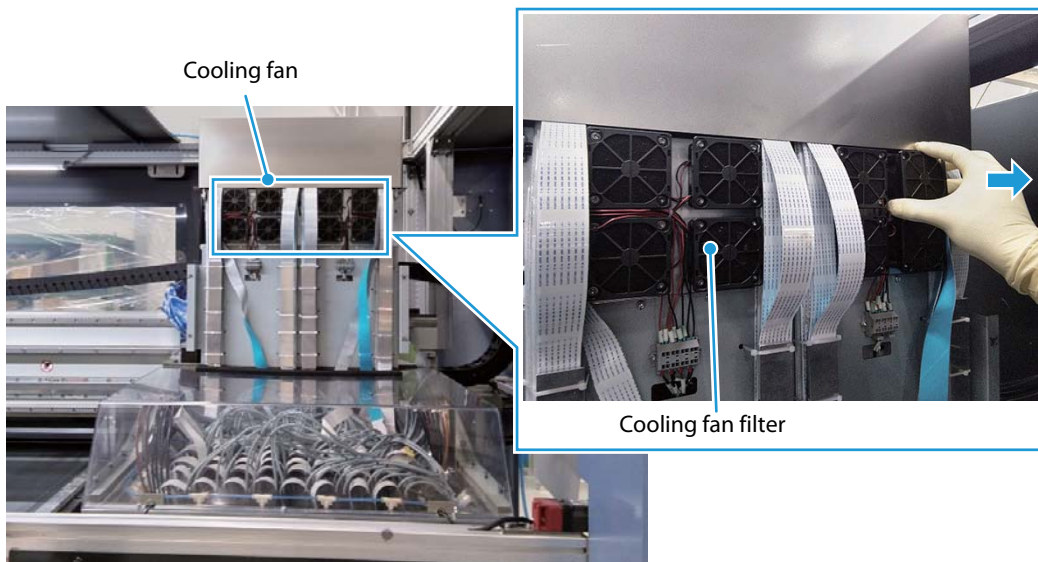

- 5** Remove the cooling fan filter from the cover.

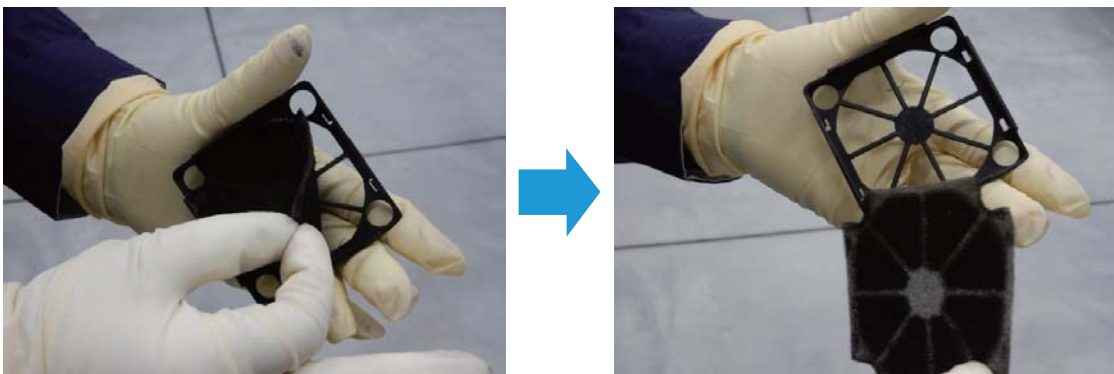

**6 Put tap water into the plastic container.**

	Wash the cooling filter on the tray, so as not to spill dirty water.
---	--

**7 Place the cooling fan filter in the plastic container and wash off the stains by hand.**

	The dirty water is industrial waste. Dispose of it in the proper manner.
---	--

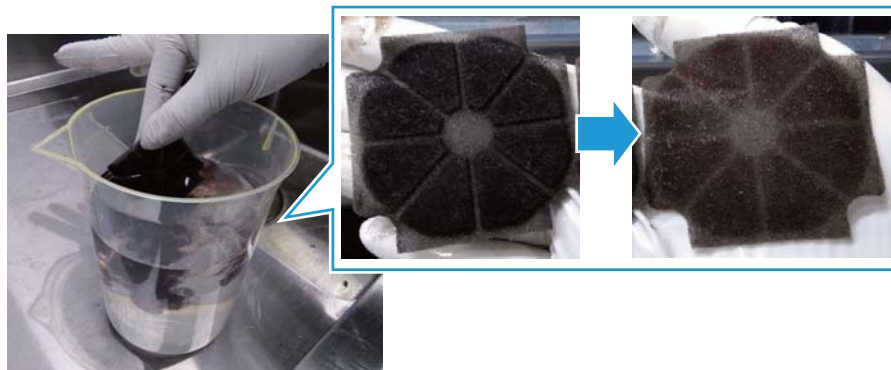

**8 Thoroughly dry the cooling fan filter.**

**9 Place the cooling fan filter on the cover.**

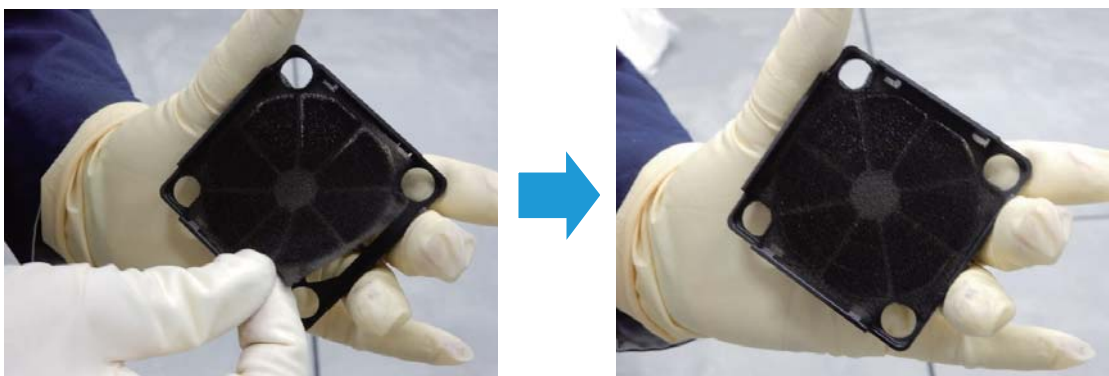

**10 Install all the cooling fan filters in their original positions.**

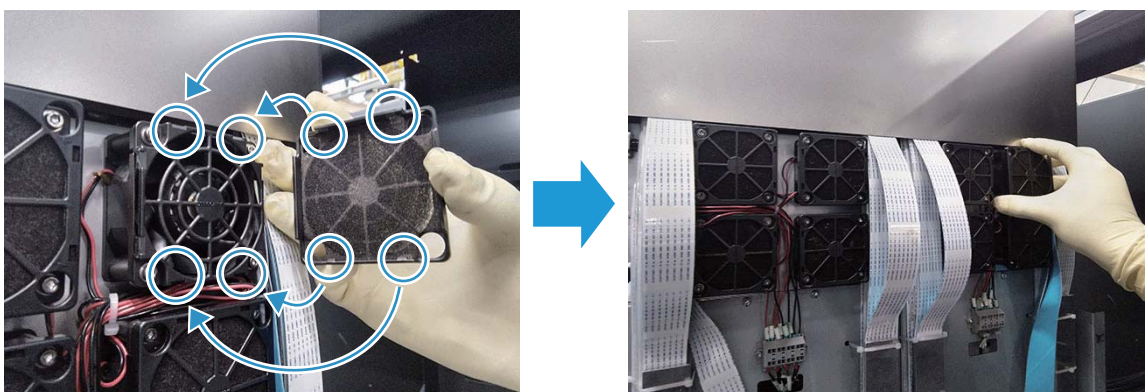

- 11 Attach the cooling fan cover and tighten the four screws using the hex key (width: 3 mm).

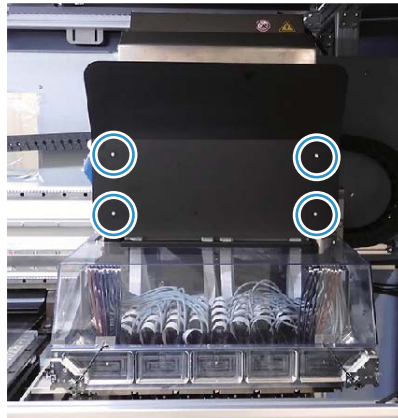

- 12 Close the front cover.



This completes the work.

## Replacing the Cooling Fan Filters

Required Items	New cooling fan filters (Consumables) and personal protective equipment (protective gloves and clothing, eye protection)
----------------	--

- 1** Check that the machine is in the Power Off Status.  
(For more information, refer to "Printing Standby Status" on Page 10.)
- 2** Open the front cover.



- 3** While holding the cooling fan cover so that it does not fall, loosen the four screws on the cover using the hex key (width: 3 mm) and remove the cover.

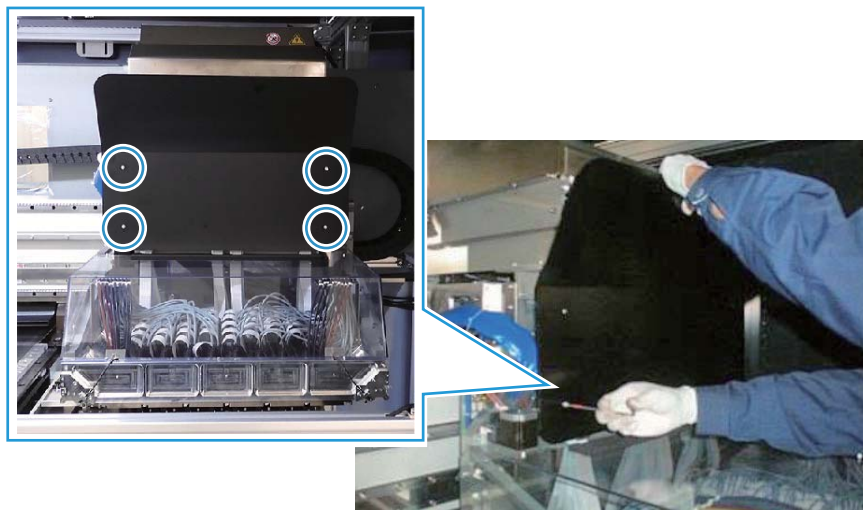

**4 Remove the cooling fan filters.**

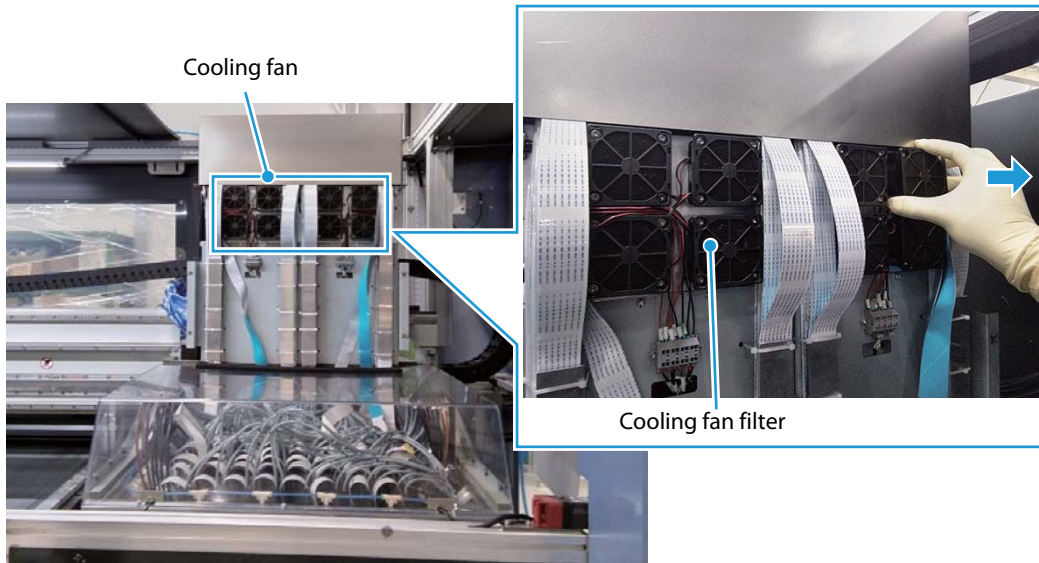

**5 Remove the cooling fan filter from the cover.**

	<p>A dirty filter is industrial waste. Dispose of it in the proper manner.</p>
--	--

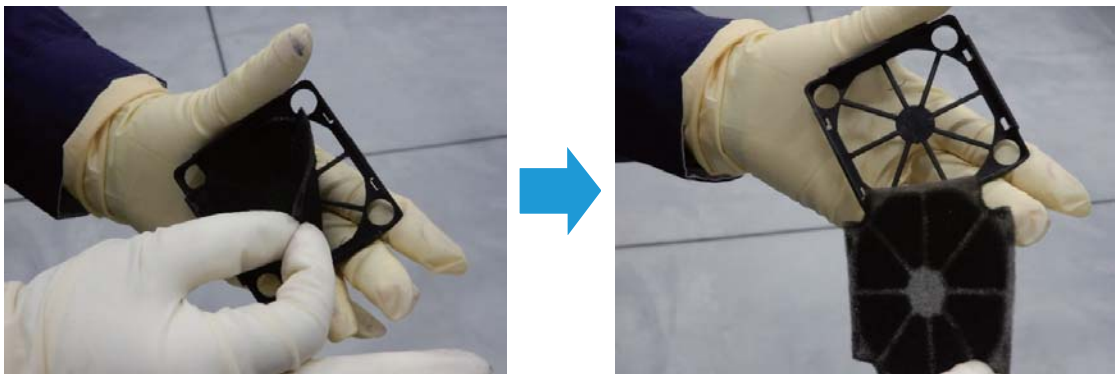

**6 Place the new cooling fan filter on the cover.**

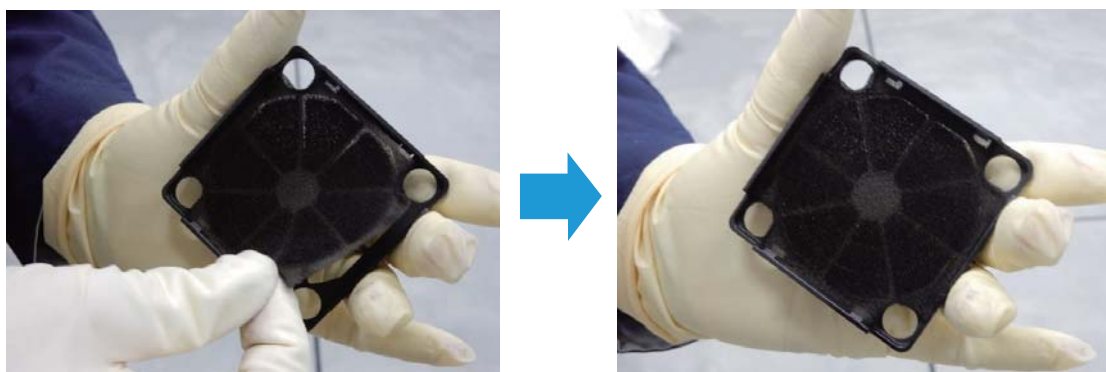

- 7** Install the cooling fan filters straight in their original positions, with the cover protrusions on the top and bottom sides.

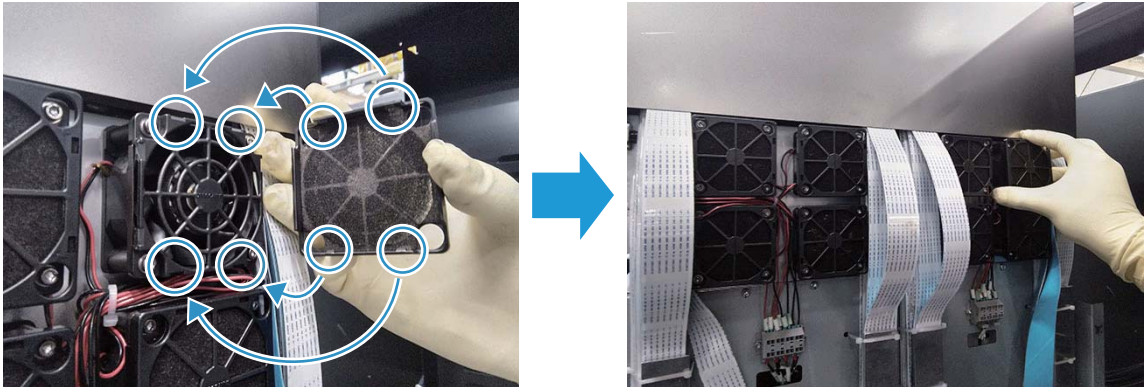

- 8** Attach the cooling fan cover and tighten the four screws using the hex key (width: 3 mm).

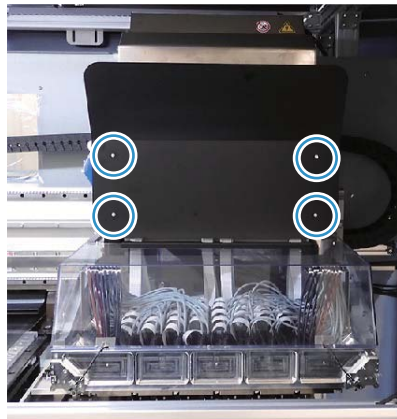

- 9** Close the front cover.



This completes the work.

## Checking the Cable Protection Condition

Frequency	Every month
User Permissions	L
Personal Protective Equipment	Protective gloves and clothing

- 1** Check that the machine is in the Power Off Status.  
(For more information, refer to ["Power Off Status" on Page 10.](#))
- 2** Check the cable protective tubes between the machine and the main electric box for any damage.

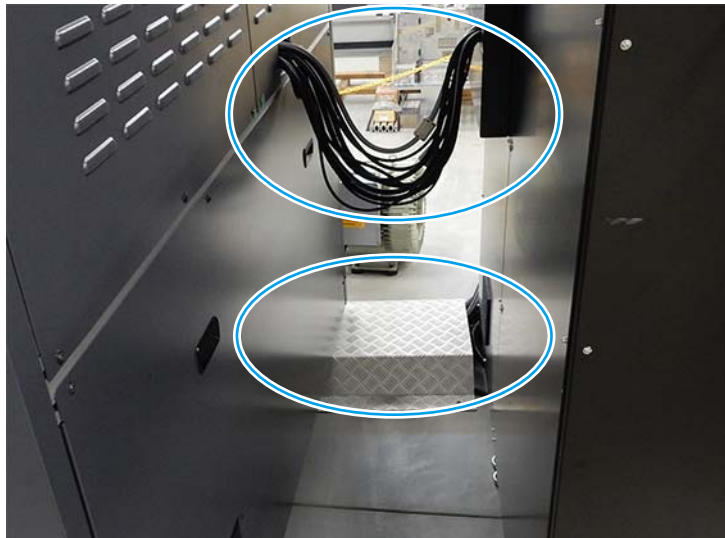

This completes the work.

## Shaking the Ink Cartridges

Frequency	When the machine was not used for a long period of time with the ink cartridges still installed <ul style="list-style-type: none"> <li>• Pigment ink (Red): Once every 3 weeks</li> <li>• Pigment ink (other than Red), dispersion ink: Once a month</li> <li>• Reactive ink, acidic ink: Shaking not required</li> </ul>
User Permissions	L
Personal Protective Equipment	Protective gloves and clothing

When the machine has not been used for a long period of time with the ink cartridges still installed, remove the cartridges and shake them.

This operation can be done with the machine power turned on or off.

The shaking method to be followed after the installation differs from that followed when opening the ink cartridge. Follow the procedures below for shaking.

- 1 Pull the ink rack front bar towards you and down.**
- 2 Grab the blue levers on both sides of the connector, and then pull it out toward you.**

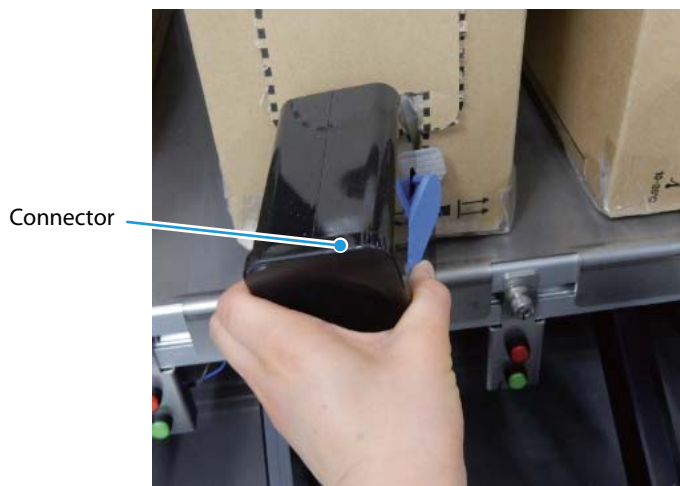

- 3 Remove the ink cartridge from the ink rack, and place it on a flat surface with the ink supply port facing the side.**

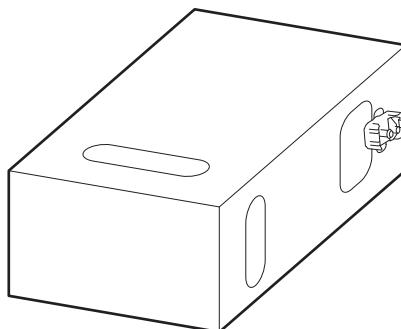

- 4** Slide the ink cartridge back and forth longitudinally within a range of approximately 10 cm. Do three times for the front and back. Move the ink cartridge at a rate of one back-and-forth cycle per second.

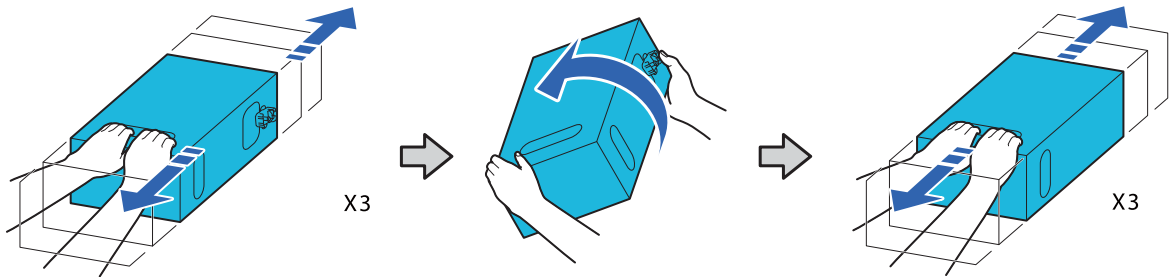

- 5** Place the shaken ink cartridge such that the ink supply port faces the connector
- 6** Insert the connector of the ink rack into the ink supply port of the ink cartridge. Push the needle of the connector into the ink supply port of the ink cartridge. Insert it carefully and securely as shown in the following image.

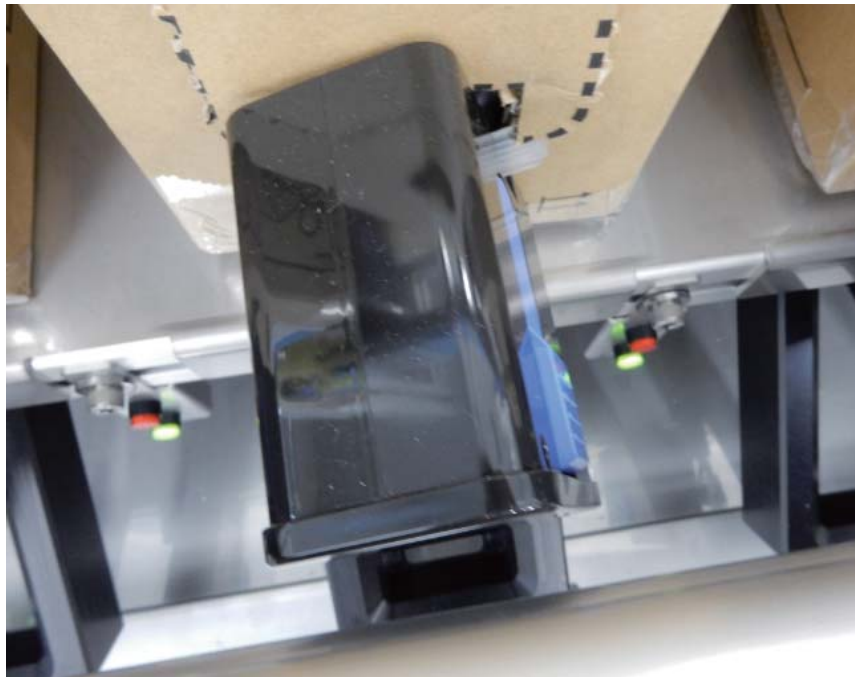

- 7** Raise the ink rack front bar up.

This completes ink replacement.

Repeat the same procedure to shake other ink cartridges.

# Adjustment Procedure

## *Bi-directional Adjustment*

Frequency	When replacing heads/When changing jobs
User Permissions	H
Personal Protective Equipment	Protective gloves and clothing

Before adjusting Bi-D, perform the following procedures.

- First, perform a print job to see if Bi-D is set correctly.
- If Bi-D adjustment is required, refer to the Operation Guide and set the [Fabric thickness] correctly.
- If normal printing is not possible even after adjusting the [Fabric thickness], follow the procedures in this section to set the correct value for Bi-D.

Adjust the ink dot position in the head reciprocating path. Make adjustment when vertical misalignment occurs.

- 1 Check that the machine is in the Printing Standby Status.**  
(For more information, refer to ["Printing Standby Status" on Page 10.](#))
- 2 From the printed result of a printing job, measure the misaligned amount in mm.**

- 3** On the Leonardo operation screen, open [Maintenance] [1] and enter an adjustment value in [Bidirectional] [2]. Then press the enter key on the keyboard. An adjustment value of up to 0.500 can be entered. Entering "0.500" moves the ink dot position by 1 mm.

+ side: Moves the returning path toward the cleaning station side.

- side: Moves the returning path toward the flushing plate side.

To enter a value larger than 0.500, save the value first by pressing [3], which resets the counter to "0". Then enter an additional value.

Example: To move the position by 1.5 mm

Enter "0.500" (1 mm) and press enter key on the keyboard. Press [3] to reset the counter to "0". Then enter an additional "0.250" (0.5 mm) and press enter key on the keyboard.

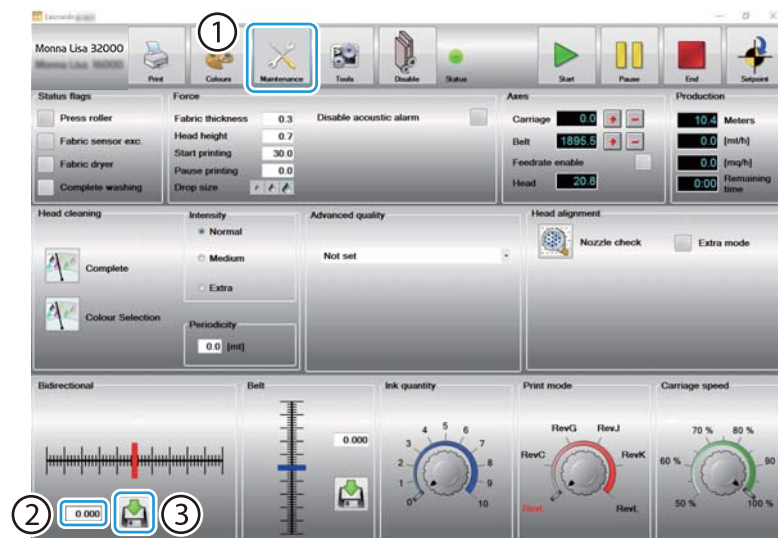

- 4** Press [3] to save the settings.



If the settings are configured here, the factory settings will be lost.

- 5** Print again and check the result.

This completes the work.

## Belt Feed Amount Adjustment

Frequency	When sideways streaking occurs/When changing jobs
User Permissions	H
Personal Protective Equipment	Protective gloves and clothing

When sideways streaking occurs horizontally in print results, adjust the belt feed amount at every printing pass.

- 1 Check that the machine is in the Printing Standby Status.**  
(For more information, refer to "Printing Standby Status" on Page 10.)
- 2 From the printed result of a printing job, check the misaligned amount.**
  - ” When white sideways streaking occurs:  
A gap occurs between printing passes because the belt feeding amount is too much.  
Decrease it using the following procedure.
  - ” When dark sideways streaking occurs:  
Printing passes overlap because the belt feeding amount is insufficient.  
Increase it using the following procedure.
- 3 On the Leonardo operation screen, open [Maintenance] [1] and enter an adjustment value in [Belt] [2]. Then press the enter key on the keyboard. An adjustment value of up to 0.500 can be entered.**

Plus side: Increases the belt feed amount.

Minus side: Decreases the belt feed amount.

To enter a value larger than 0.500, save the value first by pressing [3], which resets the counter to "0". Then enter an additional value.



#### 4 Press [3] to save the settings.



Double-check that the settings are correct before saving them. If you save the settings, the factory settings will be lost.

#### 5 Print again and check the result.

This completes the work.

# Replacement Procedure

## Cap Replacement

Frequency	When necessary/When a problem occurs (For example, when nozzle clogging is not resolved by cleaning)
User Permissions	L
Personal Protective Equipment	Eye protection, protective gloves and clothing
Required Items	Replacement cap unit (consumables), forceps, hex key (width: 2.5 mm), maintenance liquid, cleaning stick, plastic container

 <b>CAUTION</b>	Be sure to wear eye protection. Failure to do so could cause ink to splash into the eyes.
--	---

- 1** Check that the machine is in the **Printing Standby Status**.  
(For more information, refer to ["Printing Standby Status" on Page 10.](#))
- 2** Move the print head carriage to a position above the flushing plate.  
On the Leonardo operation screen, open [Maintenance] (1), and click [+] (2) for [Carriage] under [Axes] once. When the head carriage moves to the center, click [+] again.  
The carriage moves to the left, to a position above the flushing plate.

	Do not work for a long period of time while the head carriage is uncapped. Doing so can cause the print head nozzles to clog, causing a printing error. Pigment ink in particular causes a failure if left uncapped for 24 hours.
---	---

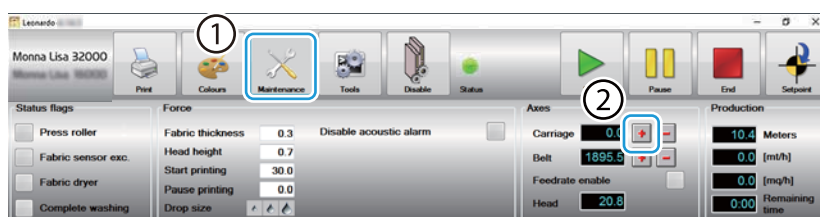

- 3** Press the emergency stop button.
- 4** Close the Leonardo screen and shut down the control PC.
- 5** Turn the main power switch to 0 (OFF) to turn the power off.

## 6 Open the front cover.



## 7 A cap unit is equipped with four caps. Loosen the screw at the center of the cap unit with the hex key (width: 2.5 mm).

**CAUTION**

Make sure that the machine's power is off before performing work.



## 8 While taking care not to let the springs fall out, lift the cap upward keeping it horizontal.



- 9** Hold the ink tubes with the forceps.

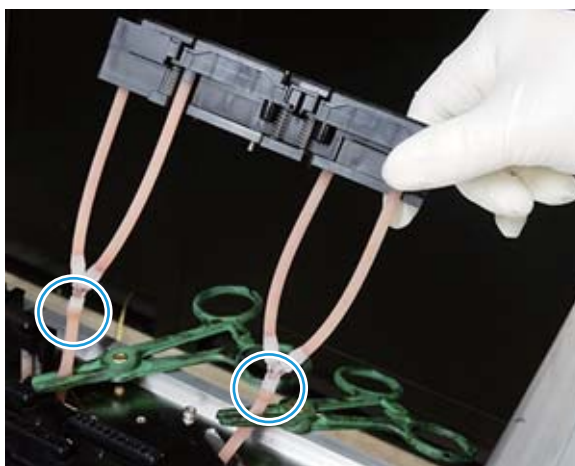

- 10** Pull out the ink tubes at the locations indicated by circles.  
Be careful of splashing ink.
- 11** Insert tubes into a new cap unit.  
Insert the tubes securely as far as possible.



Do not touch the lip surface of the cap.

- 12** Remove the forceps from the ink tubes.
- 13** Attach the cap unit.  
Make sure that all springs are installed.  
Make sure that the cap is set horizontally.
- 14** While wearing rubber gloves, use your finger to push the lip of the cap in and see if it returns.



- 15** Secure the cap unit by tightening the screw at the center with the hex key (width: 2.5 mm).

- 16** Grease may have oozed out of the surface of the lip section.  
Wipe the lip section gently using the cleaning stick moistened with maintenance liquid.



Wipe off the maintenance liquid from the surface of the cap.

- 17** After replacement, make sure that no tools or other items are left on the print head operating area or carriage operating area.
- 18** Close the front cover.
- 19** Turn the main power switch to 1 (ON) to turn the power on.
- 20** Start up Leonardo.
- 21** Release the emergency stop button.
- 22** Execute Set point.  
On the Leonardo operation screen, click [Setpoint] and then press the reset button on the main electric box. The print head carriage moves to the cleaning station.

This completes the work.

## Wiper Unit Replacement

Frequency	When necessary/When a problem occurs (For example, when nozzle clogging is not resolved by cleaning)
User Permissions	L
Personal Protective Equipment	Eye protection, protective gloves and clothing
Required Items	Replacement wiper unit (consumables), hex key (width: 2.5 mm), maintenance liquid, cleaning stick, cleaning wiper, plastic container

 <b>CAUTION</b>	Be sure to wear eye protection. Failure to do so could cause ink to splash into the eyes.
--	---

- 1** Check that the machine is in the **Printing Standby Status**.  
(For more information, refer to ["Printing Standby Status" on Page 10.](#))
- 2** Move the print head carriage to a position above the flushing plate.  
On the Leonardo operation screen, open [Maintenance] (1), and click [+] (2) for [Carriage] under [Axes] once. When the head carriage moves to the center, click [+] again.  
The carriage moves to the left, to a position above the flushing plate.

	Do not work for a long period of time while the head carriage is uncapped. Doing so can cause the print head nozzles to clog, causing a printing error. Pigment ink in particular causes a failure if left uncapped for 24 hours.
---	---



- 3** Press the emergency stop button.
- 4** Close the Leonardo screen and shut down the control PC.
- 5** Turn the main power switch to 0 (OFF) to turn the power off.

## 6 Open the front cover.



## 7 Remove the wiper unit. Loosen the screw that secures the wiper unit at the center with the hex key (width: 2.5 mm) and remove the wiper unit.



Make sure that the machine's power is off before performing work.

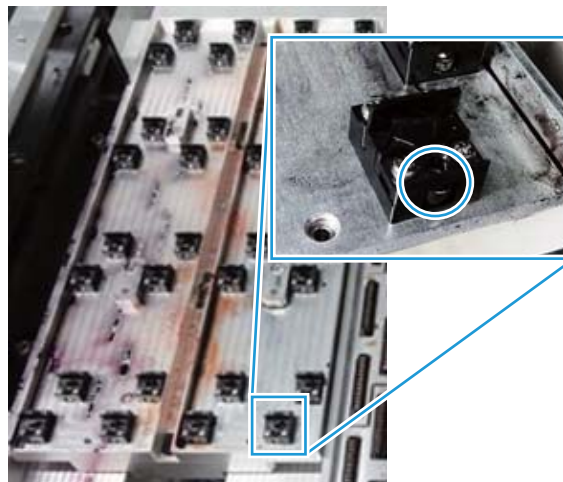

## 8 Wipe the location where the wiper unit is removed using the cleaning cloth or cleaning stick moistened with maintenance liquid.

- 9 Attach a new wiper unit.**  
Insert the pin at the installation position into the hole on the bottom surface of the wiper unit.

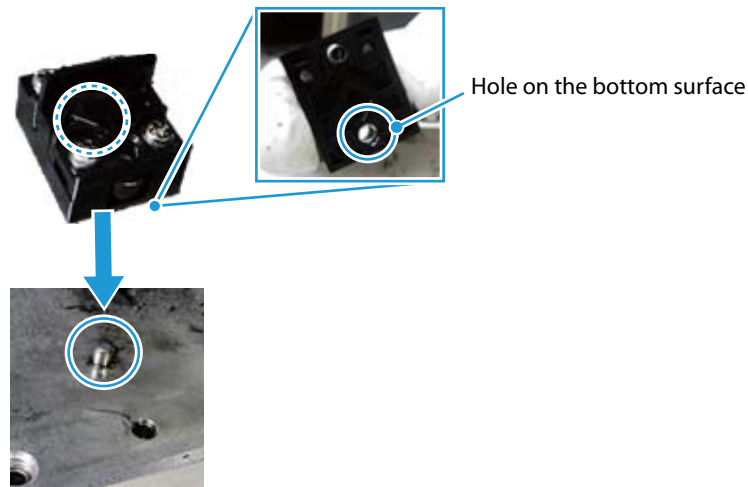

- 10 Tighten the screw on the wiper unit with the hex key (width: 2.5 mm).**



Do not pull the rubber part of the wiper unit.  
When attaching the wiper unit, make sure that the unit is installed in the proper position and direction.



- 11 Grease may have oozed out of the rubber surface.**  
Wipe the wiper rubber section gently using the cleaning stick moistened with maintenance liquid.



Dry the wiper rubber section after wiping it with maintenance liquid.

- 12** After replacement, make sure that no tools or other items are left on the print head operating area or carriage operating area.
- 13** Close the front cover.
- 14** Turn the main power switch to 1 (ON) to turn the power on.
- 15** Start up Leonardo.
- 16** Release the emergency stop button.
- 17** Execute Set point.  
On the Leonardo operation screen, click [Setpoint] and then press the reset button on the main electric box. The print head carriage moves to the cleaning station.

This completes the work.

## Towel Roller Fabric Replacement

Frequency	When necessary/When a problem occurs
When to Replace	Replace the fabric attached to the towel roller when it is very wet or dirty. If you continue to use it without replacing it, the water left on the belt will not be sufficiently wiped up, leaving water remaining on the belt.
User Permissions	L
Personal Protective Equipment	Protective clothing, protective gloves (for when you touch the ink-stained fabric)
Required Items	Replacement fabric: Non-fluffy fabric with good water-absorption properties (Cotton recommended. Size: 1,850 x 1,600 mm), double-sided tape (Thick), alcohol disinfectant, wipe cloth

- 1** Check that the machine is in the Power Off Status.  
(For more information, refer to "Power Off Status" on Page 10.)
- 2** Check that the towel roller is on top of the supporting screws.
- 3** Remove the towel roller from the machine.  
Firmly hold the towel roller in both hands, lift it up slowly and horizontally following the left and right grooves, and remove it from this machine.



Be careful not to interfere with the fabric edge sensor unit, which is located directly below the towel roller. When removing the towel roller, you can avoid interference by tilting the sensor diagonally.

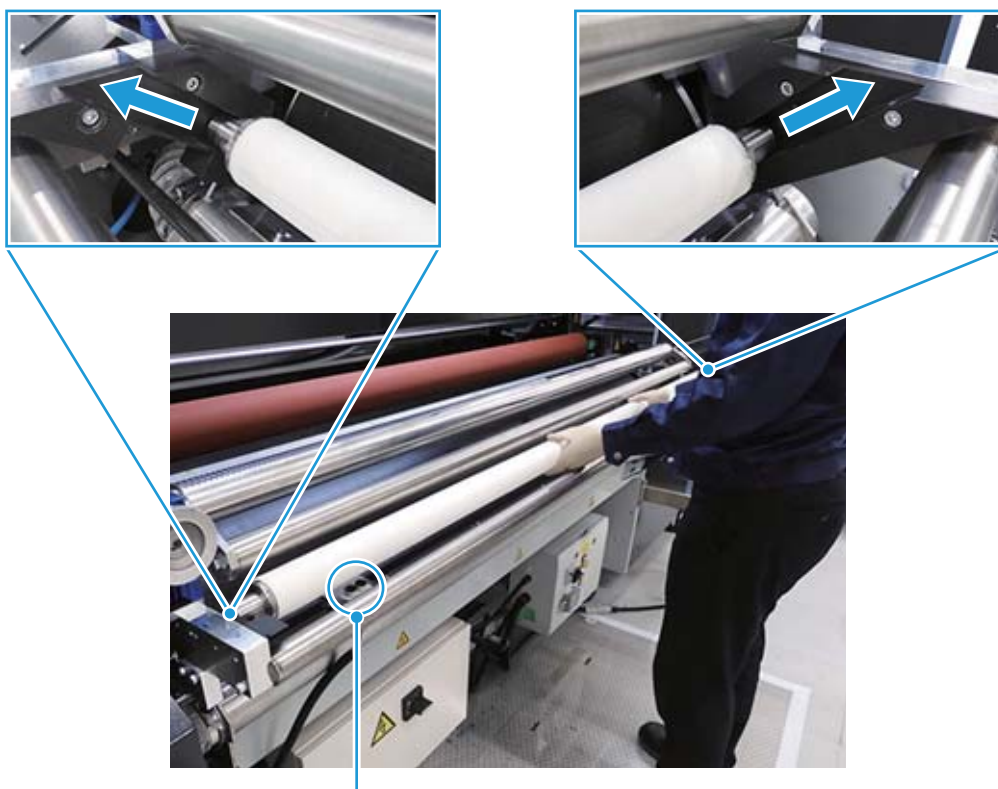

Fabric edge sensor unit

- 4 Place the towel roller on a horizontal location.
- 5 Peel off the double-sided tape from the edge of the fabric, and remove the fabric.



- 6 Use a wipe cloth soaked in alcohol disinfectant to remove any tape adhesive left on the towel roller shaft.
- 7 Spread out the replacement fabric on a level location free from foreign material.

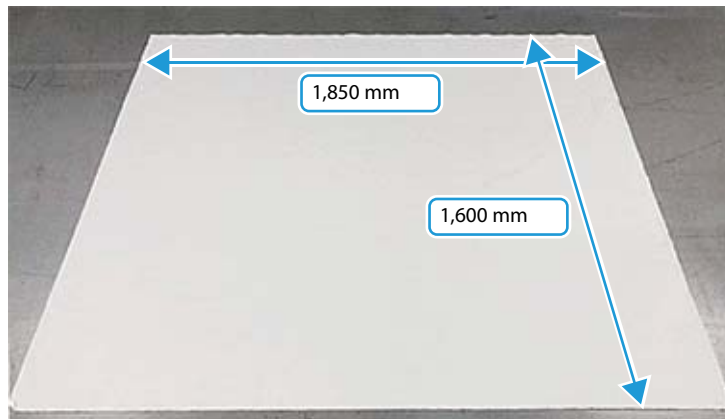

- 8 Place the towel roller on the edge of the fabric, and affix the opposite side using curing tape.



**9** Apply double-sided tape to the towel roller shaft.



**10** (1) Peel off the liner of the tape applied to the towel roller, then (2) press the tape up against the fabric edge to adhere it.

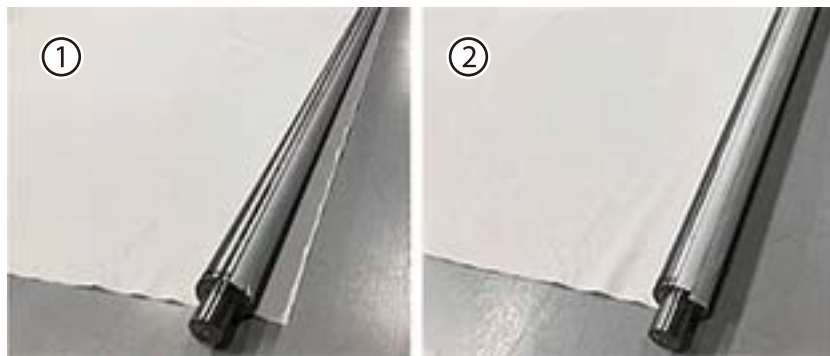

**11** Turn the towel roller horizontally to roll up the fabric.



- 12** When you reach the edge of the fabric, peel off the curing tape and apply double-sided tape to the fabric edge.

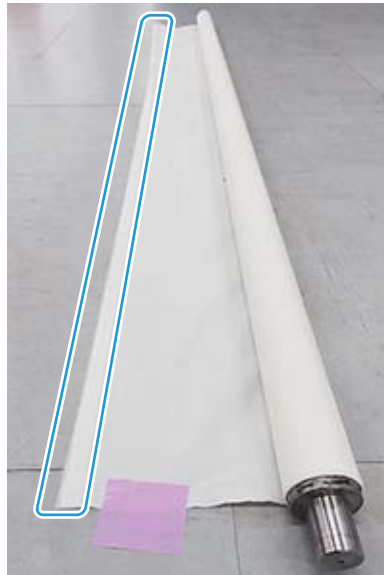

- 13** Peel off the tape liner, and then adhere the fabric edge to the towel roller.



- 14** Attach the towel roller to this machine.  
Firmly hold the towel roller in both hands, and move to the rear of this machine.
- 15** Align the towel roller shaft with the left and right towel roller grooves, and slowly and horizontally lower it. Place the left and right ends of the shaft on the supporting screws.

This completes the work.

## Replacing the Washing T-shaped Scraper

Frequency	When necessary
When to Replace	When the area in contact with the glue belt is worn/deteriorated. If the contacting area is worn/deteriorated, water cannot be wiped off completely after belt cleaning, resulting in water remaining on the belt.
User Permissions	L
Personal Protective Equipment	Protective gloves and clothing
Required Items	Replacement washing T-shaped scraper (consumables), two belt cleaning unit wheels, hex key (width: 6 mm)

- 1 Check that the machine is in the Power Off Status.**  
(For more information, refer to ["Power Off Status" on Page 10.](#))
- 2 Turn the left drain valve in the direction of the arrow to close it.**

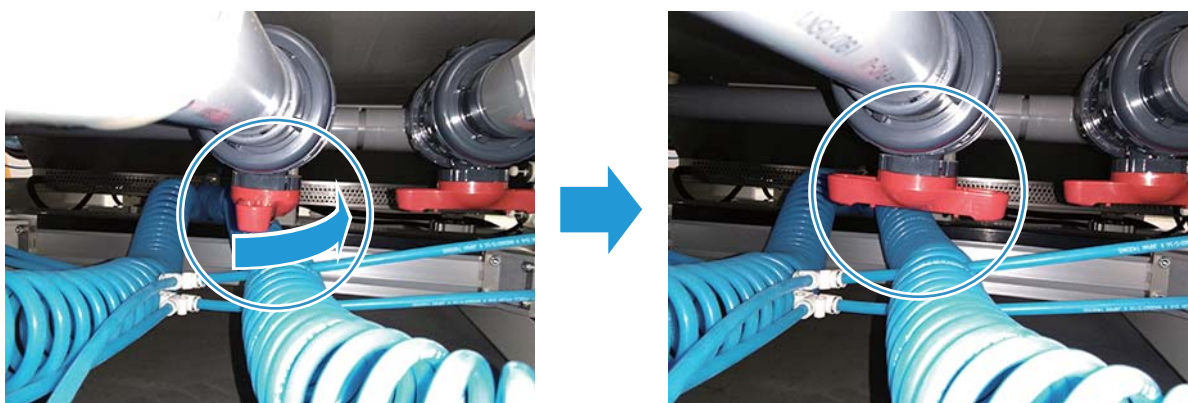

- 3 Remove the screw from each fastener that secures the belt cleaning unit at two locations using the hex key (width: 6 mm).**
- 4 Pull the belt cleaning unit toward you until the carriage rail hits the stopper nearest from you.**

- 5** Attach the belt cleaning unit wheels on the right and left sides. Use the nut in the frame on the rear of the cleaning unit.

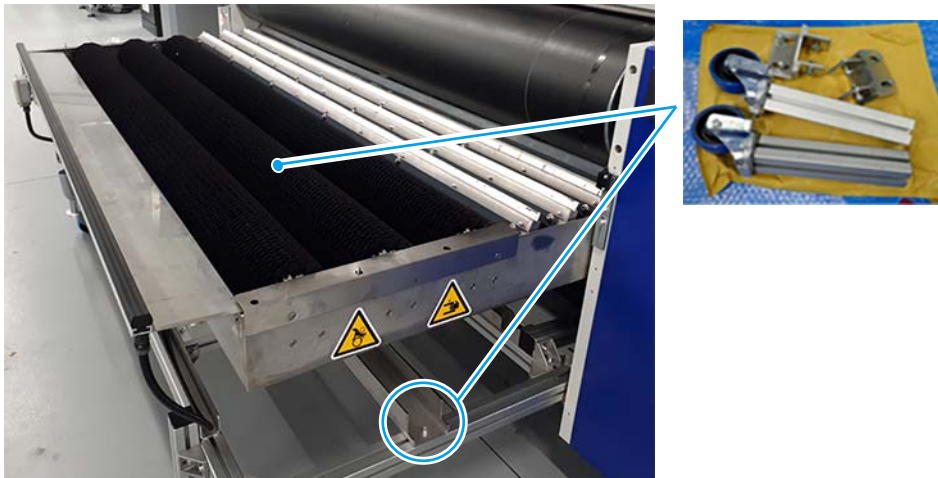
**CAUTION**

When you pull out the belt cleaning unit, an emergency stop occurs.

- 6** Remove the stopper and pull out the belt cleaning unit completely
- 7** Remove the fixing plate that secures the washing T-shaped scraper to be replaced. Remove the screw and washer [1] on the fixing plate on the side to be pulled out using the spanner (width: 7 mm), and remove the fixing plate [2].



Be careful not drop the screw, washer, and fixing plate into the cleaning tank.

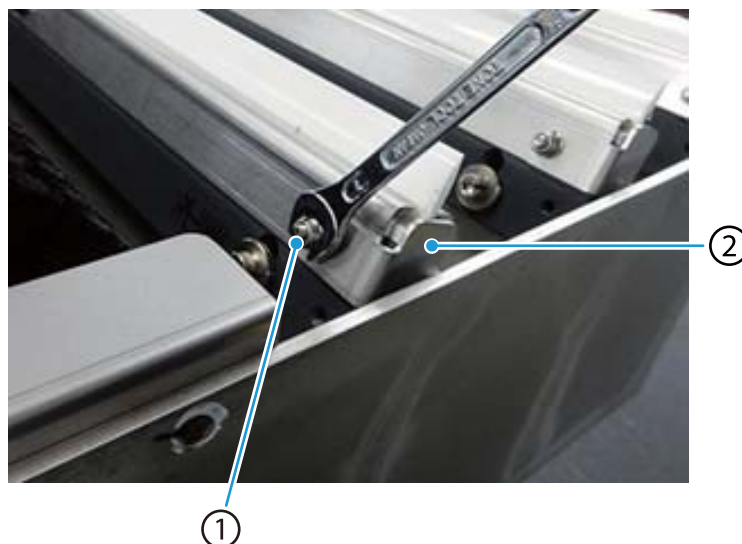

- 8** Loosen the 10 screws that secure the whole scraper. While holding the screw hole behind the screw with the hex key (width: 2.5 mm), loosen the screw with the spanner (width: 7 mm).

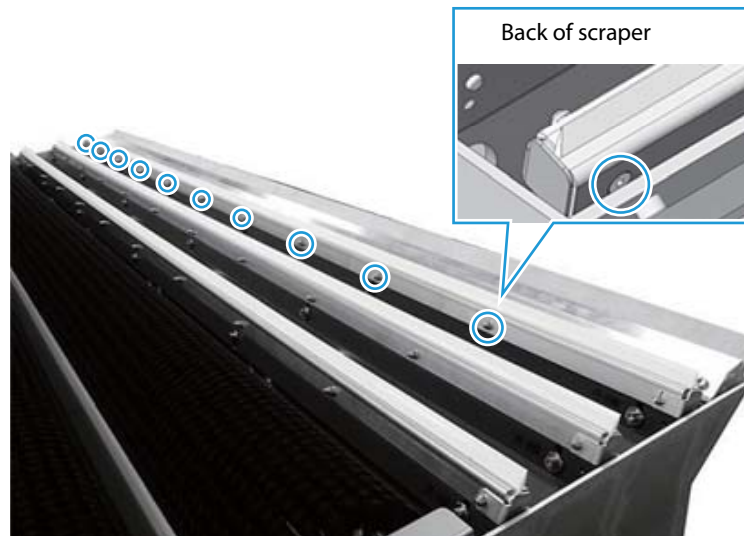

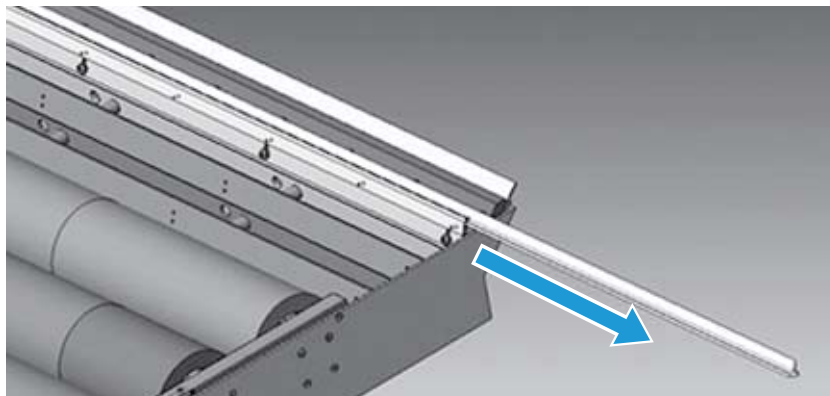

- 9** Pull out the scraper. If fluffy dust has become fused, remove it first as the scraper may be stuck when pulled out.



- 10** Insert a new scraper in the location where the scraper was pulled out.
- 11** Tighten the 10 screws that secure the whole scraper using the spanner (width: 7 mm) and hex key (width: 2.5 mm).
- 12** Attach the fixing plate. Secure the screw, washer and fixing plate using the spanner (width: 7 mm). This completes the replacement procedure.
- 13** Return the belt cleaning unit to the original position. Return the belt cleaning unit to the carriage rail. Attach the stopper and remove the belt cleaning unit wheels.

**14** Push the belt cleaning unit to the original position. Then tighten the screw on the fastener at two locations with the hex key (width: 6 mm).

	<p>Insert the belt cleaning unit straight into its original position. If it is inserted at an angle, the belt cleaning unit position sensor in the left rear will be unable to detect it, and therefore the emergency stop status may not be released.</p> <p>Belt cleaning unit position sensor</p> 
---	---

**15** Turn the left drain valve in the direction of the arrow to open it.

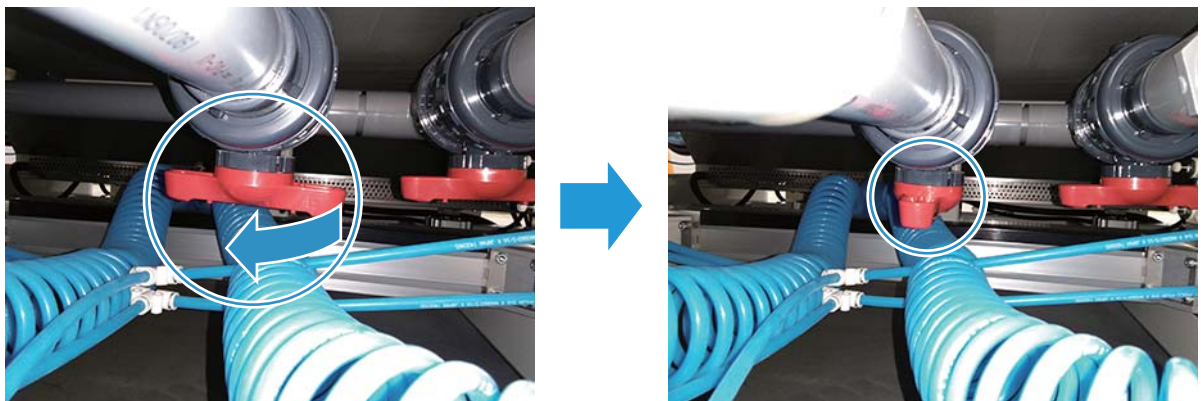

This completes the work.

## Replacing the Washing Silicone Scraper

Frequency	When necessary
When to Replace	When the area in contact with the glue belt is worn/deteriorated. If the contacting area is worn/deteriorated, water cannot be wiped off completely after belt cleaning, resulting in water remaining on the belt.
User Permissions	L
Personal Protective Equipment	Protective gloves and clothing
Required Items	Replacement washing silicon scraper (consumables), two belt cleaning unit wheels, hex key (width: 4 mm)

- 1** Check that the machine is in the Power Off Status.  
(For more information, refer to ["Power Off Status" on Page 10.](#))
- 2** Pull out the belt cleaning unit.  
Perform steps 1 to 6 in "Replacing the washing T-shaped scraper." For more information, refer to ["Replacing the Washing T-shaped Scraper" on Page 130.](#)

 <b>CAUTION</b>	When you pull out the belt cleaning unit, an emergency stop occurs.
---	---

- 3** Remove the washing silicone scraper to be replaced.  
Loosen the 15 screws that secure the silicon scraper using the hex key (width: 4 mm).
- 4** Lift out the silicone scraper and attach a new silicone scraper.

- 5** Return the belt cleaning unit to the original position.  
Perform steps 13 and 15 in "Replacing the washing T-shaped scraper." For more information, refer to ["Replacing the Washing T-shaped Scraper" on Page 130](#).



Insert the belt cleaning unit straight into its original position.  
If it is inserted at an angle, the belt cleaning unit position sensor in the left rear will be unable to detect it, and therefore the emergency stop status may not be released.

Belt cleaning unit position sensor



This completes the work.

## Sponge Roller Replacement (ML-32000-340)

This section applies to ML-32000-340.

Frequency	When necessary/When a problem occurs
When to Replace	Replace the sponge roller when it becomes worn or deteriorated. If the sponge rollers are worn or deteriorated, water cannot be completely wiped off after belt cleaning and will remain on the belt.
User Permissions	L
Required Number of Workers	3 persons
Personal Protective Equipment	Eye protection, protective gloves and clothing
Required Items	Replacement sponge, Sponge roller tank, two belt cleaning unit wheels, hex key (width: 6 mm), screwdriver (PH2)



### CAUTION

Due to the weight of the belt cleaning unit, it should be pulled out and returned to its original position by the workers indicated above.  
Due to the weight of the sponge roller, it should be installed and removed by two workers.

Before starting work, turn off the machine.

- 1 Turn the left drain valve in the direction of the arrow to close it.

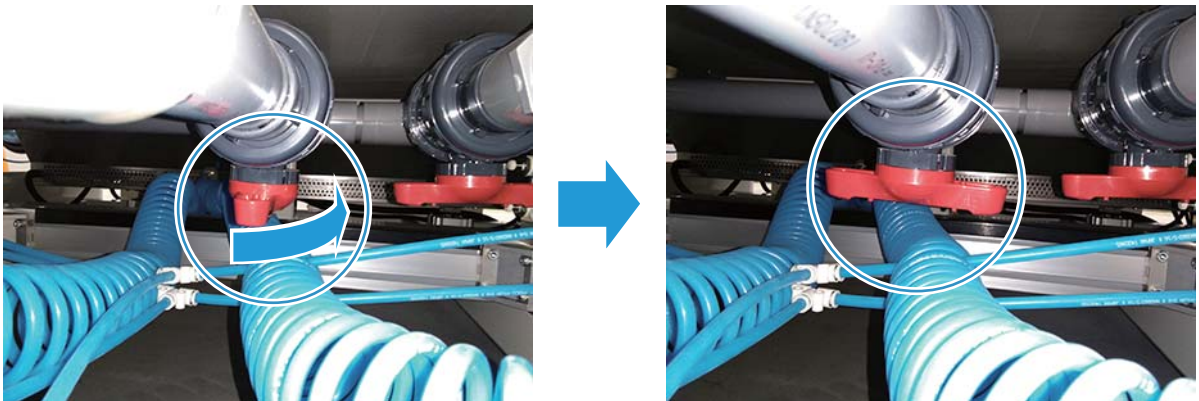

- 2** Remove the one screw of each fixing block [2] on the left and right using the hex key (width: 6 mm).



Store the removed screws to ensure they are not dropped or placed somewhere they can cause damage.

Right side

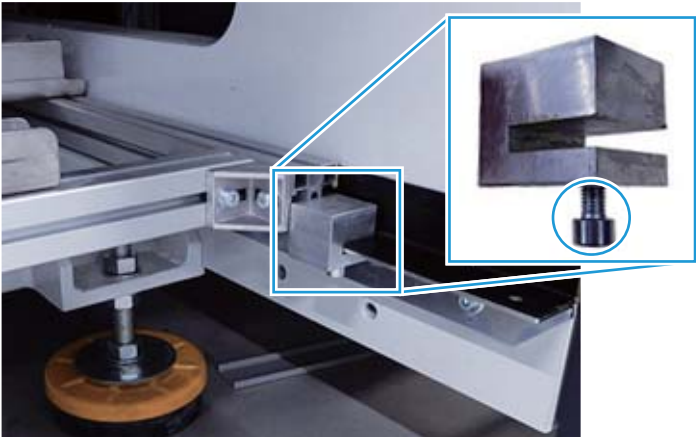

Left side



- 3** Pull the belt cleaning unit toward you until the carriage rail hits the stopper nearest from you.



#### 4 Remove the sponge roller.

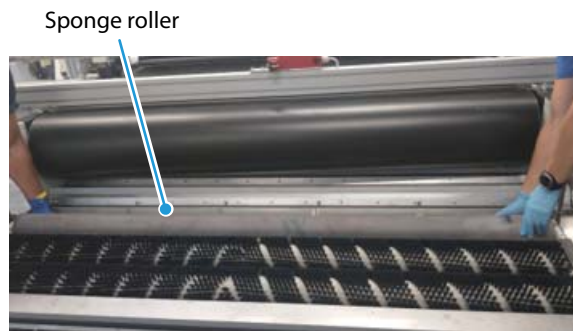

#### 5 Remove the bearings from both ends of the sponge roller.

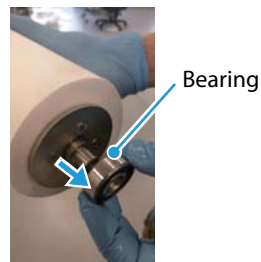

After the bearings are removed, store them in a safe location so that they are not dropped or lost.

#### 6 Remove the four screws on the side where the sponge is screwed on, and then remove the sponge roller plate.

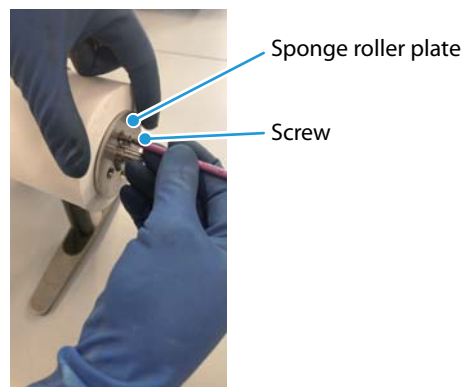

- 7** Pull out the sponge roller shaft from the sponge roller.

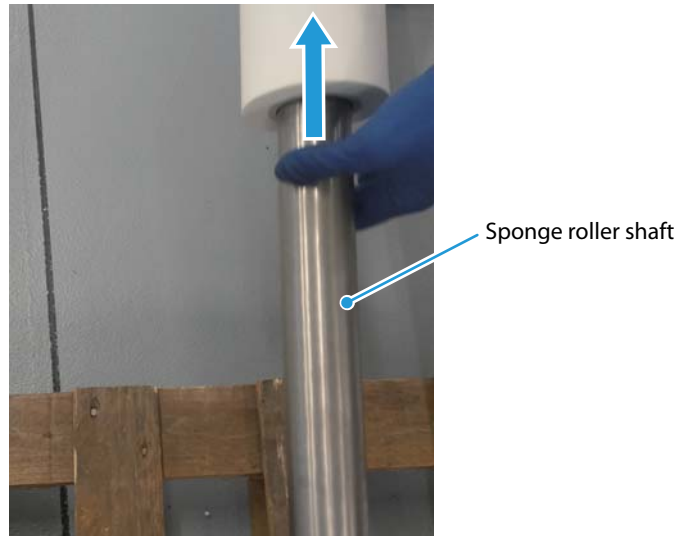

- 8** Insert the new sponge onto the sponge roller shaft from the right angle edge, and insert it until it contacts the flange.

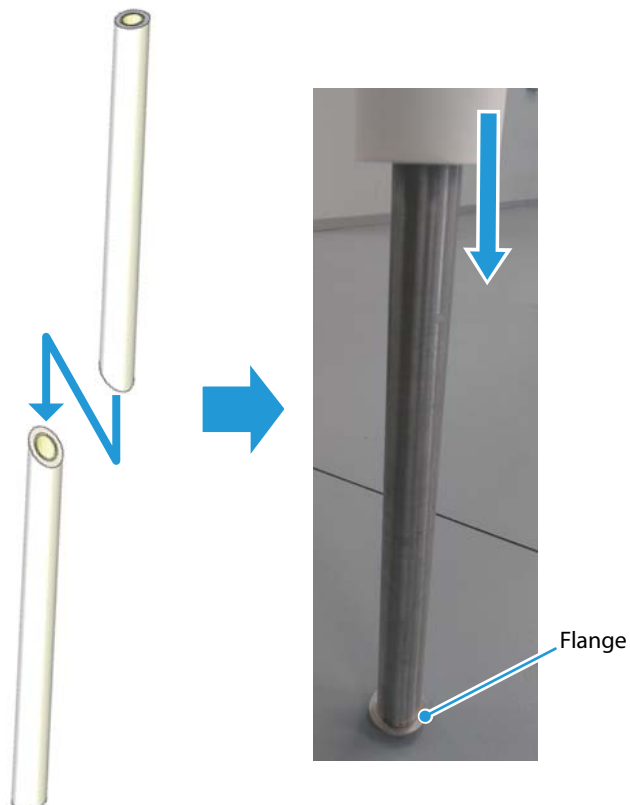

- 9** Insert the second sponge from the slanted edge onto the sponge roller shaft, and push it in adjusting the angle so that there is no gap between the second sponge and the first sponge.



If there is a gap between the sponges, you may not be able to install the belt cleaning unit.

- 10** Install the sponge roller plate on the sponge roller and secure it with four screws.
- 11** Insert the bearings at both ends of the sponge roller.
- 12** Place the sponge roller in the sponge roller tank.
- 13** Fill the sponge roller tank with tap water so that the sponge roller is completely submerged, and keep it submerged for eight hours.
- 14** Remove the sponge roller from the sponge roller tank and install it on the belt cleaning unit.
- 15** Return the belt cleaning unit to the carriage rail.
- 16** Push the belt cleaning unit to the original position. Then tighten the screw on the fastener at two locations with the hex key (width: 6 mm).



Insert the belt cleaning unit straight in its original position.

If it is inserted at an angle, the belt cleaning unit position sensor in the left rear will be unable to detect it, and therefore the emergency stop status may not be released.

Belt cleaning unit position sensor



**17** Turn the left drain valve in the direction of the arrow to open it.

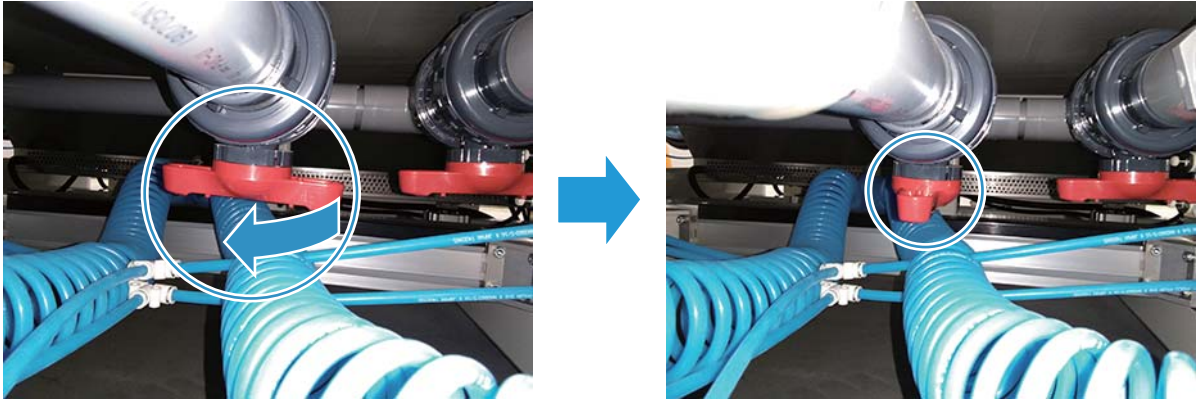

This completes the work.

## Pressure Roller Replacement

Frequency	When necessary
User Permissions	L
Personal Protective Equipment	Protective gloves and clothing
Required Number of Workers	2
Required Items	Replacement pressure roller (sold separately)

- 1 Check that the machine is in the Power Off Status.**  
(For more information, refer to ["Power Off Status" on Page 10.](#))
- 2 Move the pressure roller switch to the right side to move the pressure roller toward you and stop it.**
- 3 Move the pressure roller switch to the left side to raise the pressure roller.**



- 4 Press the emergency stop button.**
- 5 Close the Leonardo screen and shut down the control PC.**
- 6 Turn the main power switch to 0 (OFF) to turn the power off.**
- 7 Open the rear cover.**

## 8 Insert the stopper pins on both sides.



### CAUTION

Make sure that the machine's power is off before performing work.

Right side



Pin

Left side

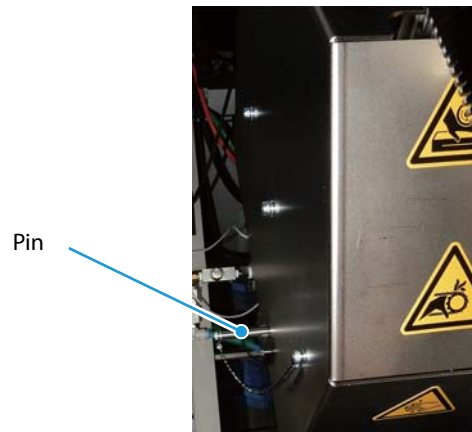

Pin

## 9 Lift the pressure roller vertically to remove it.



### CAUTION

Make sure that removal and installation of the pressure roller is performed by two workers due to the weight of the roller.

When lifting a pressure roller, lift with your legs and not your back.



- 10** From the removed pressure roller, remove the two bearings and replace them.
- 11** Attach a new pressure roller.
- 12** Remove the stopper pins on both sides.
- 13** Close the rear cover.
- 14** Turn the main power switch to 1 (ON) to turn the power on.
- 15** Start up Leonardo.
- 16** Release the emergency stop button.
- 17** Execute Set point.  
Performing Set point causes the pressure roller to automatically come down.





This completes the work.

# Glue Re-Application



## Glue Removal









To remove glue, first pour the remover from the rear of the machine to dissolve the glue, and then scrape glue away from the front of the machine.

This section describes the procedures for using the glue remover recommended by Epson.

Frequency	When the fabric attached to the belt rises slightly. When there is damage such as peeling of the glue.	
User Permissions		
Required Number of Workers	Min. 2 persons	
Personal Protective Equipment	The following is the protective equipment that must be worn when using the glue or glue remover recommended by Epson. For details, refer to the instructions of the SDS for the glue and glue remover you are actually using.	
	Eye protection (For organic solvent use; Optimal is a goggle-type that seals against your face) 	
	Gas mask (For organic solvent use) 	
	Protective gloves (Butyl or polyurethane) 	
	Protective clothing (Long-sleeved)	
	Hair net (Persons with long hair must be tied together with a hair net also worn)	
	Safety shoes	

Required Items		
Item	Quantity	Details
Maintenance key	1	Bundled item
Blade installation part 	2	Bundled item
Cloth rod 	1	Bundled item
Glue collection bucket 	1	Bundled item/ sold separately
Glue-removal felt 	1 sheet	2 sheets bundled. After these are used, use commercially available felt products of the same size: 190 (width) x 45 (length) cm
Glue remover 	Proper amount	Recommended product <ul style="list-style-type: none"> <li>• Cleanser TS (Murayama Chemical Laboratory)</li> <li>• ATR1222 (ATR)</li> <li>• ATR3222 (ATR)</li> </ul>
Ethanol	0.25 L	Commercially available
Bottle (For ethanol) 	1	Commercially available
Hex key (Commercially available) 	1 set	Commercially available

Required Items		
Item	Quantity	Details
Wipe cloths (Fabric for wiping the belt. Use cloths of soft non-fluffy material that will not damage the belt.)		Proper amount Commercially available
Bucket for glue remover		1 Commercially available
Cable ties		Approx. 4 ties Commercially available
Rubber spatula or plastic spatula (a material that does not dissolve in organic solvents)		1 Commercially available
bags or plastic sheets (a material that does not dissolve in organic solvents)		Proper amount Commercially available. Used to protect the belt cleaning unit and electric box.

 <b>CAUTION</b>	
    	<p>Wear eye protection, protective gloves, protective clothing, and respiratory protection when performing these procedures.</p> <p>Check the Safety Data Sheet (SDS) for the glue or remover you will actually use for details, and wear the necessary protective gear.</p>
 	<ul style="list-style-type: none"> <li>• Wear a hat so that your hair does not fall onto the belt.</li> <li>• Long hair should be tied back and worn under a hair net.</li> </ul>

## Preparation

- 1 Check that the machine is in the Printing Standby Status.**  
(For more information, refer to "[Printing Standby Status](#)" on Page 10.)
- 2 Two persons are required to remove the fabric.**  
(For more information, refer to "Setting the Fabric" in the "Operation Guide".)



### CAUTION

Make sure that removal and installation of the fabric roller is performed by two or more workers due to the weight of the fabric.  
When lifting the fabric roll, make sure you bend your knees sufficiently and lift in a natural position.



- 3 Remove the towel roller.**



**4** Remove the fabric edge sensor unit.

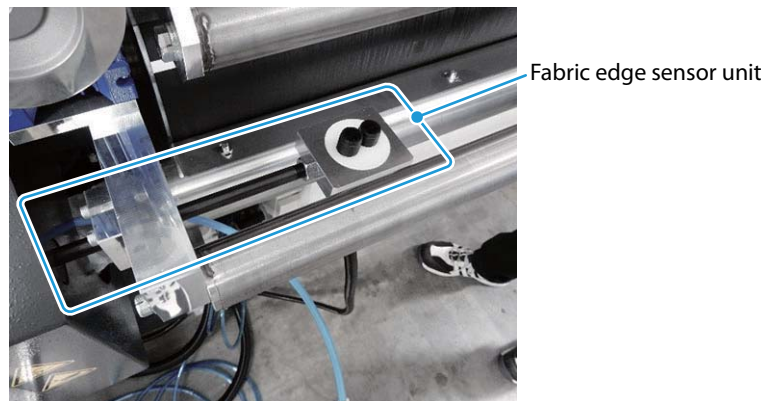

Turn by hand and loosen screw [1] under the sensor unit and remove the sensor unit in direction [2].

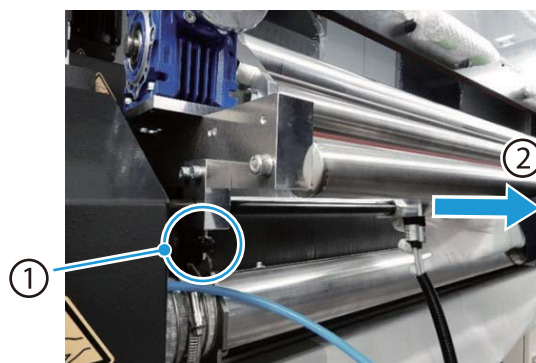

**5** Open the rear cover.

**6** Remove the fabric guide bar.  
Remove the screws on each side of the roller (1 each) using the hex key (width: 6 mm).

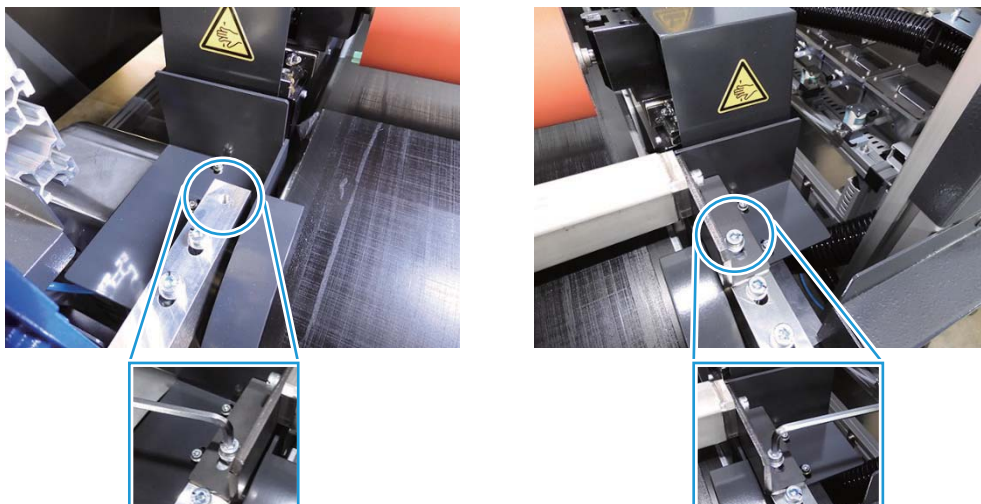

**7** Two persons are required to remove the fabric guide bar.

- 8** Remove the dewrinkling roller.  
Remove the screws on each side of the roller (2 each) using the hex key (width: 5 mm).

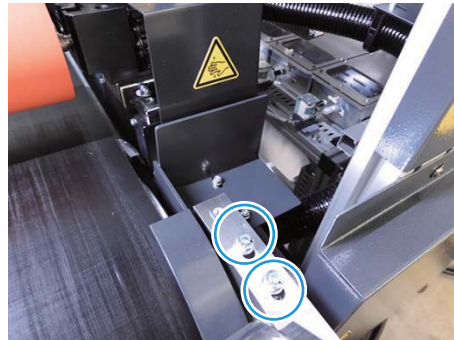

- 9** Two people are required to remove the dewrinkling roller.



- 10** Remove the catching-prevention cover of hair and body parts on the right and left sides of the belt.  
Remove the screws (2 each on left and right) of the catching-prevention cover using the hex key (width: 4 mm).

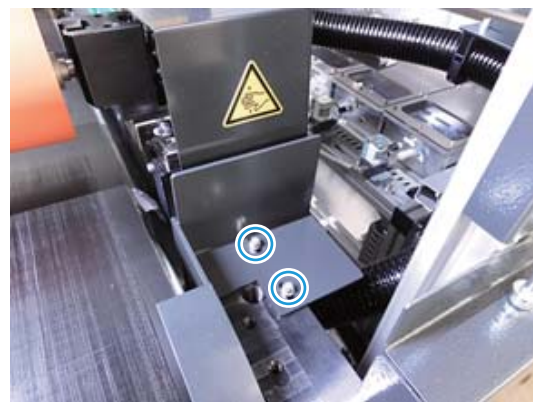
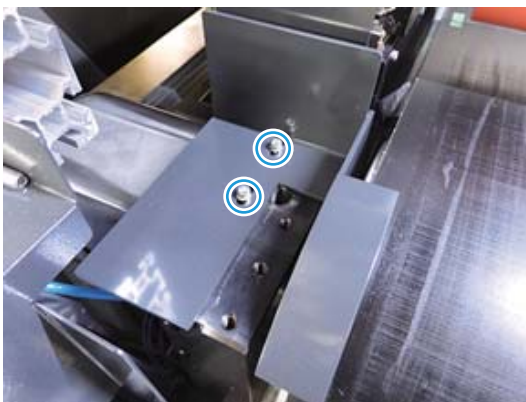

- 11 Use a spanner (width: 7 mm) to loosen the screw on the blower hose, and remove the blower hose from the blower.

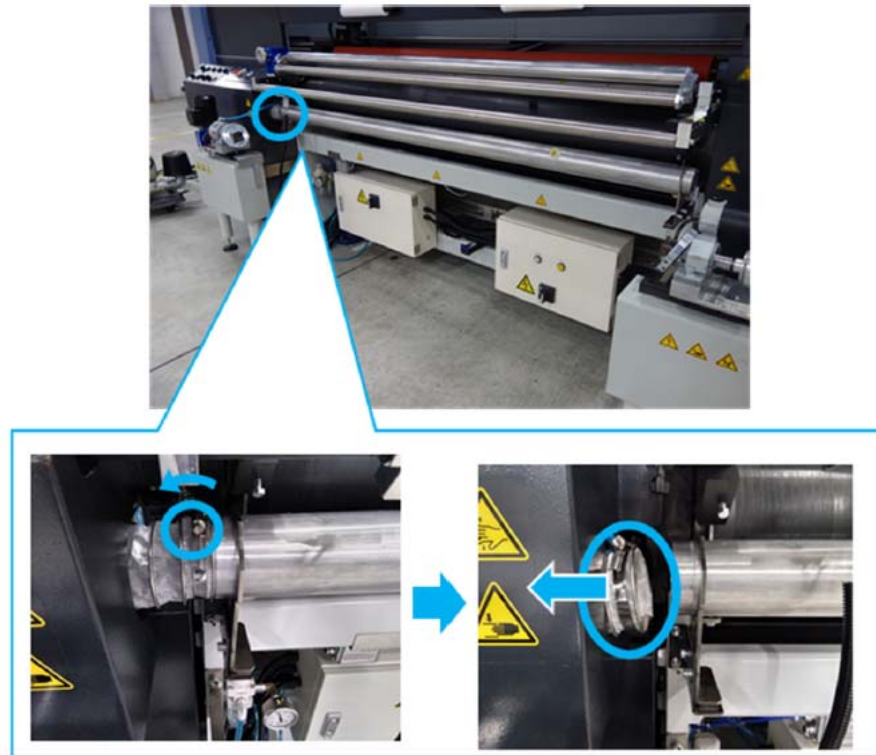

- 12 Loosen and remove the screws on the blower (4 each) using the hex key (width: 5 mm).

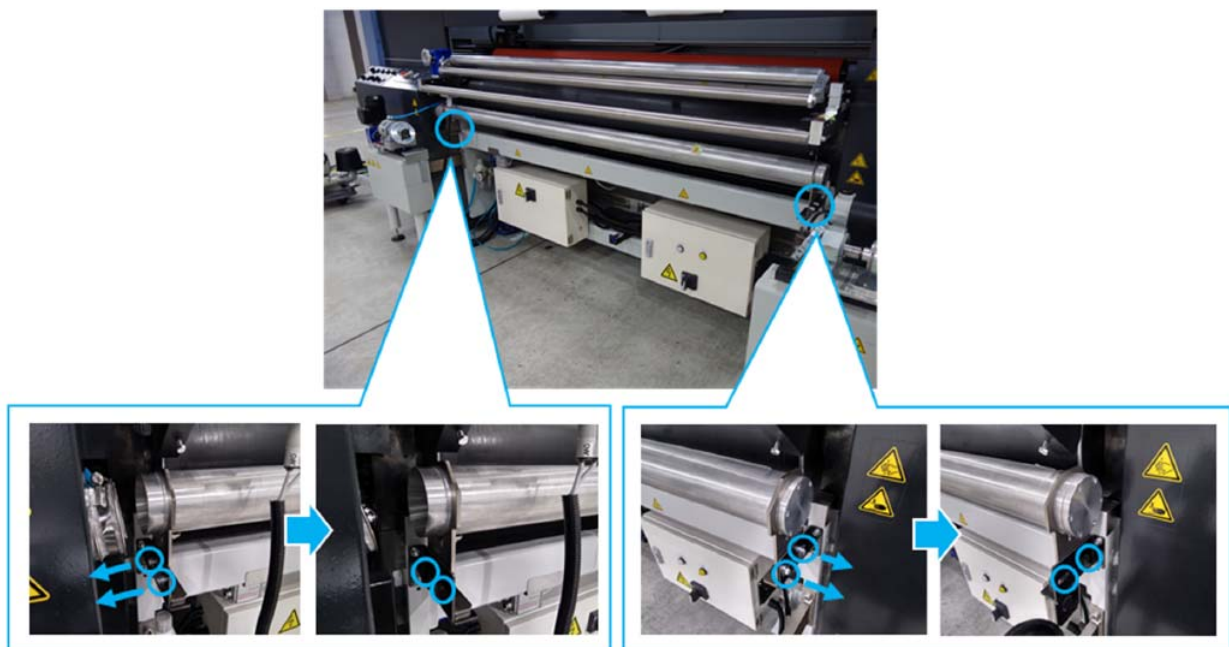

**13** With two persons, pull out the blower toward you and remove it.

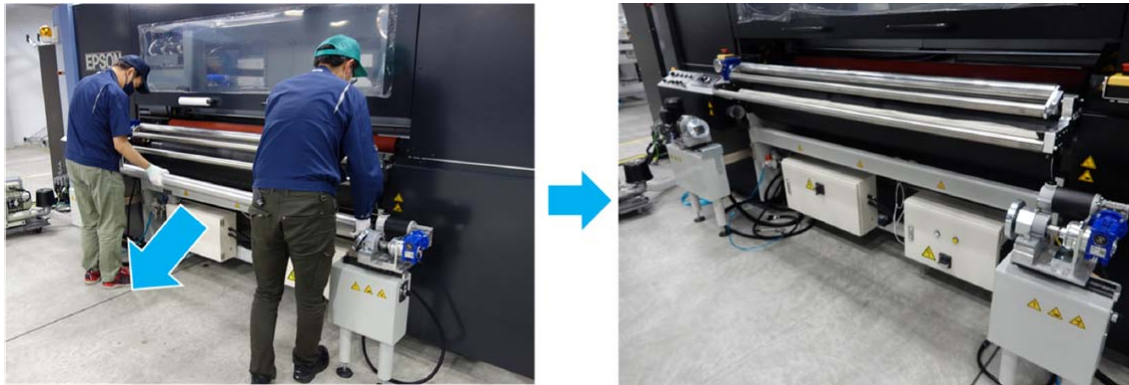

**14** Remove the pressure roller.  
Lift the pressure roller vertically to remove it.



**CAUTION**

Make sure that removal and installation of the pressure roller is performed by two workers due to the weight of the roller.  
When lifting a pressure roller, lift with your legs and not your back.



- 15** Remove the belt holder covers from both sides of the belt.  
Remove the screws (14 each) of the belt holder covers using the hex key (width: 2.5 mm) and remove the covers.

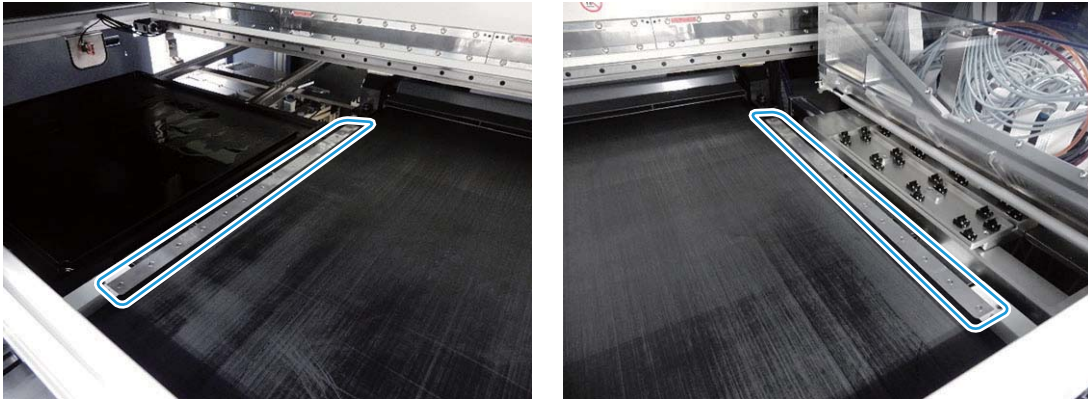

- 16** Use a hex key (width: 4 mm) to remove the screws on the outer left and right sides of the fabric slack prevention unit (2 screws).

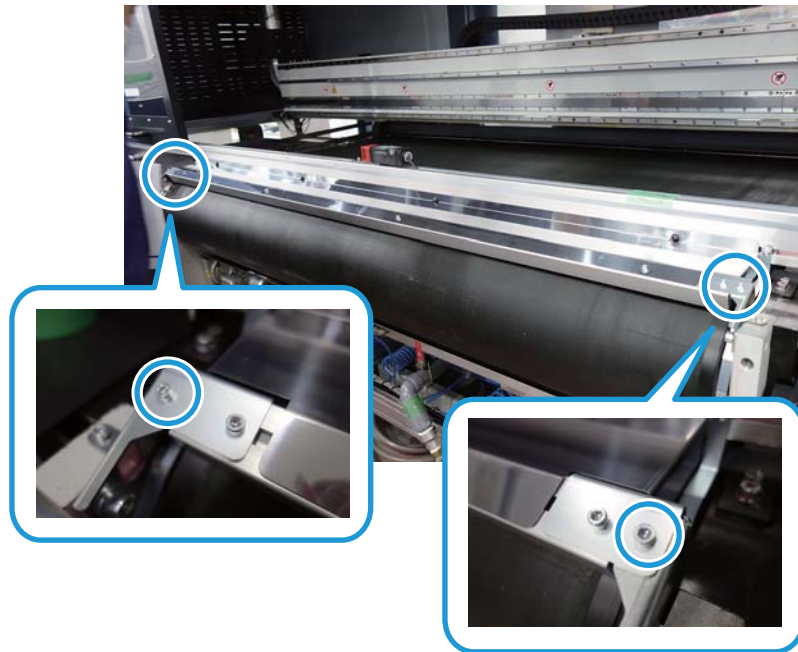

- 17** Use a hex key (width: 4 mm) to loosen the screws securing the fabric slack prevention unit to the front cover frame (4 screws) about half one rotation.

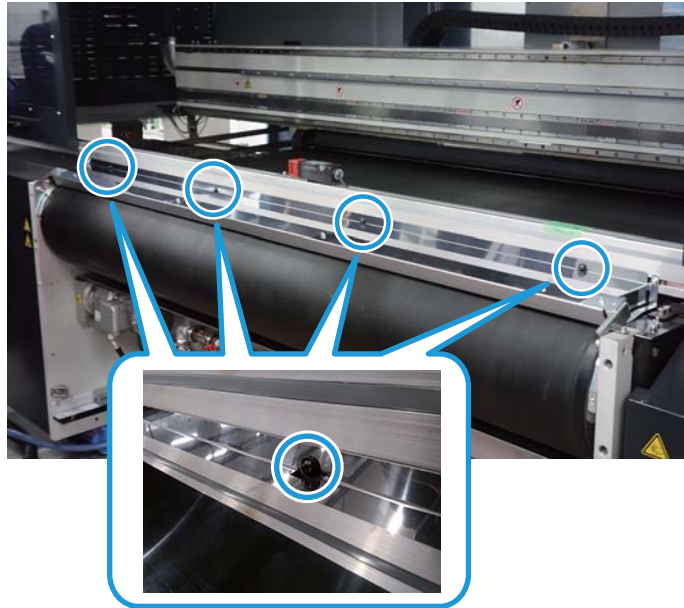

- 18** Remove the fabric slack prevention unit.

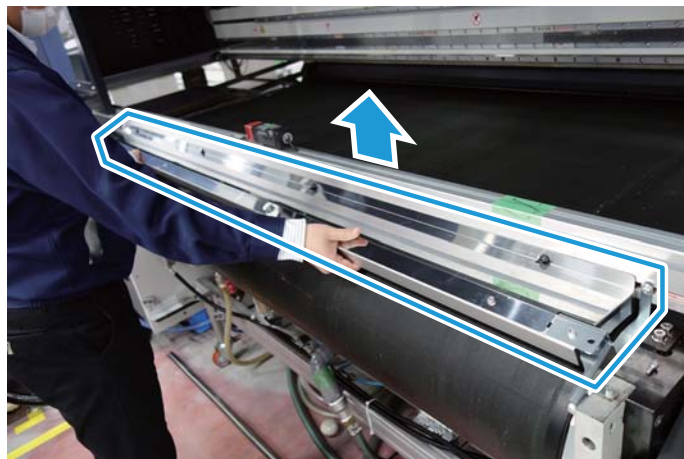

- 19** Pull out the belt cleaning unit.  
Perform steps 1 to 6 in "Replacing the washing T-shaped scraper." For more information, refer to ["Replacing the Washing T-shaped Scraper" on Page 130](#).

**CAUTION**

When you pull out the belt cleaning unit, an emergency stop occurs.

- 20** Cover the belt cleaning unit and the electric box on the underside of the belt in the rear, so they do not become soiled by glue or solvents.  
Example: Cover them with bags or plastic sheets.

- 21** Return the belt cleaning unit to the original position.  
Perform steps 13 and 16 in "Replacing the washing T-shaped scraper." For more information, refer to ["Replacing the Washing T-shaped Scraper" on Page 130.](#)



Insert the belt cleaning unit straight into its original position.

If it is inserted at an angle, the belt cleaning unit position sensor in the left rear will be unable to detect it, and therefore the emergency stop status may not be released.

Belt cleaning unit position sensor



- 22** Move to the rear of the machine, and install the blade installation parts on the right and left.  
Install next to the belt and tighten the screws (1 each on right and left) using the hex key (width: 5 mm).



## 23 Attach the felt to the cloth rod.



When using commercially available felt:  
Sew the ends into bag shapes to make mounting holes, or use cable ties to secure the felt in place after wrapping the felt around the cloth rod.  
Example: Securing the felt with cable ties

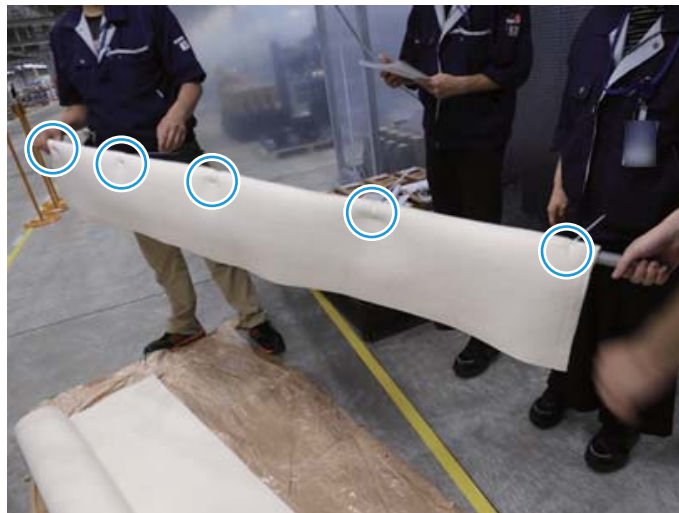

## 24 Place the cloth rod on the belt.



## 25 Secure the cloth rod and blade installation parts with cable ties.

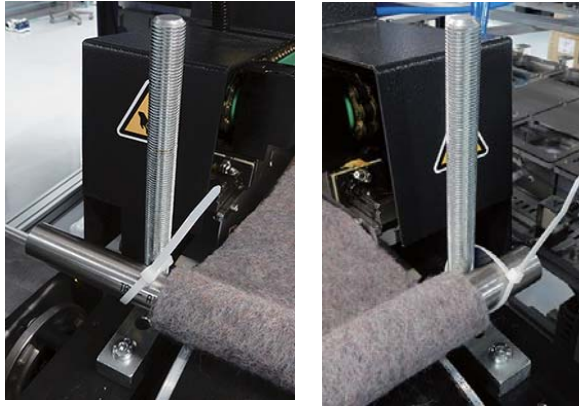

This completes the work.

## Changing Leonardo to Glue Application Mode

Change to glue application mode to rotate the belt continuously. In this mode, you can use the belt speed volume to adjust the belt rotation speed.

- 1 **Start up Leonardo.**
- 2 **Insert the key into the maintenance key switch, and turn it to the right.**  
Leonardo switches to the glue application mode.



### CAUTION

Do not insert the maintenance key except for when applying glue. Inserting the maintenance key disables the belt operation safety function, resulting in a dangerous situation. The key used for the maintenance for glue re-application must be in a safe and locked place and under the full responsibility of the person in charge of.

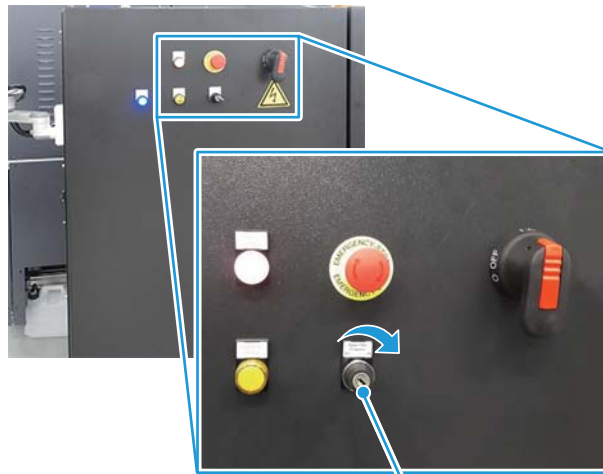

Maintenance key switch

- 3 **Set the scale of the belt speed volume in the rear panel to 0.**



- 4 **Place a check mark in [Feedrate enable] in Leonardo and then click [+].**  
When continuously feeding the belt, you can adjust the feeding speed using the volume in the rear panel.

## Glue Removal

- 1 Turn the main power switch to 1 (ON) to turn the power on.
- 2 Set Leonardo in glue application mode.  
(For more information, refer to ["Changing Leonardo to Glue Application Mode"](#) on Page 158.)
- 3 Pour the glue remover into the glue remover bucket.



### CAUTION

When using the glue remover, wear the personal protective equipment for organic solvent use, such as protective gloves, eye protection, and respiratory protection.

- 4 Soak the felt with an appropriate amount of remover (Guideline: Approx. 2 L for the ML-32000-180/ML-16000-180 and approx. 3 L for the ML-32000-340.).  
Worker 1 (at the rear of the machine): Soak the felt a little at a time so that the remover completely permeates the felt.



- 5 Set the scale of the belt speed volume in the rear panel at 1 to 3, and then rotate the belt in the forward direction.
- 6 Gradually soak with the glue remover until it is uniformly spread.
- 7 The glue on the belt surface begins to dissolve. Make sure that the glue becomes loose and rises slightly along the entire belt.
- 8 When the glue rises slightly along the entire belt, raise the scale of the belt speed volume in the rear panel 3 to 5.
- 9 Start performing glue removal work.  
Worker 2: Take the glue collection basket and move to the front side of the machine.

- 10** Remove the glue from all areas of the belt.  
Worker 1 (at the rear of the machine): To prevent the remover on the surface of the belt from drying, soak the entire surface of the felt with more remover.  
Worker 2 (at the front side of the machine): Securely grasp the handles of the glue collection bucket with both hands and press it against the belt surface to scrape away the glue.



- 11** Worker 2: Once most of the glue has been scraped away, gradually move to the left while scraping away glue from all areas of the belt.  
Worker 1: While checking the scraping conditions, continue pouring an appropriate amount of remover onto the felt.
- 12** After scraping away the glue, if there are any areas with hardened glue remaining, stop the belt and use a wipe cloth to remove it.  
If the hardened glue cannot be easily removed, soak the felt with remover again to make the hardened glue rise, and then scrape it away.



- 13** When all glue has been removed, remove the felt.  
Dispose of the felt in the proper manner for industrial waste.

This completes the work.

## Belt Surface Cleaning

- 1** Confirm that Leonardo is in glue application mode, and then select [Feedrate enable] and click [+] to rotate the belt in the forward direction.
- 2** Use a wipe cloth soaked in ethanol (proper amount) to wipe the belt surface.
- 3** When the belt surface is completely clean, slowly rotate the belt and wipe clean using an ethanol-soaked wipe cloth.



As glue tends to remain on both edges of the belt, focus on wiping off those areas. If glue, tape, or the like is adhering to a belt edge, the belt control unit may not function properly.

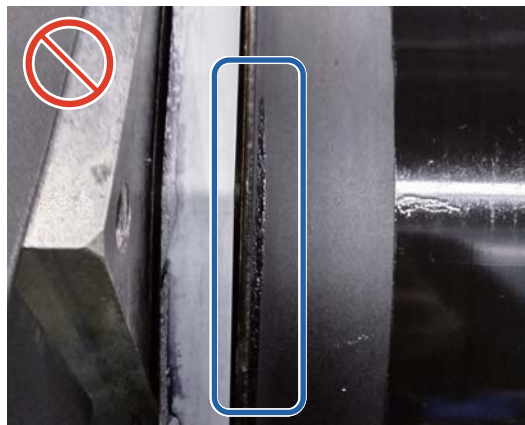

Wipe off the glue until the belt surface has a luster. Be especially careful to remove the glue from both edges of the belt.



## 4 Click [+] on Leonardo to stop the belt.

This completes the work.





### Clean-Up

Use wipe cloths or similar to absorb any waste chemicals, and then dispose of them in the proper manner for industrial waste. Next, apply glue.





For more information, refer to ["Glue Application" on Page 163](#).









# Glue Application

Glue application work is performed at the rear of the machine. This section describes the procedures for using the glue recommended by Epson.

Frequency	When the fabric attached to the belt rises slightly. When there is damage such as peeling of the glue.	
User Permissions		
Required Number of Workers	Min. 2 persons	
Personal Protective Equipment	The following is the protective equipment that must be worn when using the glue or glue remover recommended by Epson. For details, refer to the instructions of the SDS for the glue and glue remover you are actually using.	
	Eye protection (For organic solvent use; Optimal is a goggle-type that seals against your face)	
		
	Gas mask (For organic solvent use)	
		
	Protective gloves (Butyl or polyurethane)	
		
Protective clothing (Long-sleeved)		
Hair net (Persons with long hair must be tied together with a hair net also worn)		
Safety shoes		

Required Items			
Item		Quantity	Details
Blade installation part		2	Bundled item
Blade (For glue application)		1	Bundled item
Glue application blocks		2	Bundled item/ sold separately
Glue bucket		2	Commercially available
Scale		1	Commercially available
Scissors		1	Commercially available
Stirring rod for preparing glue		1	Commercially available
Hex key (Commercially available)		1 set	Commercially available
Glue (1st layer): ATR1945 (ML/T)	ML-32000-180	1.6 kg	Recommended product
	ML-16000-180		
	ML-32000-340	3.0 kg	
Glue (2nd layer): ATR1946 (ML/S)	ML-32000-180	0.8 kg	Recommended product
	ML-16000-180		
	ML-32000-340	1.5 kg	
Glue (2nd layer): ATR1947 (ML/K)	ML-32000-180	0.8 kg	Recommended product
	ML-16000-180		
	ML-32000-340	1.5 kg	

Required Items		
Item	Quantity	Details
Glue remover 	Proper amount	Recommended product <ul style="list-style-type: none"> <li>• Cleanser TS (Murayama Chemical Laboratory)</li> <li>• ATR1222 (ATR)</li> <li>• ATR3222 (ATR)</li> </ul> Used to clean the blade and the accessories.
Ethanol	0.25 L	Commercially available
Bottle (For ethanol) 	1	Commercially available
Insulating tape (thickness: 0.2 mm length:10 m) Width: approx. 25 mm	2	Be sure to use tape with a thickness of 0.2 mm, because this will be the gap between the blade and the belt when applying glue.
Soapy water	Proper amount	Commercially available
Cleaning bottle (For soapy water) 	1	Commercially available
Wipe cloths (Fabric for wiping the belt. Use cloths of soft non-fluffy material that will not damage the belt.) 	Proper amount	Commercially available

 <b>CAUTION</b>	
    	<p>Wear eye protection, protective gloves, protective clothing, and respiratory protection when performing these procedures.</p> <p>Check the Safety Data Sheet (SDS) for the glue or remover you will actually use for details, and wear the necessary protective gear.</p>
 	<ul style="list-style-type: none"> <li>• Wear a hat so that your hair does not fall onto the belt.</li> <li>• Long hair should be tied back and worn under a hair net.</li> </ul>

## Preparation

- 1** Clean the belt surface. Use a wipe cloth soaked in ethanol (proper amount) to wipe the belt surface clean while slowly rotating the belt.  
Wipe off the glue until the belt surface has a luster. Be especially careful to remove the glue from both edges of the belt.



As glue tends to remain on both edges of the belt, focus on wiping off those areas. If glue, tape, or the like is adhering to a belt edge, the belt control unit may not function properly.

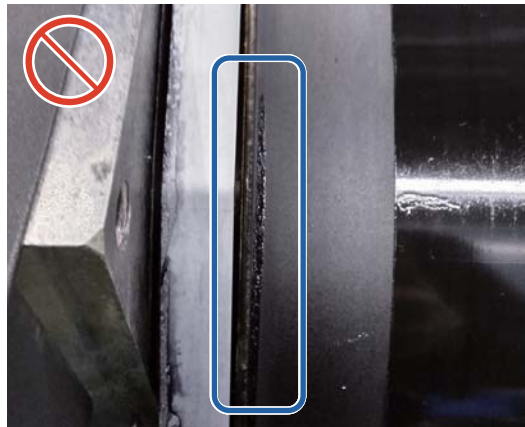

- 2** Dry the belt.  
Set the scale of the belt speed volume in the rear panel to 5, and then rotate the belt in the forward direction for 30 minutes.

- 3** Affix the insulating tape (mending tape) to both edges of the belt. Affix insulating tape completely around the belt. Stop rotating the belt so that the corners of the insulating tape contact the edges of the belt.



- 4** Set the scale of the belt speed volume in the rear panel at 1 to 3, and then slowly rotate the belt in the forward direction so that the tape is affixed completely around the belt.



- 5** Stop rotation of the completely affixed belt and overlap the tape seams by about 5 to 10 mm.

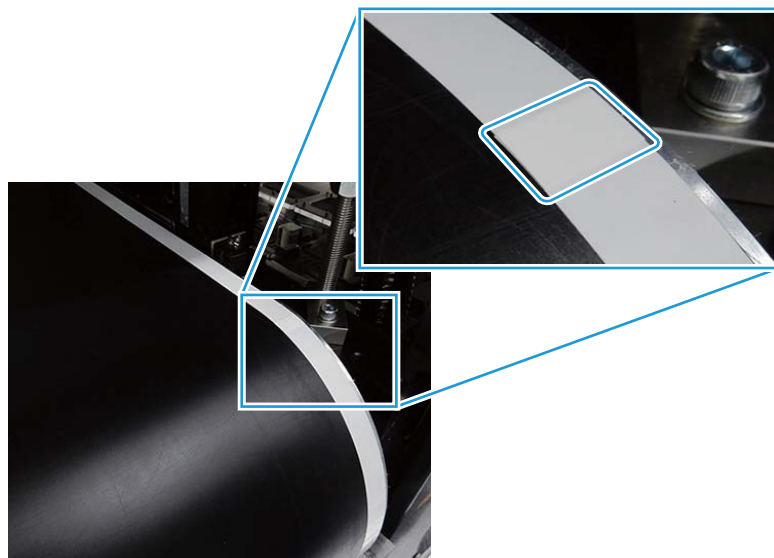

- 6** Slowly feed the belt again while checking there is no foreign material adhering to the belt and remove any that is found.



If the tape is floating up, friction with the blade could cause the tape to tear during glue application.

If the tape tears, the glue cannot be applied uniformly; therefore, the glue must be reapplied.

- 7** Clean the blade.  
Use a wipe cloth soaked in ethanol to wipe off any dirt on the blade.  
If it is extremely dirty, use the glue remover in advance to wipe off the dirt.



**CAUTION**

When using the glue remover, wear the personal protective equipment for organic solvent use, such as protective gloves, eye protection, and respiratory protection.

- 8** Install the blade.  
Two persons are required to carry the blade to the rear of the machine.



Do not place the blade on the floor with the sharp edge facing down, or bump it against other objects. Doing so could damage the sharp edge. A damaged blade will not apply glue uniformly.

- 9** Align the holes on each end of the blade with the supports on the blade installation parts, and slowly and evenly lower the blade on both right and left sides to avoid damaging the belt.

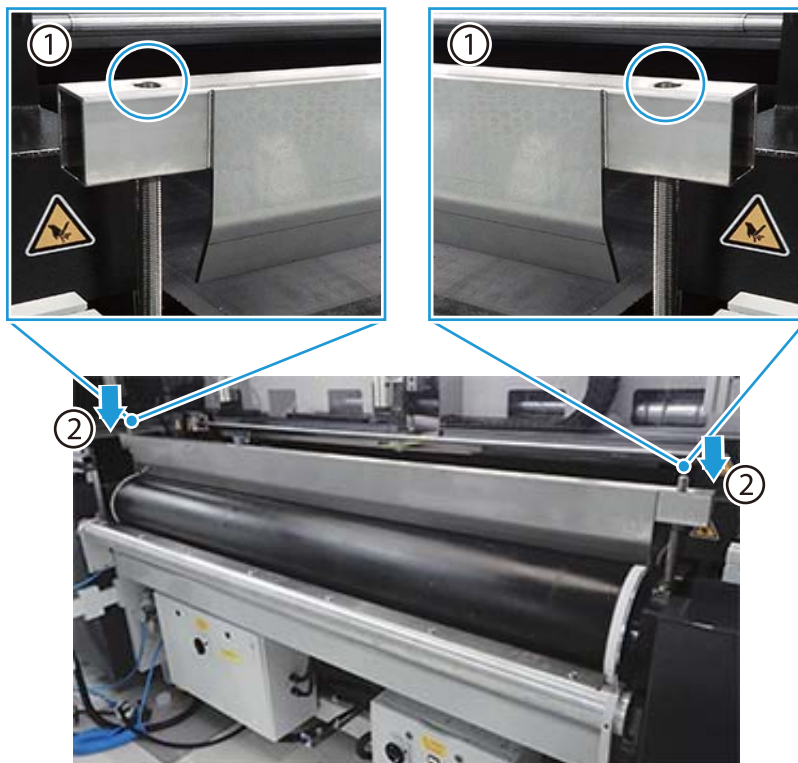

- 10** Rotate the belt a little in the forward direction and stop.  
This operation sets the blade at a slight angle against the belt. This completes the blade installation procedure.

- 11** Place one on each end of the belt so that they are aligned with the edge of the blade. When placing the blocks, do not place them on the seams of the insulating tape applied to both sides of the belt. If the seams of the insulating tape come where you want to place the blocks, feed the belt to where there are no seams.

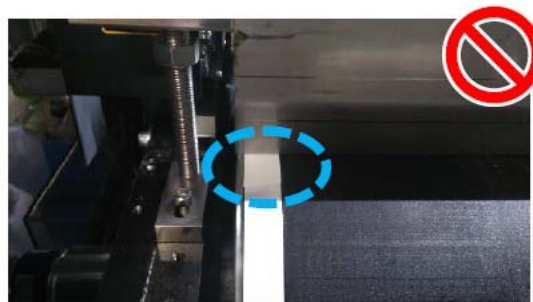

## 12 Affix the glue application blocks to both ends of the blade using insulating tape so that there are no gaps in the following:

- Between the block and the belt
- Between the block and the blade



**CAUTION**

Do not affix the blocks in the states described below. There is a risk that the glue may not be applied evenly, or the glue may leak from the belt edge into the machine, causing a malfunction.

There is a gap between the block and the belt.



There is a gap between the block and the blade.





The block is slanted.



This completes the work.

## Glue Preparation

- 1 Prepare the glue for the first layer.**  
**Set the glue bucket on the scale and pour in the glue (ATR1945 (ML/T)).**

 <b>CAUTION</b>	When using the glue, wear the personal protective equipment for organic solvent use, such as protective gloves, eye protection, and respiratory protection.
	Pour glue into the bucket slowly along the bucket side, to avoid the glue forming bubbles in the bucket.

- 2 Mix the two glue types to prepare the 2nd-layer glue.**  
**Set a glue bucket different from step 1 on the scale and pour in the second glue type (ATR1946 (ML/S)).**  
**Pour in the third glue type (ATR 1947 (ML/K)) and blend them together using the rod.**

	Mix the glue slowly to avoid the glue forming bubbles in the bucket.
---	--

## Glue Application (1st Layer)

- 1** Rotate the belt in the forward direction.  
Set the scale of the belt speed volume in the rear panel at 4 to 6, and then rotate the belt in the forward direction.
- 2** Apply the 1st-layer glue. Pour a proper amount of glue to right next to the blade.  
Pour so that the glue flows from the center to both edges.



It is not necessary to pour all of the glue at once.

As the glue accumulates in front of the blade, rotate the belt to apply glue slowly to the belt surface through the gap between the blade and belt. As the glue decrease, pour in a proper amount of more glue. As the glue decrease, pour in a proper amount of more glue.

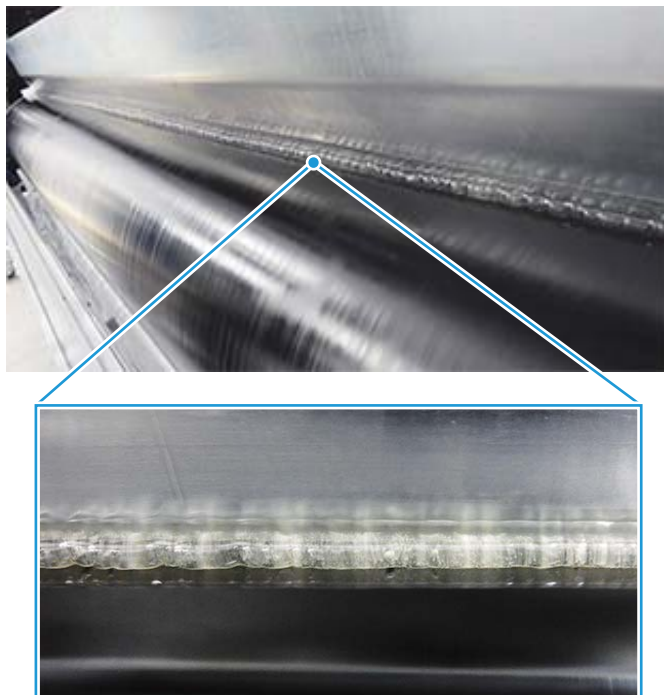

- 3** When the 1st-layer glue has been completely poured in, prepare the 2nd-layer glue.

## Glue Application (2nd Layer)

- 1** Maintain the belt rotation speed as it is, and when the 1-layer glue has nearly all been used, pour the 2nd-layer glue.



Pour the second layer of glue before the first layer has all been used.

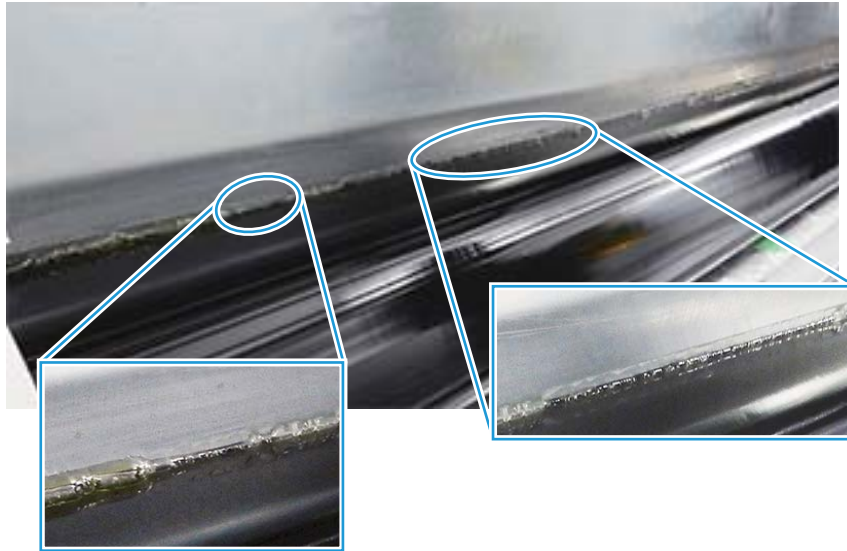

It is not necessary to pour all of the glue at once. Pour a small proper amount of time to the same area as the 1st layer.



- 2** After it has been completely poured, prepare the soapy water, and gradually pour the soapy water above the belt before locations where the 2nd-layer glue has nearly all been used.

The soapy water creates a water repellent membrane on the belt surface so that the glue and blade can be easily separated.

Repeat this procedure until the glue is completely used.



- 3** Check that the glue accumulated in front of the blade has been completely used and soapy water is completely applied.

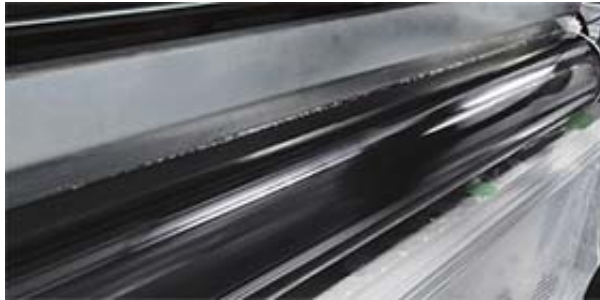

This completes the work.

## Blade Removal

- 1 Two persons are required to lift the blade evenly on both right and left sides, and remove it.



Be careful that the blade does not contact the belt surface when removing it.

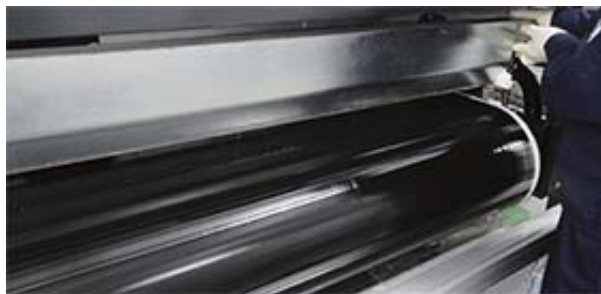

- 2 Wipe the blade, glue application blocks, and glue buckets clean using ethanol. If the dirt cannot be removed, soak a wipe cloth in glue remover to wipe off any glue.



### CAUTION

When using the glue remover, wear the personal protective equipment for organic solvent use, such as protective gloves, eye protection, and respiratory protection.

- 3 Use wipe cloths or similar to absorb any waste solvents, and then dispose of them in the proper manner for industrial waste.

This completes the work.

## Drying

- 1** Set the scale of the belt speed volume in the rear panel to 10, and then rotate the belt in the forward direction for 2 hours.
- 2** Set the scale of the volume in the rear panel to 0 and then stop the rotation of the belt.
- 3** Click [+] in Leonardo.



### CAUTION

Do not insert the maintenance key except for when applying glue. Inserting the maintenance key disables the belt operation safety function, resulting in a dangerous situation. The key used for the maintenance for glue re-application must be in a safe and locked place and under the full responsibility of the person in charge of.

- 4** Allow to dry for 8 hours or more.

This completes the work.

## Work After Application

- 1 After application, leave for 8 hours or more, and then remove the insulating tape. Standing in front of the machine, peel off the insulating tape from the end, and hold the tape while slowly rotating the belt in the forward direction to completely remove it.

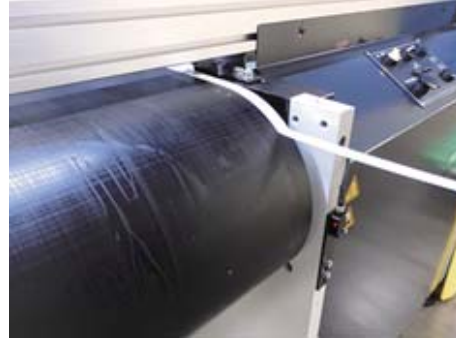
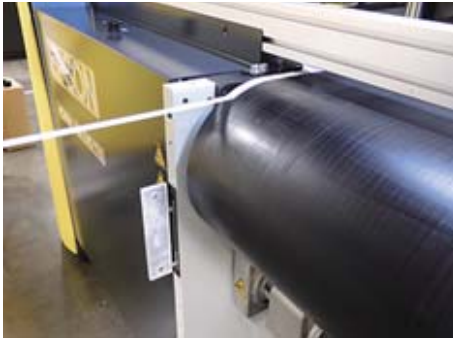

- 2 Check the entire belt for any foreign material.
- 3 Stop the belt, and then cancel glue application mode in Leonardo.



### CAUTION

The maintenance key should be managed by someone who has been authorized by the person in charge at the company. Do not leave it inserted in the keyhole on the main electric box. The person in charge is responsible for storing the maintenance key in a safe, locked location.

- 4 Close the Leonardo screen and shut down the control PC.
- 5 Turn the main power switch to 0 (OFF) to turn the power off.
- 6 Attach the belt holder covers.  
Attach the belt holder covers, and tighten the screws (14 each) using the hex key (width: 2.5 mm).
- 7 Pull out the belt cleaning unit.  
Perform steps 1 to 6 in "Replacing the washing T-shaped scraper." For more information, refer to ["Replacing the Washing T-shaped Scraper" on Page 130](#).





### CAUTION

When you pull out the belt cleaning unit, an emergency stop occurs.

- 8 Remove the protection material (bags or plastic sheets) from the belt cleaning unit and electric box.  
If there is any organic solvent adhered to the protection material, dispose of the protection material in the proper manner for industrial waste.

- 9** Return the belt cleaning unit to the original position.  
 Perform steps 13 and 16 in "Replacing the washing T-shaped scraper." For more information, refer to ["Replacing the Washing T-shaped Scraper" on Page 130.](#)

	<p>Insert the belt cleaning unit straight into its original position.                  If it is inserted at an angle, the belt cleaning unit position sensor in the left rear will be unable to detect it, and therefore the emergency stop status may not be released.</p> <p style="text-align: center;">Belt cleaning unit position sensor</p> 
---	--

- 10** Fit the groove on the fabric slack prevention unit into the gap between the front cover frame and the screws.

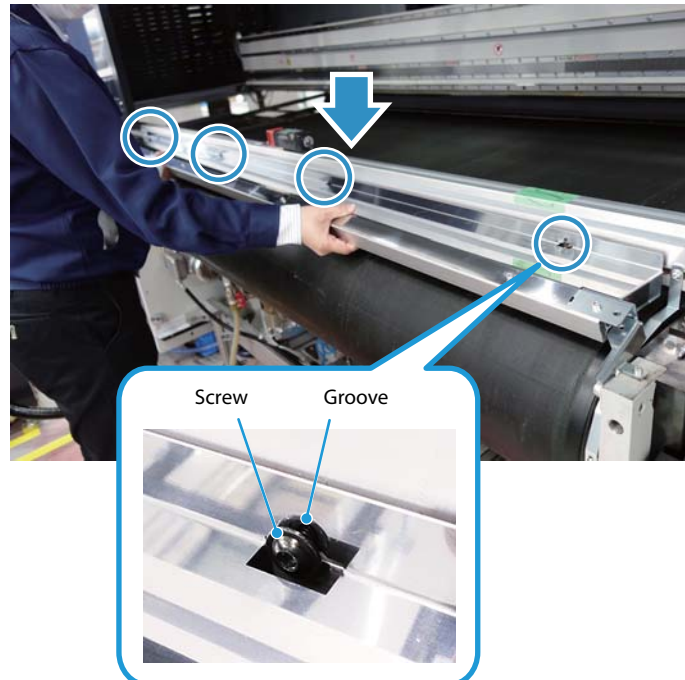

- 11** Use a hex key (width: 4 mm) to tighten the screws on the front cover frame (4 screws).

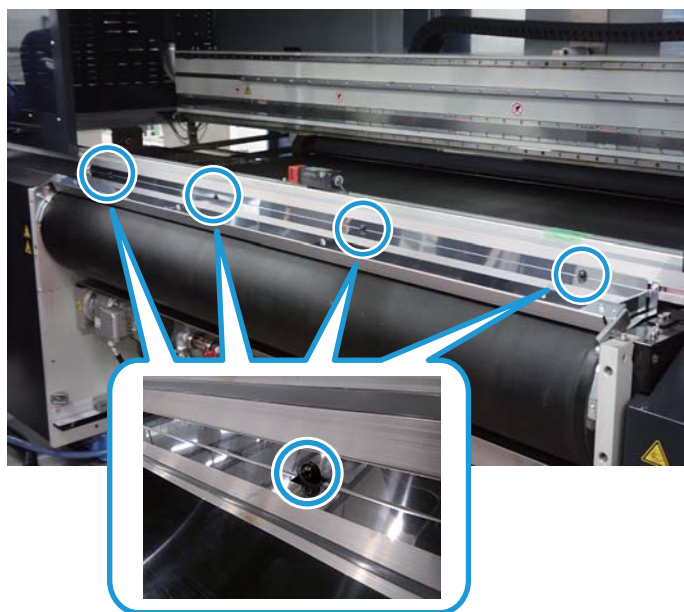

- 12** Use a hex key (width: 4 mm) to tighten the screws on the left and right sides of the fabric slack prevention unit (2 screws).

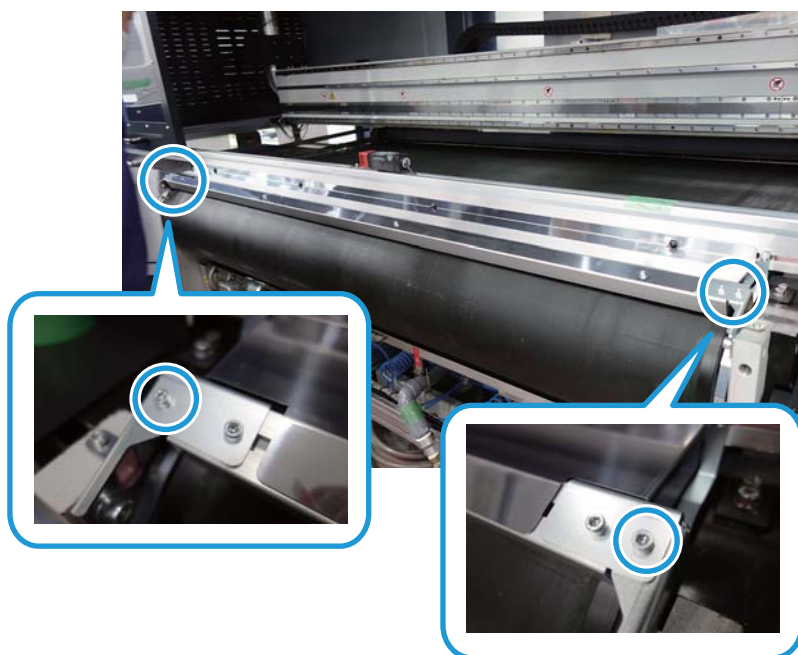

- 13** Install the catching-prevention covers of hair and body parts on the right and left sides of the belt.
- 14** Move to the rear of the machine, and remove the blade installation parts.  
Loosen the screws (1 each on right and left) using the hex key (width: 5 mm) to remove them.
- 15** Install the catching-prevention covers of hair and body parts on the right and left sides of the belt.  
Install the catching-prevention covers, and tighten the screws (2 each on right and left) using the hex key (width: 4 mm).
- 16** Two persons are required to install the pressure roller.

**CAUTION**

Make sure that removal and installation of the pressure roller is performed by two workers due to the weight of the roller.  
When lifting a pressure roller, lift with your legs and not your back.

- 17** With two people, place the blower as indicated in the figure, with the connecting port for the blower hose on the rear left side.



Connecting port for the blower hose



**18** Align the screw holes on the blower and the screw holes on the machine as indicated in the figure.

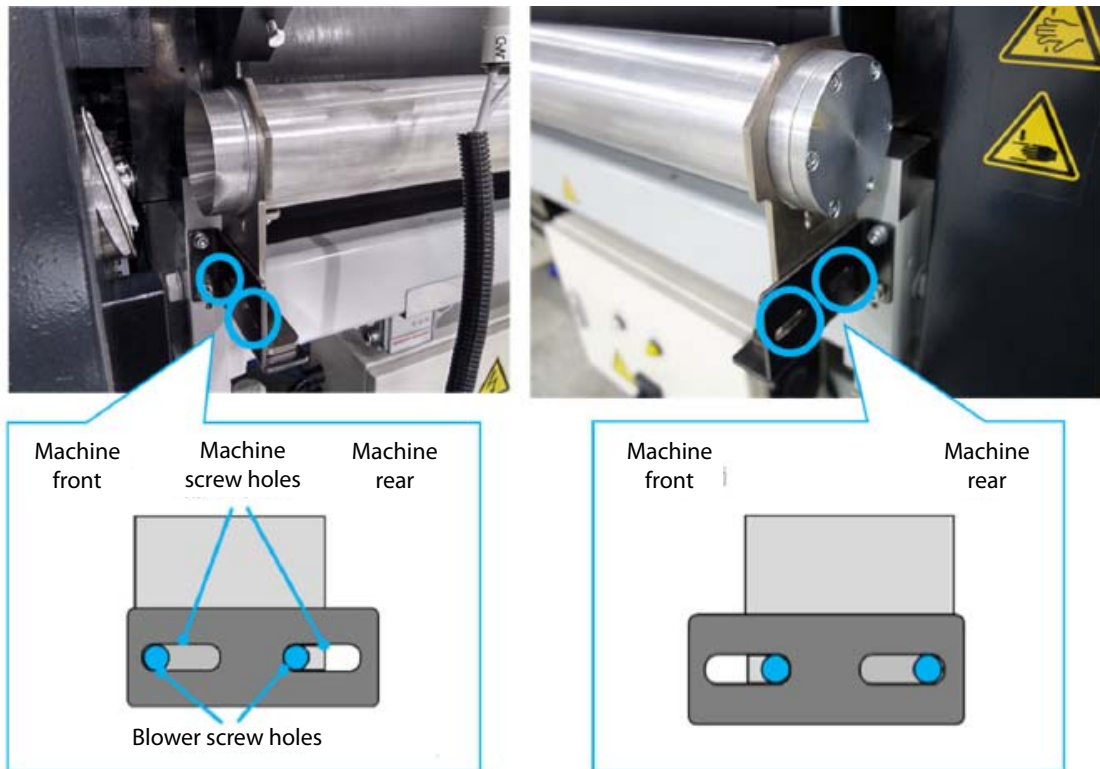

**19** Tighten the screws on the blower (4 each) using the hex key (width: 5 mm).

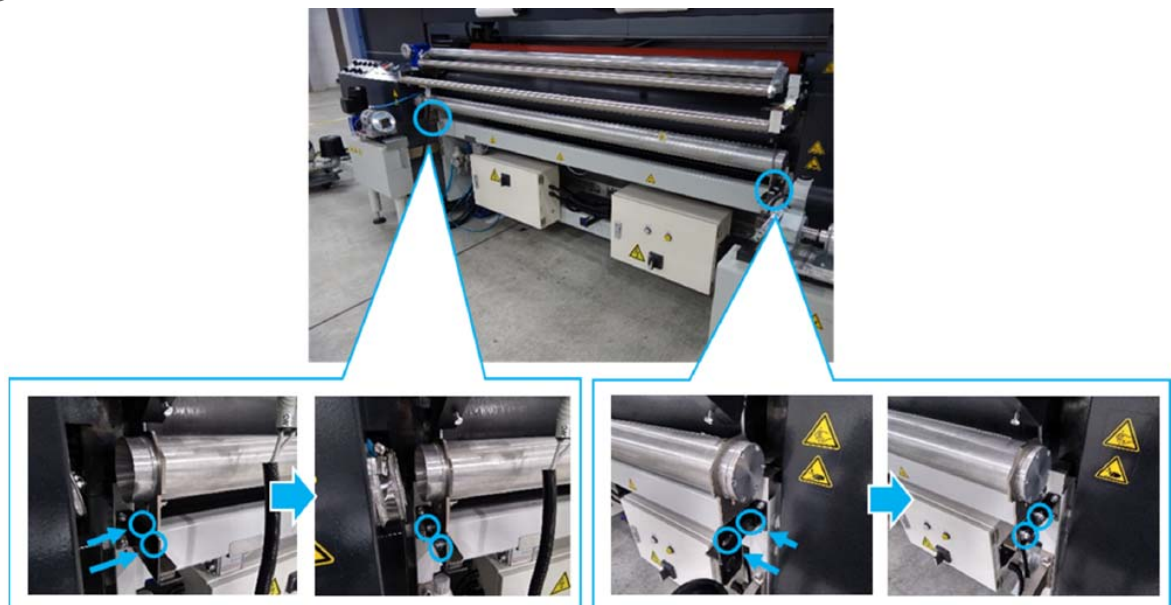

**20** Cover the blower with the blower hose, up to the position indicated in the figure.



- 21** Use a spanner (width: 7 mm) to tighten the screw on the blower hose.

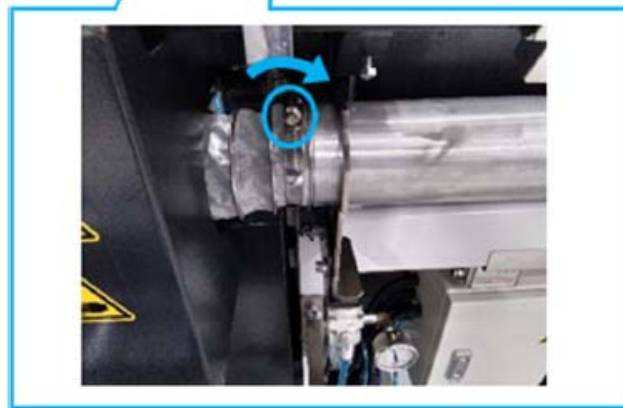

- 22** Attach the dewrinkling roller.  
Use two persons to attach the dewrinkling roller in the original position. Tighten the screws on each side of the roller (1 each) using the hex key (width: 5 mm).
- 23** Attach the fabric guide bar.  
Use two persons to attach the fabric guide bar in the original position. Tighten the screws on each end of the roller (1 each) using a spanner (width: 13 mm).
- 24** Attach the fabric edge sensor unit.  
Return the sensor unit to the original position, and tighten the screw on the bottom of the sensor unit by hand.
- 25** Use two persons to attach the fabric.  
(For more information, refer to "Setting the Fabric" in the "Operation Guide".)

**CAUTION**

Make sure that removal and installation of the fabric roller is performed by two or more workers due to the weight of the fabric.  
When lifting the fabric roll, make sure you bend your knees sufficiently and lift in a natural position.

## **26** Close the rear cover.

This completes the work.