

ML-16000-340 / ML-32000-240 ML-32000-180 / ML-16000-180 Operation Guide

Specifications

Name and Function of Each Part

Workflow before Beginning Work

Print Workflow

Workflow When Turning Off the Power

When Not Using the Printer

Troubleshooting



Cautions

- No part of this document may be reproduced, stored in a retrieval system, or transmitted in any form or by any means, electronic, mechanical, photocopying, recording, or otherwise, without the prior written permission of Seiko Epson Corporation.
- The contents of this document are subject to change without notice. Please contact us for the latest information.
- While every precaution has been taken in the preparation of this document, Seiko Epson Corporation assumes no responsibility for errors or omissions.
- Neither is any liability assumed for damages resulting from the use of the information contained herein.
- Neither Seiko Epson Corporation nor its affiliates shall be liable to the purchaser of this product or third parties for damages, losses, costs, or expenses incurred by the purchaser or third parties as a result of: accident, misuse, or abuse of this product or unauthorized modifications, repairs, or alterations to this product, or (excluding the U.S.) failure to strictly comply with Seiko Epson Corporation's operating and maintenance instructions.
- Seiko Epson Corporation shall not be liable against any damages or problems arising from the use of any options or any consumable products other than those designated as Original EPSON Products or EPSON Approved Products by Seiko Epson Corporation.

Trademarks

Microsoft® and Windows® are either registered trademarks or trademarks of Microsoft Corporation in the United States and other countries.

All other trademarks are the property of their respective owners and used for identification purpose only.

Manual Organization

The manuals for the product are organized as shown below.

The latest manuals are available from qualified service personnel.

- ML-16000-340 / ML-32000-240 / ML-32000-180 / ML-16000-180 Safety Precaution:
This manual explains the safety precautions. Make sure you read this manual to perform operations safely.
- ML-16000-340 / ML-32000-240 / ML-32000-180 / ML-16000-180 Operation Guide:
This manual explains how to use the printer.
- ML-16000-340 / ML-32000-240 / ML-32000-180 / ML-16000-180 Maintenance Guide:
This manual explains how to maintenance the printer.
- Leonardo Reference Guide:
This manual explains how to use the Leonardo.

Images in this Manual

The images used in this manual may differ from your machine.

Unless otherwise stated, this document uses images of the ML-32000-180.

©Seiko Epson Corporation 2021–2024

Before Use

This section explains, describes the symbols that are used both in this manual and on this machine.



Be sure to read this manual and the separate "Safety Precaution" carefully before using this machine. Store this manual in a safe location where it can be easily referred to whenever you have a question.





Meaning of Marks

The following warning symbols are used in this manual and on this machine to indicate hazardous operations, to ensure that this machine is used safely and correctly in order to prevent injury to the user and other persons and damage to property.

Please carefully read and understand these warnings before using this machine.



Symbols in This Manual

 WARNING	This symbol indicates that incorrect operation could result in death or serious injury.
 CAUTION	This symbol indicates that incorrect operation could result in injury and/or damage to property.
	This symbol indicates a supplementary explanation or additional information that the user should know.

				
Indicates actions that must not be taken (prohibited actions).	Indicates actions that must be taken and/or instructions that must be followed.	Do not disassemble	Do not touch	No flames

				
Eye protection must be worn	Protective gloves must be worn	Protective clothing must be worn	Respiratory protection must be worn	Hair net must be worn

User Permissions

	<p>This symbol indicates user permissions for general users who have been trained in the operation of the machine, to perform machine normal operation, cleaning, and simple maintenance procedures while protective devices are engaged and using the button panel.</p> <p>"L" profile to the person assigned to normal operation of the machine.</p>
	<p>This symbol indicates user permissions for general users who have been officially trained in the operation of this machine, to perform some functions and maintenance procedures that are allowed in addition to all of the functions for L.</p> <p>"H" profile to the person assigned to the periodic supervising operations, who holds the activation keys for the selectors and is authorized to occasionally operate the jog controls.</p> <p>The user is required to acquaint the operators about the information contained in this manual and to always have the manual accessible for reference.</p> <p>The same is true for the operators assigned to checks and maintenance, both routine or extraordinary and only if qualified by specific Epson training.</p> <p>Operators are required to understand and adhere to company safety rules, general accident prevention standards, and health and safety regulations.</p> <p>It is the responsibility of the user to assign personnel to run and/or maintain the machine who are suitable both physically, mentally, and professionally for the tasks and responsibilities involved in each.</p> <p>In particular, for personal and general safety, the machine must absolutely never be operated by people with abnormal reaction times because of their intake of medicines or similar substances, or because of physical defects that slow their movements.</p> <p>It is strongly recommended to make all operators aware of their responsibilities when running the machine. For that purpose, it is also important to collect their recommendations, complaints, and suggestions, as well as all notations on any anomalies that may occur.</p>

Contents

- Before Use.....3
 - Meaning of Marks3
- Contents.....5

Specifications 9

- Basic Specifications9
 - ML-16000-180/ ML-32000-1809
 - ML-32000-240.....10
 - ML-16000-340.....11
- Resolution/Number of Passes and Print Speed..... 12
 - ML-16000-180.....12
 - ML-32000-180.....14
- Printing Width..... 16
- Power..... 17
 - ML-16000-180/ ML-32000-18017
 - ML-32000-240.....19
 - ML-16000-340.....21
- Supported Ink..... 23
 - Supported Ink (3L)23
 - Supported Ink (10L).....26
- Ink Cartridges 29
 - Ink Cartridges (3L).....29
 - Ink Cartridges (10L)30
- Consumables 31

Name and Function of Each Part32

- Name of Each Part..... 32
- Ink Rack (3L) 38
 - Inside of Ink Tank.....39
- Ink Rack (10L)..... 40
- Control Panel 42

Workflow before Beginning Work.....47

- Workflow..... 47
- Supplying and Adjusting Compressed Air 48

■ Removing the Stopper Pin of the Pressure Roller.....	50
■ Lowering the Towel Roller	51
■ Supplying Water to the Belt Cleaning Unit	53
Opening the Water Supply Valve.....	53
■ Prepare the Fabric.....	54
■ Adjusting the Fabric Peeling Prevention Bar	55
■ Checking Operating Parts	58
■ Checking the Exhaust Equipment	59
■ Pushing an Emergency Stop Button for an Emergency Stop	60
■ Turning On the Power	60
■ Starting Leonardo.....	61
■ Releasing an Emergency Stop Button.....	62
■ Executing Setpoint	63
■ Checking the Operation of the Emergency Stop Equipment.....	64
Checking the Emergency Stop Buttons on the Machine.....	64
Checking the Emergency Stop Functions in the System.....	64
■ Inspecting for Leaks in the Ink Path	65
■ Inspecting the Open Cover Detection	66
■ Nozzle Check.....	67
Setting the Acrylic Board.....	67
Printing the Nozzle Check Pattern	68
Confirmation Method.....	69
■ Head Cleaning	70
Cleaning with Leonardo	70
<hr/>	
<i>Print Workflow</i>	<i>72</i>
■ Workflow.....	72
■ Setting the Fabric.....	73
Loading the Fabric	73
Dewrinkling the Fabric.....	81
Slack Mode	82
Fabric Meandering Correction	88
■ Setting the Foreign Material Detection Sensor.....	94
How to Set the Foreign Material Detection Sensor	95
■ Setting the Printer	97
Set the Fabric Thickness and Head Height.....	97
Set the Printer Equipment and Sensors	99
■ Loading the Print Data	100
■ Setting the Print Data.....	102

■ Printing	104
Checking the Status of the Fabric	104
Checking the Towel Roller.....	104
Checking the Print Path	104
Checking the Ink.....	104
Configuring the Print Settings.....	104
Printing	105
Checking the Cleaning Unit	105
Printing Ends.....	105
■ Stopping Printing	106
■ Replace the Ink	107
Checking the Amount of Ink.....	107
Replace the Ink (3L)	108
Replace the Ink (10L).....	115
■ Changing User Permissions	119
■ Checking the Belt Cleaning Unit Operation	120

***Workflow When Turning Off the Power*..... 121**

■ Inserting the Stopper Pin of the Pressure Roller	122
■ Lifting Up the Towel Roller	123
■ Cleaning	125
Wipers and Caps	125
Flushing Plate	125
Belt (When Using Pigment Ink).....	125
■ Push an Emergency Stop Button for an Emergency Stop	125
■ Exiting Leonardo	125
■ Turning Off the Control PC	125
■ Turn off the Main Power	126
■ Closing the Water Supply Valve	126
■ Exhausting of Compressed Air	127

***When Not Using the Printer*..... 128**

■ When the Printer will Not Be Used for Two Days to a Week	128
■ When the Printer will Not Be Used for More than One Week	131
■ When Resuming Printing	132

***Troubleshooting*..... 133**

Error Messages	133
Print Quality	137

Manual flushing.....	137
Print Head Failure.....	138

Specifications

This section describes the specifications for the ML-32000-240 / ML-16000-340 / ML-32000-180 / ML-16000-180.

Basic Specifications

ML-16000-180/ ML-32000-180

Item	Specifications		Notes
	ML-16000-180	ML-32000-180	
Printhead	Inkjet		8-color
Compatible inks	Reactive ink, dispersion ink, acid ink, Pigment ink, Ink penetration liquid (acid and reactive use)		
Printing resolution	X: Scanning direction Min. 300 dpi to Max. 1,200 dpi Y: Fabric feed direction 600 dpi, 1,200 dpi		
Print speed	Refer to " ML-16000-180 " on page 12.	Refer to " ML-32000-180 " on page 14.	
Max. printing width	1,800 mm {70.9 in}		
Color number	8-color		
Ink cartridge	1 color/1 pack		
Ink cartridge capacity	3 liters {183 in ³ } or 10 liters {610 in ³ }		
Noise	Less than 80 dB(A)		
Printer operating environment	Temperature: 20 to 30 °C {68 to 86°F} Humidity: 35 to 80 % RH (no condensation)		
Recommended printing environment	Temperature: 22 to 28 °C {71.6 to 82.4 °F} Humidity: 35 to 80 % RH (no condensation)		
Printer storage environment	Store the printer filled with ink. Temperature: 0 to 40 °C {32 to 104 °F} 1 month Must not be any condensation.		
Device dimensions	Printer: 4,610 (W) x 2,040 (D) x 2,065 (H) mm {181 x 80 x 81 in} Main electric box: 1,410 (W) x 627 (D) x 2,268 (H) mm {56 x 25 x 89 in}		Not including the feeding unit, winding device and drying device. Height includes the adjusters and tower lamp.
Equipment weight	Printer: Main electric box:	Approx. 3,700 kg {8,157 lb} Approx. 370 kg {816 lb}	

ML-32000-240

Item	Specifications	Notes
Printhead	Inkjet	8-color
Compatible inks	Reactive ink, dispersion ink, acid ink, Pigment ink	
Printing resolution	X: Scanning direction Min. 300 dpi to Max. 1200 dpi Y: Fabric feed direction 600 dpi, 1200 dpi	
Max. printing width	2400 mm {94.5 in}	
Color number	8-color	
Ink cartridge	1 color/1 pack	
Ink cartridge capacity	10 liters {610 in ³ }	
Noise	Less than 80 dB(A)	
Printer operating environment	Temperature: 20 to 30°C {68 to 86°F} Humidity: 35 to 80 % RH (no condensation)	
Recommended printing environment	Temperature: 22 to 28°C {71.6 to 82.4 °F} Humidity: 35 to 80 % RH (no condensation)	
Printer storage environment	Store the printer filled with ink. Temperature: 0 to 40°C {32 to 104 °F} 1 month Must not be any condensation.	
Device dimensions	Printer: 5,260 (W) x 2,490 (D) x 1,950 (H) mm {207 x 98 x 76.8 in} Main electric box: 1,500 (W) x 660 (D) x 2,270 (H) mm {59 x 26.0 x 89.4 in}	Not including the feeding unit, winding device and drying device. Height includes the adjusters and tower lamp.
Equipment weight	Printer: Approx. 4.300 kg {9.479 lb} Main electric box: Approx. 400 kg {881 lb}	

ML-16000-340

Item	Specifications	Notes
Printhead	Inkjet	8-color
Compatible inks	Reactive ink, dispersion ink, acid ink, Pigment ink	
Printing resolution	X: Scanning direction Min. 300 dpi to Max. 1200 dpi Y: Fabric feed direction 600 dpi, 1200 dpi	
Max. printing width	3,400 mm {133.9 in}	
Color number	8-color	
Ink cartridge	1 color/1 pack	
Ink cartridge capacity	10 liters {610 in ³ }	
Noise	Less than 80 dB(A)	
Printer operating environment	Temperature: 20 to 30°C {68 to 86°F} Humidity: 35 to 80 % RH (no condensation)	
Recommended printing environment	Temperature: 22 to 28°C {71.6 to 82.4 °F} Humidity: 35 to 80 % RH (no condensation)	
Printer storage environment	Store the printer filled with ink. Temperature: 0 to 40°C {32 to 104 °F} 1 month Must not be any condensation.	
Device dimensions	Printer: 6,560 (W) x 2,500 (D) x 1,940 (H) mm {258.3 x 98.4 x 76.4 in} Main electric box: 1,500 (W) x 660 (D) x 2,270 (H) mm {59 x 26.0 x 89.4 in}	Not including the feeding unit, winding device and drying device. Height includes the adjusters and tower lamp.
Equipment weight	Printer: Approx. 6,000 kg {13,227 lb} Main electric box: Approx. 400 kg {881 lb}	

Resolution/Number of Passes and Print Speed

ML-16000-180

* Prerequisites: Bidirectional printing, Print width of 1,500 mm
Print speed differs depending on the images, firmware, PC operating status and print settings.

Resolution		Number of passes	Print speed * (m ² /h)
Scan direction [dpi]	Belt direction [dpi]		
300	600	1 pass	417
	600	2 passes	245
	600	3 passes	162
	600	4 passes	120
	600	4+ passes	112
	1,200	2 passes	236
	1,200	4 passes	123
	1,200	6 passes	81
	1,200	8+ passes	56
600	600	1 pass	284
	600	2 passes	236
	600	3 passes	165
	600	4 passes	123
	600	4+ passes	108
	1,200	2 passes	154
	1,200	4 passes	119
	1,200	6 passes	82
	1,200	8+ passes	54

Resolution		Number of passes	Print speed * (m ² /h)
Scan direction [dpi]	Belt direction [dpi]		
900	600	1 pass	209
	600	2 passes	189
	600	3 passes	158
	600	4 passes	125
	600	4+ passes	87
	1,200	2 passes	112
	1,200	4 passes	95
	1,200	6 passes	79
	1,200	8+ passes	43
1,200	600	1 pass	163
	600	2 passes	154
	600	3 passes	138
	600	4 passes	119
	600	4+ passes	70
	1,200	2 passes	85
	1,200	4 passes	77
	1,200	6 passes	69
	1,200	8+ passes	35

ML-32000-180

- * Prerequisites: Bidirectional printing, Print width of 1,500 mm
Print speed differs depending on the images, firmware, PC operating status and print settings.

Resolution		Number of passes	Print speed * (m ² /h)
Scan direction [dpi]	Belt direction [dpi]		
300	600	1 pass	697
	600	2 passes	434
	600	3 passes	313
	600	4 passes	235
	600	4+ passes	215
	1,200	2 passes	423
	1,200	4 passes	238
	1,200	6 passes	158
	1,200	8+ passes	108
600	600	1 pass	485
	600	2 passes	423
	600	3 passes	317
	600	4 passes	239
	600	4+ passes	208
	1,200	2 passes	286
	1,200	4 passes	232
	1,200	6 passes	161
	1,200	8+ passes	105
900	600	1 pass	374
	600	2 passes	345
	600	3 passes	305
	600	4 passes	244
	600	4+ passes	168
	1,200	2 passes	211
	1,200	4 passes	186
	1,200	6 passes	155
	1,200	8+ passes	84

Resolution		Number of passes	Print speed * (m ² /h)
Scan direction [dpi]	Belt direction [dpi]		
1,200	600	1 pass	302
	600	2 passes	286
	600	3 passes	262
	600	4 passes	232
	600	4+ passes	137
	1,200	2 passes	164
	1,200	4 passes	151
	1,200	6 passes	135
	1,200	8+ passes	68

Printing Width

Item		Specifications
Possible printing area Scan direction (x)	ML-32000-180, ML-16000-180	340 to 1,800 mm {13.4 to 70.9 in}
	ML-32000-240	340 to 2,400 mm {13.4 to 94.5 in}
	ML-16000-340	340 to 3,400 mm {13.4 to 133.9 in}
Margin specifications		No margin
Printing width settings input units		0.1 mm {0.0039 in}

Power

ML-16000-180/ ML-32000-180

Item	Specifications	Notes
Voltage	400 V \pm 10 %, 3-phase + Neutral + Earth	
Frequency	50 / 60 Hz \pm 3 %	
Rated apparent power	20.7 kVA	
Power consumption	Printing Approx. 5.5 kW	
Power consumption (with hot roller option)	Printing Approx. 12 kW	
Rated current	30 A	
Leakage current	300 mA or less	
Factory facilities Connected/Wired	Type: Terminal block connection Connecting part model: Power: CB510 (Manufacturer. by Cabur) Ground: TO210 (Manufacturer. by Cabur) Compatible crimped terminals (reference): Ferrule type WP160/22 Wiring specifications (recommended): 600 V withstand voltage (UL1063 equivalent) Wire size of 10 mm ² (AWG8) or larger	

Factory facilities

Item	Specifications	Notes
Compressed air	Pressure: Min. 0.6 MPa (6 bar) Required air flow capacity: 250 L/min Connector: User: Tube Φ 12 mm (O.D) Machine: Fitting Φ 12 mm	Required for raising/lowering the cleaning tank, ink pressure, etc. Air consumption is the amount of air in an hour. This is used to select compressors. The required air flow capacity is the flow rate which needs to be supplied from factory to the machine within a short period of time. This is used to select the main piping to the machine.
Water	Pressure: 0.4 Mpa (4 bar) - 0.6 MPa (6 bar) Flow rate: Max. 100 Liter/hr {6,102 in ³ /h} Connector: User: Horse + Fitting (R3/4) Machine: Fitting (Rc3/4)	Required for belt cleaning.

Item	Specifications	Notes
Wastewater	Flow rate: Max. 100 Liter/hr {6,102 in ³ /h} Connector: User: Horse + Fitting Machine: PVC pipe nominal diameter 40A (Φ48 mm (O.D))	Required for wastewater for belt cleaning. Users are requested to dispose of wastewater according to local laws and regulations.
Waste liquid	Flushing plate Connector: User: Horse Φ12 mm (I.D) + Band Machine: Fitting Φ14 mm (O.D)	Waste ink is discharged from the flushing plate and cleaning station, and therefore it is necessary to provide a route for waste liquid in the factory's drainage system. Users are requested to dispose of waste ink according to local laws and regulations.
	Cleaning station Connector: User: Horse Φ27 to 28 mm (I.D) + Band Machine: Fitting Φ29 mm (O.D)	
Exhaust	Flow rate: 1,200 m ³ /hr {73,228,493 in ³ /h} Connector: User: Horse Φ125 mm (I.D) + Band Machine: Pipe Φ123 mm (O.D)	Required for mist exhaust in the machine. If a 1,200 m ³ /h exhaust system is not available, please provide a mist exhaust fan.
Network	A communication speed of 100BASE-TX or more is recommended. Use a shielded twisted-pair cable (Category 5 or higher).	Please provide a network environment to which a PC can be connected.

ML-32000-240

Item	Specifications	Notes
Voltage	400 V \pm 10 %, 3-phase + Neutral + Earth	
Frequency	50 / 60 Hz \pm 3 %	
Rated apparent power	31.1 kVA	
Power consumption	Printing Approx. 7.0 kW	
Power consumption (with hot roller option)	Printing Approx. 12 kW	
Rated current	45 A	
Leakage current	300 mA or less	
Factory facilities Connected/Wired	Type: Terminal block connection Connecting part model: Power: CB510 (Manufacturer. by Cabur) Ground: TO210 (Manufacturer. by Cabur) Compatible crimped terminals (reference): Ferrule type WP160/22 Wiring specifications (recommended): 600 V withstand voltage (UL1063 equivalent) Wire size of 10 mm ² (AWG6) or larger	

Factory facilities

Item	Specifications	Notes
Electrical power	Refer to "ML-32000-240" on page 19.	
Compressed air	Pressure: Min. 0.6 MPa (6 bar) Required air flow capacity: 250 L/min Connector: User: Tube Φ 12 mm (O.D) Machine: Fitting Φ 12 mm (O.D)	Required for raising/lowering the cleaning tank, ink pressure, etc. Air consumption is the amount of air in an hour. This is used to select compressors. The required air flow capacity is the flow rate which needs to be supplied from factory to the machine within a short period of time. This is used to select the main piping to the machine.
Water	Pressure: 0.4 Mpa (4 bar) - 0.6 MPa (6 bar) Flow rate: Max. 100 Liter/hr {6,102 in ³ /h} Connector: User: Horse + Fitting (R3/4) Machine: Fitting (Rc3/4)	Required for belt cleaning.
Wastewater	Flow rate: Max. 100 Liter/hr {6,102 in ³ /h} Connector: User: Horse + Fitting Machine: PVC pipe nominal diameter 40A (Φ 48 mm (O.D))	Required for wastewater for belt cleaning. Users are requested to dispose of wastewater according to local laws and regulations.
Waste liquid	Flushing plate Connector: User: Horse Φ 12 mm (I.D) + Band Machine: Fitting Φ 14 mm (O.D)	Waste ink is discharged from the flushing plate and cleaning station, and therefore it is necessary to provide a route for waste liquid in the factory's drainage system. Users are requested to dispose of waste ink according to local laws and regulations.
	Cleaning station Connector: User: Horse Φ 27 to 28 mm (I.D) + Band Machine: Fitting Φ 29 mm (O.D)	
Exhaust	Flow rate: 1,600 m ³ /hr {98,000,000 in ³ /h} Connector: User: Horse Φ 125 mm (I.D) + Band Machine: Pipe Φ 123 mm (O.D)	Required for mist exhaust in the machine. If a 1,600 m ³ /h exhaust system is not available, please provide a mist exhaust fan.
Network	A communication speed of 100BASE-TX or more is recommended. Use a shielded twisted-pair cable (Category 5 or higher).	Please provide a network environment to which a PC can be connected.

ML-16000-340

Item	Specifications	Notes
Voltage	400 V \pm 10 %, 3-phase + Neutral + Earth	
Frequency	50 / 60 Hz \pm 3 %	
Rated apparent power	34.6 kVA	
Power consumption	Printing Approx. 8.0 kW	
Power consumption (with hot roller option)	Printing Approx. 15 kW	
Rated current	50 A	
Leakage current	300 mA or less	
Factory facilities Connected/Wired	<p>Type: Terminal block connection</p> <p>Connecting part model: Power: CB510 (Manufacturer. by Cabur) Ground: TO210 (Manufacturer. by Cabur)</p> <p>Compatible crimped terminals (reference): Ferrule type WP160/22</p> <p>Wiring specifications (recommended): 600 V withstand voltage (UL1063 equivalent) Wire size of 16 mm² (AWG6) or larger.</p>	

Factory facilities

Item	Specifications	Notes
Electrical power	Refer to " ML-16000-340 " on page 21.	
Compressed air	Pressure: Min. 0.6 MPa (6 bar) Required air flow capacity: 180 L/min Air consumption: 3,300 L/h Connector: User: Tube Φ 12 mm (O.D) Machine: Fitting Φ 12 mm (O.D)	Required for raising/lowering the cleaning tank, ink pressure, etc. Air consumption is the amount of air in an hour. This is used to select compressors. The required air flow capacity is the flow rate which needs to be supplied from factory to the machine within a short period of time. This is used to select the main piping to the machine.
Water	Pressure: 0.4 Mpa (4 bar) - 0.6 MPa (6 bar) Flow rate: Max. 100 Liter/hr {6,102 in ³ /h} Connector: User: Horse + Fitting (R3/4) Machine: Fitting (Rc3/4)	Required for belt cleaning.
Wastewater	Flow rate: Max. 100 Liter/hr {6,102 in ³ /h} Connector: User: Horse + Fitting Machine: PVC pipe nominal diameter 40A (Φ 48 mm (O.D))	Required for wastewater for belt cleaning. Users are requested to dispose of wastewater according to local laws and regulations.
Waste liquid	Flushing plate Connector: User: Horse Φ 12 mm (I.D) + Band Machine: Fitting Φ 14 mm (O.D)	Waste ink is discharged from the flushing plate and cleaning station, and therefore it is necessary to provide a route for waste liquid in the factory's drainage system. Users are requested to dispose of waste ink according to local laws and regulations.
	Cleaning station Connector: User: Horse Φ 27 to 28 mm (I.D) + Band Machine: Fitting Φ 29 mm (O.D)	
Exhaust	Flow rate: 2,300 m ³ /hr {138,000,000 in ³ /h} Connector: User: Horse Φ 125 mm (I.D) + Band Machine: Pipe Φ 123 mm (O.D)	Required for mist exhaust in the machine. If a 2,300 m ³ /h exhaust system is not available, please provide a mist exhaust fan.
Network	A communication speed of 100BASE-TX or more is recommended. Use a shielded twisted-pair cable (Category 5 or higher).	Please provide a network environment to which a PC can be connected.

Supported Ink

The supported inks are subject to change without notice. Check with the distributor where the machine was purchased for the latest information.

Supported Ink (3L)

For 3L ink cartridge model.

Ink Type	Color Name	Color Code	Product No.
Acid	Black	BK	C13T661111 C13T66111A
	Cyan	C	C13T661211
	Magenta	M	C13T661310
	Yellow	Y	C13T661412
	Grey	GY	C13T661711 C13T66171A
	Red	R	C13T661811 C13T66181A
	Blue	BL	C13T661910
	Cobalt	CO	C13T661911 C13T66191A
	Orange	OR-F	C13T661A11 C13T661A1A
	Rubine	RB	C13T661C10 C13T661C1A
	Fluorescent Pink	FP	C13T661E10
	Fluorescent Flavine	FL	C13T661D10
	Vermilion	VE	C13T661H10

Ink Type	Color Name	Color Code	Product No.
Reactive	Black	BK	C13T662111 C13T66211A
	Cyan	C	C13T662210 C13T66221A
	Magenta	M	C13T662310 C13T66231A
	Yellow	Y	C13T662410 C13T66241A
	Grey	GY	C13T662710 C13T66271A
	Red	R	C13T662810 C13T66281A
	Blue	BL	C13T662910 C13T66291A
	Orange	OR	C13T662A10 C13T662A1A
	Crimson	CR	C13T662B10 C13T662B1A
	Grey (GOTS)*1	GY-G	C13T662C10 C13T662C1A
Disperse	Black	BK	C13T663111
	Cyan	C	C13T663210
	Magenta	M	C13T663310
	Yellow	Y	C13T663410
	Grey	GY	C13T663711
	Red	R	C13T663810
	Blue	BL	C13T663910
	Orange	OR	C13T663A10

Ink Type	Color Name	Color Code	Product No.
Pigment	Black	BK	C13T930111 C13T93011A
	Cyan	C	C13T930211 C13T93021A
	Magenta	M	C13T930311 C13T93031A
	Yellow	Y	C13T930411 C13T93041A
	Grey	GY	C13T930711 C13T93071A
	Red	R	C13T930811 C13T93081A
	Green	GR	C13T930911 C13T93091A
	Orange	OR	C13T930A11 C13T930A1A
Others	Ink Penetration Liquid (Acid ink, reactive ink) ^{*2}	AC	C13T661P10
	Ink Penetration Liquid (Disperse ink) ^{*2}	AC	C13T51MA10

^{*1} GOTS: Global Organic Textile Standard

^{*2} Do not use colors (rows) next to Across in the same head. The discharge of Across may become unstable. For more information, refer to "Colour" in the Leonardo Reference Guide or contact service support.

Supported Ink (10L)

For 10L ink cartridge model.

Ink Type	Color Name	Color Code	Product No.
Acid	Black	BK	C13T49Q110 C13T49Q11A
	Cyan	C	C13T49Q210
	Magenta	M	C13T49Q310
	Yellow	Y	C13T49Q410
	Grey	GY	C13T49Q510 C13T49Q51A
	Red	R	C13T49Q610 C13T49Q61A
	Blue	BL	C13T49Q710
	Cobalt	CO	C13T49Q810 C13T49Q81A
	Orange	OR-F	C13T49QA10 C13T49QA1A
	Rubine	RB	C13T49QB10 C13T49QB1A
	Fluorescent Pink	FP	C13T49QE10
	Fluorescent Flavine	FL	C13T49QF10
	Vermilion	VE	C13T49QH10

Ink Type	Color Name	Color Code	Product No.
Reactive	Black	BK	C13T49R110 C13T49R11A
	Cyan	C	C13T49R210 C13T49R21A
	Magenta	M	C13T49R310 C13T49R31A
	Yellow	Y	C13T49R410 C13T49R41A
	Grey	GY	C13T49R510 C13T49R51A
	Red	R	C13T49R610 C13T49R61A
	Blue	BL	C13T49R710 C13T49R71A
	Orange	OR	C13T49R810 C13T49R81A
	Crimson	CR	C13T49RB10 C13T49RB1A
	Grey (GOTS)*1	GY-G	C13T49RC10 C13T49RC1A
Disperse	Black	BK	C13T49S110
	Cyan	C	C13T49S210
	Magenta	M	C13T49S310
	Yellow	Y	C13T49S410
	Grey	GY	C13T49S510
	Red	R	C13T49S610
	Blue	BL	C13T49S710
	Orange	OR	C13T49S810

Ink Type	Color Name	Color Code	Product No.
Pigment	Black	BK	C13T49U110 C13T49U11A
	Cyan	C	C13T49U210 C13T49U21A
	Magenta	M	C13T49U310 C13T49U31A
	Yellow	Y	C13T49U410 C13T49U41A
	Grey	GY	C13T49U510 C13T49U51A
	Red	R	C13T49U610 C13T49U61A
	Green	GR	C13T49U710 C13T49U71A
	Orange	OR	C13T49U810 C13T49U81A
Others	Ink Penetration Liquid (Acid ink, reactive ink) ^{*2}	AC	C13T49QG10
	Ink Penetration Liquid (Disperse ink) ^{*2}	AC	C13T49SA10

^{*1} GOTS: Global Organic Textile Standard

^{*2} Do not use colors (rows) next to Across in the same head. The discharge of Across may become unstable. For more information, refer to "Colour" in the Leonardo Reference Guide or contact service support.

Ink Cartridges

Ink Cartridges (3L)

For 3L ink cartridge model.

Item	Specifications
Ink Type	Refer to "Supported Ink (3L)" on page 23.
External dimensions	Width (W): 180 mm {7.1 in} Length (D): 370 mm {14.6 in} Height (H): 70 mm {2.8 in}
Weight	Approx. 3.3 kg {7.3 lb}
Ink color	Refer to "Supported Ink (3L)" on page 23.
Transport and storage environment	(1) Temperature: 10 to 35°C {50 to 95 °F} (recommended warranty temperature) For long-term storage of reactive ink cartridges, avoid direct sunlight and keep the cartridges in an indoor environment (recommended: cool, dark place) at an ambient temperature of 30°C {86 °F} or lower. (2) Relative humidity: 35 to 85 % (no condensation)
Orientation during transport and storage	During transport and storage, ink cartridges should be kept with the largest surface facing up. Keep the upward arrow symbol on the box pointing upward.
Stack height during transport and storage	12 cartridges high

Ink Cartridges (10L)

For 10L ink cartridge model.

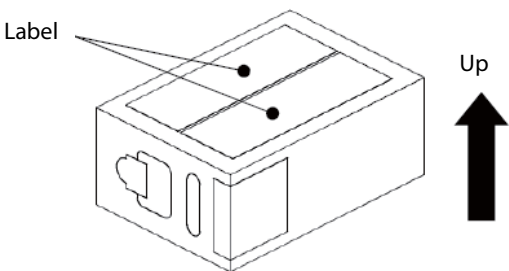
Item	Specifications
Ink Type	Refer to " Supported Ink (10L) " on page 26.
External dimensions	Width (W): 150 mm {5.9 in} Length (D): 235 mm {9.2 in} Height (H): 412 mm {16.2 in}
Weight	Approx. 11 kg {388 lb}
Ink color	Refer to " Supported Ink (10L) " on page 26.
Operating environment conditions with ink cartridges installed	(1) Temperature: 20 to 30 °C {68 to 86 °F} (2) Relative humidity: 35 to 85 % (no condensation) (3) The ink in a cartridge that has been left in a low temperature environment will freeze at a temperature of -10 °C {14 °F} or less. If ink is frozen, thaw it at room temperature and then use the ink after it is within the operating temperature range. Reference: In a 25 °C {77 °F} environment it takes approximately 34 hours for frozen ink to warm from -10 to 20 °C {14 to 68 °F}.
Warranty period with ink cartridges installed	(1) Temperature/warranty period without I/C installed: -20 to 60 °C {-4 to 140 °F}/ Max. 5 days -20 to 40 °C {-4 to 104 °F}/ Max. 1 month With I/C installed: -20 to 40 °C {-4 to 104 °F}/ Max. 1 month (2) Relative humidity: 35 to 85 % (no condensation)
Transport and storage environment	(1) Temperature: 10 to 35 °C {50 to 95 °F} (recommended warranty temperature) (2) Relative humidity: 35 to 85 % (no condensation)
Recommended lifetime	Indicated on ink cartridge labels
Orientation during transport and storage	During transport and storage, ink cartridges should be oriented as shown below with the largest surface facing up. 
Stack height during transport and storage	6 cartridges high

* The expiration date is indicated on the ink cartridge box.

Consumables

Item	Specifications	Use
Wiper	C13S210156	Wiper unit replacement part
Cap	C13S210157	Cap unit replacement part
Cooling fan filters	C13S210158	Cooling fan filter replacement part
Washing silicone scraper (Soft type)	C13S210159	Washing silicone scraper replacement part ML-32000-180, ML-16000-180
Washing scraper	C13S210132	Washing T-shaped scraper replacement part ML-32000-180, ML-16000-180
Insulating Tape	C13S400213	For application of glue
Mist filter	C13S210133	Mist filter replacement part
Blower filter	C13S210134	Blower filter replacement part
2 inch Feeding Spindle	C12C939721	Feeding spindle for 2-inch (inner) paper tube
3 inch Feeding Spindle	C12C939731	Feeding spindle for 3-inch (inner) paper tube
Pressure roller	C12C939741	Pressure roller (metal type)
Glue blocks	C12C938661	For application of glue
Glue collection bucket	C12C938681	For removal of glue
Cleaning stick	C13S090011	For cleaning the cap, wiper, etc., soak this in cleaning liquid and use it.
Cleaning cloth	C13S210050	For wiping off ink and grease
Maintenance Liquid	C13T42X000	For cleaning the cap, suction cap, carriage surfaces other than the nozzle surface, and the head cover
Cleaning Liquid (3 L)	C13T661N10	For cleaning ink before initial charging
Cleaning Liquid(10 L)	C13T49Q010 C13T49Q000	

Name and Function of Each Part

This section describes the name and function of each part.

Name of Each Part

This section describes the name and function of each part.

Front

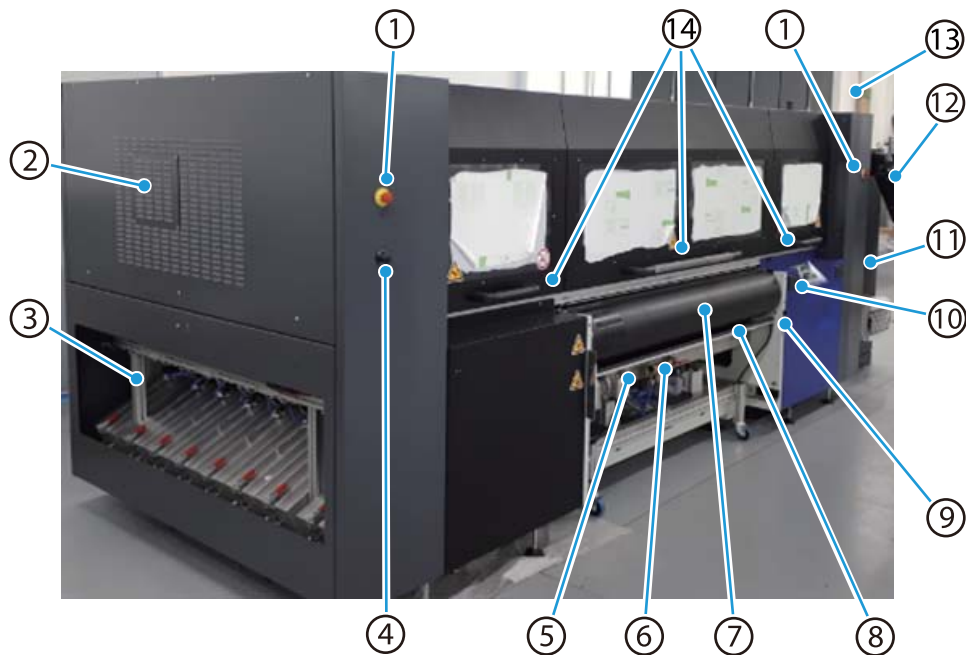

No.	Name	Description
1	Emergency stop button	Stops operation of this machine immediately.
2	Mist filter cover	Used to clean/replace the mist filter.
3	Ink rack	This rack contains the Ink cartridges (3L) or the Ink cartridge (10L).
4	Pause button	Printing is paused and the print head comes to a stop at either the flushing plate or the cleaning station.
5	Belt cleaning unit	Cleans ink and other foreign material adhering to the belt. Open this cover to clean the cleaning brushes and scrapers.
6	Water supply valve	This is the water supply valve on the belt cleaning unit.
7	Belt	This belt feeds fabric attached to it.
8	Entanglement detection sensor	Located on the lower front side of the belt. Prevents hands and fingers from becoming caught in the belt. It is installed on the belt cleaning unit.

No.	Name	Description
9	Tangled fabric detection sensor	Located on the front of the belt. Prevents fabric from becoming caught in the belt.
10	Front panel	Location of the operating panel for performing operations on the front of the machine.
11	Main electric box	Supplies power and houses the control PC.
12	Control PC	Used to control Leonardo from the main unit.
13	Tower lamps	<p>These lamps indicate the status of the machine.</p> <ul style="list-style-type: none"> • Red On: Fault status (Emergency stop or device error) • White Flashing: Machine currently operating • Green On: Printing standby status Flashing: Printing paused status • Blue On: Operator action required
14	Front covers	These are movable covers. Open these covers to clean and perform maintenance on the belt, caps & wipers, scan spindle, and flushing plate.

Front (When opening the front covers)

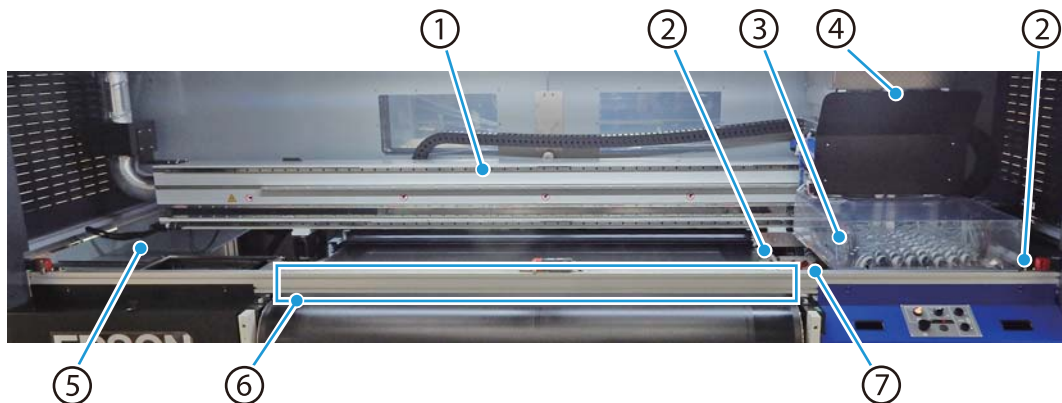

No.	Name	Description
1	Scan spindle	Spindle along which the print head moves from side to side.
2	Head stroke sensor	Detects foreign material on the belt as well as folds and wrinkles in the fabric.
3	Print head	Equipped with the print head used for printing on fabric.
4	Cooling fan	Lowers the temperature of the print head control substrate.
5	Flushing plate	The print head flushes the ink here.
6	Fabric peeling prevention bar	This bar prevents the peeled part of the fabric from floating up when winding the printed fabric in the dryer. Adjust the height of the bar whenever changing the fabric type or thickness. For more information, refer to "Adjusting the Fabric Peeling Prevention Bar" on page 55.
7	Cleaning station	Caps and wipers are located at the top, for performing cleaning and replacement.

Rear

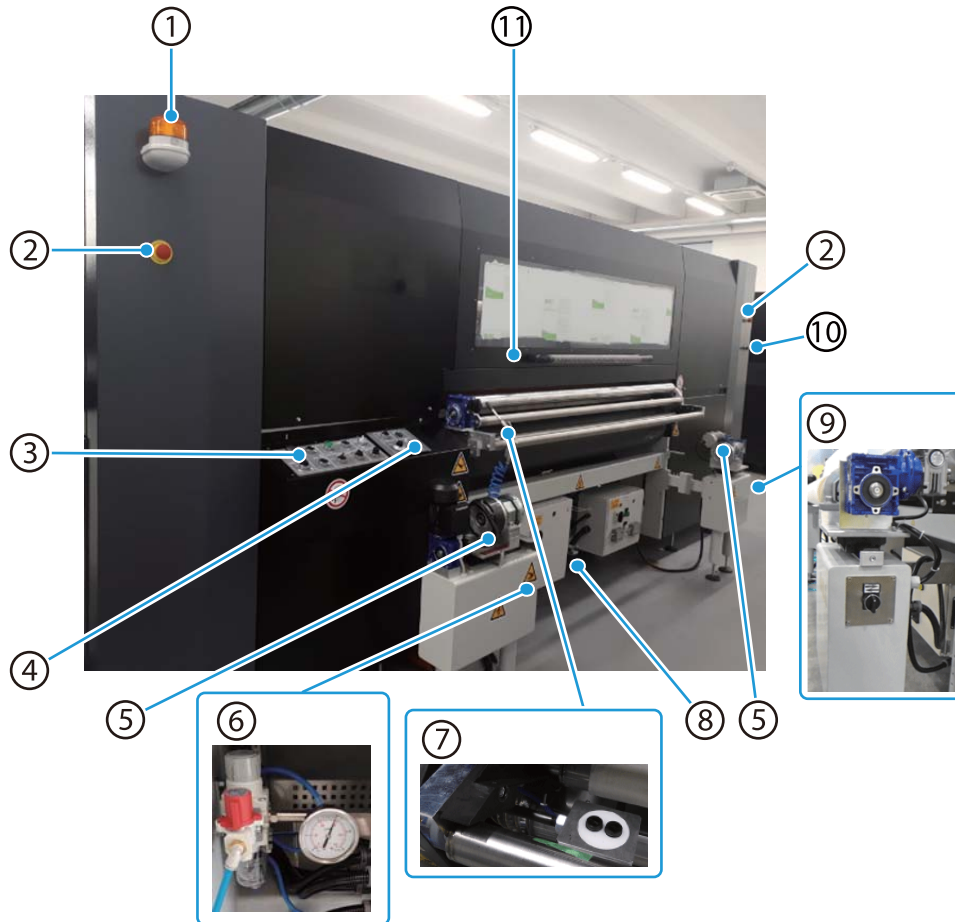

No.	Name	Description
1	Rotary beacon	Lights up and the buzzer sounds if the rear cover is opened while the machine is printing.
2	Emergency stop button	Stops operation of this machine immediately.
3	Rear panel	Location of the operating panel for performing operations on the rear of the machine.
4	Fabric tension adjustment panel	Use this panel to adjust the winding tension of the fabric.
5	Feeding unit	The fabric roll is installed here, and the unit feeds the fabric into the machine.
6	Air supply regulator	This regulator supplies compressed air.
7	Fabric edge sensor unit	This sensor detects the left edge position of the fabric.
8	Slack sensor	This sensor detects slack in the fabric.
9	Slack adjustment switch	In slack mode, the machine feeds out fabric to create slack.
10	Pause button	Printing is paused and the print head comes to a stop at either the flushing plate or the cleaning station.
11	Rear cover	These are movable covers. Open these covers to perform maintenance.

Rear (When opening the rear cover)

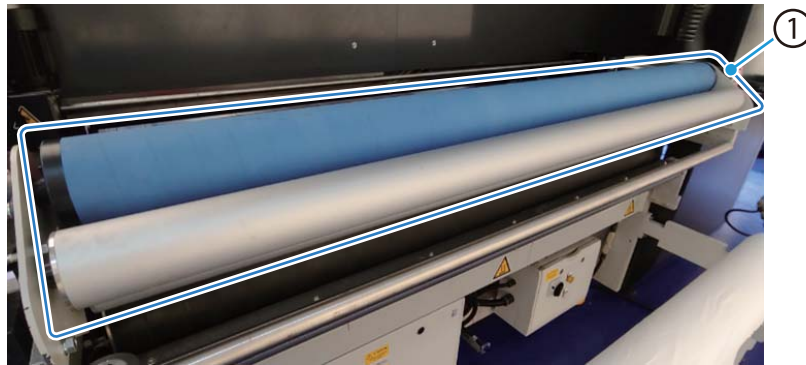

No.	Name	Description
1	emergency pull-wire switch	This is the axis that the print head moves from side to side. If you pull the rope, the operation of this machine will stop immediately. Pull the blue lever to release the emergency stop state. It has the same function as the emergency stop button.
2	Pressure roller	This roller swings above the fabric that is fed from the fabric guide bar, to affix the fabric to the belt.
3	Fabric guide bar	Fabric that is sent from the dewrinkling roller is lowered to the height of the belt and guided to the pressure roller.
4	Dewrinkling roller	Spreads the fabric side to side to remove wrinkles.

Tension Roller (Option)

No.	Name	Description
1	Tension roller	This applies a uniform tension to the fabric for feeding. It is installed in place of the dewrinkling roller.

Ink Rack (3L)

For 3L ink cartridge model.

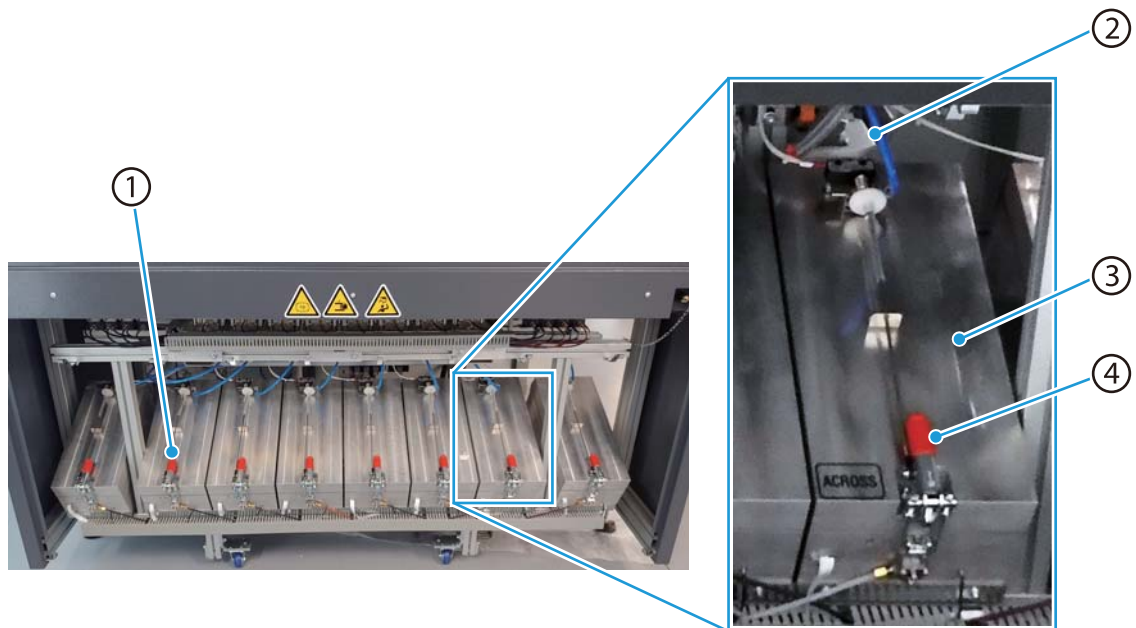

No.	Name	Description
1	Ink tank	Contains a 3L ink cartridge.
2	Cover support hook	Used to hook the tank opening/closing handle when the ink tank cover is open.
3	Ink tank cover	Ink tank cover. Open/close this cover when replacing the ink cartridge.
4	Tank opening/closing handle	Pull this handle to unlock the ink tank cover so that the ink tank cover can be lifted.

Inside of Ink Tank

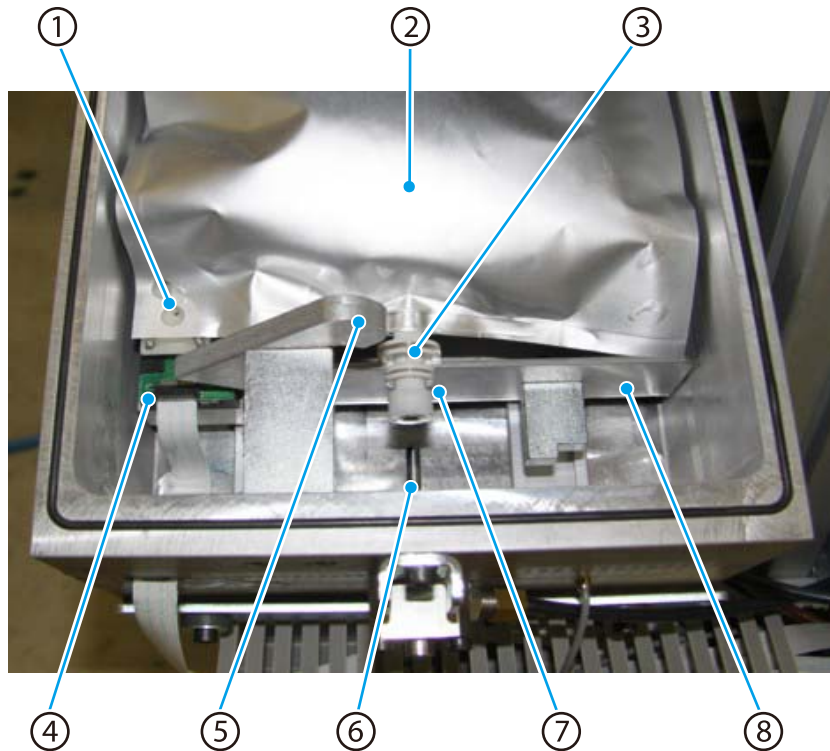

No.	Name	Description
1	IC chip	Connected to the reader to send information of the ink cartridge.
2	Ink cartridges	Ink cartridge that contains ink.
3	Ink cartridge supply port	Supplies ink from the ink cartridge to the machine.
4	Reader	Connected to the IC chip on the ink cartridge.
5	Lever	Used to lock the cartridge carriage.
6	Needle	Connected to the ink cartridge supply port.
7	Supply port securing section	Secures the ink cartridge supply port in position with the cutout on the cartridge carriage.
8	Cartridge carriage	The ink cartridge is placed on this carriage.

Ink Rack (10L)

For 10L ink cartridge model.



No.	Name	Description
1	Ink rack	Supplies ink from the ink cartridges. The amount of ink remaining is shown on Leonardo. If a cartridge needs to be replaced, a message is displayed on Leonardo.
2	Ink cartridges	These are 10 L ink cartridges. They are mounted in the ink rack. From the left side, they are positioned in order A through H.
3	Ink rack front bar	Bar to prevent ink cartridges from falling out.

Sub Tank Pressure Regulator and Cartridge Check Lamp

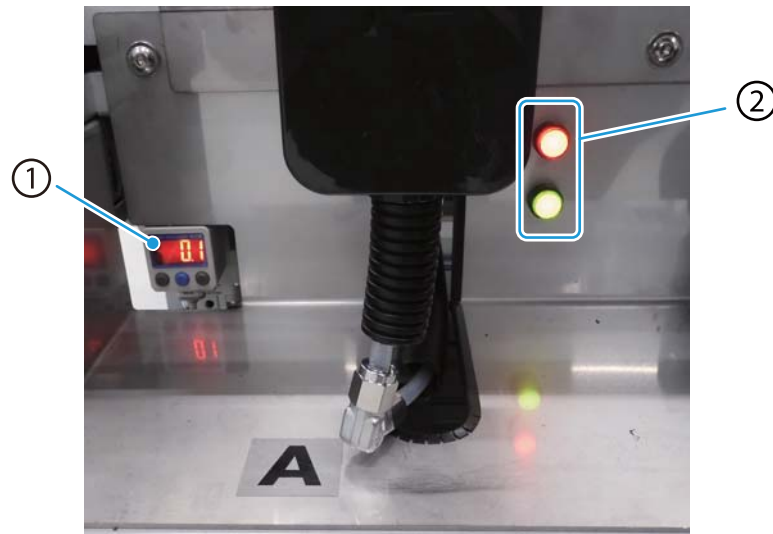

No.	Name	Description
1	Pressure regulator for subtanks	Displays the air pressure supplied to the sub tank of each ink path. Specified value is 34 ± 1 kPa.
2	Cartridge check lamp	<p>Indicates the status of the ink cartridges and ink.</p> <ul style="list-style-type: none"> • Red <ul style="list-style-type: none"> On: <ul style="list-style-type: none"> • There is no ink remaining in the cartridge. Replace the ink cartridge. • The ink cartridge is not connected. Connect the ink cartridge. • The ink type or color is not correct. Connect the correct ink cartridge. Flashing: The ink rack front bar is open. • Green <ul style="list-style-type: none"> On: Ink is being supplied to the ink path. Flashing: The ink rack front bar is open.

Control Panel

Main electric panel

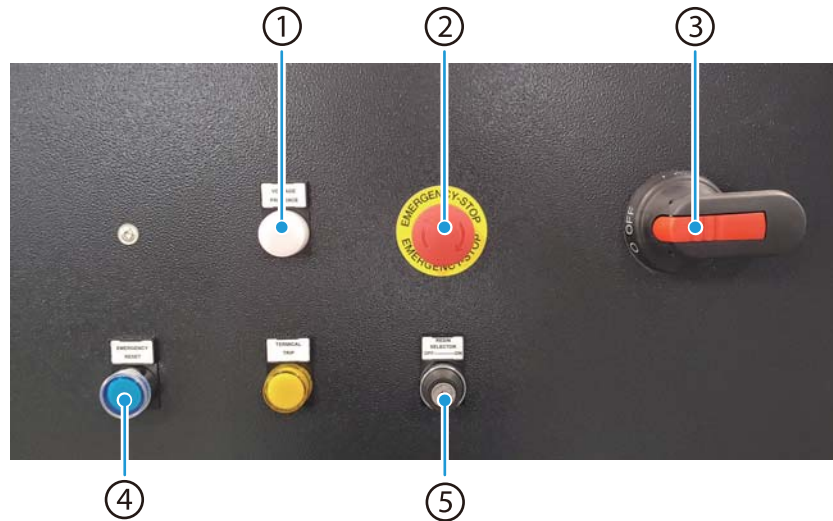

No.	Name	Description
1	Power lamp	The printer's operational status is indicated. On: The power is on. Off: The power is off.
2	Emergency stop button	Stops operation of this machine immediately.
3	Main power switch	Turns the power on and off. 0: Power off. 1: Power on.
4	Reset button	Press this button after selecting Setpoint to start the Setpoint operation.
5	Maintenance key switch	Insert the maintenance key when reapplying the glue. For more information, refer to "Glue Re-Application" in the Maintenance Guide.



CAUTION

If the power is turned on while the maintenance key is still inserted, the belt operation safety function during printing (device operation) will be disabled, resulting in a dangerous situation. Therefore, do not insert the maintenance key except for when applying glue for maintenance work.

The maintenance key must be kept by the person authorized by the employer and must never be left inserted in the electrical panel.

The maintenance key used for the maintenance for glue re-application must be in a safe and locked place and under the full responsibility of the person in charge of.

Front panel

Buttons and switches equipped vary depending on the model. (Pattern A or B) Check your printer and understand how to use it.

Pattern A

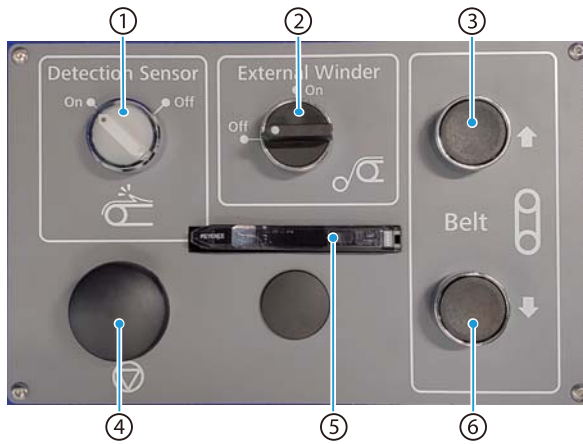

Pattern B

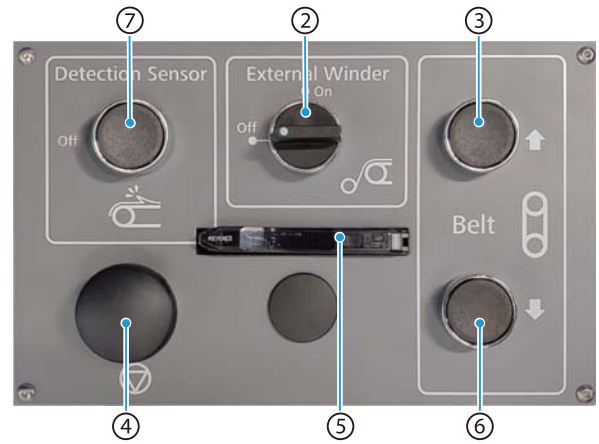

No.	Name	Description
1	Foreign material detection sensor switch	Use this switch to change the operation the foreign material detection sensor. Off: Disable On: Enable The manufacturer recommends not switching off this function except to overcome the obstacle. Epson do not assume any responsibility in case of misuse of the foreign material detection sensor.
2	External winder switch	Use this switch to change the signal from an external winder. Off: Disable On: Enable
3	Back feed button	Press and hold this button to feed the belt in the reverse direction (from front to rear).
4	Pause button	Printing is paused and the print head comes to a stop at either the flushing plate or the cleaning station. Press the Leonardo [Start] icon to resume printing.
5	Foreign material detection sensor controller	Use this to set and display the detection threshold value of the foreign material detection sensor. For threshold values, refer to " Setting the Foreign Material Detection Sensor " on page 94.
6	Feed button	Press and hold this button to feed the belt in the forward direction (from rear to front).
7	Foreign material detection sensor off button	The foreign material detection sensor is turned off (disabled) while this button is pressed. Note that Epson shall bear no responsibility for any outcome that occurs as a result of how the foreign material detection sensor is set. Do not push this button, except when removing an impediment.

Rear panel

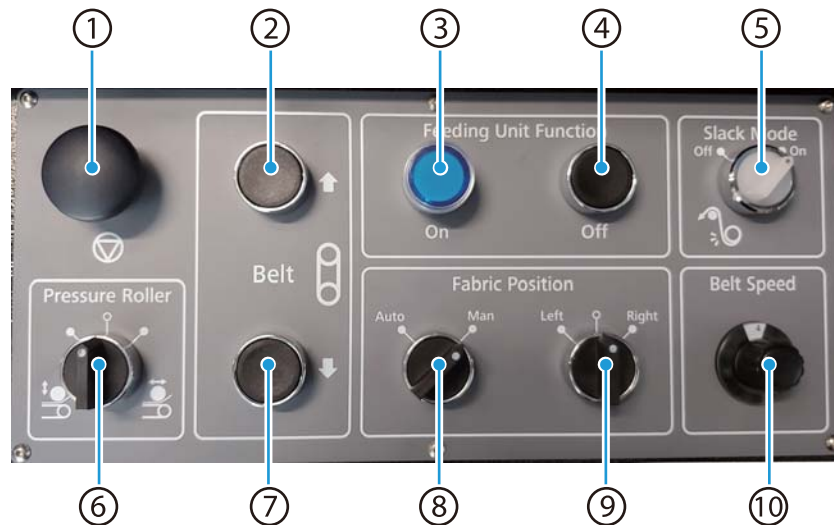

No.	Name	Description
1	Pause button	Printing is paused and the print head comes to a stop at either the flushing plate or the cleaning station. Press the [Start] icon on Leonardo to resume printing.
2	Feed button	Press and hold this button to feed the belt in the forward direction (from rear to front).
3	Feeding unit button (On)	Press this button to turn On (enable) the feeding unit. (Turn on when adjusting the fabric position and when the slack mode is enabled.)
4	Feeding unit button (Off)	Press this button to turn Off (disable) the feeding unit.
5	Slack detection switch	Use this switch to change the operation of the slack sensor. Off: Disable On: Enable
6	Pressure roller switch	Use this switch to change the operation of the pressure roller. If you spin it to the left then let go, the switch automatically returns to the standby position (center). If you spin it to the right, the switch stays in that position and continues operation. To stop operation, manually return the switch to the standby position (center). Left : Moves the pressure roller up/down. Each time the switch is turned to the left, the pressure roller moves up/down. Right : Moves the pressure roller forward/backward. Turn to the right to operate, or to the center to stop the pressure roller.
7	Back feed button	Press and hold this button to feed the belt in the reverse direction (from front to rear).

No.	Name	Description
8	Fabric position adjustment switch (Auto)	Set the operation of fabric position adjustment. Auto: Fabric position adjusted automatically. Man: Fabric position adjusted manually.
9	Fabric position adjustment switch (LR)	Move the fabric position left and right. This switch is enabled only when the fabric position adjustment switch (Auto) is set to Man. Left: Moves to the left. Right: Moves to the right.
10	Belt speed volume	Adjust the speed of the belt when applying the glue. For more information, refer to "Glue Re-Application" in the Maintenance Guide.

Fabric tension adjustment panel



No.	Name	Description
1	Feeding unit tension switch	Use this switch to enable/disable the tension. Off: Disable On: Enable
2	Tension adjustment dial	Adjusts the tension applied to the fabric. Raise the tension if wrinkles still occur in the fabric. Turn to right: Raises the tension. Turn to left: Lowers the tension.
3	Tention roller switch	Use this switch to enable/disable the tension of the tension roller. Off: Disabled On: Enabled
4	Tension adjustment dial	Adjusts the tension applied to the fabric. Raise the tension if wrinkles still occur in the fabric.

Workflow before Beginning Work

This section describes the items to be checked before beginning work.

Workflow

Operations and Check Items for Rear Side

1. Supplying and Adjusting Compressed Air ([Page 48](#))
2. Removing the Stopper Pin of the Pressure Roller ([Page 50](#))
3. Lowering the Towel Roller ([Page 51](#))

Workflow for Front Side

1. Supplying Water to the Belt Cleaning Unit ([Page 53](#))

Other

1. Prepare the Fabric ([Page 54](#))
2. Adjusting the Fabric Peeling Prevention Bar ([Page 55](#))
3. Checking Operating Parts ([Page 58](#))
4. Checking the Exhaust Equipment ([Page 59](#))

Procedure for Turning on the Power

1. Pushing an Emergency Stop Button for an Emergency Stop ([Page 60](#))
2. Turning On the Power ([Page 60](#))
3. Starting Leonardo ([Page 61](#))
4. Releasing an Emergency Stop Button ([Page 62](#))
5. Executing Setpoint ([Page 63](#))

Operations and Check Items After Turning on the Power

1. Checking the Operation of the Emergency Stop Equipment ([Page 64](#))
2. Inspecting for Leaks in the Ink Path ([Page 65](#))
3. Inspecting the Open Cover Detection ([Page 66](#))
4. Nozzle Check ([Page 67](#))
5. Head Cleaning ([Page 70](#))

Supplying and Adjusting Compressed Air

Supplies compressed air in order to operate the machine. The machine will not operate if the specified air pressure is not supplied. An air pressure that is higher than the specified air pressure could cause the machine to malfunction. Please check the air pressure before operating the machine.

Supply of Compressed Air

Turn the red valve on the air supply regulator counterclockwise to change the indicator for the valve from “EXH” to “SUP”.

Confirm that the meter moves and that air is supplied.

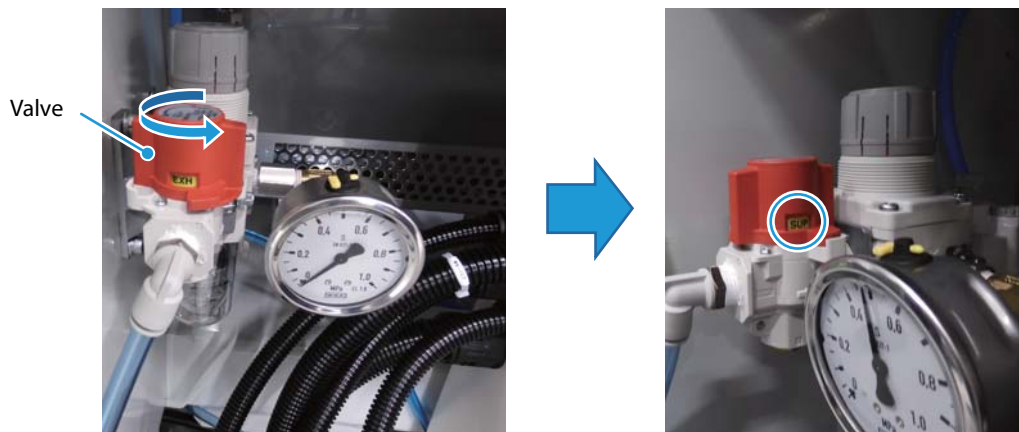

Checking and Adjusting Air Pressure

Confirm that the pressure indicated by the meter on the air supply regulator is within the range stipulated in the specifications. For air pressure specifications, refer to ["Power" on page 17](#). Use the pressure adjustment handle to adjust the air pressure as necessary.

- 1** Make sure that the valve is set to “SUP” (air pressure is applied).
- 2** Check the pressure indicated by the meter, and use the pressure adjustment handle to adjust the air pressure as necessary.

Clockwise: Raises the pressure.

Counterclockwise: Lowers the pressure.

If the pressure does not rise to the specified value, adjust the pressure in the factory.

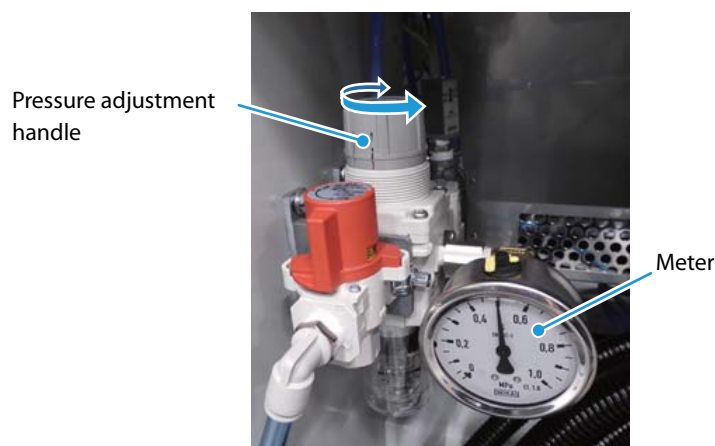

Removing Impurities from the Air Filter

The air filter removes impurities and water in the compressed air. Follow the procedures below to remove any impurities and water that have accumulated in the filter.

- 1** Turn the red valve on the air supply regulator clockwise to change the indicator for the valve from "SUP" to "EXH".
Make sure that the meter indicates 0 (zero).
- 2** Set the plastic container under the drain and press the two orange buttons.
Check to see that the accumulated water was discharged.



- 3** Turn the red valve on the air supply regulator counterclockwise to change the indicator for the valve from "EXH" to "SUP".
Confirm that the meter moves and that air is supplied.

If impurities and water are not discharged

- 1** Turn the red valve on the air supply regulator counterclockwise to change the indicator for the valve from "EXH" to "SUP".
- 2** Set the plastic container under the air filter drain.
- 3** Press the two orange buttons. The water and impurities that have accumulated in the air filter will be discharged with force.

Removing the Stopper Pin of the Pressure Roller

- 1 Open the rear cover.
- 2 Remove the stopper pin located at the lower part on the right side of the pressure roller.

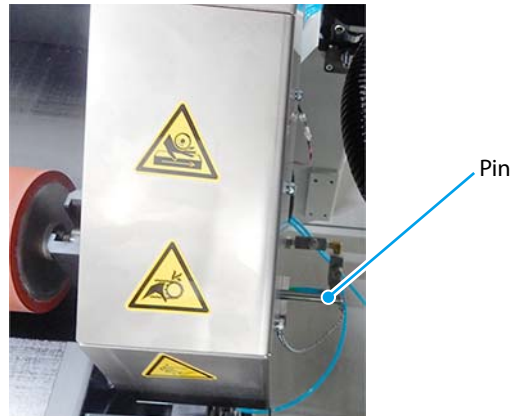

- 3 Remove the stopper pin on the left side of the pressure roller.

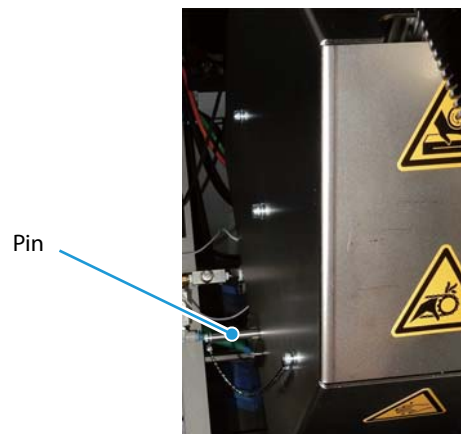



- 4 Close the rear cover.

Lowering the Towel Roller

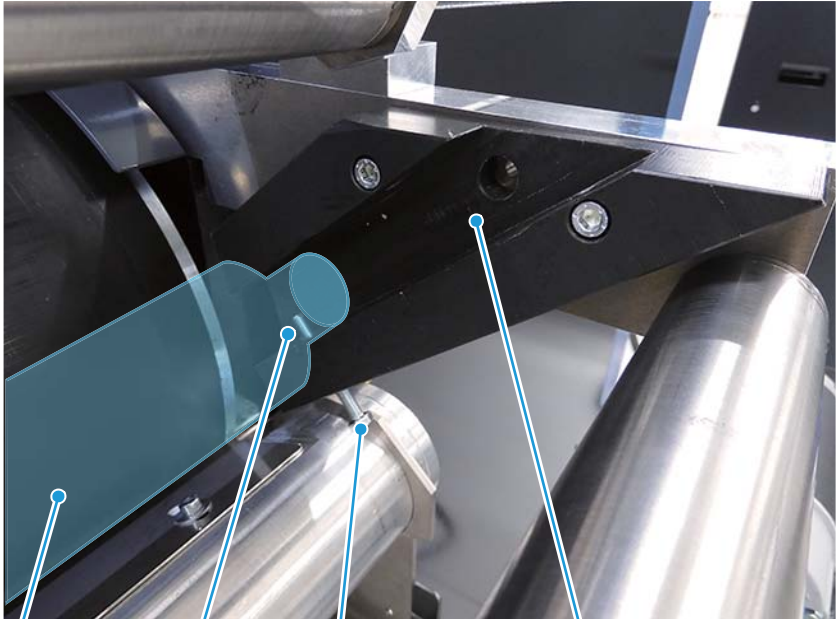
Lower the towel roller until it touches the belt.

	<p>The supporting screw sticking out into the towel roller groove supports the towel roller spindle and prevents it from lowering.</p> <p>While the towel roller is in the upper position, it is placed on the supporting screw sticking out into the groove to prevent the spindle from lowering.</p> <p>Towel roller in upper position</p>  <p>Towel roller Supporting screw Towel roller groove</p> <p>Supporting screw sticking out into the groove supports the towel roller spindle</p> <p>To lower the towel roller, loosen the supporting screw so that the towel roller spindle can pass through the groove.</p>
---	--

- 1 While lifting up the right side of the towel roller toward you, loosen the supporting screw (right) by hand.

 CAUTION	When the supporting screw is loosened, the towel roller automatically lowers under its own weight. Be careful not to get your fingers caught between the towel roller and the belt.
	There is no need to remove the supporting screw. You can lower the towel roller only by loosening the screw.

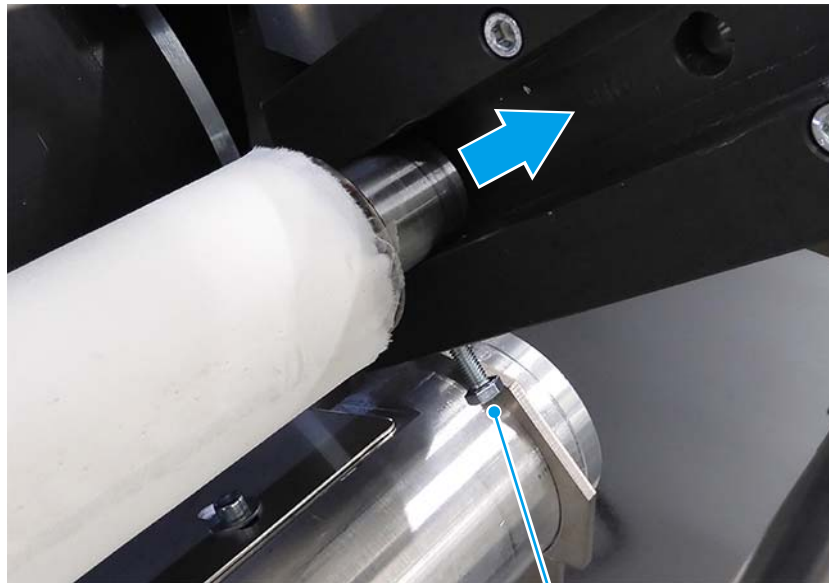

Supporting screw

- 2 Lower the towel roller gradually along the groove until it touches the belt.



- 3 Repeat procedures 1 and 2 on the left side of the towel roller.

Supplying Water to the Belt Cleaning Unit

The belt cleaning unit washes ink from the belt and dries the belt.

Opening the Water Supply Valve

Open the water supply valve at the bottom of the front of the machine. Adjust the open/close amount to match the use conditions.

Using a flat-head screwdriver, open the water supply valve.

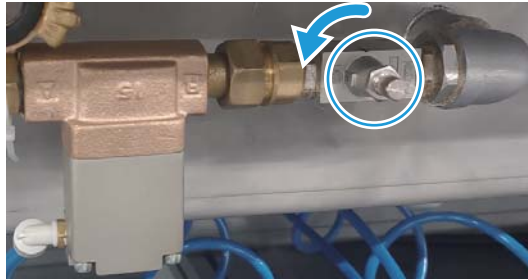



The belt cleaning unit will not operate until printing starts.
For operation check, refer to "[Checking the Belt Cleaning Unit Operation](#)" on page 120.
For the pressure of the water supply, refer to "[Power](#)" on page 17.

Prepare the Fabric

Before setting the fabric, be sure to confirm the following status.

- **Fabric edge:** Confirm that there are no folds or protrusions and that the fabric is not lifted up or frayed. If the fabric is frayed, perform overcasting.
- **Seams:** Confirm that there are no protrusions and that the fabric is not frayed.

 WARNING	<p>If the fabric touches the print head, the print head may be damaged. The fabric must be fed and adhere to the belt without any folds, protrusions, seams, or lifting in the fabric edge whatsoever.</p>
 CAUTION	<p>An incorrect fabric thickness and print head height setting can cause collisions with the fabric, resulting in print head failure. Set the fabric thickness and the foreign material detection sensor when loading the fabric for the first time or changing the fabric type or thickness. If the fabric is thicker than 2 mm, the threshold value must also be adjusted. Fabric Thickness (Page 97) Foreign material detection sensor (Page 94)</p>

If fiber containing moisture from the ink lifts up, it may come into contact with the head passing over the fabric. To avoid this, make the fabric edge firmly adhere to the belt.

Adjusting the Fabric Peeling Prevention Bar

The fabric peeling prevention bar is installed 5 mm above the belt. Depending on the thickness of the fabric, the fabric might not be able to pass below the fabric peeling prevention bar, causing a collision with print head and malfunctions. Adjust the height of the fabric peeling prevention bar whenever changing the fabric type or thickness.

- 1** Open the front cover.
- 2** Use a hex key (width: 4 mm) to loosen the screws on the fabric peeling prevention bar (ML-32000-240/ ML-32000-180/ ML-16000-180: 4 screws, ML-16000-340: 8 screws) about half one rotation.

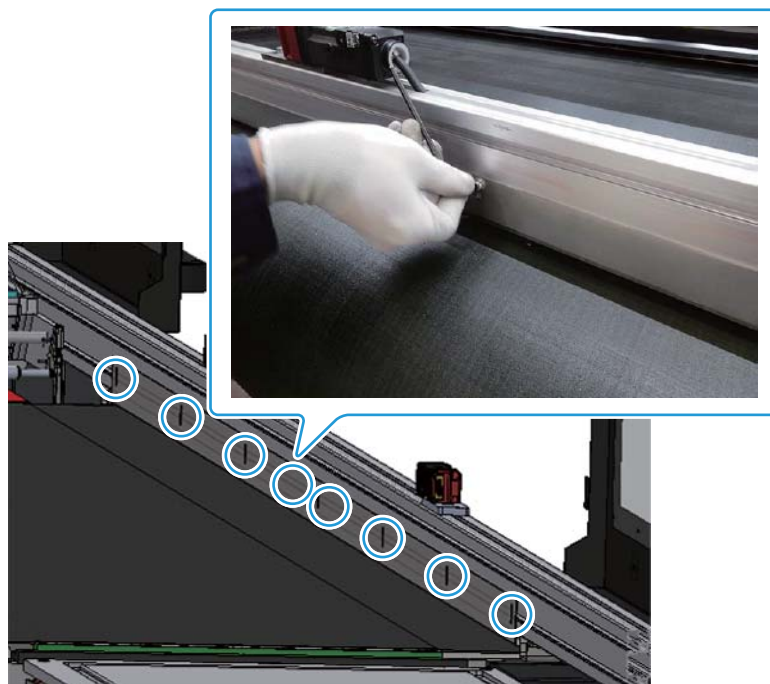

3 Lift the bar up from the belt to about 3 to 5 mm above the fabric thickness.

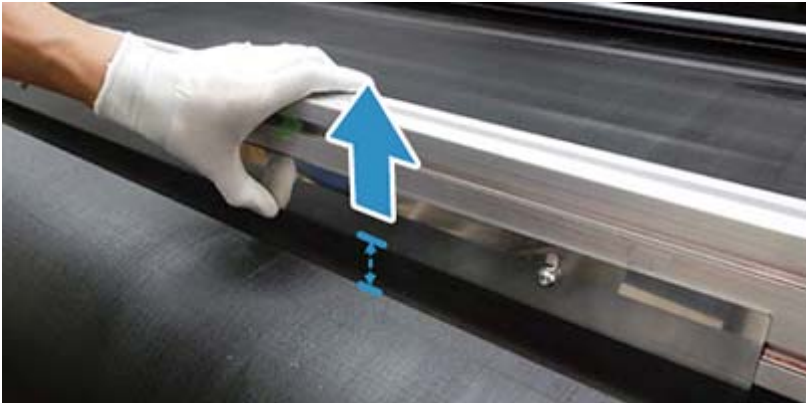

If using a ruler for measuring, be careful not to let the ruler get caught on the belt. Doing so could scratch or damage the belt.



4 Holding the bar in one hand, use a hex key (width: 4 mm) to tighten the rightmost and leftmost screws on the fabric peeling prevention bar.



- 5** Use a hex key (width: 4 mm) to tighten the remaining screws on the fabric peeling prevention bar.

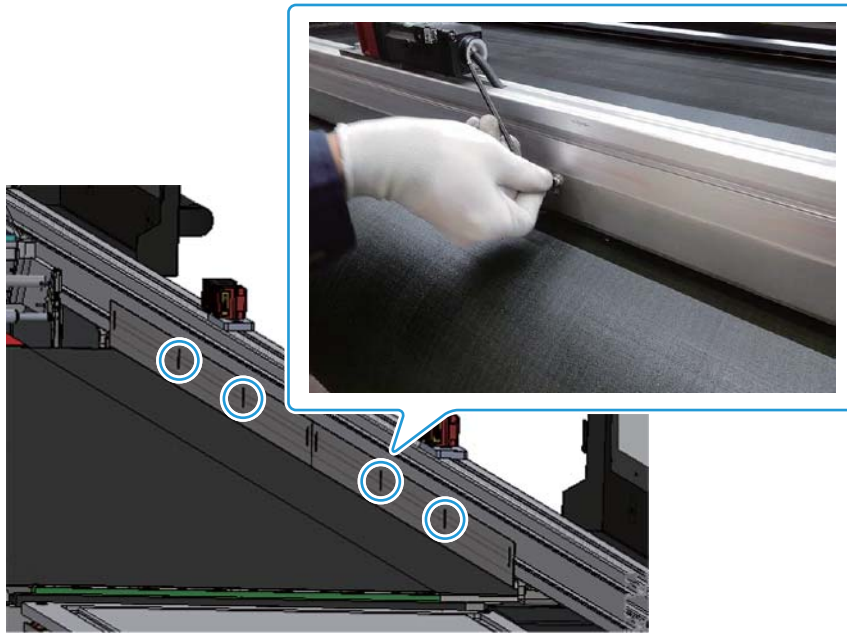

- 6** Close the front cover.

Checking Operating Parts

Do not place tools, fasteners, or the like on the belt or near the pressure roller or print head. Doing so could cause them to be entangled in the belt, pressure roller, or print head, damaging this machine. Before turning the power on, check that there is nothing left near the moving parts, such as on the belt or near the print head.

Front

- 1 Open the front cover of this machine.
- 2 Check that there are no tools, fasteners, or the like left on the belt or near the carriage or print head.



- 3 Close the front cover.

Rear

- 1 Open the rear cover of this machine.
- 2 Check that there are no tools, fasteners, or the like left near the belt or the pressure roller.

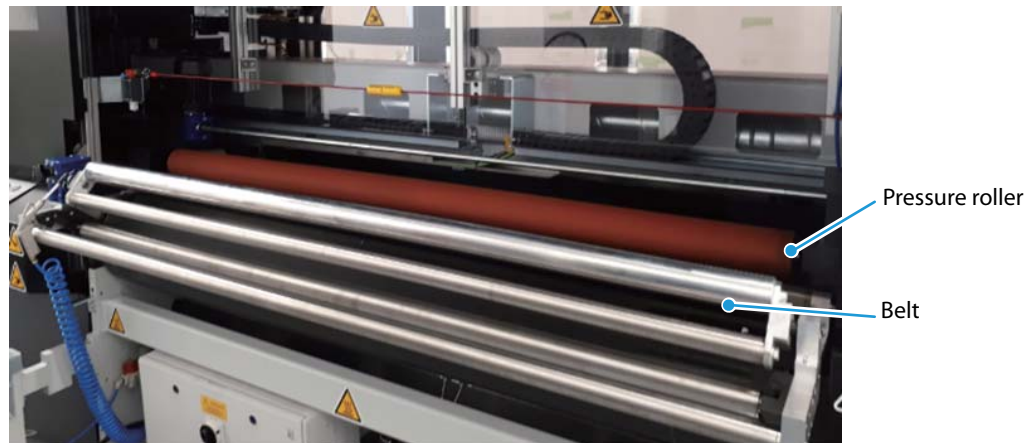

- 3 Close the rear cover of this machine.

Checking the Exhaust Equipment

Check if the exhaust is flowing while the machine is running, in order to adjust the temperature and humidity of the machine.

The location and method of checking exhaust ducts will vary depending on the equipment that is used. For more information, please check with the factory manager.



Pushing an Emergency Stop Button for an Emergency Stop

Push the emergency stop button to put the machine in emergency stop status, so that the print heads and motor do not operate suddenly when the power is turned on.

Emergency stop buttons are found in five locations around the machine. Firmly press one of these emergency stop buttons.



Turning On the Power

 CAUTION	<p>Confirm that the maintenance key is not inserted in maintenance key switch.</p> <p>If the power is turned on while the maintenance key switch is still inserted, the belt operation safety function during printing (device operation) will be disabled, resulting in a dangerous situation. Therefore, do not insert the maintenance key switch except for when applying glue for maintenance work.</p> <p>The maintenance key switch used for the maintenance for glue re-application must be in a safe and locked place and under the full responsibility of the person in charge of.</p>
	<p>Make sure that front covers and rear cover are closed before turning on the power.</p>

Turn the main power switch on the main electric panel to 1 (ON).

Confirm that the power lamp lights up.

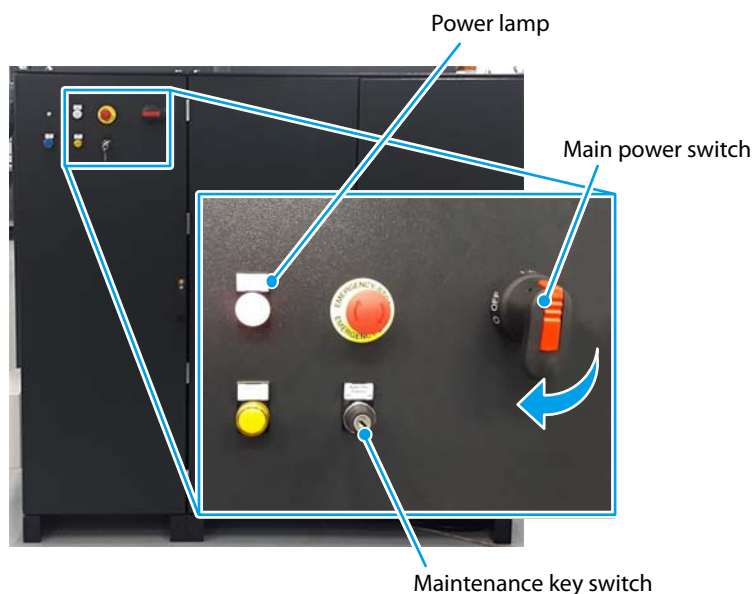

Red on the tower lamp is lit up.

Starting Leonardo

This machine is controlled by Leonardo on a control PC.

- 1 When the power to the machine is turned on, the control PC starts. Wait for Windows to start on the PC.
- 2 The Windows startup screen appears on the display of the control PC. After Windows starts, Double-click the Leonardo icon on the desktop to start Leonardo.

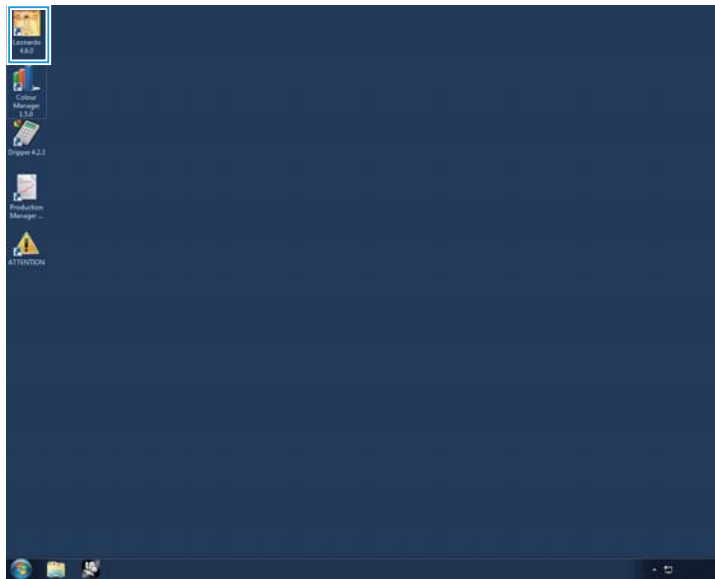

CAUTION

Do not add Leonardo to the Startup settings in the OS. Leonardo may not function properly if added to the Startup settings.

- 3 When Leonardo starts, the "Machine in Emergency" and "Ready to start" messages are displayed on the status bar.

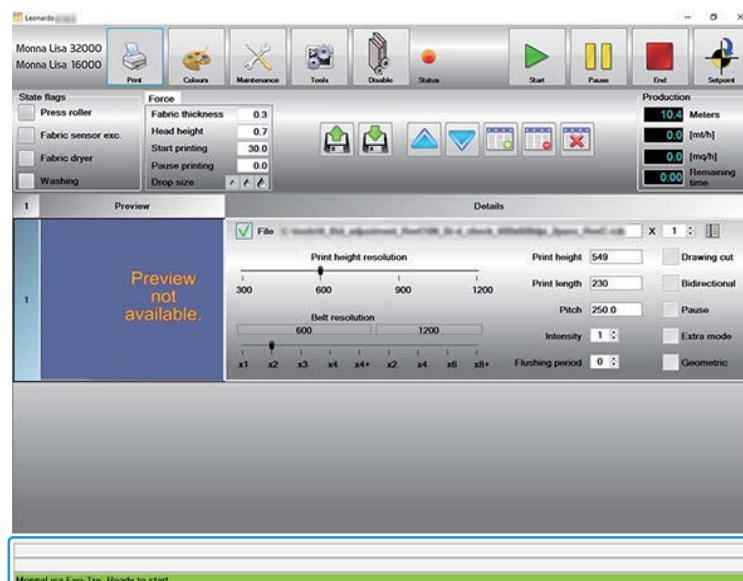

Releasing an Emergency Stop Button

Turn the emergency stop button to the right to release the emergency stop status.



Setpoint cannot be executed if any emergency stop button has been pressed because the emergency stop condition has not been released.

Confirm that all of the following emergency stop buttons have been released.

- Five emergency stop buttons of this machine
- Open the rear cover and pull the blue lever on the left emergency stop rope switch.
- Emergency stop buttons for devices linked to this machine (If there are linked devices)
- Insert the belt cleaning unit straight in its original position.

Executing Setpoint

Set a Setpoint (origin position) before printing in order to print at the correct coordinates.

Immediately after turning on the power, releasing an emergency stop button, replacing fabric, adjusting the print heads, and/or performing head cleaning, be sure to execute Setpoint before printing.

- 1 Click the [Setpoint] icon in Leonardo.



- 2 Press the reset button on the main electric box for one second.

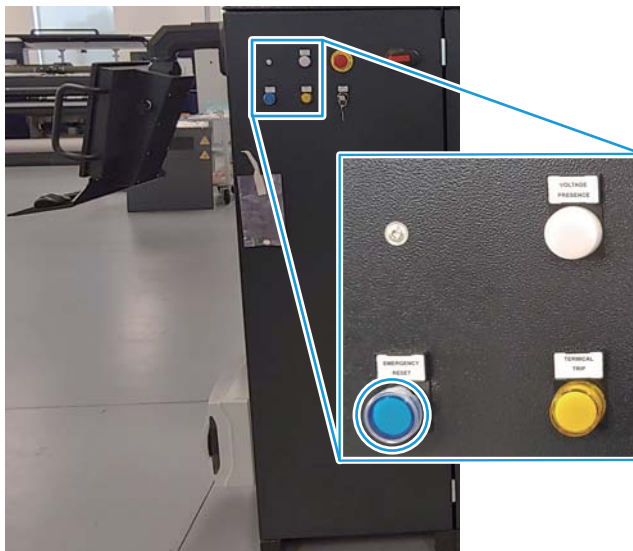

- 3 The print heads move, and the origin position is set. At this time, "Setpoint in progress" is displayed in the status bar of Leonardo and the tower lamp changes to white.

When Setpoint is completed, the tower lamp changes to green.



If the print head does not operate even after executing Setpoint, confirm that all emergency stop statuses have been released. For more information, refer to "[Releasing an Emergency Stop Button](#)" on page 62.

Checking the Operation of the Emergency Stop Equipment

Check all emergency stop functions in the system.

Checking the Emergency Stop Buttons on the Machine

- 1 Press the emergency stop button.
- 2 Confirm that "Machine in emergency" is displayed on the status bar in Leonardo, and that the tower lamp is red.
- 3 Turn the emergency stop button to the right to release the emergency stop status.



- 4 Executes Setpoint.
Refer to ["Executing Setpoint" on page 63](#).
- 5 Confirm that the tower lamp is green.
- 6 There are five emergency stop buttons around the machine.
Repeat procedures 1 to 5 to check the operation of each emergency stop button.

Checking the Emergency Stop Functions in the System

If the system is linked with the emergency stop system of other equipment, check if the system's emergency stop function for that equipment is operating normally.

Inspecting for Leaks in the Ink Path

Inspect if there are any ink leaks in each ink path.

Print head

Visually check the area round the print head on the front of the machine.

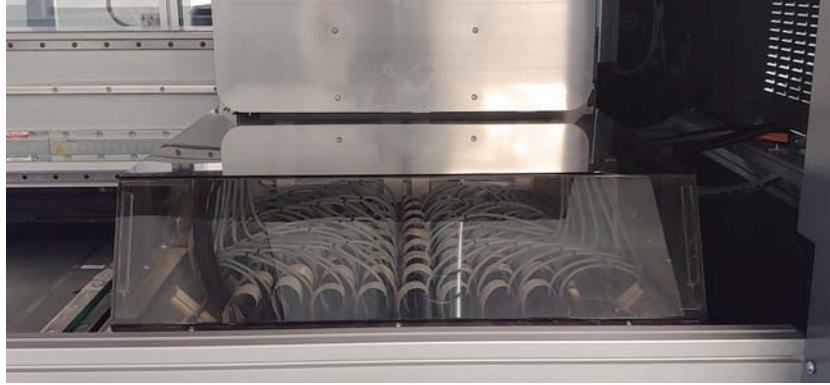

Ink rack

Visually check the area around the ink rack.

3L:



10L:



Inspecting the Open Cover Detection

Front Covers

Open each of the three front covers on the front of this machine and confirm that "Front protection open" is displayed on the status bar in Leonardo.

Rear Cover

Open the rear cover of this machine and confirm that "Rear protection open" is displayed on the status bar in Leonardo.

Nozzle Check

Before printing, perform a nozzle check to make sure that there are no clogged nozzles. If there are clogged nozzles, perform head cleaning.



Use an acrylic board for the nozzle check, because the ink grains are very fine. Fabric can also be used, but makes it difficult to determine if there are clogged nozzles.

Items required:

- Acrylic board
- Ruler / tape measure (to measure the distance from the edge of the print area to the edge of the paper)

Setting the Acrylic Board

This step is not necessary when printing directly on fabric.

- 1 Open the front covers.**
- 2 Affix the acrylic board to the printing area. Affix the acrylic board along the right edge, because the origin of the print heads is on the right side.**



The horizontal printing margin can be set in Leonardo, and therefore it is not necessary to affix the acrylic board precisely to the right edge of the printing area.

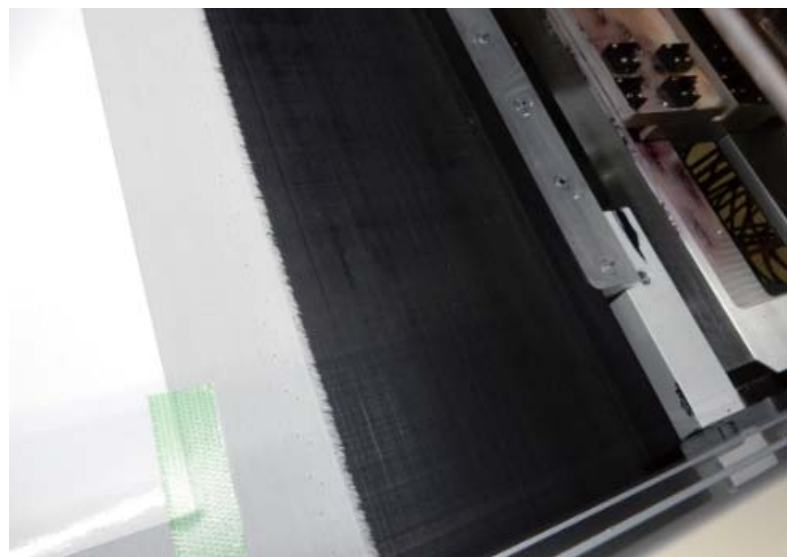

3 Measure the distance from the edge of the belt (right side).

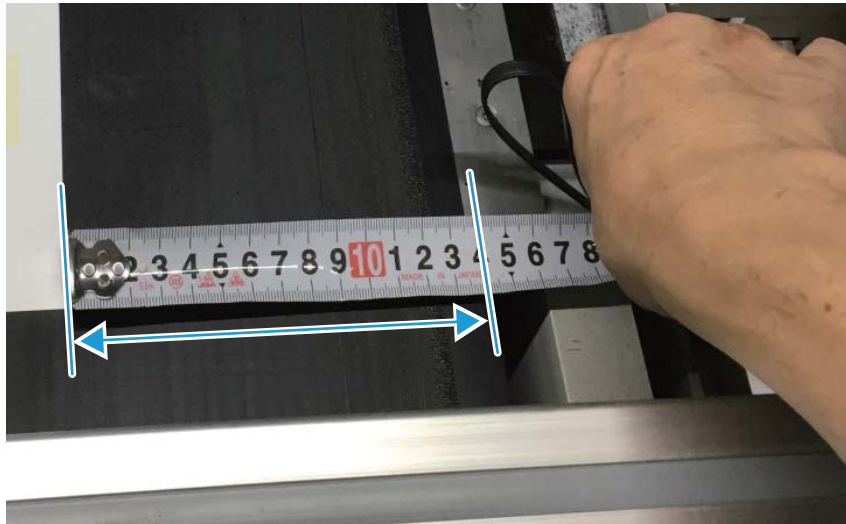

4 Close the front covers.

Printing the Nozzle Check Pattern

Set the print start position and settings in [Maintenance].

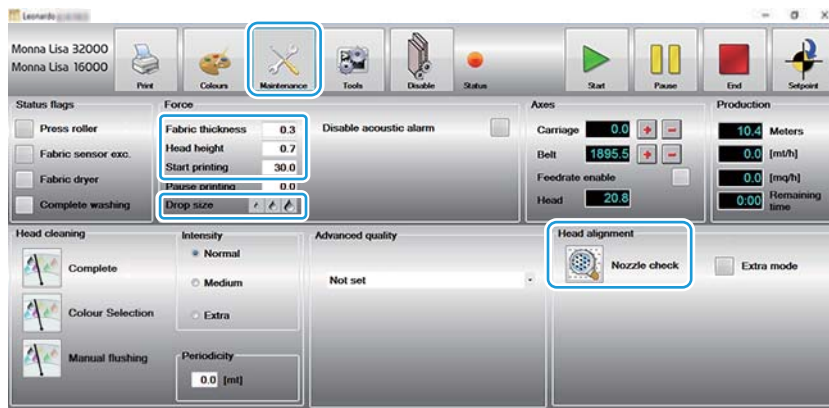

Item	Description
Fabric thickness	Set the fabric and acrylic board thickness.
Head height	Set the print head height.
Start printing	Enter the length from the right edge of the printing area to the point where printing begins. (Units: mm)
Drop size	Select the drop size. Normally, select Large size.
Nozzle check	Prints the check pattern.

Click [Nozzle check] to print the check pattern.

Confirmation Method

Check the nozzle check pattern that is printed.

If there are no clogged nozzles and operation is normal, all of the lines will be printed.

For ML-16000-180 and ML-16000-340

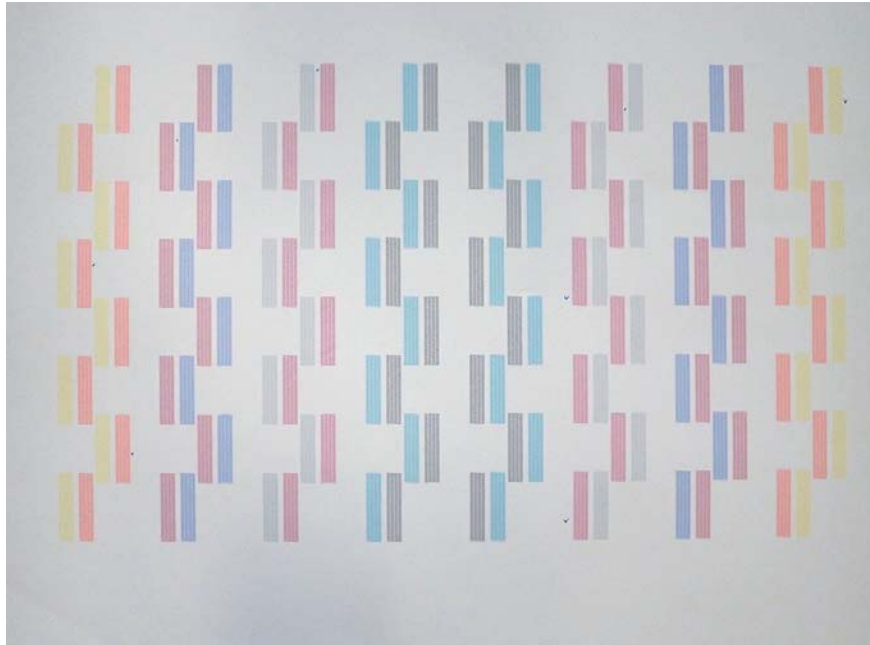

For ML-32000-180 and ML-32000-240

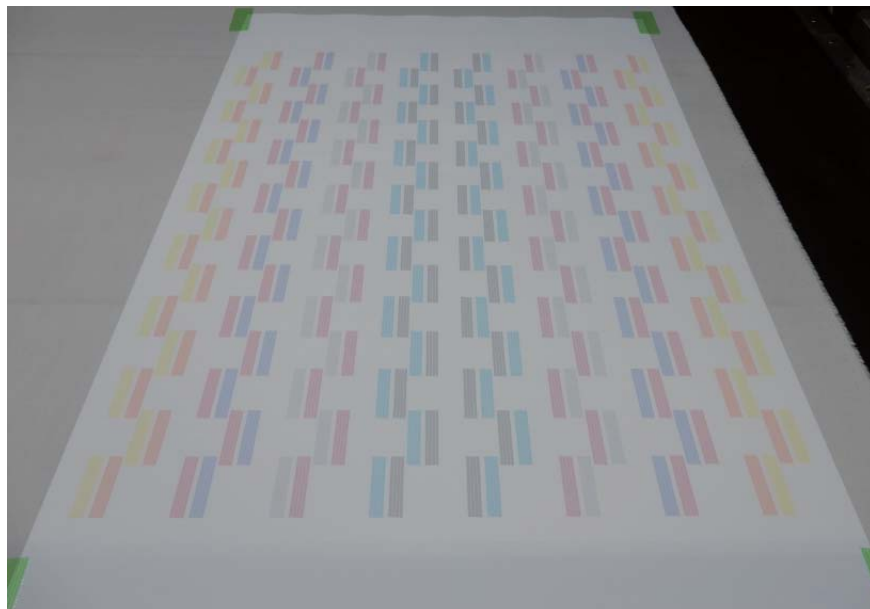

If there are clogged nozzles (there are areas that are not printed), actual printing could be affected. In that case, perform head cleaning.



The nozzle check does not guarantee print quality.

If the nozzle check pattern has mixed colors, perform manual flushing. For more information, refer to "[Manual flushing](#)" on page 137.

Head Cleaning

Use one of the following procedures to perform head cleaning.

- Cleaning with Leonardo (recommended)
- Manual cleaning: Refer to the "Maintenance Guide".

Cleaning with Leonardo

Make the required settings in the [Maintenance] menu to perform cleaning.

1 Click [Maintenance].



2 Under [Intensity], select the strength of head cleaning.

First, perform cleaning in [Normal]. If it does not recover, try cleaning in [Medium]. If it still does not recover, clean in [Extra].

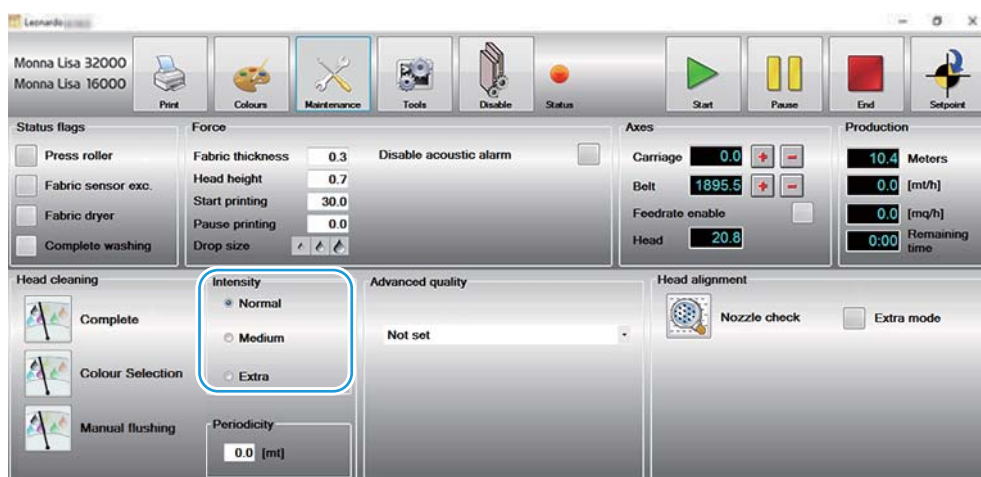

Item	Description
Normal	Use this setting for standard head cleaning.
Medium	Use this setting if the problem is not resolved on the Normal setting. A greater amount of ink is used than for the Normal setting.

Item	Description
Extra	Use this setting if there are bubbles in the ink tube. Because most of the ink in the ink path is discharged, this setting uses a very large volume of ink.

3 Under [Head Cleaning], select the heads to be cleaned, and then start head cleaning.

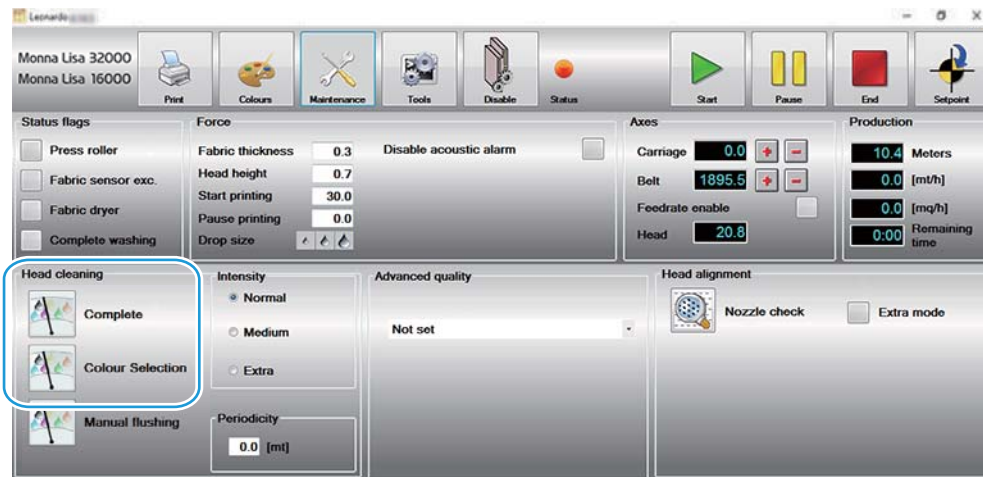

Item	Description
Complete	This setting cleans all of the heads.
Colour Selection	This setting cleans the ink selected for cleaning.

Print Workflow

This section describes the workflow for printing.

Workflow

Setting the Fabric

1. Setting the Fabric ([Page 73](#))
2. Setting the Foreign Material Detection Sensor ([Page 94](#))
3. Setting the Printer ([Page 97](#))

Printing

1. Loading the Print Data ([Page 100](#))
2. Setting the Print Data ([Page 102](#))
3. Printing (Test Print) ([Page 104](#))
4. Adjust Printing (if there are problems, such as resetting the print screens and adjusting connections in the advanced settings)
5. Print (Test Print)
6. Mass Production Printing (when test printing is OK)

Setting the Fabric

Loading the Fabric



WARNING

The fabric must be as smooth and firm as possible. If the fabric edge is fraying and threads are loose, the fiber may come into contact with the print head, damaging the print head. In the same way, be sufficiently careful to prevent protrusions and fraying at the seam between pieces of fabric.

1 Open the rear cover.



WARNING

The machine can operate at a decelerated rate even when the rear cover is open. However, use this only in special circumstances. Be particularly careful to avoid your finger being pulled or crushed by the moving pressure roller.

When you open the rear cover, the machine decelerates for operation, and the rotary beacon light flashes in orange to notify you.

2 Confirm that the pressure roller is lifted up. If the pressure roller is not lifted up, move the pressure roller switch to the left to lift it.

3 Remove the feeding spindle for procedures 3 to 6. Rotate the feeding spindle and align it with the lock release position.

Correct position

Air inlet is visible

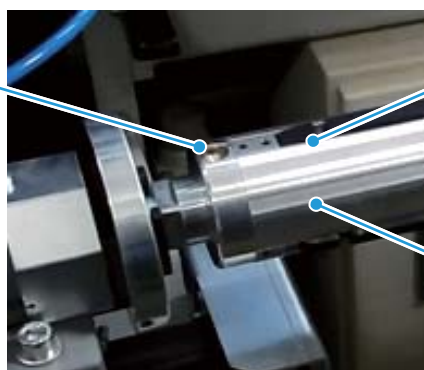

Stopper

Feeding spindle

Incorrect position

Air inlet is not visible

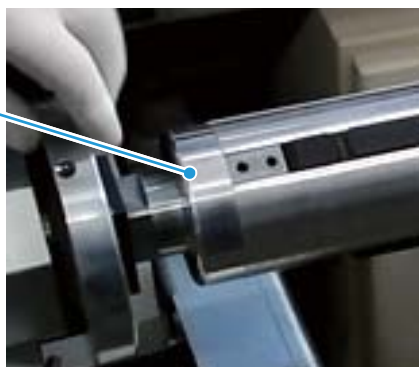

- 4 Press the center of the air inlet of the spindle to release the air and loosen the spindle stopper.
- 5 Release the locks on the left and right sides of the feeding unit. This allows the feeding spindle to be removed.

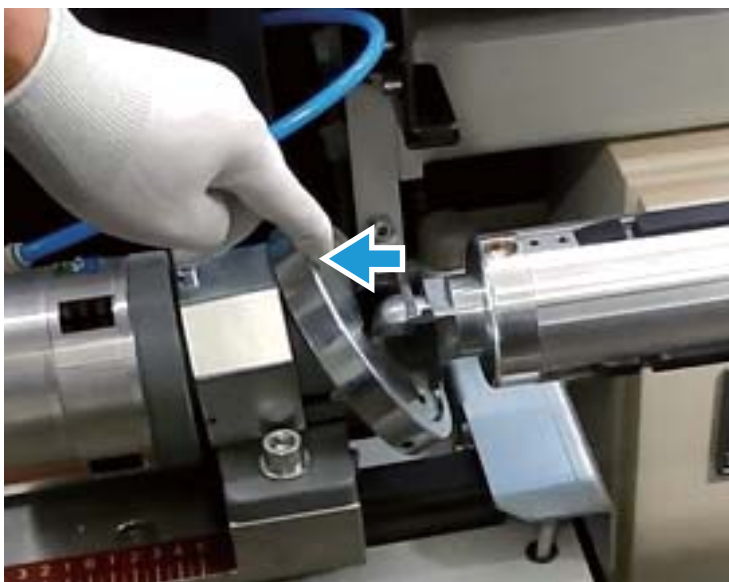

- 6 Remove the feeding spindle, and replace the fabric.
- 7 Set the new fabric on the spindle.

**CAUTION**

Fabric rollers that weigh 20 kg {44.1 lb} or more should be set by two people.

- 8 Set the fabric in the feeding unit. Fit the feeding spindle into the groove on the feeding unit.



9 Lock the feeding spindle.

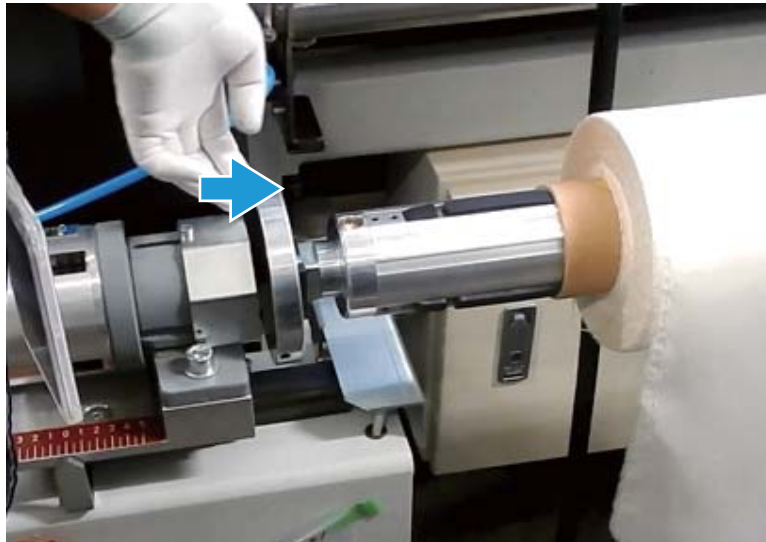

10 Adjust the lateral position of the fabric. Align the fabric center with the printer center.

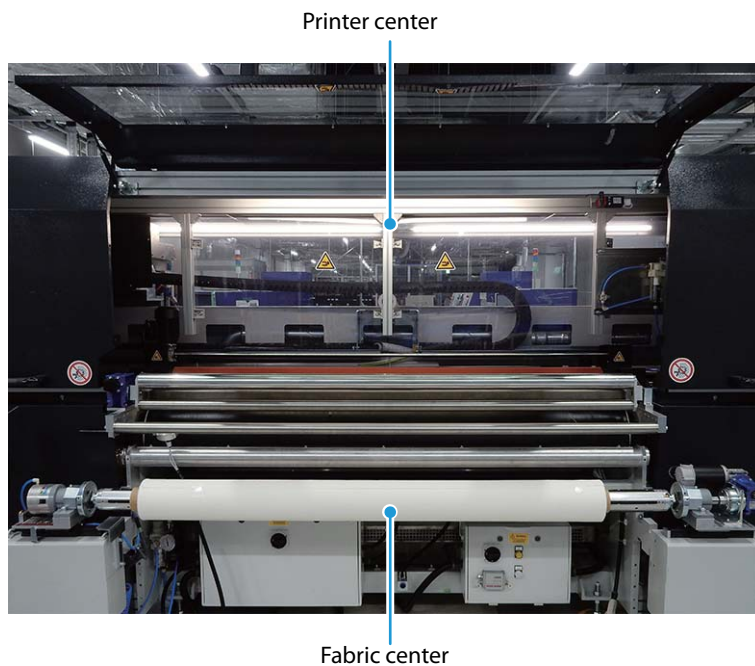

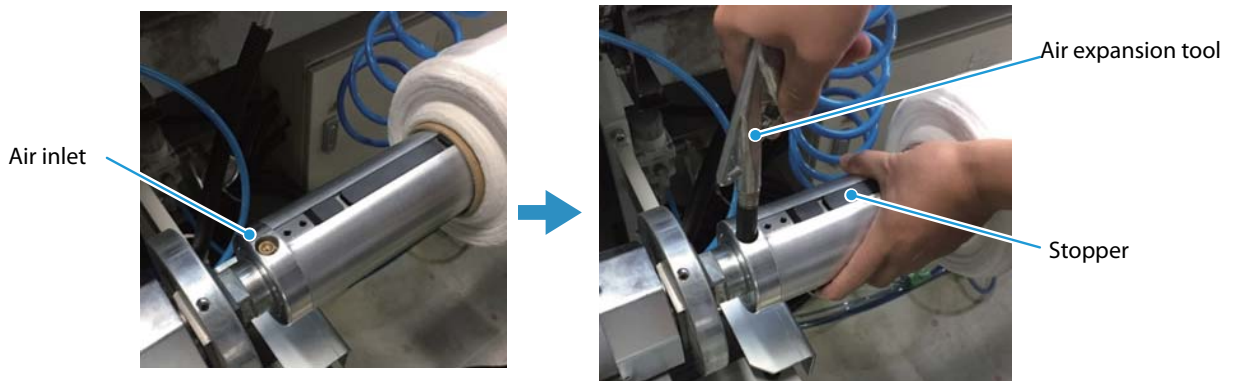

11 Insert the air inflation tool into the air inlet and inject air. The stopper on the spindle swells to fix the fabric.



12 Feed the fabric through the roller.

The fabric path varies depending on the roller installed.

 <p>WARNING</p> 	<p>Keep your hands away from the following moving parts while the machine is operating. Otherwise, there is a risk of your hands, hair, or clothing becoming caught in the machine.</p> <ul style="list-style-type: none"> • Between the fabric guide bar and the fabric • Fabric feeding belt • Pressure roller
---	--

Dewrinkling roller (Standard)

Image

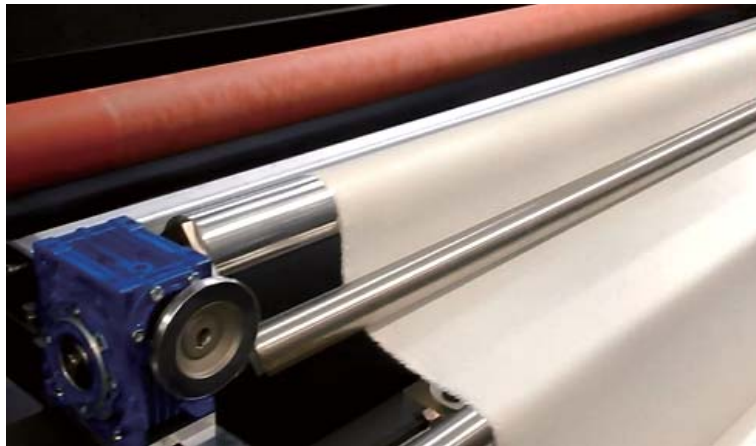

Cross-section of fabric path

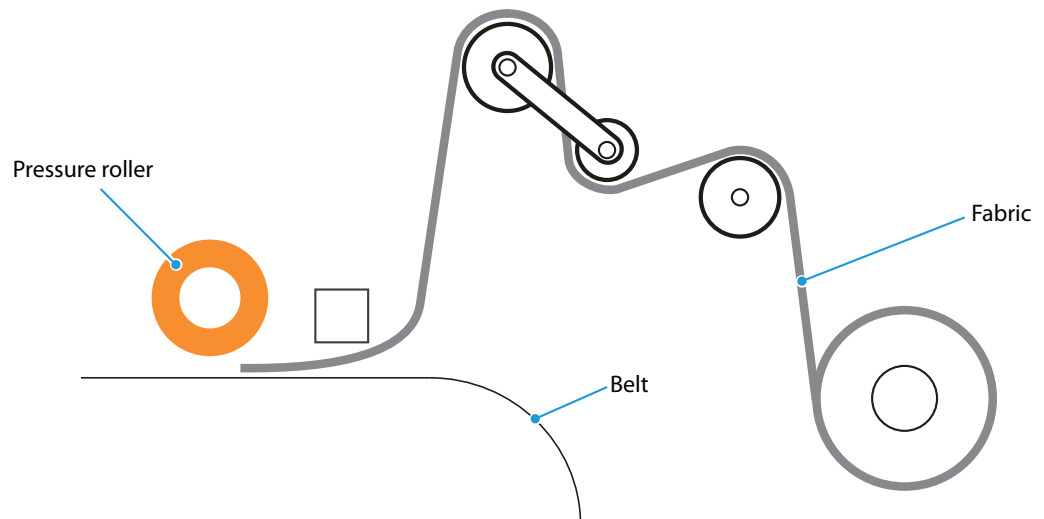

Tension roller (Option)-Using the tension roller

Image

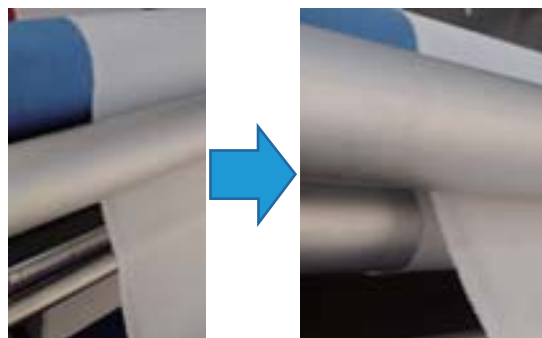
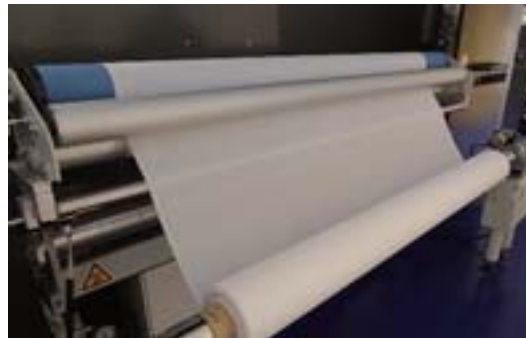

Cross-section of fabric path

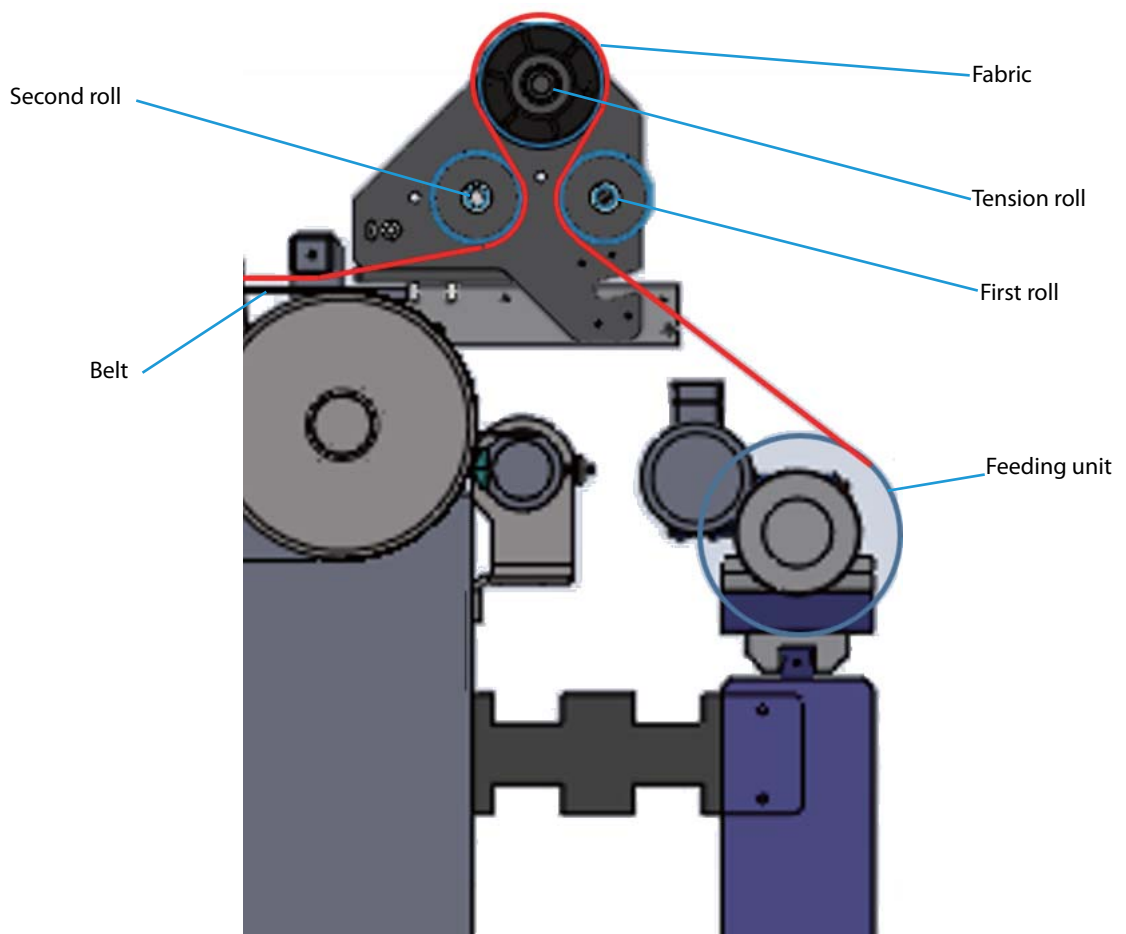

Tension roller (Option)-Slack mode

Image



Do not pass the fabric through the tension roller.



After affixing the fabric to the belt



Cross-section of fabric path

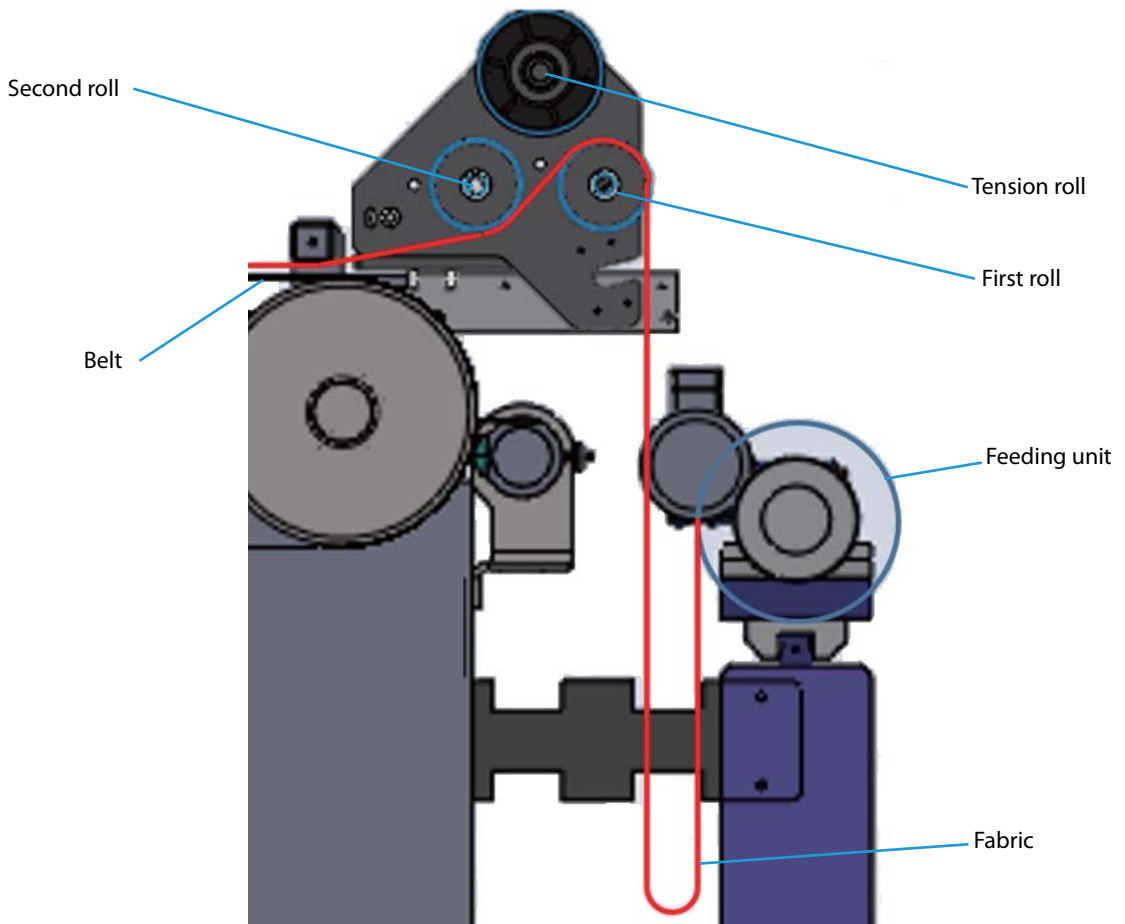

13 Affix the fabric to the belt.

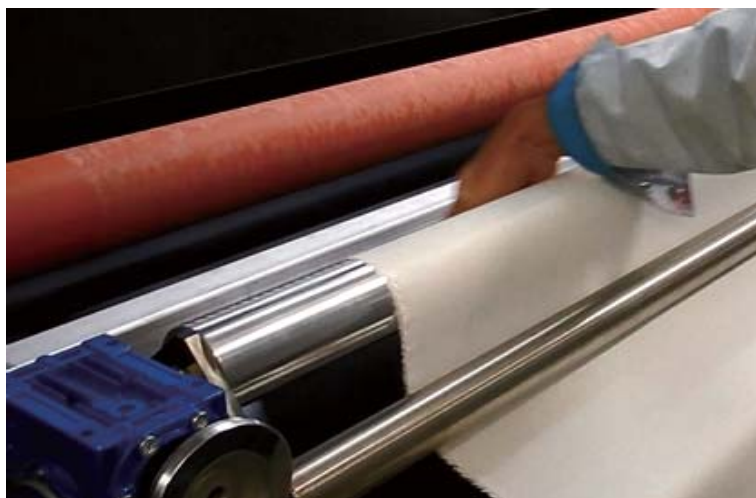

14 Press the feed button on the rear panel to feed the fabric to the edge of the pressure roller.

15 Turn the pressure roller switch to the left to lift up the pressure roller.

16 Turn the feeding unit tension switch on the fabric tension adjustment panel to the right to lock the spindle. The spindle does not move even if the fabric is pulled.

17 Pull the fabric from the front of the pressure roller to remove any slack in the fabric on the left and right.

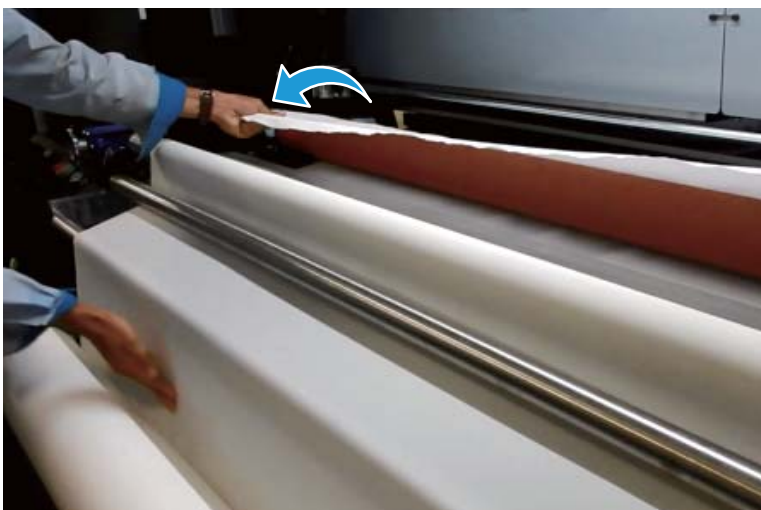

18 Turn the pressure roller switch to the left and lower the pressure roller.



WARNING

The descent speed of the pressure roller is slow, and it comes down gradually. However, be sufficiently careful not to place your hands or fingers under the roller.

19 Affix the fabric that was pulled from the top of the pressure roller to the belt.

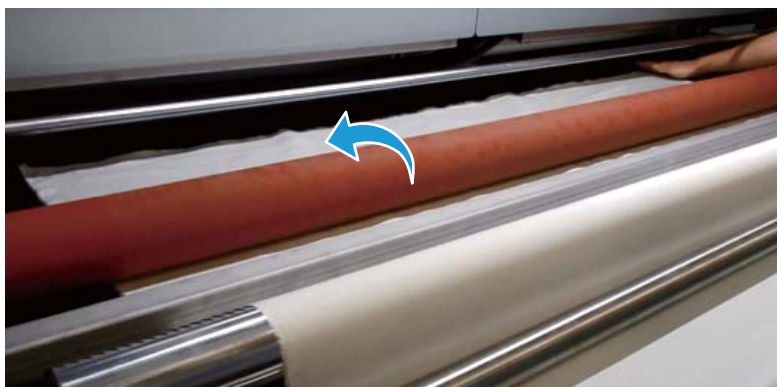

20 Close the rear cover.

21 Turn the pressure roller switch to the right so that the fabric is affixed to the belt, without any areas where the fabric has lifted up. Move the pressure roller forward and back to affix the fabric to the belt.

This completes the work on the rear. Next, perform the work on the front.

22 Press the feed button to feed the fabric forward.



23 Install the fabric on the winder. Feed the fabric as necessary.



If there is enough length in the fabric edge, feed the fabric until the dryer and hold the fabric edge down with the roll core installed in advance on the take-up device or take-up unit. (If taking up, use adhesive tape.)

This completes the procedure for installing the fabric.

Dewrinkling the Fabric

Adjust the tension applied to the fabric to dewrinkle the fabric before printing.

Use the dewrinkling roller handle to change the angle of the dewrinkling roller and adjust the tension applied to the fabric.



- 1 For the ML-16000-340, unlock the lock lever for the dewrinkling roller.

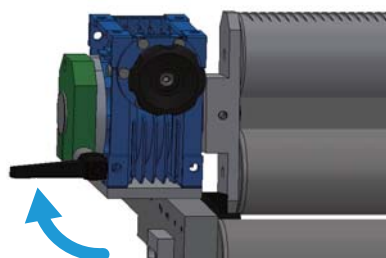

- 2 Turn the dewrinkling roller handle to adjust the tension applied to the fabric. Turning toward (a) reduces the tension applied to the fabric. Turning toward (b) increases the tension applied to the fabric.

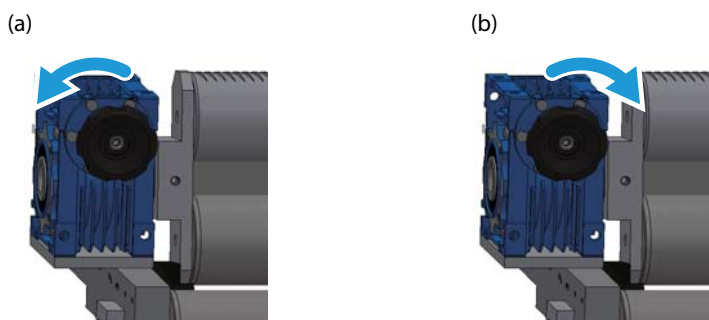

- 3 For the ML-16000-340, lock the lock lever for the dewrinkling roller.

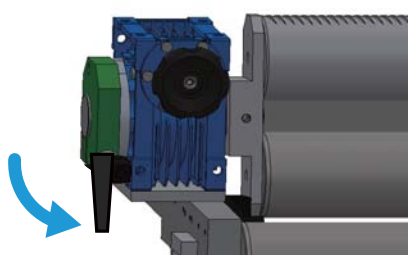

Slack Mode

Printing on knits and other fabrics that stretch and shrink can cause the fabric to be pulled and stretched. Use slack mode when printing on fabrics that stretch and shrink.

	<p>In the following cases, slack mode might not function correctly because the sensors fail to detect the slack part of the fabric when it sways from moving air.</p> <ul style="list-style-type: none"> • When moving air is generated around the machine due to exhaust from peripheral devices or the passage of people • When printing on thin fabrics <p>Under such conditions, put a core into the slack of the fabric to prevent the fabric from swaying. Use a core that is heavy enough to prevent the fabric from stretching. If the core is too heavy, the fabric will stretch and wrinkle when printing.</p>
---	--

1 Turn on the power at the electric box on the left rear side of the machine.

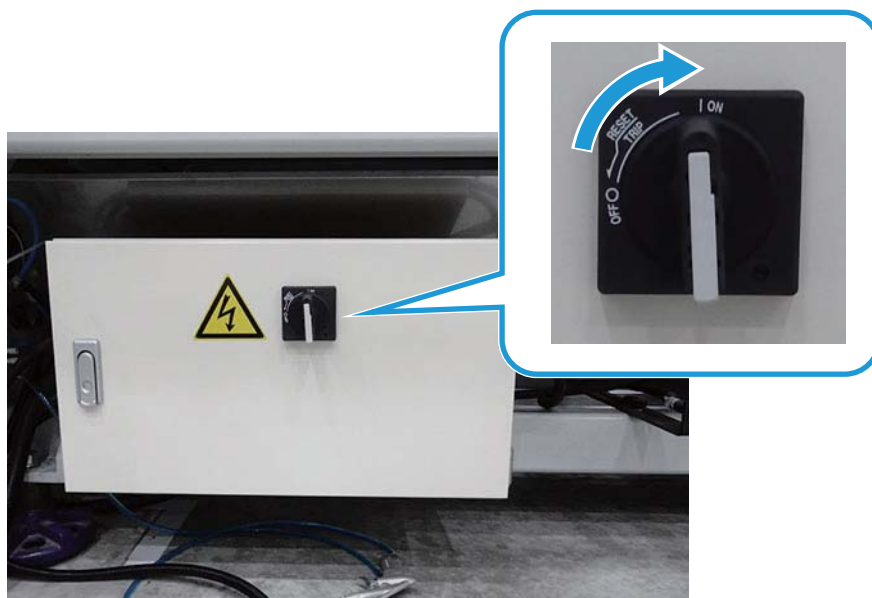

2 Press the feeding unit button (On) on the rear panel.
The button lights up.



- 3** Turn the slack detection switch to On.
The switch lights up.



- 4** Turn the feeding unit tension switch on the fabric tension adjustment panel to the right to turn on fabric tension adjustment.



- 5** Load a fabric roll onto the feeding unit.
For more information, refer to ["Setting the Fabric"](#) on page 73.
- 6** Turn the tension adjustment dial on the fabric tension adjustment panel to the right, adjusting the fabric tension until the spindle does not rotate from the weight of the fabric roll and the fabric can be pulled out without resistance.



7 Put the core into the slack of the fabric.



8 When printing on the inner side of the fabric, turn the slack adjustment switch to the left. When printing on the outer side of the fabric, turn the slack adjustment switch to the right.

The spindle for the feeding device will rotate and the fabric will begin to have slack.

The following procedures describe how to print on the inner side of the fabric.

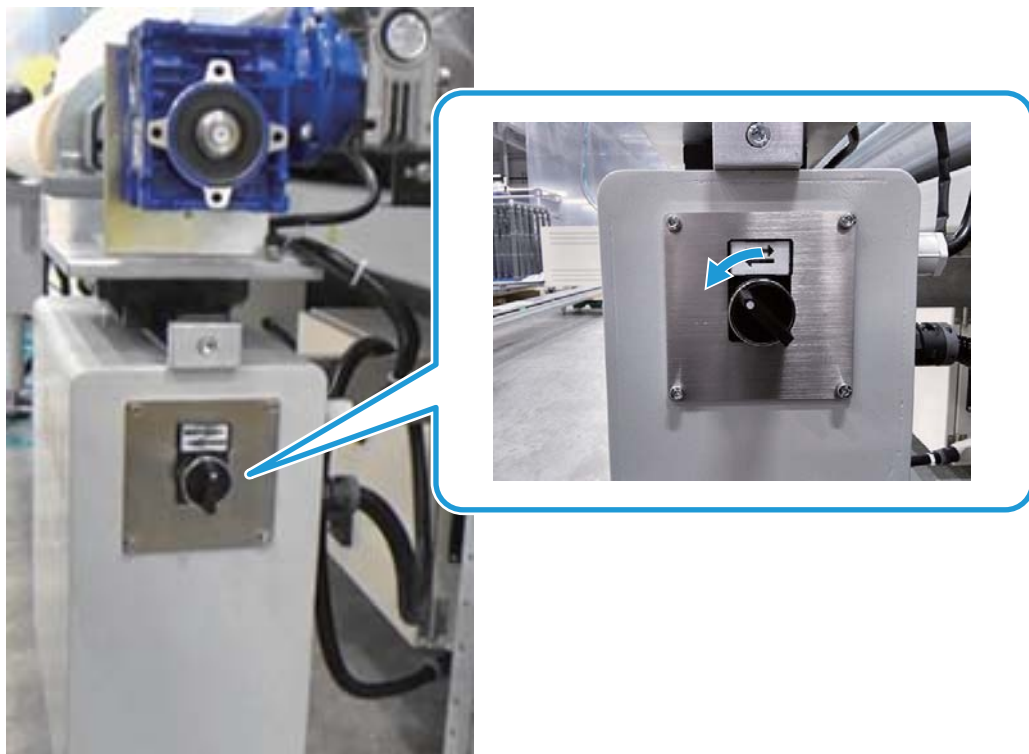

9 When the fabric hangs down to the height of the slack sensor, the machine automatically stops.

The amount of slack is detected by the slack sensor in the rear lower center. If the belt moves and lifts up the fabric causing there to be not enough slack, slack is given to the fabric until the sensor detects the fabric.

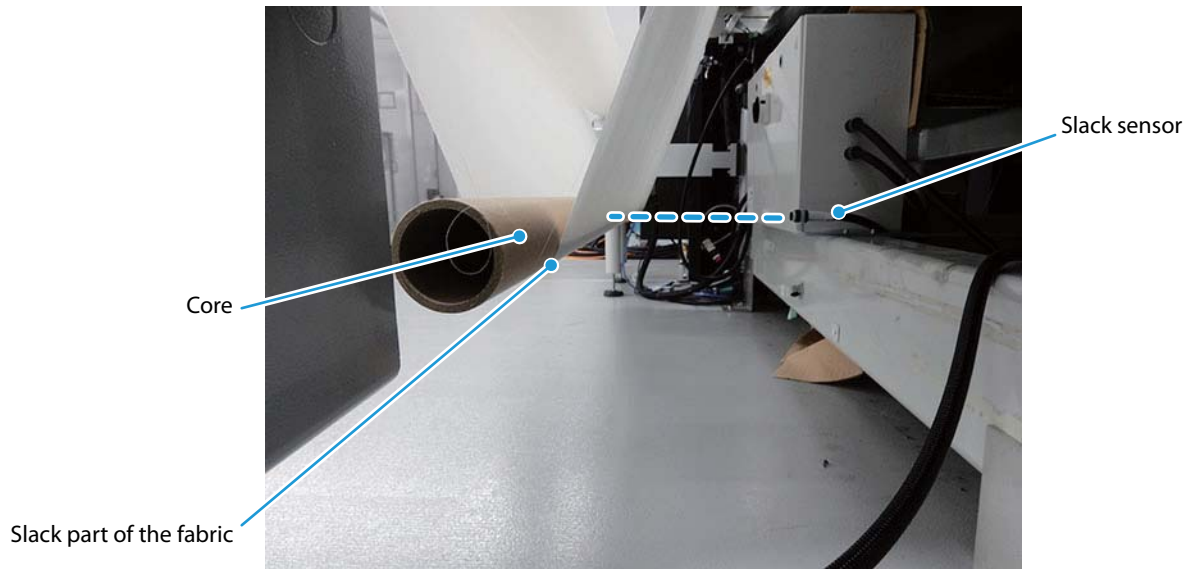

When the slack sensor does not detect the fabric

If the machine does not stop automatically even though the fabric hangs down to the height of the sensor, the fabric might be too far from or too close to the sensor. Adjust the distance between the sensor and the fabric.

1 Turn the slack adjustment switch to the center.

Slack mode stops.

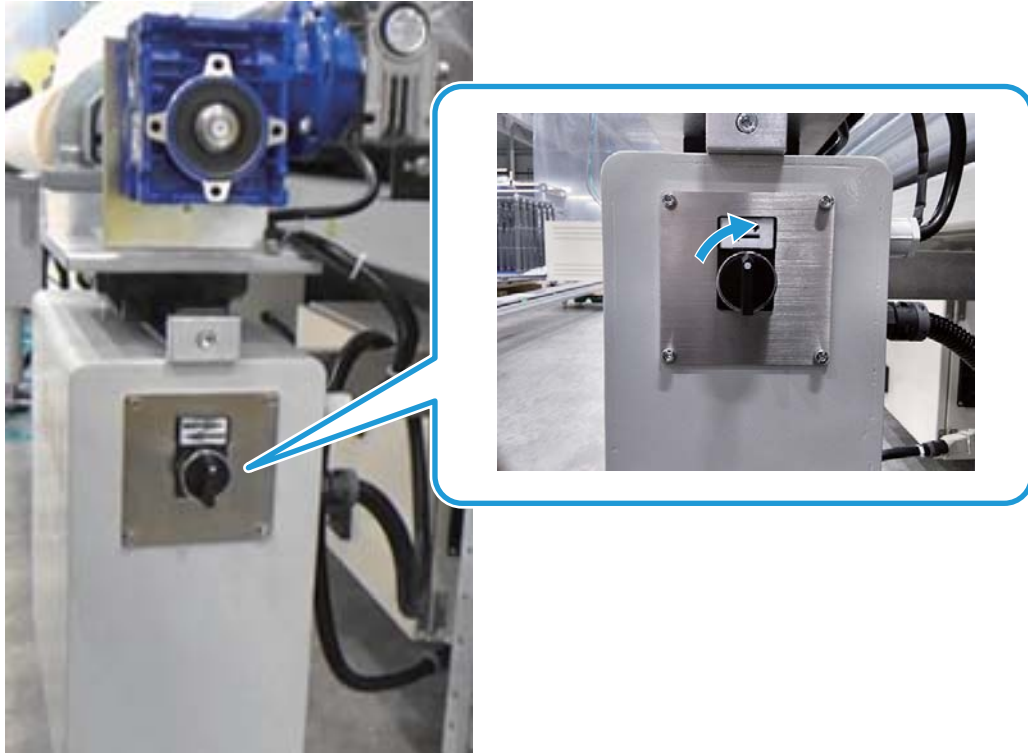

2 Loosen the two knob screws on the slack sensor.



- 3** Adjust the distance between the slack sensor and the fabric to between 50 and 150 mm {1.97 and 5.9 in}.



- 4** Tighten the two knob screws on the slack sensor.
- 5** Turn the slack adjustment switch to the left.
The spindle for the feeding device will rotate and the fabric will begin to have slack.

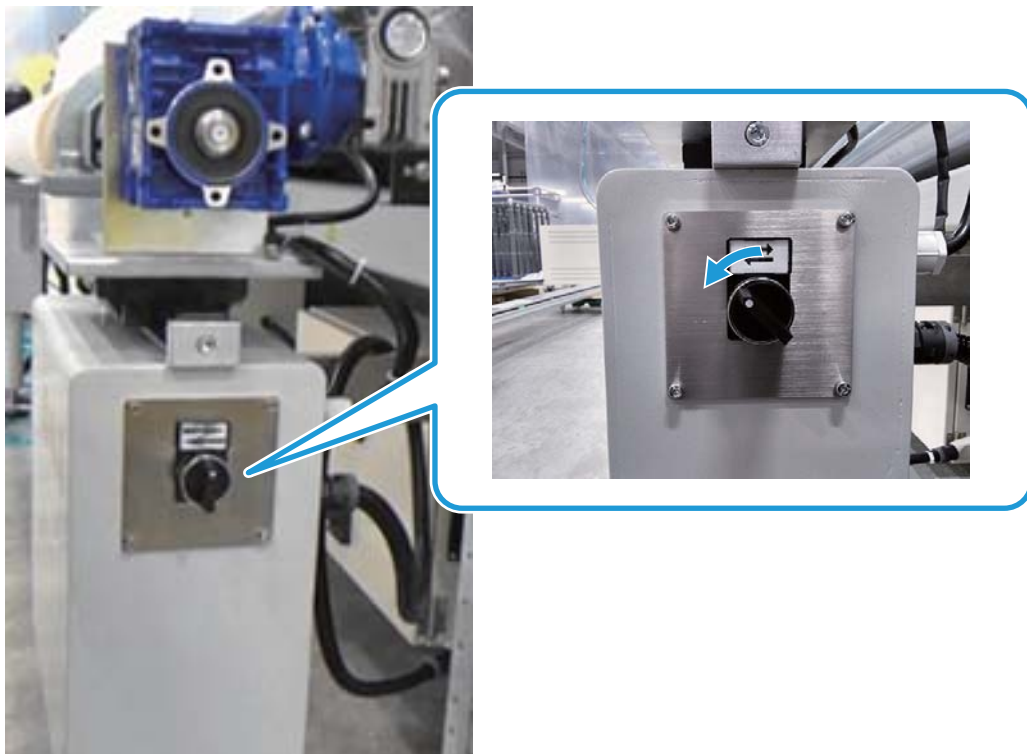

- 6** Confirm that the machine automatically stops when the fabric hangs down to the height of the slack sensor.

Fabric Meandering Correction

If you load a fabric roll with uneven edges, the fabric will meander. Either wind the fabric again or follow the procedures below. If the unevenness for edges of the fabric is severe, wind the fabric again.

- 1 Turn on the power at the electric box on the left rear side of the machine.

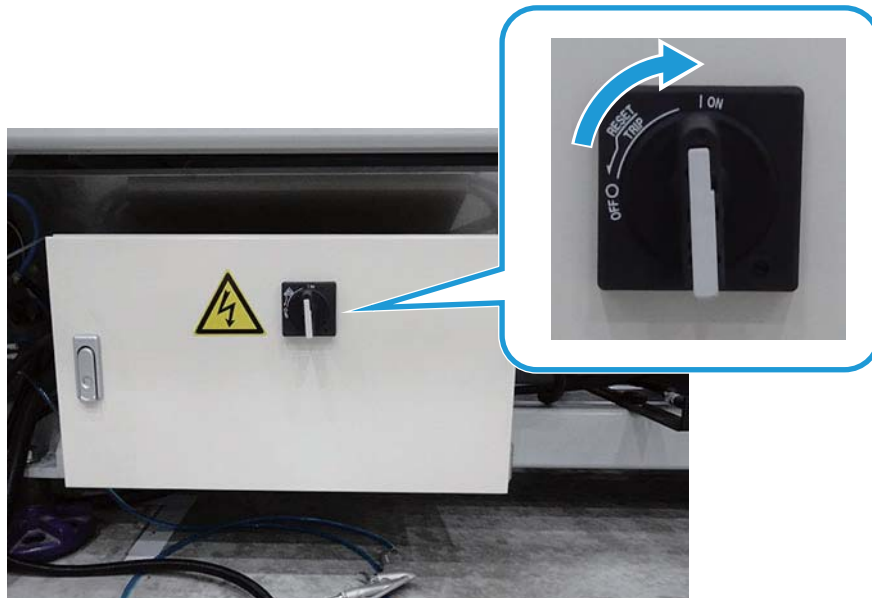

- 2 Press the feeding unit button (On) on the rear panel.
The button lights up.



- 3** Turn the fabric position adjustment switch (Auto) on the rear panel to Man.



- 4** Use the fabric position adjustment switch (LR) to set the memory of the feeding unit to 0.



5 Adjust the position of the fabric edge sensor unit so that the left edge of the fabric is centered between the two sensors.

Loosen the knob screw to move the fabric edge sensor unit to the left or right. Align the fabric edge sensor unit with the left edge of the fabric, and then tighten the knob screw to secure it.

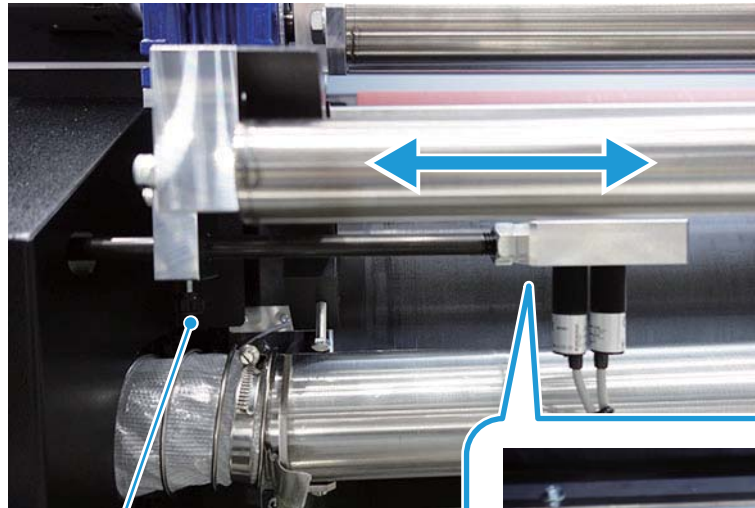

Knob screw

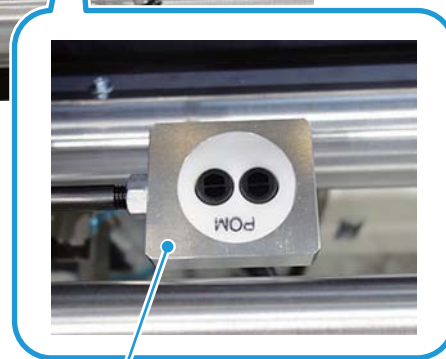

Fabric edge sensor unit

Left edge of the fabric

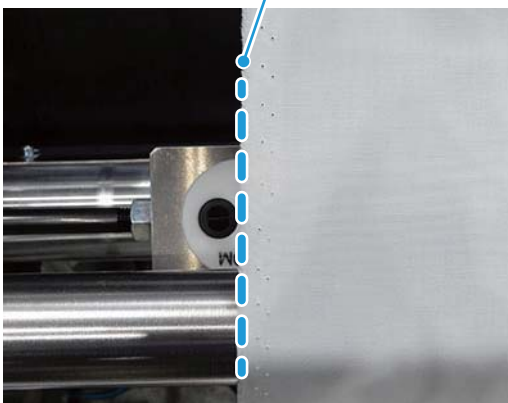

- Turn the fabric position adjustment switch (Auto) on the rear panel to Auto. The meandering of the fabric is automatically adjusted when printing starts.



Precise correction of meandering fabric

Use the following procedures to more precisely correct meandering fabric.

- Use a hex wrench (2.5 mm {0.1 in}) to loosen the sensor adjustment screw.

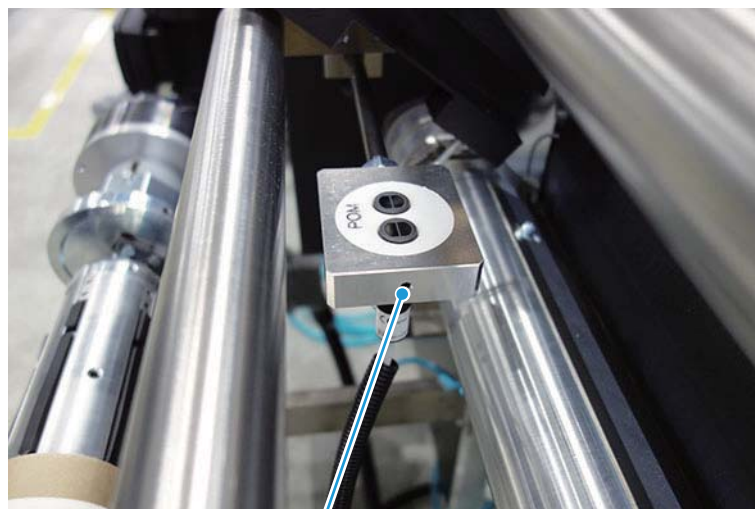

Sensor adjustment screw

2 Rotate the fabric edge sensors to the right to make the detection range more narrow.



Do not rotate the sensors more than 90° to the right. Otherwise, the sensors will be switched left to right, and it will not be possible to correct meandering.

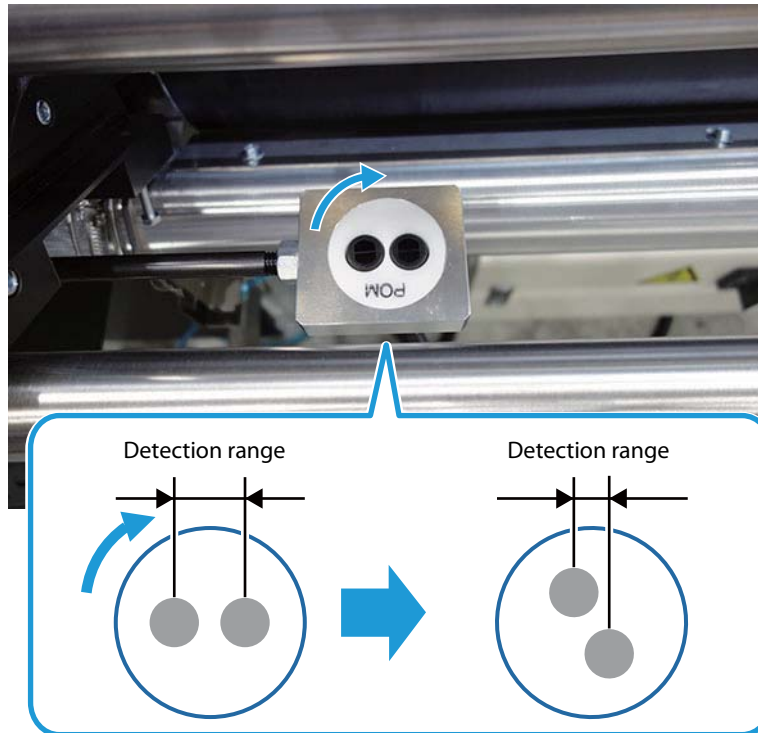

3 Use a hex wrench (2.5 mm {0.1 in}) to tighten the sensor adjustment screw.

To return the sensors to the original detection range, rotate the fabric edge detection sensors to the left.



Do not rotate the sensors to the right. Otherwise, the sensors will be switched left to right, and it will not be possible to correct meandering.

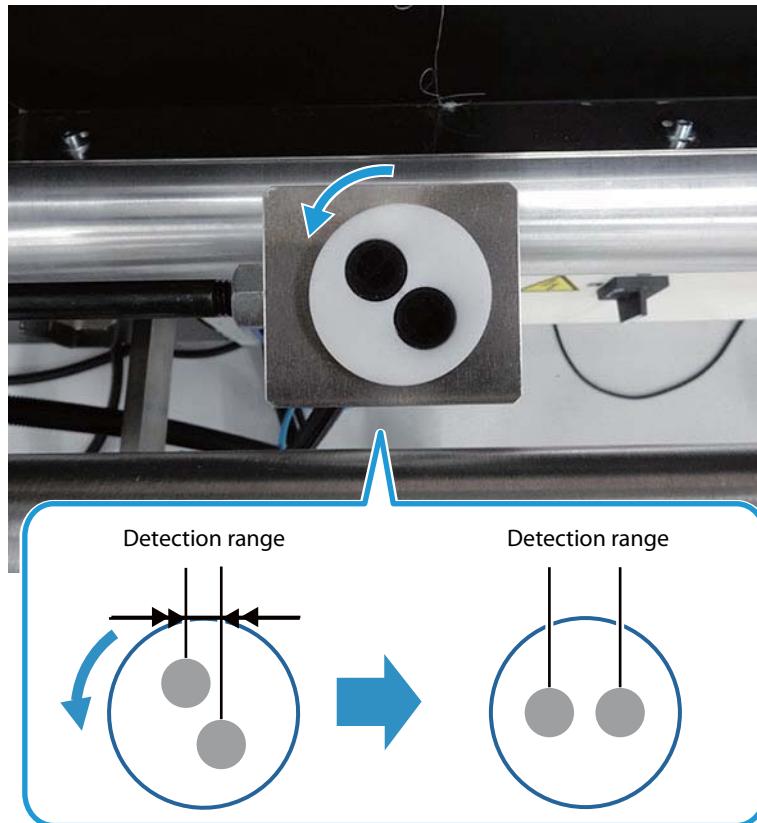

Setting the Foreign Material Detection Sensor

Set the foreign material detection sensor.

Located at the side of the belt, that detect gaps of the fabric thickness with a laser beam. If there is foreign material on the fabric or if the fabric lifts up or folds over without pressing against the belt, printing is stopped to prevent the print head from colliding with the foreign material or fabric. This threshold value is set by the user.

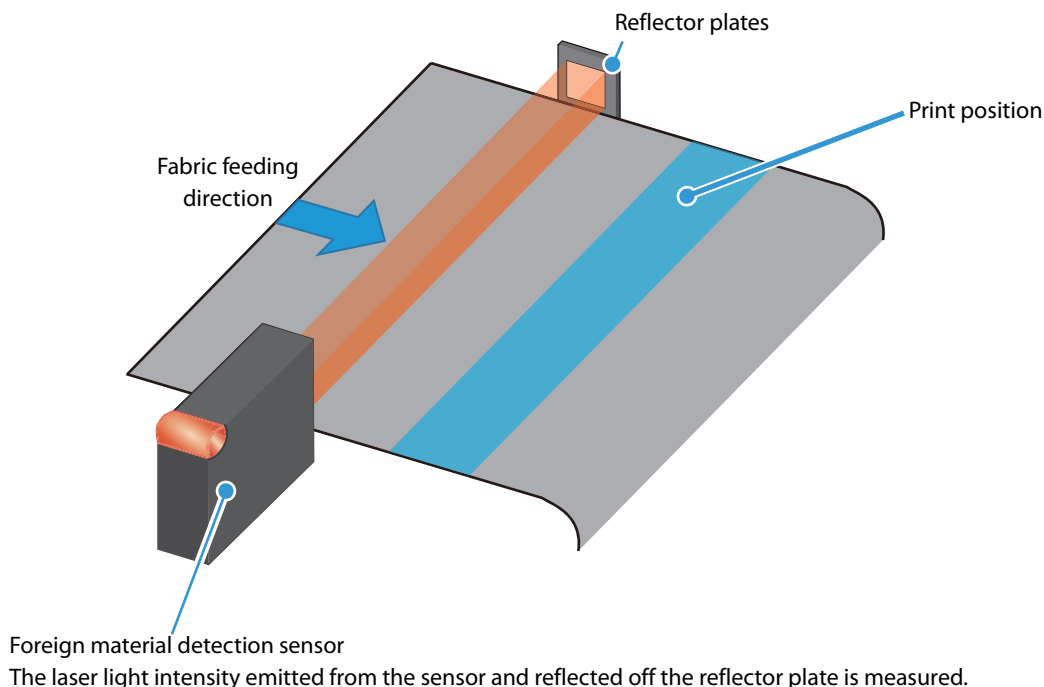

	<p>To prevent print head damage, set appropriately.</p>
	<p>Sensors are located on the left and right sides of the print head carriage. When foreign material is detected, the machine stops.</p>

How to Set the Foreign Material Detection Sensor

Set according to the following procedure.

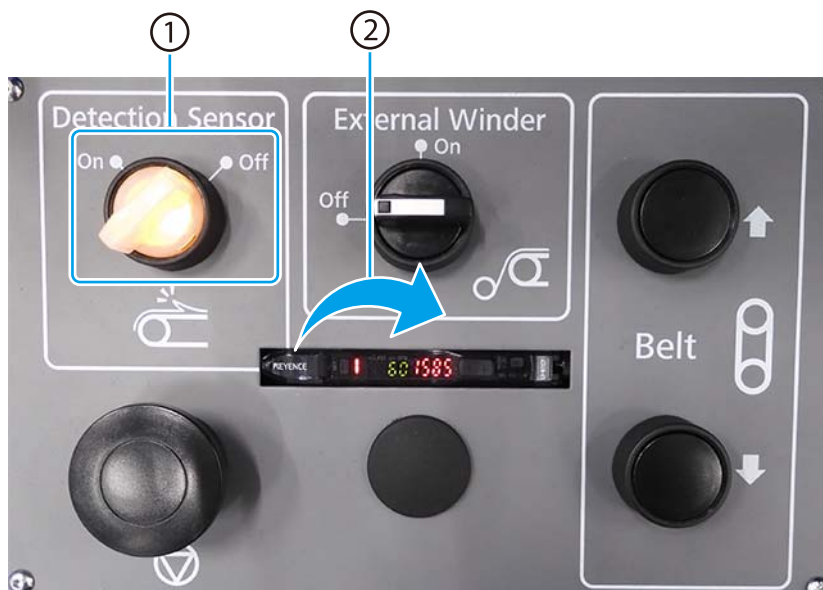

- 1 Turn the foreign material detection sensor switch on the front panel to On.



CAUTION

Normally, leave the foreign material detection sensor On. If this function is disabled, a collision with foreign material on the fabric may cause a head failure. Head failures due to collisions are not covered by the warranty, even during the product warranty period.

- 2 Open the cover on the foreign material detection sensor controller.

(3) Fabric is not set.

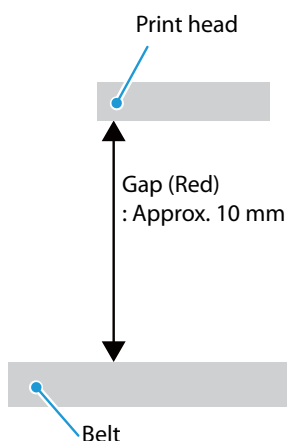

Counter values
 • Red: 9999
 • Green: -

(4) Fabric is set.

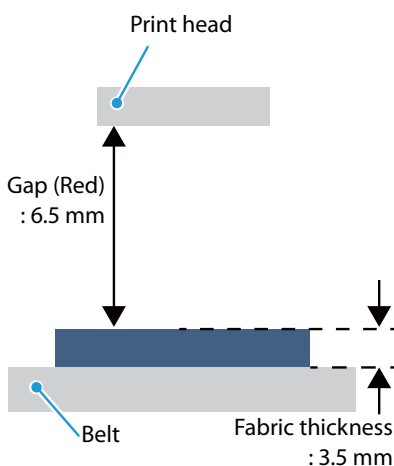

Counter values
 • Red: 6500
 • Green: -

(5) Threshold value setting

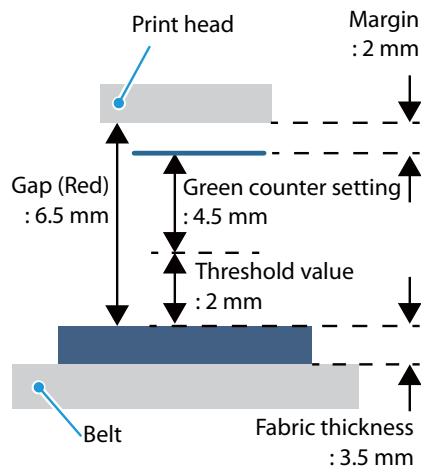

Counter values
 • Red: 6500
 • Green: 4500

- 3** If the fabric is not set, the red counter will show 9999. This shows there is a gap of about 10 mm. Values may vary depending on the condition of the belt. If the fabric is set, the red counter displays the gap between the print head and fabric.

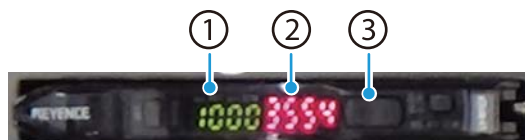

No.	Name	Description
1	Green counter	This is the setting for the threshold value. If detected value falls below this number, an error occurs and printing stops.
2	Red counter	Displays the height of the fabric, measured with a laser.
3	Selector	Use the selector to set the height. Press + to increase the value for the green counter, and press - to decrease the value.

- 4** Press the + or - of the selector to set the threshold value. The value is displayed by the green counter. The difference between the red counter and green counter is the threshold value.

	Recommended setting: Set a value that is 2000 less than the red counter. Setting example: If the red counter is set to 4500, set the green counter to 2500.
---	--

- 5** Close the cover on the foreign material detection sensor controller.

Setting the Printer

Configure the settings in the Print menu.

Set the Fabric Thickness and Head Height

Set the fabric thickness and print head height according to the fabric that is used.



Fabric thickness

Since ink is discharged while the print head moves at high speed, the ink dot position will change according to the distance from the print head to fabric surface.

With bidirectional printing, the ink lands at the height position set with [Fabric thickness]. If this height is not correct, the inkdot feeding position will differ depending on whether printing is from the left or right, causing print quality to drop. Therefore, it is extremely important to ensure that the [Fabric thickness] setting matches the fabric thickness.

The figures below show the ink dot positions when the [Fabric thickness] is incorrect versus when it is correct. When the [Fabric thickness] is correct, the ink dot positions will be uniform, resulting in high-quality printing.

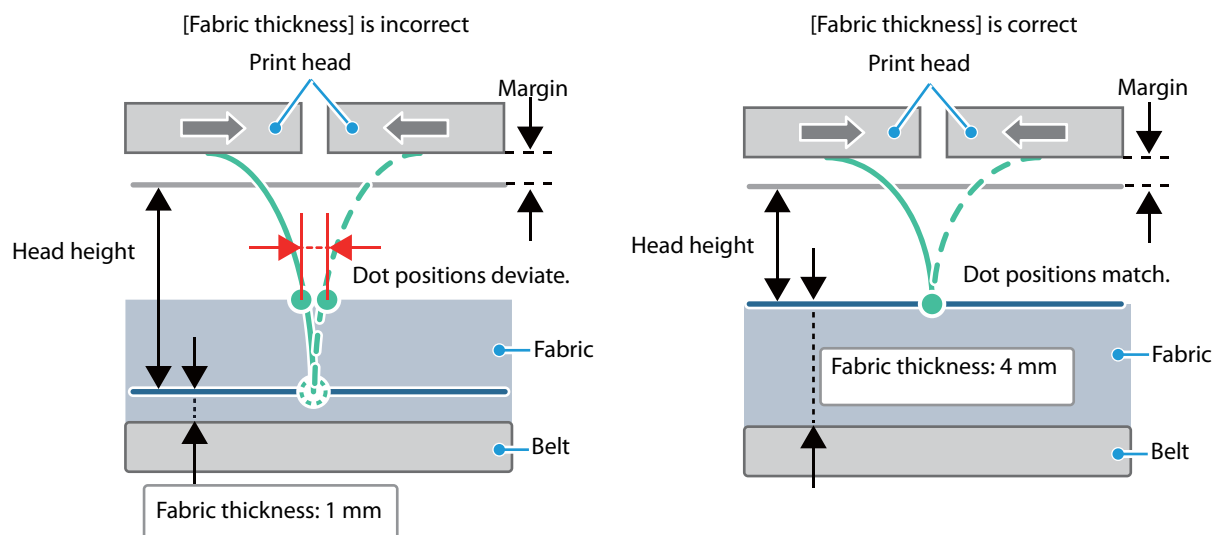

Head height

This setting adds the distance from the print head to the belt. Use it to set a safe distance from the fabric surface so that the print head will be protected.

Set it to protect the print head from fluff generated from the fabric and from fabric edge (ear) processing.

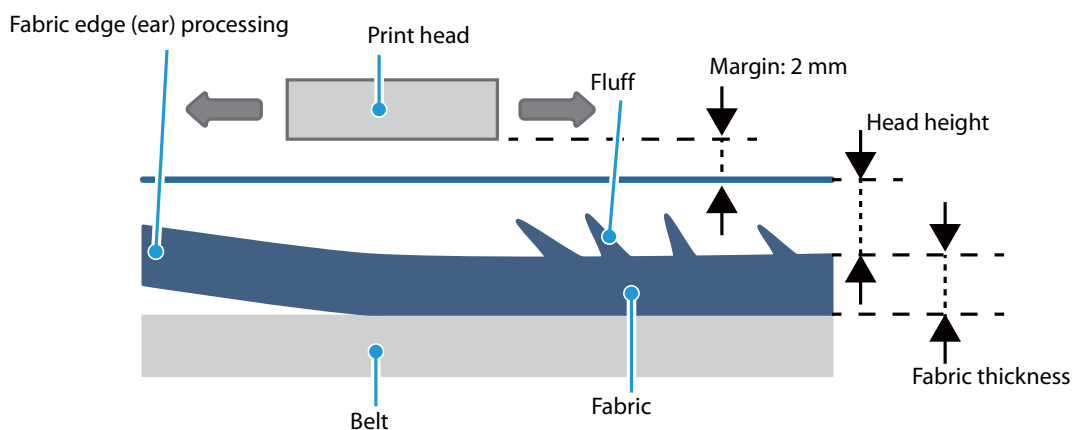

Up to 10 mm can be set in total for [Fabric thickness] and [Head height].

Giving a 2 mm margin to this value, the print [Head height] is a maximum of 12 mm.

Recommended [Head height] setting:

- High quality: 0.7 mm
- Stable operation: 2.0 mm



- Appropriate values for [Head height] will vary according to the type of fabric used.
- If the [Head height] setting is large, the gap between the print head and fabric surface will be large, possibly generating ink mist. For optimal adjustment, we recommend that you take the fabric type and thickness into account.
- If the [Head height] setting is small, the print head might collide with the fabric when the fabric floats upward, causing print head failure or clogged nozzles.
- Manufacturer declines any responsibilities if the operator does not respect all the necessary precautions to keep safe the main printing components also during these operations.

Set the Printer Equipment and Sensors

Set the printer.

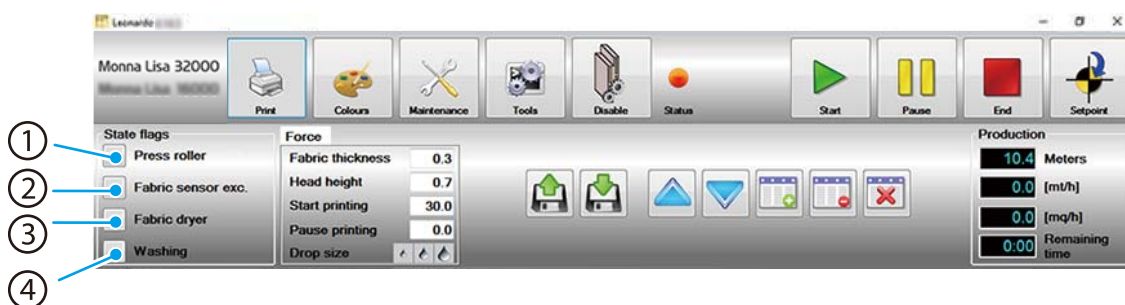

No.	Name	Description
1	Press roller	Select this flag to operate the pressure roller. This flag is selected automatically when printing is in progress.
2	Fabric sensor exc.	Select this flag to disable the foreign material detection sensor. This flag is unselected automatically when printing is in progress. This is enabled only when the foreign material detection sensor switch is On. (Page 43)
3	Fabric dryer	Select this flag to send a signal notifying an external device (external winder, dryer, etc.) of printing. This flag is selected automatically when printing is in progress.
4	Washing	Select this flag to operate the belt cleaning system.



CAUTION

If the printer is stopped for a long period of time, disable the belt cleaning system. Otherwise, damage the belt.

Loading the Print Data



To load print data into Leonardo, first copy the job files to a user-defined folder on the control PC. We recommend creating a folder named "Design" or something similar on the desktop of the control PC. To load job files from USB memory, connect the USB device to the USB port on the back of the display. To remove the USB memory from the control PC, perform the correct Windows operation to safely remove hardware.

1 Click [Load file] in the Print menu.



2 Follow the on-screen instructions to select a job file.
 The information for the file that is loaded is displayed in the [Print] menu.

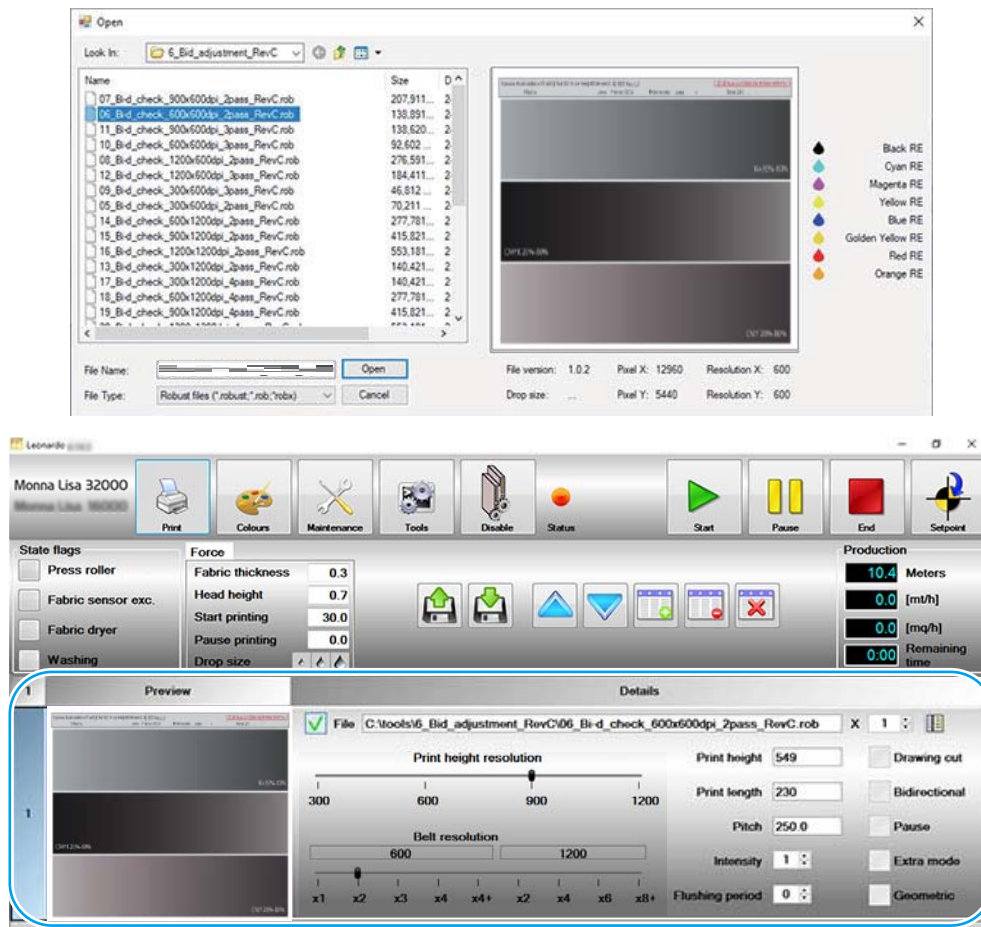

There is a character limit for file names. When adding data, if the message is displayed but the file information is not displayed, reduce the number of characters in the file name, including the path, displayed for [File name] on the [Load file] screen. When using ASCII characters, limit the input to 251 characters.

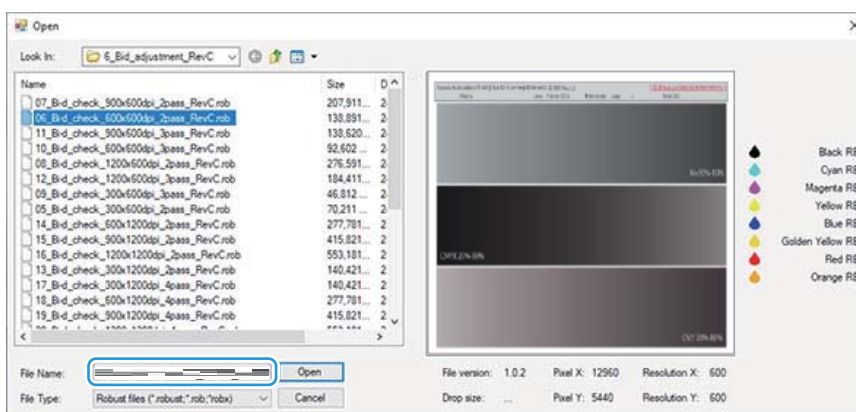

 Some types of ROB file creation software may automatically generate a design file for color patches at the same time as the ROB file. If there is a design file for color patches in the same folder as the ROB file and the design file for color patches has the same file name as the ROB file (ROBfilename_chips.rob), the design file for color patches is loaded at the same time the ROB file is loaded.

3 To load multiple job files, repeat steps 1 and 2.

Setting the Print Data

Check the job file, and configure the settings if necessary.

This section describes the settings to be configured for printing. For more information about job files, refer to the "Leonardo Reference Guide".



The resolution is set with ROB file creation software (EpsonEdgePrint Textile) when the job file is created, and therefore cannot be set here. To change the resolution, create the job file again.

1 Set the number of passes. Use the slider on one of the bars to select a value.

Vertical resolution of 600 dpi: Left bar

Vertical resolution of 1,200 dpi: Right bar

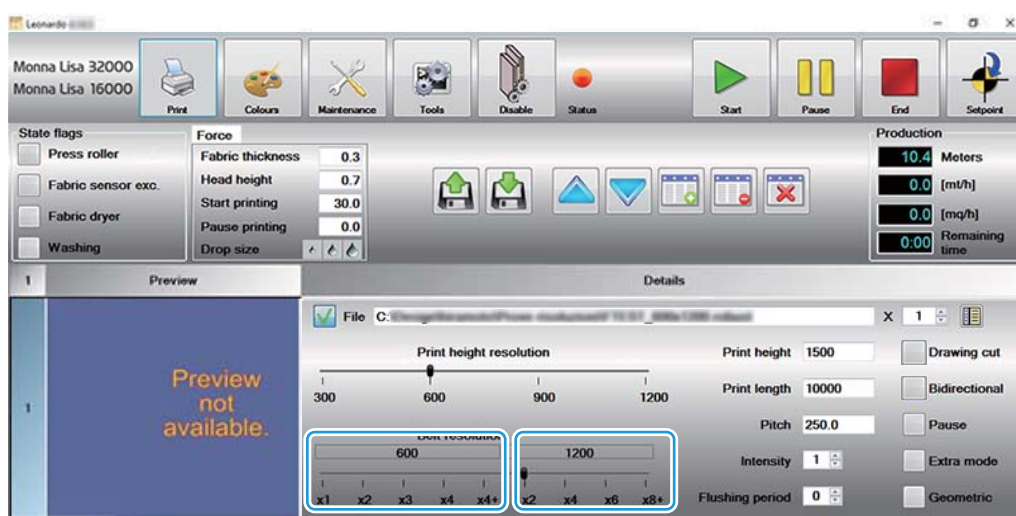

2 Specify the printing direction for the print heads. Select [Bidirectional] for bidirectional printing.



- 3** Extra mode uses twice the amount of ink as usual. Select [Extra mode] to print in this mode.



Selecting Extra mode causes the print speed to drop.

Printing

Checking the Status of the Fabric

Check the status of the fabric.

- The fabric must be pulled into the print surface and spread out flatly.
- There must not be any folds or protrusions and the fabric must not be lifted up.
- If there is a seam between pieces of fabric, take measures to make it flat so that it does not scrape against the print head.

Checking the Towel Roller

If the towel roller is installed, check that the towel roller is down.

Checking the Print Path

Check the print path.

- No foreign material in the print head operating area.
- There must not be any abnormalities in the fabric path or winding path.

Checking the Ink

Before printing, lift the ink cartridges in the ink rack by hand to check if they contain sufficient ink.

Configuring the Print Settings

Set the print length and the margin (right side) for when printing starts.



Item	Description
Start printing	Set the margin from the right edge. (mm)
Pause printing	Set the length from when printing starts until it stops. (m)

Check the length of the fabric to be printed on, and then enter a value at least 3 m shorter than the actual fabric length.

**WARNING**

For the following reasons, perform settings so that printing ends with 3 m or more of fabric left.

- If the ending edge of the fabric is not affixed to the core, the fabric can slip off the core, meaning it is not held by the brake or tension device and cannot properly adhere to the belt. If printing continues in that state, the fabric can become caught on the print head and damage the print head.
- If the ending edge of the fabric is affixed to the core, the belt is pulled by the piece at the end of the fabric, putting excessive strain on the belt motor. This could cause belt motor malfunctions.

**CAUTION**

We recommend always using the Pause printing option.

Using this option lets you set the length (meters) to be printed. When printing stops, the machine pauses and waits for the next command.



A test print should be at least 1 m, to check for banding due to misalignment of the print heads.

Printing

1 Click the [Start] icon.



2 If the "Enable belt cleaning" message is displayed, click [YES].

3 Starts printing. The printed fabric is fed to the belt on the machine front.



If there are any print quality problems, refer to ["Print Quality" on page 137](#).

Checking the Cleaning Unit

Confirm that water is provided to the cleaning unit and check the water level in the tank.

Printing Ends

After it finishes printing the set length, the printer stops in the pause status.

After the printer stops, the operator can remove the fabric from the core that finished printing, then handle any issues such as folds in the fabric edge by hand.

Stopping Printing

When printing of the job files that were set when printing started is complete, the machine stops automatically. To stop printing before printing is complete, click [End] in Leonardo.



Replace the Ink

Checking the Amount of Ink

Use the [Colours] menu in Leonardo to check the amount of ink in the ink system.

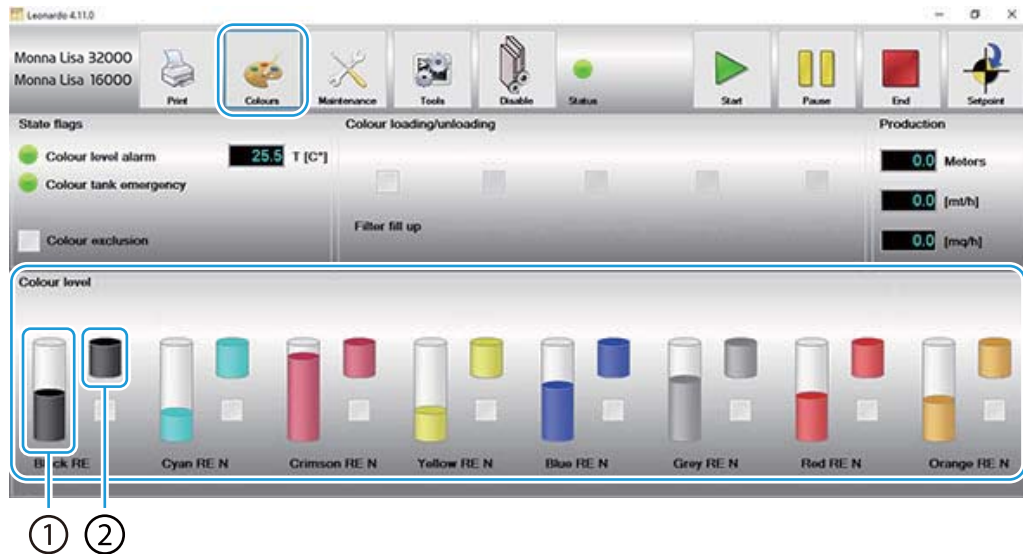

No.	Name	Description
1	Main tank	Allows you to check the approximate amount of ink remaining in the ink cartridge.
2	Sub-tank	Allows you to check the approximate amount of ink remaining in the sub-tank.

Replace the Ink (3L)

For 3L ink cartridge model.

The buzzer sounds when low ink is detected in this machine.

Use the following procedure to replace ink.

	<p>Replace the ink within one minute after low ink is detected. Continuing to print after ink low is detected without replacing ink will cause printing to stop when the sub-tank rack is empty.</p>
---	--

1 In the [Colours] menu in Leonardo, check the number of the ink cartridge in which the ink is low.

Example: "Colour tank 4 empty" (The number is the ink cartridge number)





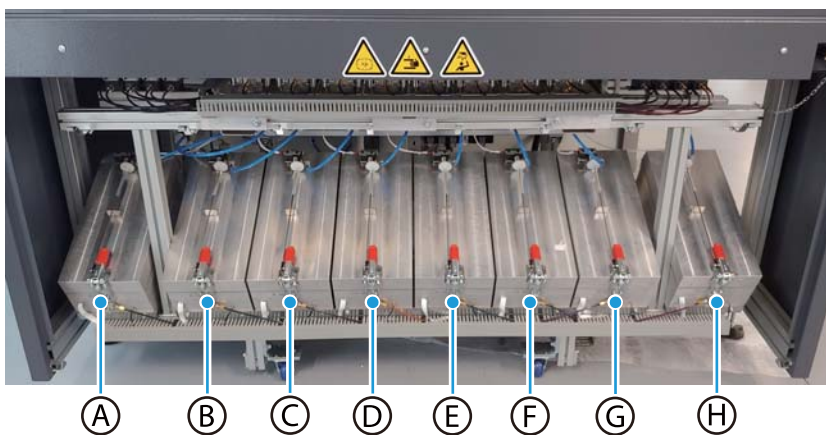

Ink cartridge numbers

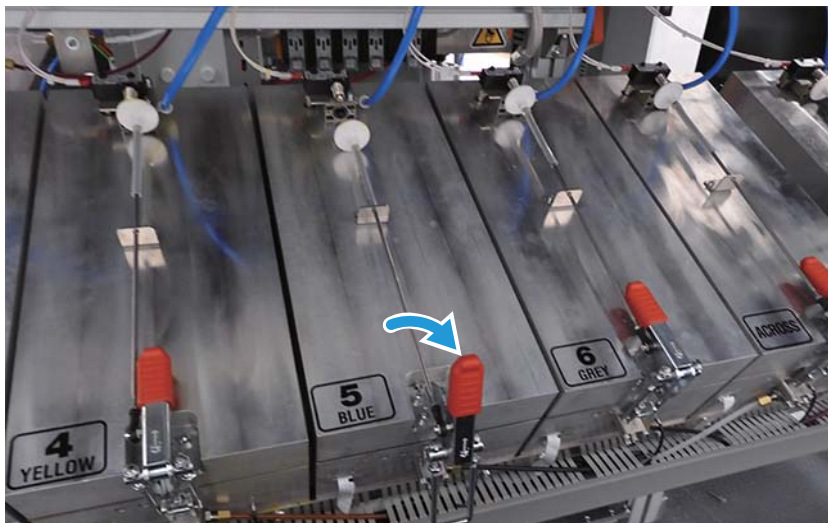

- 2 Pull the tank opening/closing handle on the ink tank that contains the ink cartridge to be replaced.



- 3 Lift the ink tank cover carefully (1) and hook the tank opening/closing handle onto the cover support hook (2).

 CAUTION	
	<p>Make sure that the tank opening/closing handle is hooked on the cover support. If the ink tank cover closes, your hand could be caught in the machine and get injured.</p>
	<p>Open the ink tank cover gradually and with care. The ink tank interior is under pressure. When the cover is opened, the released pressure could injure your hand.</p>
	<p>Be careful not to hit your head on the upper area of the ink rack. Failure to do so could lead to injury.</p>

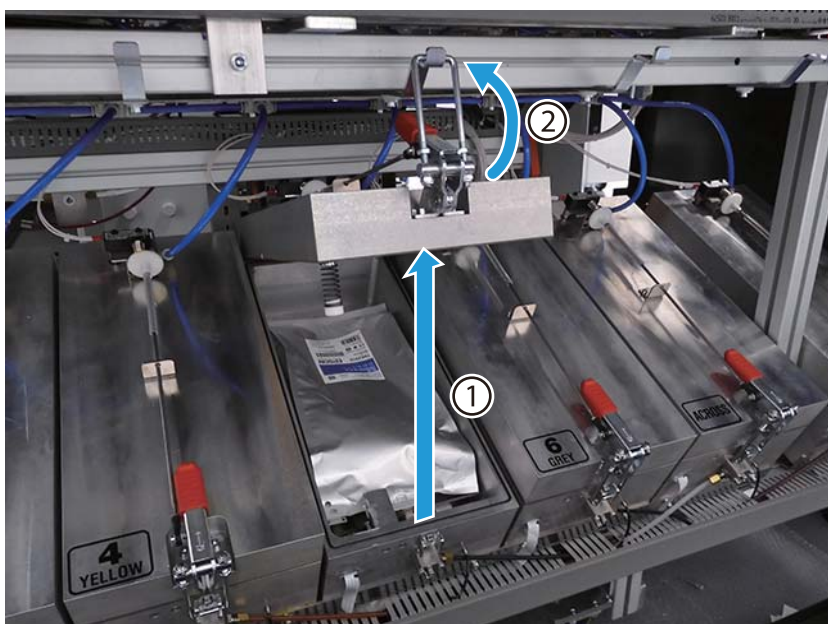

- 4** While pushing the cartridge carriage upward (1), turn the lever to the left (2). Then, the ink cartridge supply port is disconnected from the ink tank needle and the cartridge carriage is secured.



- 5** Push up the IC chip on the ink cartridge to remove it from the reader and remove the used ink cartridge.



- 6** Shake a new ink cartridge to stir the ink.

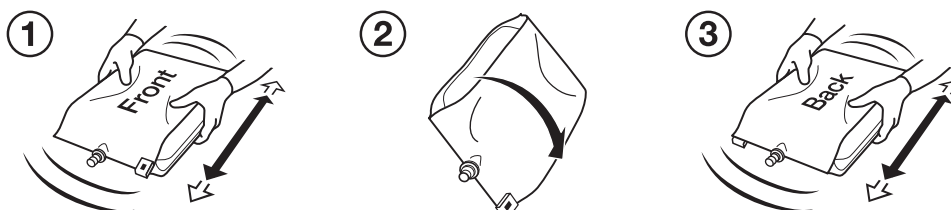

- 7 Set the new ink cartridge on the cartridge carriage with the its label facing upward.
- 8 Set the depressed part of the ink cartridge supply port into the supply port securing section (cutout). Set the port in the correct position as shown in the figure below.

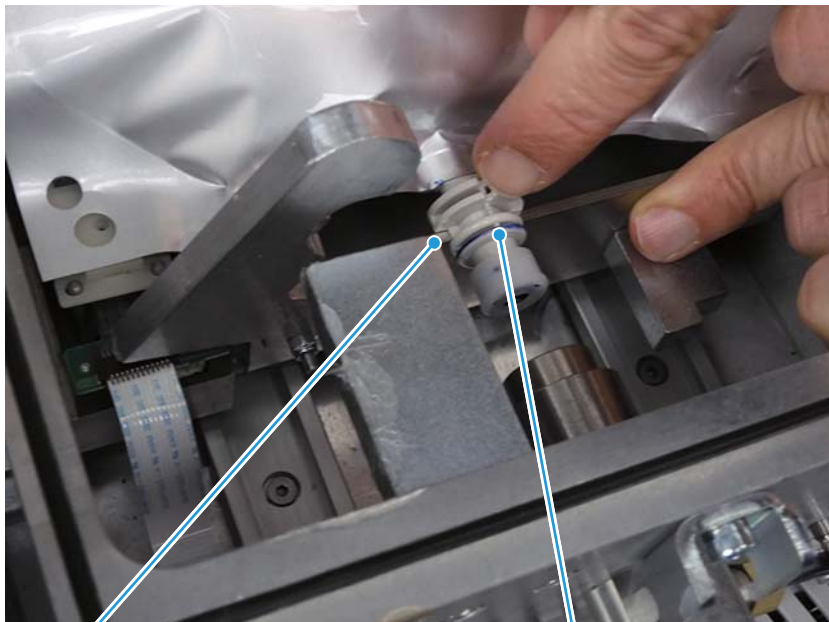

Supply port securing section

Ink cartridge supply port

OK

Pattern A

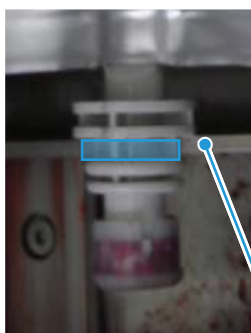

Cutout on supply port securing section



Pattern B



Cutout on supply port securing section



Pattern C



Depressed part of ink cartridge supply port



CAUTION

- Pattern B may cause ink leaks due to the ink cartridge supply port being insufficiently inserted.
- Pattern C may damage the ink cartridge supply port or needle.

- 9** While pressing on the cartridge carriage with your right hand, turn the lever to the right and set the lever above the ink cartridge supply port.



- 10** Move the cartridge carriage slowly toward you. The needle is inserted into the ink cartridge supply port and the ink cartridge is set in place.

11 Connect the IC chip on the ink cartridge to the reader. Attach the holes on the IC chip onto the pins on the reader.

	<p>If the IC chip is not connected correctly, the ink cartridge is not recognized on the machine.</p>
---	---

OK

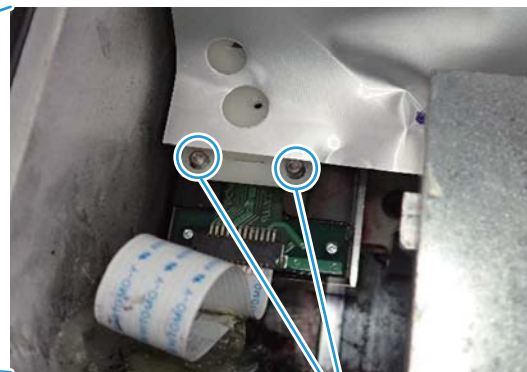
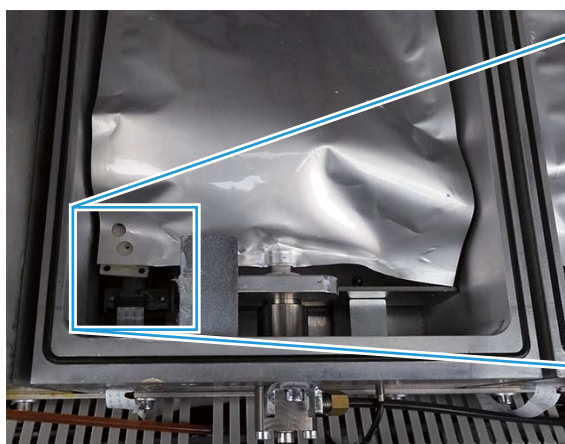

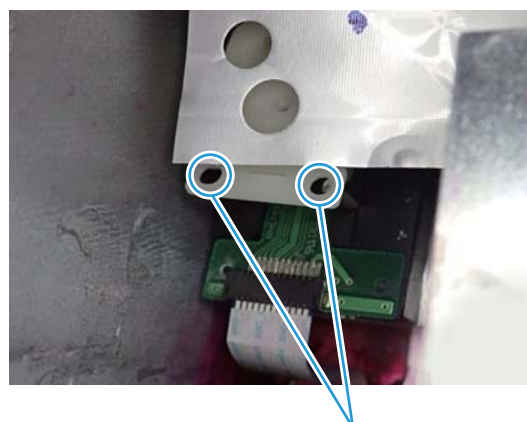

The pins are inserted in the holes on the IC chip.



The pins are not inserted in the holes on the IC chip.

- 12** Unhook the tank opening/closing handle from the cover support hook (1), and close the ink tank cover (2).

 CAUTION	
	If the ink tank cover closes, your hand could be caught in the machine and get injured. Make sure that the tank opening/closing handle is hooked on the cover support hook.
	Your head may hit the upper area of the ink rack during replacement work. Pay careful attention while working.

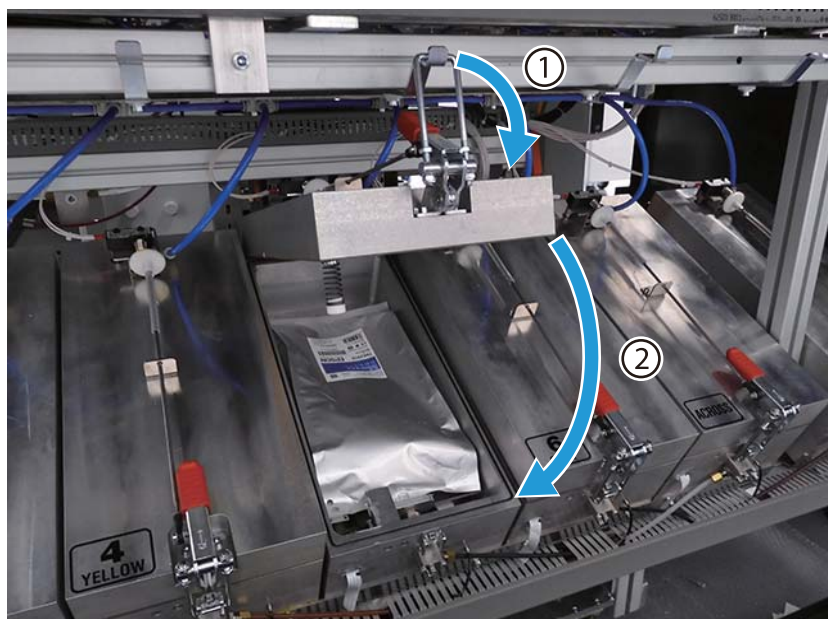

- 13** Push the tank opening/closing handle downward and lock the ink tank cover.

Use the [Colours] menu in Leonardo to check that the ink status has changed.

Replace the Ink (10L)

For 10L ink cartridge model.

The buzzer sounds when low ink is detected in this machine.

Use the following procedure to replace ink.



Replace the ink within five minutes after low ink is detected.

Continuing to print after ink low is detected without replacing ink will cause printing to stop when the sub-tank rack is empty.

- 1 In the [Colours] menu in Leonardo, check the number of the ink cartridge in which the ink is low.

Example: "Colour tank 4 empty" (The number in quotes is the ink cartridge number)



Ink cartridge numbers

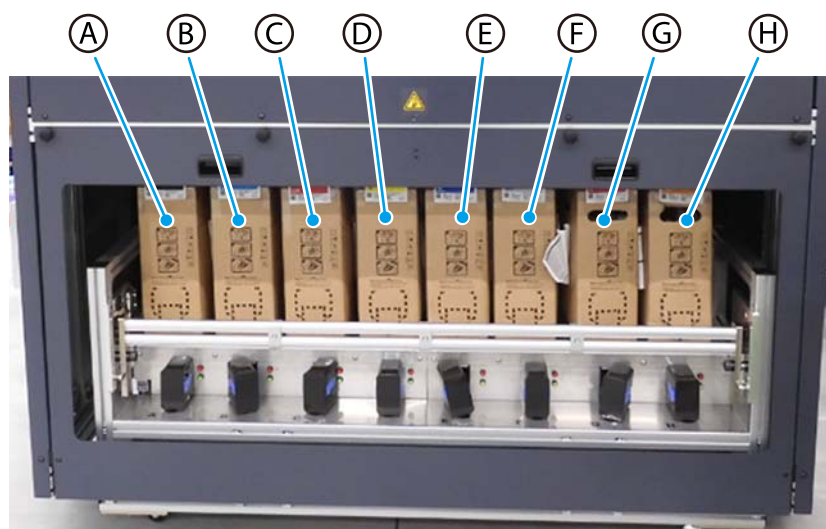

- 2 Double-click the ● icon for "Colour level alarm". The buzzer stops, and the ● icon changes from yellow to green.

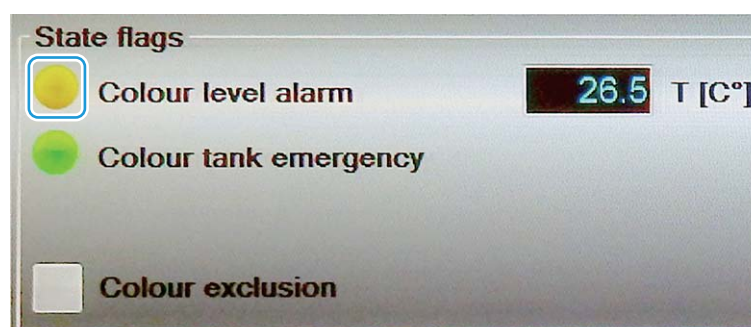

3 Check on the ink rack if the cartridge check lamp of the corresponding ink cartridge lights up in red.

4 Prepare a new ink cartridge, and stir the ink.

- (1.) Place the ink cartridge with the ink supply port facing the side, and slide the ink cartridge back and forth longitudinally within the range of approximately 10 cm for ten times. Move the ink cartridge at a rate of one back-and-forth cycle per second.
- (2.) Turn over cartridge and slide it back and forth 10 times in the same way.

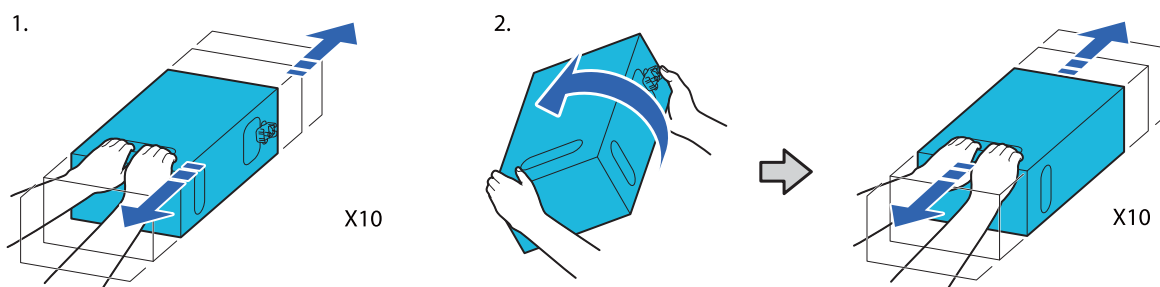

5 Place the ink cartridge as shown in the following image.

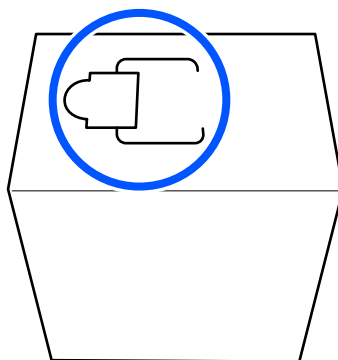

6 Use your hands to cut along the dashed lines of the slot to remove the top portion.



CAUTION

Do not use a cutter to cut along the dashed lines. Failure to observe this precaution could damage the internal parts and cause ink to leak.

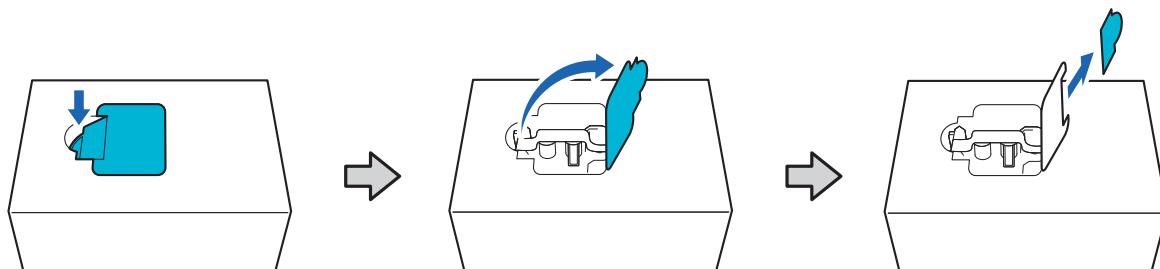

- 7** Take out the ink supply port and fix it as shown in the illustration.

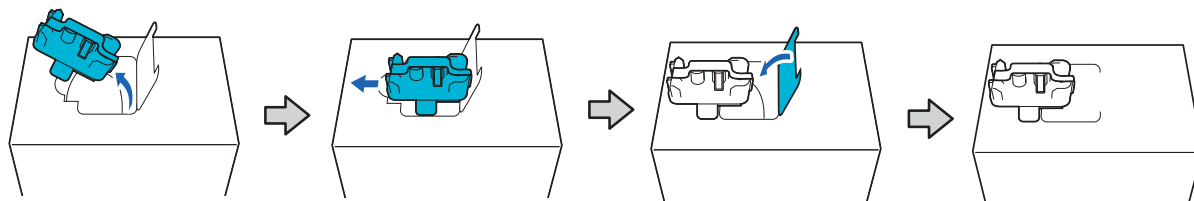

- 8** Peel the tape (yellow) from the surface of ink supply port.

**CAUTION**

Do not touch the IC chip on the ink cartridge.

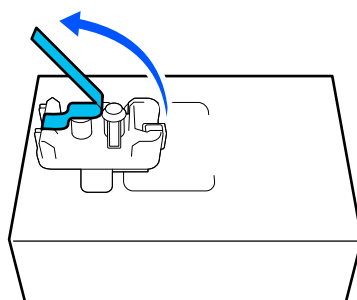

- 9** Pull the ink rack front bar towards you and down.

- 10** Remove the ink cartridge to be replaced from the ink rack. Grab the blue lever on both sides of the connector, and then pull it out toward you.

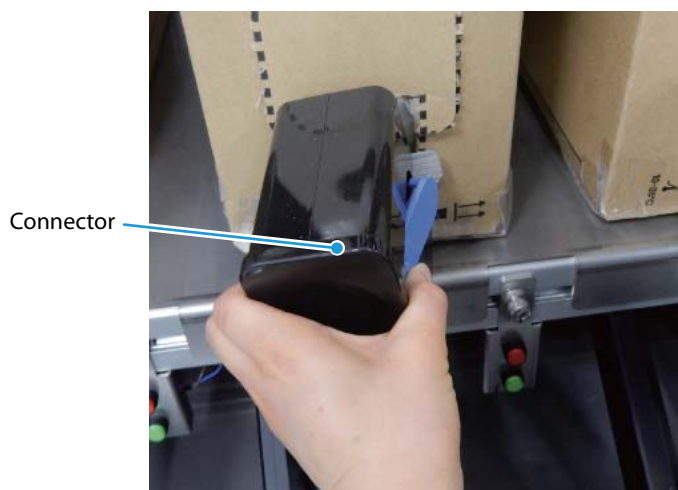

- 11** Lower the ink cartridge to be replaced from the ink rack.

- 12** Set the new ink cartridge in the ink rack.

- 13** Insert the connector of the ink rack into the ink supply port of the ink cartridge. Push the needle of the connector into the ink supply port of the ink cartridge. Insert it carefully and securely as shown in the following image.



- 14** Raise the ink rack front bar up.

This completes ink replacement. When the sub-tank is filled with ink, the green LED on the ink rack illuminates.



Changing User Permissions

There are two types of user permissions: "L user permissions" and "H user permissions".

For more information about user permissions, refer to ["User Permissions" on page 4](#).

The procedure for changing permissions is described below.

- 1 Click "Show Hidden Icons" in the Windows taskbar. Click [HookMe].



- 2 The [Login] screen is displayed. Enter the user-level password, and click [OK].

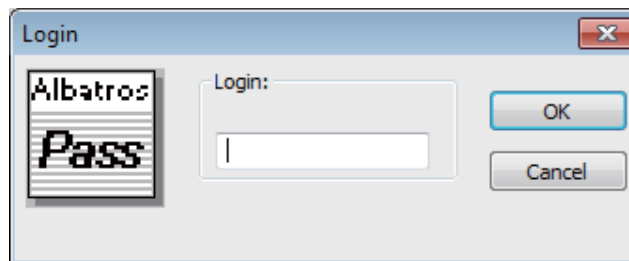

The passwords for the respective user modes are listed below.

L user: L

H user: H

Checking the Belt Cleaning Unit Operation

Colour exclusion mode is used for performing printing operations such print head operation and belt feeding without the use of ink.

You can check operation during Colour exclusion mode if you want to check operation of the belt cleaning unit without printing on fabric.

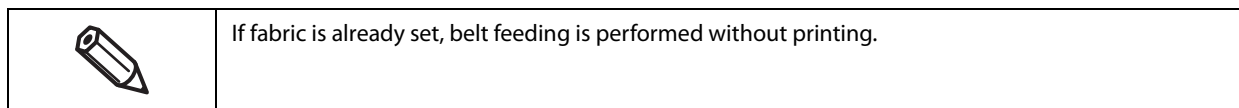

Follow these procedures to use this mode.

- 1 In the [Colours] menu, select [Colours exclusion].



- 2 Click the [Start] icon.

Workflow When Turning Off the Power

This section describes the procedure for turning off the power.

1. Inserting the Stopper Pin of the Pressure Roller ([Page 122](#))
2. Lifting Up the Towel Roller ([Page 123](#))
3. Cleaning ([Page 125](#))
4. Pushing an Emergency Stop Button for an Emergency Stop ([Page 125](#))
5. Exiting Leonardo ([Page 125](#))
6. Turning Off the Control PC ([Page 125](#))
7. Turning Off the Main Power Switch ([Page 126](#))
8. Closing the Water Supply Valve ([Page 126](#))
9. Exhausting of Compressed Air ([Page 127](#))

Inserting the Stopper Pin of the Pressure Roller

**CAUTION**

Be sure to always insert the pins on the left and right when work is completed. Leaving the hanging low may deform the belt.

- 1 Open the rear cover.
- 2 Turn the pressure roller switch to the left to lift up the pressure roller.
- 3 Insert the right-side stopper pin into the pressure roller.

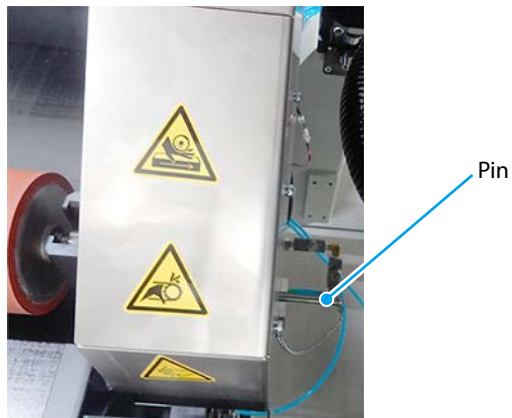

- 4 Insert the left-side pin into the pressure roller.

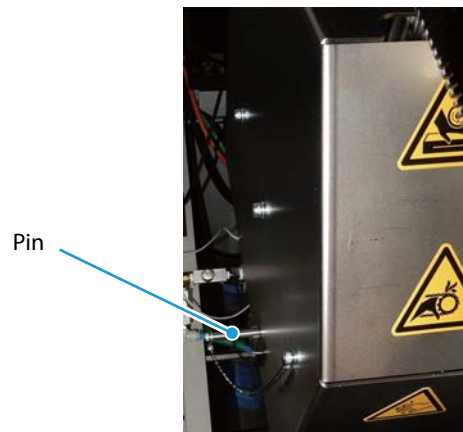

- 5 Close the rear cover.

Lifting Up the Towel Roller

Lift up the towel roller away from the belt.

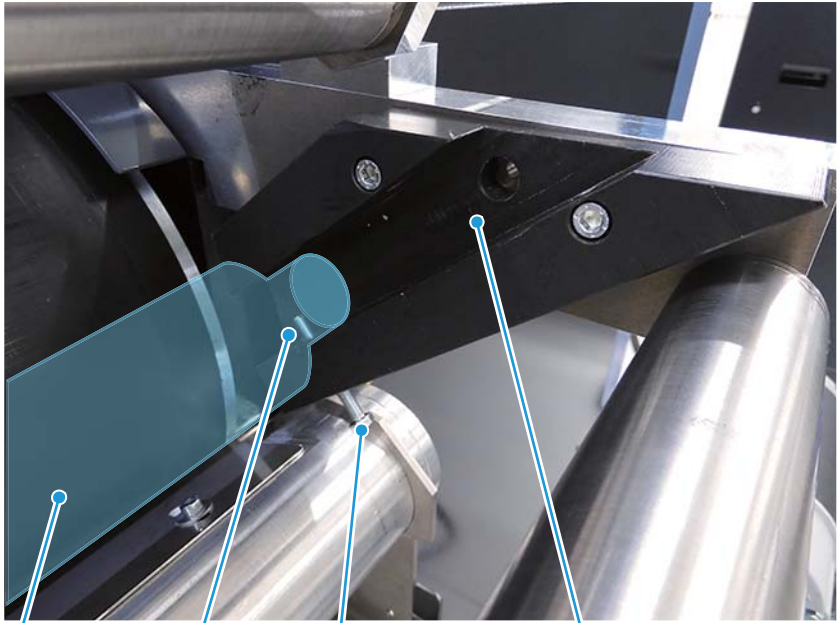
	<p>To lift up the towel roller, lift the towel roller first and tighten the supporting screw with the screw sticking out into the groove. Then, lower the towel roller spindle onto the screw.</p> <p>Towel roller in upper position</p>  <p>Towel roller Supporting screw Towel roller groove</p> <p>Supporting screw sticking out into the groove supports the towel roller spindle</p>
---	--

	<p>If the towel roller is kept in contact with the belt for a long time, glue on the belt may adhere to the towel roller. Keep the towel roller in the lifted position while the machine is not in printing operation.</p>
---	--

- 1** While lifting up the right side of the towel roller toward you, tighten the supporting screw (right) by hand keeping the screw sticking out into the groove.

**CAUTION**

When the supporting screw is loosened, the towel roller automatically lowers under its own weight. Be careful not to get your fingers caught between the towel roller and the belt.

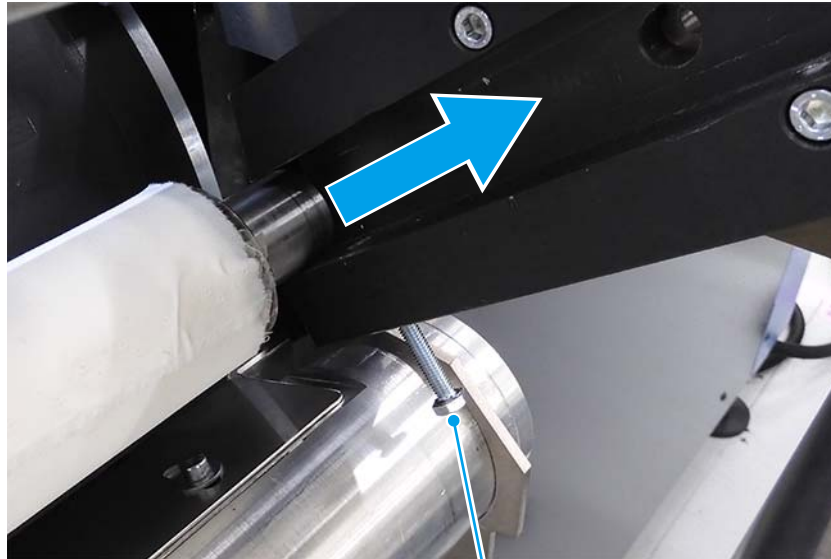

Supporting screw

- 2** Lower the towel roller gradually onto the supporting screw.

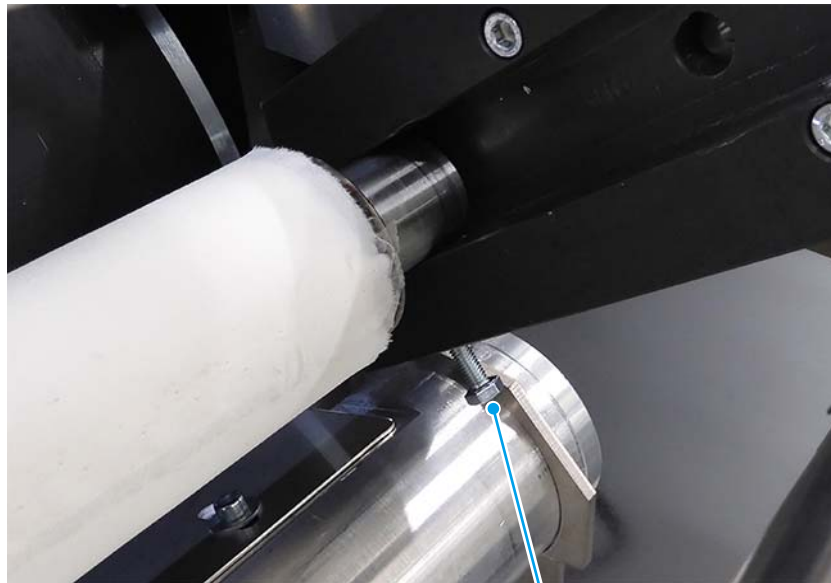

Supporting screw

- 3** Repeat procedures 1 and 2 on the left side of the towel roller.

Cleaning

Wipers and Caps

Refer to the "Maintenance Guide".

Flushing Plate

Refer to the "Maintenance Guide".

Belt (When Using Pigment Ink)

When pigment ink adheres to the belt, an ink film is formed. To prevent ink films, clean the belt referring to the Maintenance Guide.

Push an Emergency Stop Button for an Emergency Stop

Push the emergency stop button to put the machine in emergency stop status, so that the print heads and motor do not operate suddenly when the power is turned on.

There are five emergency stop buttons around the machine. Firmly press one of these emergency stop buttons.

Exiting Leonardo

Exit Leonardo.

Turning Off the Control PC

Shut down the control PC.

Turn off the Main Power

Turn off the power. Turn the main power switch on the main electric box to 0 (OFF).

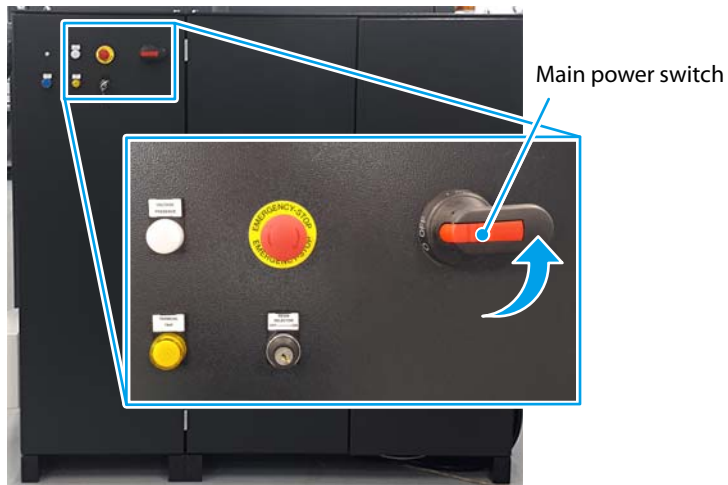

Closing the Water Supply Valve

Close the water supply valve at the bottom of the front of the machine.

Using a flat-head screwdriver, tighten the water supply valve.



Exhausting of Compressed Air

Exhaust the compressed air that has been supplied to this machine.

Turn the red valve of the air pressure supply regulator clockwise to change the indicator for the valve from "SUP" to "EXH".

Make sure the air is exhausted and the meter goes to zero.



When Not Using the Printer

This chapter is applicable to machines with sponge rollers.

To keep the printer functioning properly, perform the following maintenance when the printer is not in use. Maintenance methods vary depending on the period of time the printer is not in use.

- If the printer will not be used for two days to a week: Keep the sponge roller in antimicrobial storage.
- If the printer will not be used for more than one week: Keep the sponge roller in dry storage.



CAUTION

If the sponge roller is not stored properly when the printer is not in use, the sponge could become moldy or deformed.

When the Printer will Not Be Used for Two Days to a Week

If the printer will not be used for two days to a week, remove the sponge roller from the machine and store it in the sponge roller tank for antimicrobial storage.

Before starting work, be sure to prepare the following items.

- Personal Protective Equipment: Eye protection, protective gloves and clothing
- Sponge roller tank
- Two belt cleaning unit wheels
- Hex key (width: 6 mm)
- Bucket for antimicrobial solution. Commercially available
- Antimicrobial agents: Commercial products containing Benzisothiazol (CAS RN: 2634-33-5)



CAUTION

- Do not use antimicrobial agents that contain quaternary ammonium salts. Foreign matter produced by the reaction between the antimicrobial agent and ink might adhere to the belt, making it impossible to clean the belt.
- Due to the weight of the belt cleaning unit, it should be pulled out and returned to its original position by the number of workers indicated below.
ML-16000-340: 3 persons
ML-32000-240/ ML-32000-180/ ML-16000-180: 2 persons
- Due to the weight of the sponge roller, it should be installed and removed by two workers.

Before starting work, turn off the machine.

- 1 Turn the left drain valve in the direction of the arrow to close it.

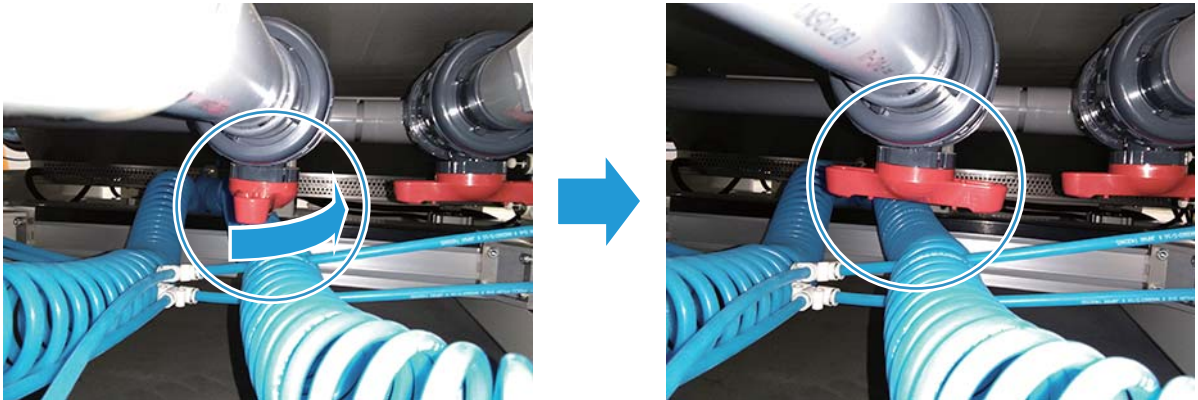

- 2 Pull the belt cleaning unit toward you until the carriage rail hits the stopper nearest from you.



- 3 Remove the sponge roller and then place it in the sponge roller tank.

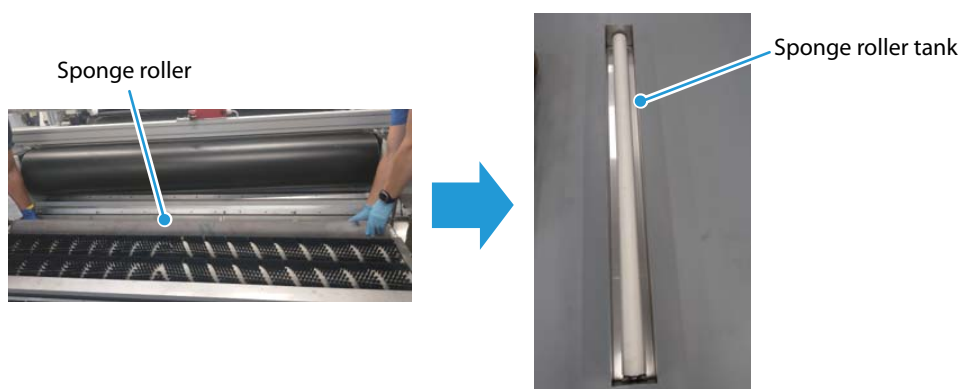

- 4 Prepare a water solution containing 0.01~0.02% Benzisothiazol (CAS RN: 2634-33-5) concentration in a bucket to match the capacity of the sponge roller tank.

The capacity of the sponge roller tank for each model is indicated below.

ML-16000-340: 45 - 55 L

ML-32000-240: 35 - 40 L

ML-32000-180/ ML-16000-180: 25 - 30 L

- 5** Fill the sponge roller tank with an antimicrobial solution, and store the sponge roller so that it is completely submerged. If the sponge roller absorbs the antimicrobial solution and the water level drops, add tap water.

**CAUTION**

Be careful not to knock over the sponge roller tank.

This completes the work.

When the Printer will Not Be Used for More than One Week

If the printer will not be used for more than one week, remove the sponge roller from the machine and store it in the sponge roller tank for dry storage.

Before starting work, be sure to prepare the following items.

- Personal Protective Equipment: Eye protection, protective gloves and clothing
- Sponge roller tank
- Two belt cleaning unit wheels
- Hex key (width: 6 mm)



CAUTION

- Due to the weight of the belt cleaning unit, it should be pulled out and returned to its original position by the number of workers indicated below.
ML-16000-340: 3 persons
ML-32000-240/ ML-32000-180/ ML-16000-180: 2 persons
- Due to the weight of the sponge roller, it should be installed and removed by two workers.

Before starting work, turn off the machine.

- 1 Pull out the belt cleaning unit.**
Perform steps 1 through 5 of "When the Printer will Not Be Used for Two Days to a Week". ([page 128](#))
- 2 Remove the sponge roller and then place it in the sponge roller tank for dry storage.**



Sponge roller



This completes the work.

When Resuming Printing

- 1 If the sponge roller was placed in dry storage, fill the sponge roller tank with tap water so that the sponge roller is completely submerged, and keep it submerged for four hours.
- 2 Remove the sponge roller from the sponge roller tank and install it on the belt cleaning unit.
- 3 Return the belt cleaning unit to the carriage rail.
- 4 Return the belt cleaning unit to the original position.

	<p>Insert the belt cleaning unit straight in its original position. If it is inserted at an angle, the belt cleaning unit position sensor in the left rear will be unable to detect it, and therefore the emergency stop status may not be released.</p> <p style="text-align: center;">Belt cleaning unit position sensor</p> 
---	--

- 5 Turn the left drain valve in the direction of the arrow to open it.

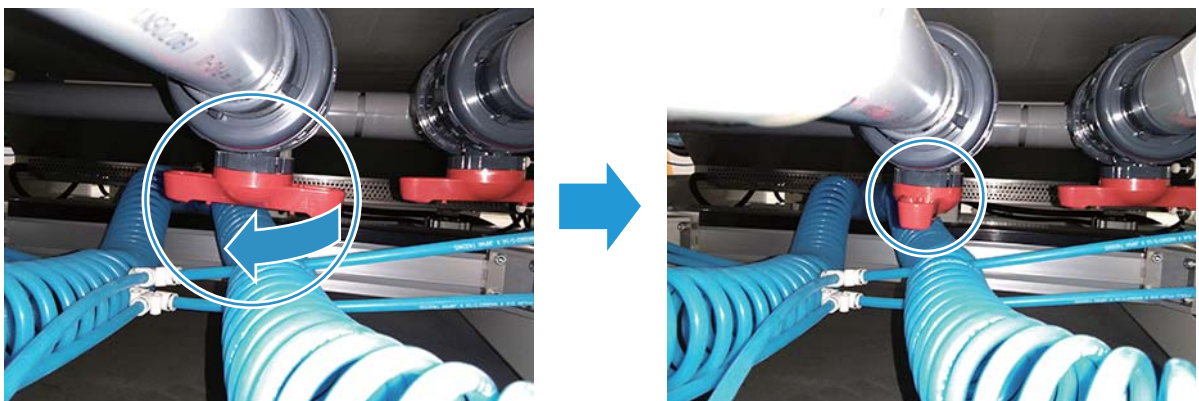

This completes the work.

Troubleshooting

This section describes actions to take when trouble occurs.

Error Messages

This section describes the causes for error messages and the actions that should be taken.

If the trouble is not resolved even after taking these actions, contact the distributor where the machine was purchased for assistance.

Error Messages	Cause	Action
Bag not recognized Do you want to continue?	The ink cartridge is not recognized.	Disconnect the ink cartridge and then connect it again.
Colour doesn't match previous. Do you want to continue?	The color of the ink cartridge has changed.	Check if the ink cartridge is the wrong color.
Bag not inserted	The ink cartridge is not connected correctly.	Check if the connector is connected to the ink supply port on the ink cartridge correctly. Disconnect the ink cartridge and then connect it again.
Colour tank empty (Audible and light alarm)	Low ink was detected.	Replace the ink cartridge. If the ink cartridge is not replaced, printing will continue until the ink in the reserve tank in the ink system runs out, and then the machine will stop in "Pause" status. After the ink cartridge is replaced, press [Start] icon to restart printing.
Machine emergency (Light alarm)	An emergency stop button has been pressed. A fault has been detected.	Check the reason why the emergency stop button was pressed. Inspect the machine to see if a fault has occurred. Remove the cause of the fault. Turn off the power to the machine, turn off the system, reset all errors that have occurred, and then restart the system.
Guard emergency	A front covers or rear cover is open.	Close the front covers or rear cover.
No air	The air pressure is not sufficient. Air is not being supplied.	Check the air pressure. Check the air supply system in the factory.
Run machine set-point	Setpoint has not been executed. Setpoint has been reset due to a fault.	Execute Setpoint. If Setpoint was reset due to a fault, check the cause of the fault and reset it before executing Setpoint.

Error Messages	Cause	Action
Piece fault.	<p>The fabric to be printed on is not affixed to the belt.</p> <p>There is an abnormality or fault on the surface of the fabric.</p>	<p>Check the fabric, and remove any folds or bulges.</p> <p>Remove the fabric and install it again.</p>
Check piece fault excluded	The foreign material detection sensor is disabled.	<p>Enable the foreign material detection sensor.</p> <p>It is dangerous to print with the foreign material detection sensor disabled. If an abnormality occurs in the fabric, or if the fabric is not affixed to the belt, the print heads could be damaged.</p>
Printing suspended	Printing was paused by request.	Remove the cause for pausing the printer, and then click [Start] icon to restart printing.
Head height incorrect	The print head height is incorrect.	Check the setting value.
Piece too tall	The fabric height is incorrect.	Check the setting value.
Initial design position too small	The print data setting is incorrect.	Increase the value for start printing.
Head not in safe position.	The print heads are not in the correct position.	Contact qualified service personnel for assistance.
CARRIAGE. carriage linear motor: Servoerror	The position of the print heads is not recognized due to a mechanical impediment.	<p>Press an Emergency stop button.</p> <p>Turn off the power to the machine.</p> <p>Remove the cause of the fault. Turn on the power to the machine.</p>
CARRIAGE. carriage linear motor: encoder connection incorrect	The print heads were moved by hand.	
CARRIAGE. carriage linear motor: movement not completed	The print heads cannot move to the specified position due to a mechanical impediment.	
BELT. belt drive motor: Servoerror	The position of the belt is not recognized due to a mechanical impediment.	
BELT. belt drive motor: encoder connection incorrect	The belt was moved by hand.	
BELT. belt drive motor: movement not completed	The belt cannot move to the specified position due to a mechanical impediment.	
"xx-x" albre receiver disconnected	One or more devices have been disconnected from the internal system network.	<p>Press an Emergency stop button.</p> <p>Turn off the power to the machine.</p> <p>Check the connection of the network cable.</p> <p>Turn on the power to the machine.</p>
"xx" albre receiver disconnected		
"x" albstep receiver disconnected		

Error Messages	Cause	Action
"xx-x" albre receiver: +24cc power supply error	An error has occurred in a +24 V power supply device on the machine.	Press an Emergency stop button. Turn off the power to the machine. Check the status of the device. Turn on the power to the machine.
"x" albstep receiver: +24cc power supply error		
File opening error	There is an error in the "ROBUST" file in the CAD system.	Delete the file. Create the file again in the CAD system.
File reading error		
Incongruent data in source file		
Quantity of data incorrect in file header		
Too many colour row values specified		
Design file version old		
Design file version not supported		
The height pixels exceed the print capacity		
Height resolution differs from that in the file		
Length resolution differs from that in the file		
Drop type in file incorrect		
Height increments don't match those in the file		
Length increments don't match those in the file		
Out of memory	A problem has occurred in the system memory.	Check if the OS settings on the system PC have been changed. Restart the machine.
There isn't enough memory to run the next band.		
File not found	The file to be printed was not found in the specified directory.	Specify the correct file name and directory.
Dongle error	The system does not recognize the dongle.	Contact qualified service personnel for assistance.
Invalid dongle		
Colours different from those in the machine	The printed color does not match either the file to be printed or the specified color.	If there is no problem with the color to be printed, continue printing. Check the file to be printed.
Colours in design file swapped		

Error Messages	Cause	Action
Print start error	An error or fault has occurred in the control system during system initialization or printing.	Restart the machine.
First pixel error		
Pixel count error		
TIMEMAC error		
REQ error		
Interruption due to TIMEMAC error		
Generic error	An unidentified error has occurred.	Restart the machine.
"Foreign material sensor" detected some foreign materials or a fabric error	The foreign material detection sensor detected foreign material on the belt or wrinkles or folds in the fabric.	Check if there is any foreign material on the belt and if the fabric is wrinkled or folded.
"Head stroke sensor" detected some foreign materials or a fabric error	The head stroke sensor detected foreign material on the belt or wrinkles or folds in the fabric.	Check if there is any foreign material on the belt and if the fabric is wrinkled or folded.
HEAD4 "\$x" DRV "\$x" temperature > "\$x"°	The temperature of the print head drive substrate cannot be lowered.	Clean or replace the cooling fan filters. For more information about cleaning and replacement, refer to the Maintenance Guide.
Rear Chuck System sensor maintenance required	The belt control unit does not operate properly.	Make sure there is no ink, glue, tape, etc. on the right or left edges of the belt (within 25 mm of the edge of the belt). If there is any ink, glue, tape, etc. stuck to the edges of the belt, wipe the edges clean with a cloth soaked in an appropriate amount of ethanol. If the same error occurs again after cleaning, contact qualified service personnel.
Rear Chuck System sensor fault		
Front Chuck System sensor maintenance required		
Front Chuck System sensor fault		

Print Quality

Condition	Cause	Action
Poor print quality	Faulty discharge of print head	Increase the number of printing passes. (Refer to "Loading the Print Data" on page 100) Perform a nozzle check when changing jobs. Check that discharge is normal (normal print quality) before printing.
Mixed ink colors	Ink mixing is occurring in the print head.	Perform manual flushing for the print head. (Refer to "Manual flushing" on page 137)

Manual flushing

Perform manual flushing on the print head to resolve ink color mixing.

1 Click [Maintenance].

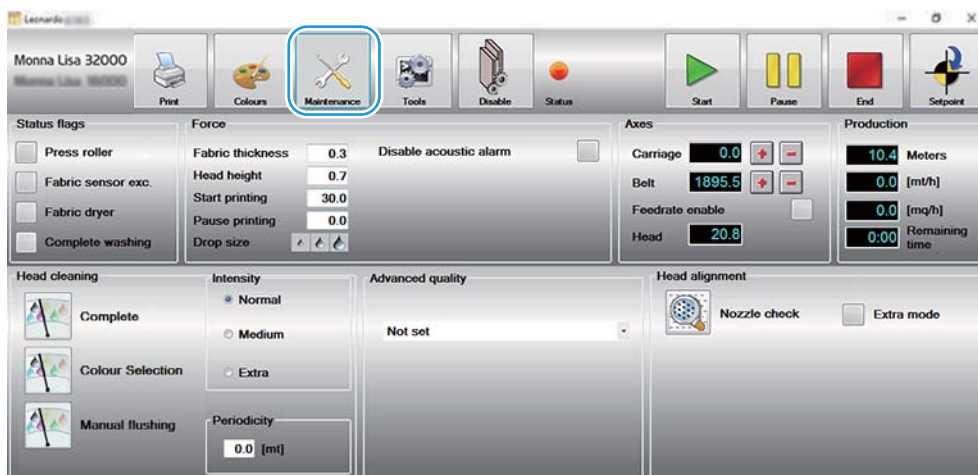

2 Click [Manual flushing].



- 3 On the [Color Selection] screen, select the print head for manual flushing. Multiple print heads can be selected.

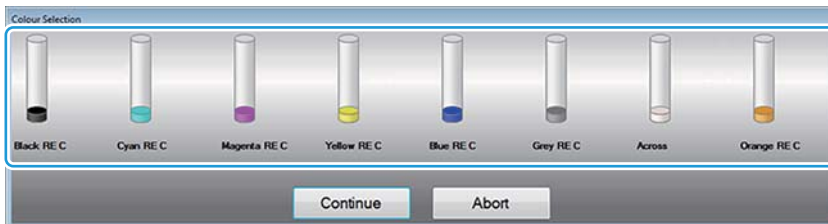

The selected print head changes its display as shown below.

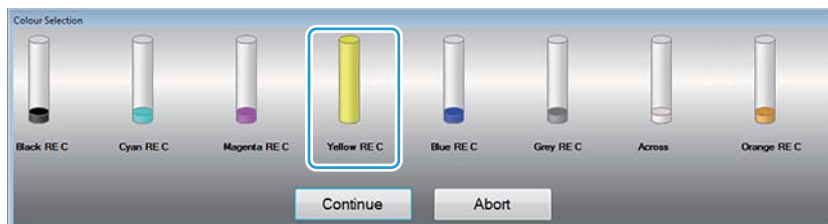

- 4 Click [Continue].
The print head moves over the flushing plate and starts manual flushing. When manual flushing is completed, the print head returns to its original position.
- 5 Perform a nozzle check to see if there is any ink color mixing.
For more information, refer to ["Nozzle Check" on page 67](#).
If the nozzle check pattern has mixed colors, perform manual flushing again.

Print Head Failure

If a print head failure occurs, promptly make a request for repairs to be performed.
If a print head failure occurs on this machine, you can configure the settings so that only that specific head column is not printed. The other print heads will cover for the head that does not print. This will cause the print speed to drop, but production can continue until the head is repaired.

	<p>For more information about how to use this function, contact qualified service personnel.</p>

- 1 Use nozzle check and other functions to identify the print head that has failed.
- 2 Click "Disable" icon in Leonardo.

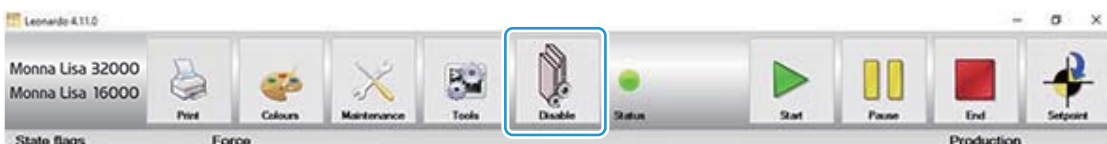

3 Select the check box for the column or row of the print head that has failed, and an "X" will appear at that position.

For ML-16000-180 and ML-16000-340.

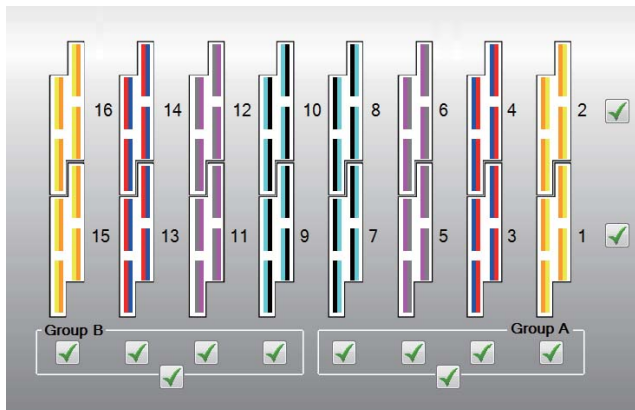

 We do not recommend unselecting the check boxes for [Group A/Group B] along the bottom of this screen; doing so might adversely affect image quality.

For ML-32000-180 and ML-32000-240
In this example, head 2L-24 has failed.

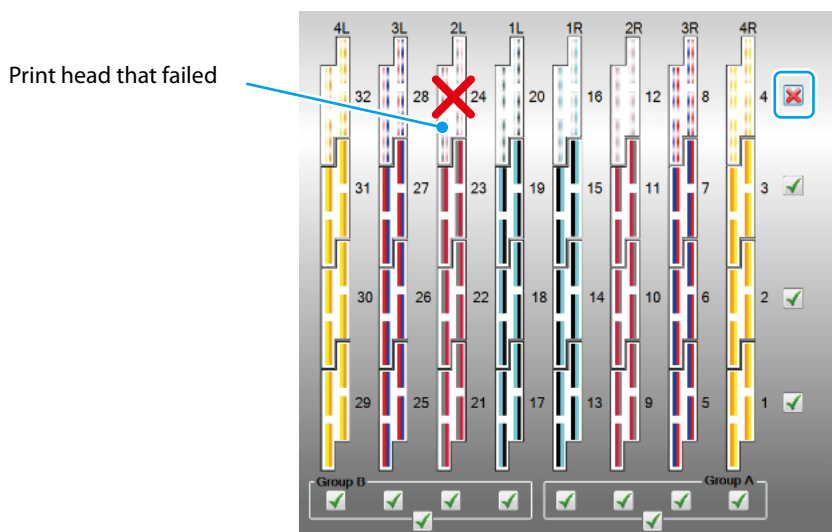

In this case, column 4 will not be used when printing.

 An X cannot be set for only column 2 or only column 3. Use this setting for the columns on the outer edges.
We do not recommend unselecting the check boxes for [Group A/Group B] along the bottom of this screen; doing so might adversely affect image quality.