

ML-64000-180

User's Manual

Safety and Accident Prevention

Product Overview

Name and Function of Each Part

Basic Printing Flow

Maintenance

Problem Solver

Specifications

Appendix



Original instructions

Cautions

- No part of this document may be reproduced, stored in a retrieval system, or transmitted in any form or by any means, electronic, mechanical, photocopying, recording, or otherwise, without the prior written permission of Seiko Epson Corporation.
- The contents of this document are subject to change without notice.
- While every precaution has been taken in the preparation of this document, Seiko Epson Corporation assumes no responsibility for errors or omissions.
- Neither is any liability assumed for damages resulting from the use of the information contained herein.
- Neither Seiko Epson Corporation nor its affiliates shall be liable to the purchaser of this product or third parties for damages, losses, costs, or expenses incurred by the purchaser or third parties as a result of: accident, misuse, or abuse of this product or unauthorized modifications, repairs, or alterations to this product, or (excluding the U.S.) failure to strictly comply with Seiko Epson Corporation's operating and maintenance instructions.
- Seiko Epson Corporation shall not be liable against any damages or problems arising from the use of any options or any consumable products other than those designated as Original EPSON Products or EPSON Approved Products by Seiko Epson Corporation.

Trademarks

Microsoft, Windows are trademarks of the Microsoft group of companies.

All other product names and company names are the trademarks or registered trademarks of their respective owners.

©Seiko Epson Corporation 2019–2025

Contents

■ Contents.....	3
-----------------	---

Safety and Accident Prevention..... 7

■ Before Use.....	7
-------------------	---

Meaning of Symbols	7
--------------------------	---

Warning Labels	9
----------------------	---

■ Safety Information	12
----------------------------	----

General Precautions	12
---------------------------	----

Handling Precautions	13
----------------------------	----

Notes When Not Using the Printer.....	16
---------------------------------------	----

Regular Replacement Parts for Maintaining Safety	16
--	----

Cautionary Information Regarding Consumables (Ink, Cleaning Liquid, Maintenance Liquid) and Waste Ink	17
--	----

Precautions Regarding the Handling of Ink Cartridges.....	19
---	----

■ Emergency Stop and Pause.....	20
---------------------------------	----

Emergency Stop	20
----------------------	----

Pause.....	20
------------	----

Product Overview.....21

■ Product Overview	21
--------------------------	----

Name and Function of Each Part.....23

Front.....	23
------------	----

Front Section Interior.....	25
-----------------------------	----

Sides.....	26
------------	----

Side Interior	27
---------------------	----

Rear	28
------------	----

Rear Interior.....	31
--------------------	----

Ink Rack.....	32
---------------	----

Belt Cleaning Unit	34
--------------------------	----

Main Electric Box	35
-------------------------	----

Front Panel.....	36
------------------	----

Rear Panel	37
------------------	----

Basic Printing Flow.....39

■ Workflow before Beginning Work.....	39
---------------------------------------	----

Inspecting the Hinges on the Front Covers.....	40
--	----

- Inspecting the Ink Path..... 41
- Supplying Air and Checking the Air Pressure..... 46
- Supplying Water to and Checking the Belt Cleaning Unit..... 47
- Checking Operating Parts 48
- Checking the Exhaust Equipment..... 49
- Turning On the Power..... 50
- Nozzle Check..... 51
- Head Cleaning 55
- Flushing..... 56
- Print Workflow 58**
 - Setting the Fabric 58
- Passing the Fabric Through This Machine 82**
 - When applying tension to the fabric (path for standard fabrics)..... 82
 - When not applying tension to the fabric (path for fabrics with elasticity) 83
 - Setting the Printer 84
 - Setting the Fabric Thickness and Print Head Height 86
 - Setting the Print Data..... 87
 - Printing..... 93
 - Setting the Belt Speed while Printing 94
 - Replacing Ink Cartridges..... 95
- Workflow When Turning Off the Power 100**
 - Cleaning..... 100
 - Turning Off the Power..... 100
 - Closing the Water Supply Valve..... 102
 - Closing the Air Supply Valve of the Air Supply Regulator..... 102

Maintenance..... 103

- Before Starting Maintenance Work..... 103**
 - Safety Precautions..... 103
 - Wearing of Personal Protective Equipment..... 107
 - Machine Status During Maintenance Work 107
 - Checks Before Maintenance Work..... 108
 - List of Maintenance Tools and Supplies 111
- Maintenance Work List 114**
 - Inspection/Cleaning..... 114
 - Replacing Consumables..... 115
 - Other Maintenance..... 116
 - Print Head Replacement 116
- Inspection/Cleaning Procedure..... 117**
 - Checking the Area Around Operating Parts 117
 - Checking the Operation of the Emergency Stop Equipment..... 117
 - Checking the Regulator Water Level of the Compressed Air Route..... 119
 - Inspecting for Leaks in the Ink Path..... 120
 - Cleaning Caps, Wipers, and Flushing Plate (Home)..... 120
 - Cleaning the Flushing Plate (Full) 127
 - Cleaning the Area Around the Print Heads..... 130

Cleaning the Print Head Cover	135
Checking the Height with the Foreign Material Detection Sensor	139
Cleaning the Cleaning Brushes and the Area Around Them	140
Adding Grease to the Scan Spindle	142
Checking for Water Leaks in the Pipe Joints	145
Checking the Regulator in the Carriage Pressure Air System	146
Cleaning/Replacing the Mist Filter	148
Cleaning/Replacing the Cooling Fan Filters	149
Checking the Blower and Cleaning/Replacing the Filter	154
Checking the Cable Protection Condition	156
Cleaning Around the Image Quality Adjustment Camera	157
Inspecting the Hinges on the Front Covers	161
■ Replacing Consumables	164
Replacing the Washing T-shaped Scraper	164
Replacing the Washing Silicone Scraper	169
Replacing the Wiper	170
Replacing the ink tubes for the pump	174
Replacing the Cap Unit	180
■ Other Maintenance	187
Applying anti-foaming agent to the belt cleaning unit (only when using acid ink)	187
Glue Removal	192
Glue Application	212
Shaking the Ink Cartridges	242
■ Print Head Replacement	245
Cleaning the Head Nozzle Surface (Clean Stick)	245
Cleaning the Head Nozzle Surface (NOZZLE RECOVERY JIG)	252
Print Head Replacement	256

***Problem Solver*** 307

■ If a Message Is Displayed	307
■ Troubleshooting	309
When Printed Colors are Different	309
Printing While the Nozzles Are Still Clogged	310

***Specifications*** 313

■ Basic Specifications	313
■ Printing Width	314
■ Power	315
■ Supported Ink	317
■ Ink Cartridges	319
■ Consumables	320
■ Options	321

Appendix..... 323

■ Screen Reference..... 323

Main Screen323

Printing.....325

Maintenance.....332

System333

DC Agent for ML-64000335

Job List Manager.....336

Safety and Accident Prevention

This section provides information regarding safety and accident prevention.

Before Use

This manual provides important safety information, describes the symbols that are used both in this manual and on this machine, and explains the basic procedures for operating this machine.

Be sure to read this manual carefully before using this machine. Store this manual in a safe location where it can be easily referred to whenever you have a question.

Online manuals are available from your dealer or Epson Support.

Meaning of Symbols

The following warning symbols are used in this manual and on this machine to indicate hazardous operations, to ensure that this machine is used safely and correctly in order to prevent injury to the user and other people and damage to property.

Please carefully read and understand these warnings before using this machine.

Symbols in This Manual

**WARNING:**

This symbol indicates content where mishandling the machine by ignoring this symbol can result in death or serious injuries.

**CAUTION:**

This symbol indicates content where mishandling the machine by ignoring this symbol can result in injury or property damage.

Note:

This symbol indicates a supplementary explanation or additional information that the user should know.

Indicates actions you must not do (prohibited actions).	Indicates things you must do (instructions, actions).	Do not disassemble	Do not touch	Fire strictly prohibited

Eye protection required	Protective gloves required	Protective clothing required	Respiratory protection required	Hair net required

Safety shoes required

Symbols on This Machine

Absolutely do not remove the warning labels applied to this machine. If a warning label becomes illegible or is removed, contact your dealer or Epson Support for a replacement label.

CAUTION: Risk of electric shock	CAUTION: High temperatures	CAUTION: Risk of pinching or crushing fingers	CAUTION: Risk of hand injury	CAUTION: Risk of becoming caught between parts

CAUTION: Risk of becoming pulled into machine	CAUTION: Strong magnetic field	Do not operate without guard	No pacemakers	CAUTION: Strong magnetic field

Alternating current	ON (power)	OFF (power)	Protective ground

Warning Labels

Labels are affixed to the machine to draw attention to dangerous locations.

Front



Rear

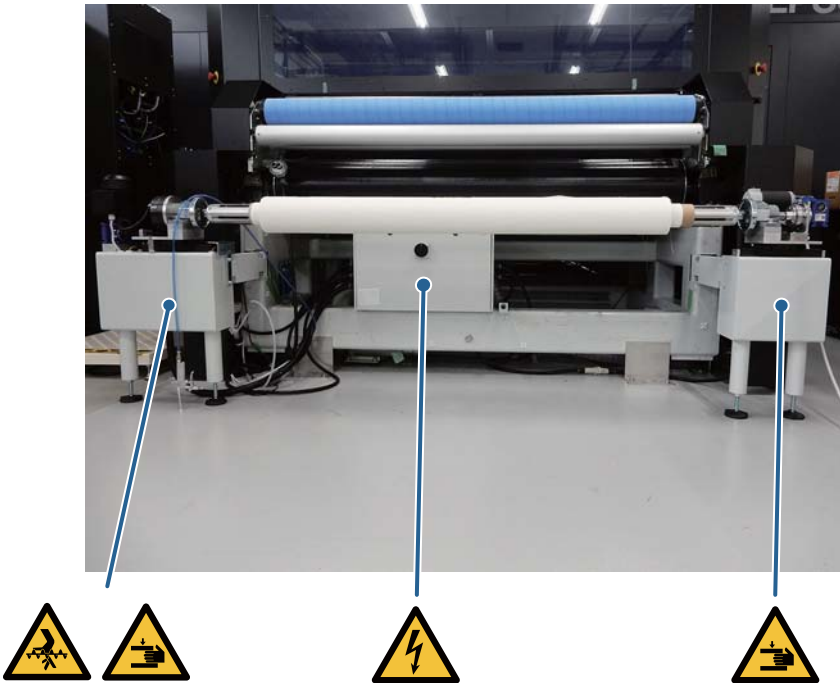

Side (Home side)

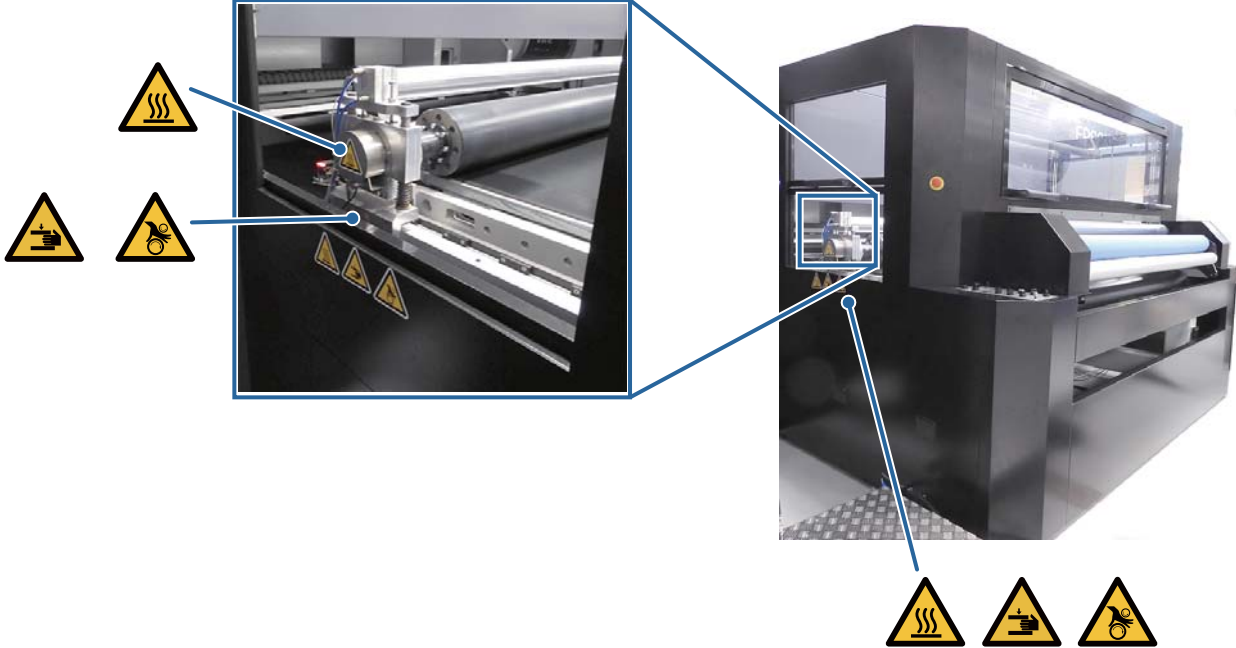

Side (Fullside)

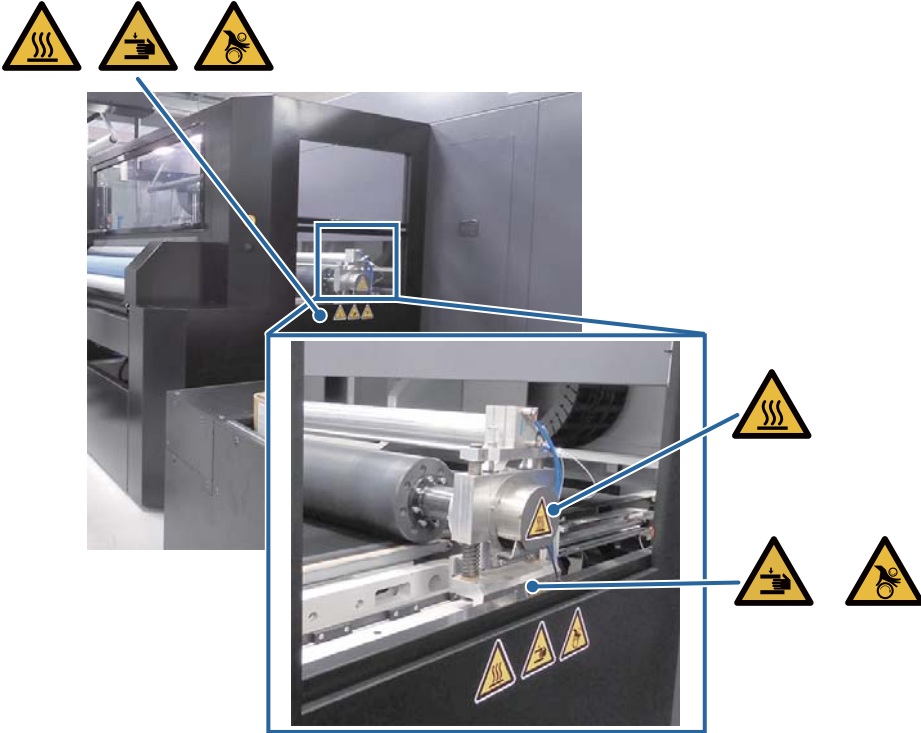

When opening the front covers

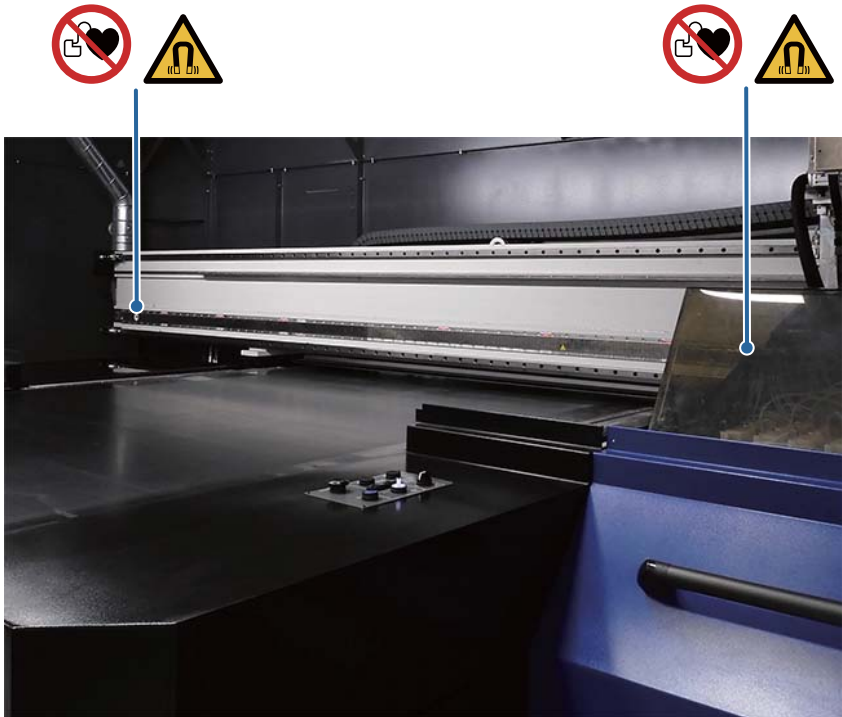







Main electric box















Safety Information



This section provides information that must be observed in order to use this machine safely and prevent injury and/or property damage.







General Precautions



 WARNING	
	Use a power cord that meets the safety standards for the region in which this machine is used.
	Contact your dealer or Epson Support before connecting a new earth terminal.
	Install this machine on a flat, stable surface that is wider than the machine and that can safely support its weight. Contact your dealer or Epson Support for assistance before moving this machine. There is a risk of injury if this machine tips over. There is a risk of electric shock or fire if cables become damaged. Expected performance levels might no longer be guaranteed if changes are made to the condition of this machine.
	Do not use this machine near flames or volatile substances such as alcohol and thinner. Otherwise, there is a risk of electric shock or fire.
	Do not use this machine in environments where flammable gas or explosive gas might be present. In addition, do not use flammable gas sprays in or near this machine. Otherwise, there is a risk of fire.



 CAUTION	
    	<p>Be sure to wear personal protective equipment (gloves, work clothes, safety shoes) when operating this machine. Long hair should be tied back and worn under a hair net. Otherwise, your hands and clothing could become stained with ink, and your fingers and hair could become caught in the machine.</p>
    	<p>Wear eye protection, protective gloves, protective clothing, and respiratory protection when applying or removing glue. For details, refer to the instructions on the Safety Data Sheet (SDS) for the glue and glue remover that you are actually using, and be sure to use the required protective equipment.</p>
	<p>For safety management, the person in charge of managing devices should manage the hardware key for the main electric box.</p>

Handling Precautions

 WARNING	
	<p>Immediately stop using this machine if there is smoke, unusual odors or sounds, or any other abnormal conditions. Otherwise, there is a risk of electric shock or fire. If an abnormal condition occurs, immediately turn off the main power, cut off all power supplied to the machine, and contact your dealer or Epson Support for assistance.</p>
	<p>Do not attempt any repairs yourself. Doing so is extremely dangerous.</p>
	<p>Do not insert or drop metallic or flammable items into any openings on the machine. Otherwise, there is a risk of electric shock or fire.</p>

	Do not touch any areas inside this machine other than those that are indicated in this manual. Otherwise, there is a risk of electric shock or burns.
	Do not remove any parts other than those that are indicated in this manual, and do not install, disassemble, or modify any parts other than those specified. Otherwise, you could be injured or an accident could occur due to abnormal heat or electric shock.
	Do not deliberately remove or disable safety devices. Doing so leads to the risk of injury, malfunction, and/or damage to the machine.
	Do not operate this machine or the computer while maintenance is being performed. Doing so leads to the risk of your hand or other parts of your body becoming caught in the machine.
	Keep your hands away from moving parts, such as the belt, pressure roller, cleaning tank chain, and vertically moving parts of the cleaning tank, while the machine is operating. Otherwise, there is a risk of your hands, hair, or clothing becoming caught in the machine.
	Do not operate this machine if you have a pacemaker. The electromagnetic waves that are generated by this machine can affect the operation of pacemakers.
	This machine generates a strong magnetic field. Do not use precision equipment such as watches and mobile telephones nearby. Precision equipment could malfunction or become damaged by the strong magnetic field.

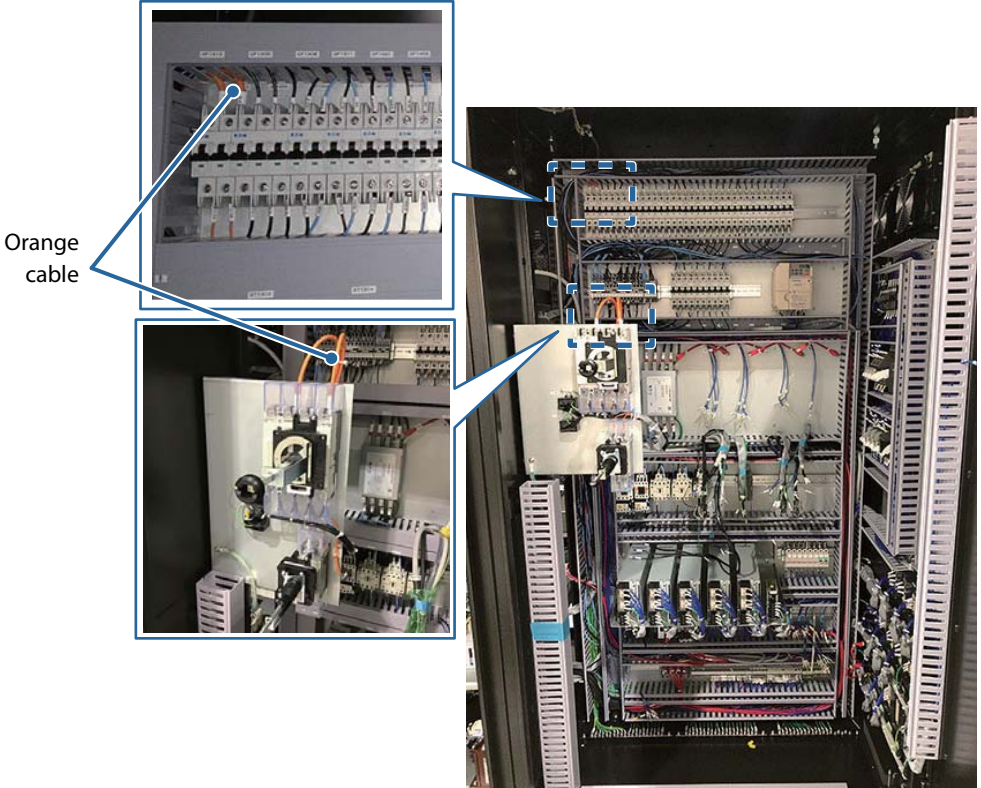
 CAUTION	
	Be careful to avoid pinching your hands and fingers or hitting your head on the corner of the protection covers when opening and closing the protective covers on this machine. Failure to do so could lead to injury.
	The setting and removal of fabric rolls should be performed by two people. When lifting the fabric roll, make sure you bend your knees sufficiently and lift in a natural position. Fabric rolls weigh 30 kg or more. Dropping a fabric roll can lead to injury. Lifting with incorrect posture can lead to injury and/or back pain.

	<p>Do not touch the orange cable in the main electric box. It is live even when the power is off. There is a risk of electric shock.</p>  <p>Orange cable</p>
	<p>Before opening the main electric box door, turn the main power switch on the main electric box to 0 (OFF) and wait 10 seconds.</p>

Notes When Not Using the Printer

- A service engineer must do pre- and post-maintenance when the printer is not used for over 6 weeks. Pre- and post-maintenance will be provided for a fee. During pre-maintenance, the ink in the ink tubes is removed, and the inside of the tubes is washed using the cleaning fluid in the cleaning cartridge, to prepare for long-term storage. When restarting use of the printer, recharge the printer with ink. Moreover, depending on the environment and length of time stored, repairs may be required during post-maintenance even if pre-maintenance is done. If repairs are necessary, they will be done for a fee. Contact your dealer or Epson Support.
- Depending on the type of ink, you may need to remove and shake the ink cartridges installed in the machine if they have not been used for a long period of time.
For more information, refer to ["Shaking the Ink Cartridges" on page 242](#).

Regular Replacement Parts for Maintaining Safety

The front cover hinges should be checked during daily inspections and replaced after the indicated number of years have passed.

Continuing to use this product without replacing the hinges could lead to injury if a front cover falls.







A message is displayed on the screen of the control PC when the number of years indicated for replacement have passed. Check the code number and part ID, and then contact your dealer or Epson Support.

For more information, refer to ["Inspecting the Hinges on the Front Covers" on page 161](#).

Cautionary Information Regarding Consumables (Ink, Cleaning Liquid, Maintenance Liquid) and Waste Ink

Read the Safety Data Sheet (SDS) before handling ink cartridges*, maintenance liquid*, and waste ink. The Safety Data Sheet can be downloaded from the Epson website.

* These are consumable items (sold separately).

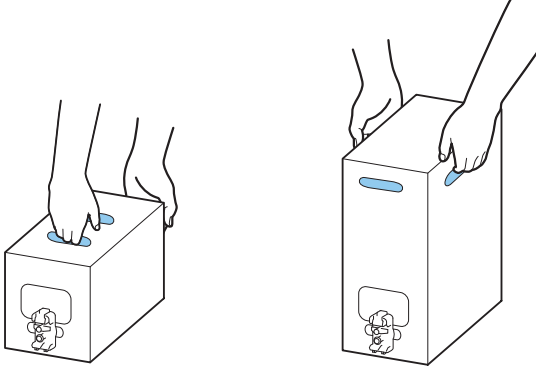
 WARNING	
	<p>If ink gets on your skin or enters your eyes or mouth, take the measures below.</p> <ul style="list-style-type: none"> • If it gets on your skin, rinse immediately with soap and water. • If it enters your eyes, rinse immediately with water. Failure to observe this precaution could result in bloodshot eyes or mild inflammation. If problems persist, consult with a physician. • If it enters your mouth, consult a physician immediately.
	<p>Do not disassemble or modify the ink cartridges. Otherwise, fluid could get in your eyes or come in contact with your skin.</p>
	<p>Keep ink cartridges, maintenance liquid, cleaning liquid, waste ink, and glue out of the reach of children.</p>
 	<p>When lifting up an ink cartridge, wear safety shoes and place your hands in the positions indicated in the figure below. Lifting with placing the hands on other positions could cause the ink cartridge to fall or pinch your fingers when you lower it, resulting in injury.</p> <div style="text-align: center;">  </div>











CAUTION



Wear eye protection, protective gloves, protective clothing, and respiratory protection when performing maintenance work.

Precautions Regarding the Handling of Ink Cartridges

 CAUTION	
	Do not touch the IC chip on any ink cartridge.
	Store ink cartridges within the indicated temperature range. Do not store them in high or freezing temperatures.
	Do not use reactive ink, acid ink, dispersion ink, and pigment ink at the same time (including ink penetration liquid).
	Before installing, stir the ink. For more information, refer to "Replacing Ink Cartridges" on page 95 .
	Dispose of used ink cartridges according to local laws and regulations.
	Epson recommends the use of genuine Epson ink cartridge. Epson cannot guarantee the quality or reliability of non-genuine ink. The use of non-genuine ink may cause damage that is not covered by Epson's warranties, and under certain circumstances, may cause erratic printer behavior. For more information about the warranty for this machine, please refer to the delivery specifications or sales contract.
	This machine is designed to stop operating before the ink completely runs out, in order to maintain the quality of the print head. Therefore, a small amount of ink will remain in used ink cartridges. The running cost will vary by usage environment and usage conditions.

Emergency Stop and Pause

Emergency Stop

In the event of an emergency, press an emergency stop button on the machine. There are a total of five emergency stop buttons on the machine: two each at the front and rear of the Home and Full sides, and one in the main electric box.

The machine comes to an immediate stop when an emergency stop button is pressed.

Data that is being printed will be discarded, and will need to be printed again.

Pause

Press the pause button on the machine. There are a total of four pause buttons on the machine: at the left and right ends of the front and rear sides.

If a pause button is pressed, printing is paused and the head comes to a stop on the Home side. Press [Restart] on the screen of the control PC to restart printing.

Product Overview

This chapter provides an overview of the product.

Product Overview

This is a high-speed, high-quality inkjet fabric printer.

The features of this printer are listed below.

- Printing width: 1,800 mm
- Four types of ink (acidic, reactive, dispersion, pigment) for various fabrics
- Equipped with 8 colors of ink
- Large-capacity ink cartridges (10 L)





Name and Function of Each Part

This section describes the name and function of each part.

Front

Home Side

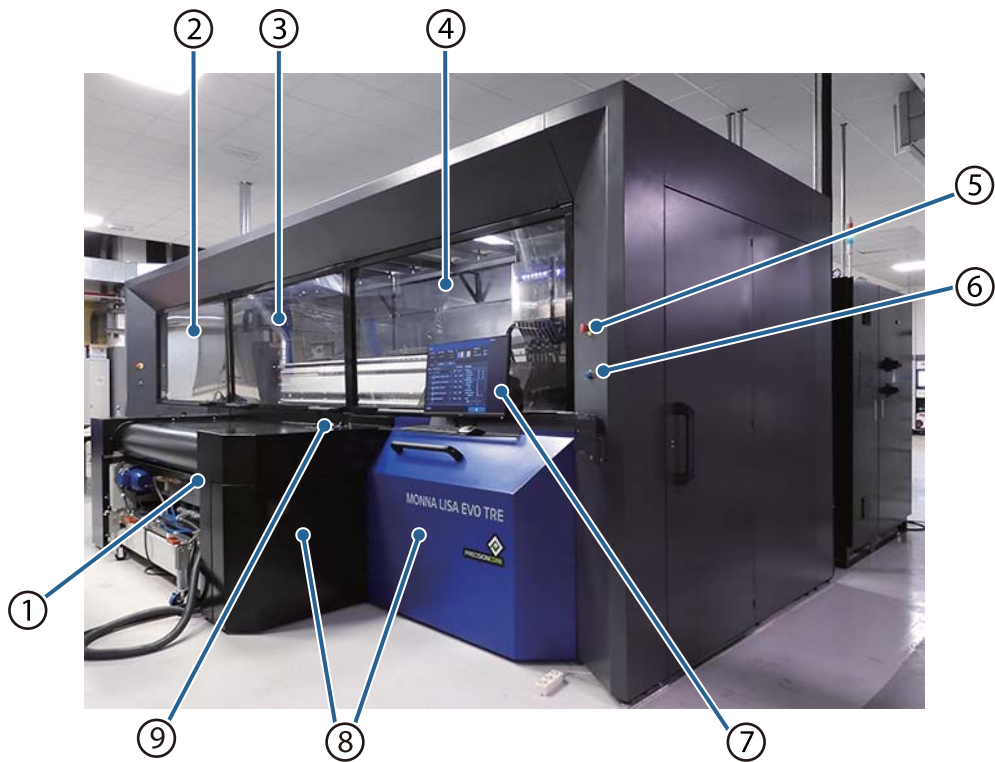

Full Side



No.	Name	Description
1	Tangled Fabric Detection Sensor	If the fabric that is fed from the printer remains affixed to the belt and is likely to become jammed in the belt cleaning unit, this sensor is triggered and operations are stopped.
2	Front cover (Full)	These are movable covers. Open these covers to clean and perform maintenance on the belt, caps & wipers, and flushing plate.
3	Front cover (Center)	
4	Front cover (Home)	
5	Emergency stop button	Stops operation of this machine immediately.
6	Confirm button	Close the side doors and confirm that the safety inside the machine has been confirmed (that no people or obstacles are inside the machine) before pressing this button. Press this button to enable operation of the machine.
7	Control PC	Display for operating the control PC that is used to control the machine. The screen is a touch panel.
8	Maintenance cover	Open this cover to pull out the cleaning station. Pull out the cleaning station to clean and perform maintenance on the head, caps & wipers, and flushing plate.
9	Front panel	Location of the operating panel for performing operations on the front of the machine.
10	Pause button	Printing is paused, the print head stops at the cleaning station, and capping is performed.

Front Section Interior

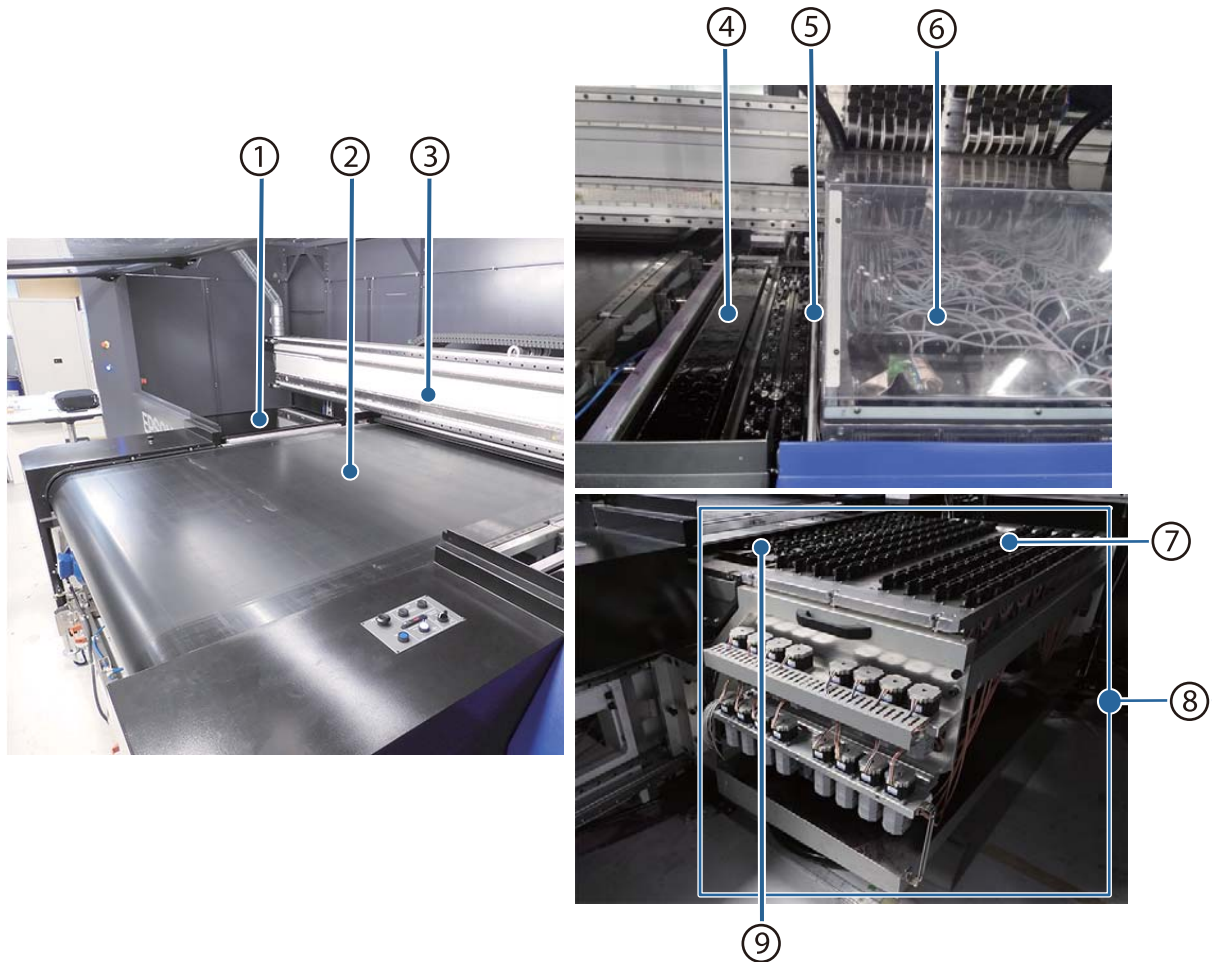

No.	Name	Description
1	Flushing plate (full)	Collects ink discharged from the head to maintain print quality.
2	Belt	This attaches and fixes the fabric for smooth printing and fabric feeding.
3	Scan spindle	Spindle along which the print head moves from side to side.
4	Flushing plate (Home)	Collects ink discharged from the head to maintain print quality.
5	Head stroke sensor	Prevents collisions with the print head by detecting foreign material and whether fabric has curled or lifted.
6	Print head	The print head prints by moving left and right while emitting ink. When print results are dirty, check for dirt stuck to the print head and clean it, if necessary.
7	Cap	Capping is performed to protect the print head and prevent the ink from drying.
8	Cleaning station	Pull out to perform maintenance on the print head, caps, wipers, and flushing plate (Home).
9	Wiper	The print head nozzle surfaces on the print head are wiped to remove ink, fluffy dust, etc.

Sides

Home Side



Full Side



No.	Name	Description
1	Side doors (Home)	These are movable doors. Open the side doors to access the work area inside the printer. Clean and perform maintenance on the head, caps & wipers, and flushing plate.
2	Side doors (Full)	

Side Interior

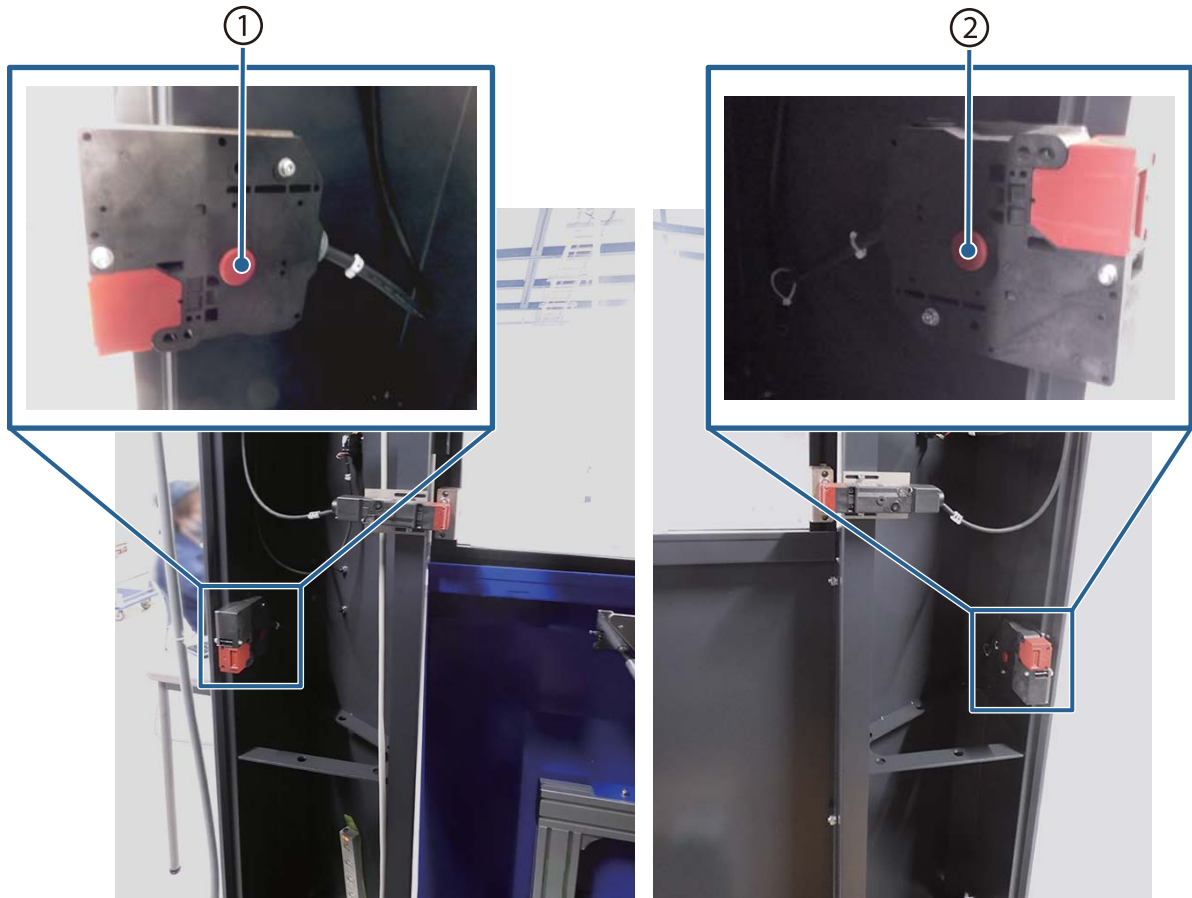

No.	Name	Description
1	Side doors unlock button (Home)	This button is located next to the side door. Press this button to unlock the side doors. If the side doors are locked when you are inside the machine, press this button to unlock the doors so that you can open them.
2	Side doors unlock button (Full)	

Rear

Home Side

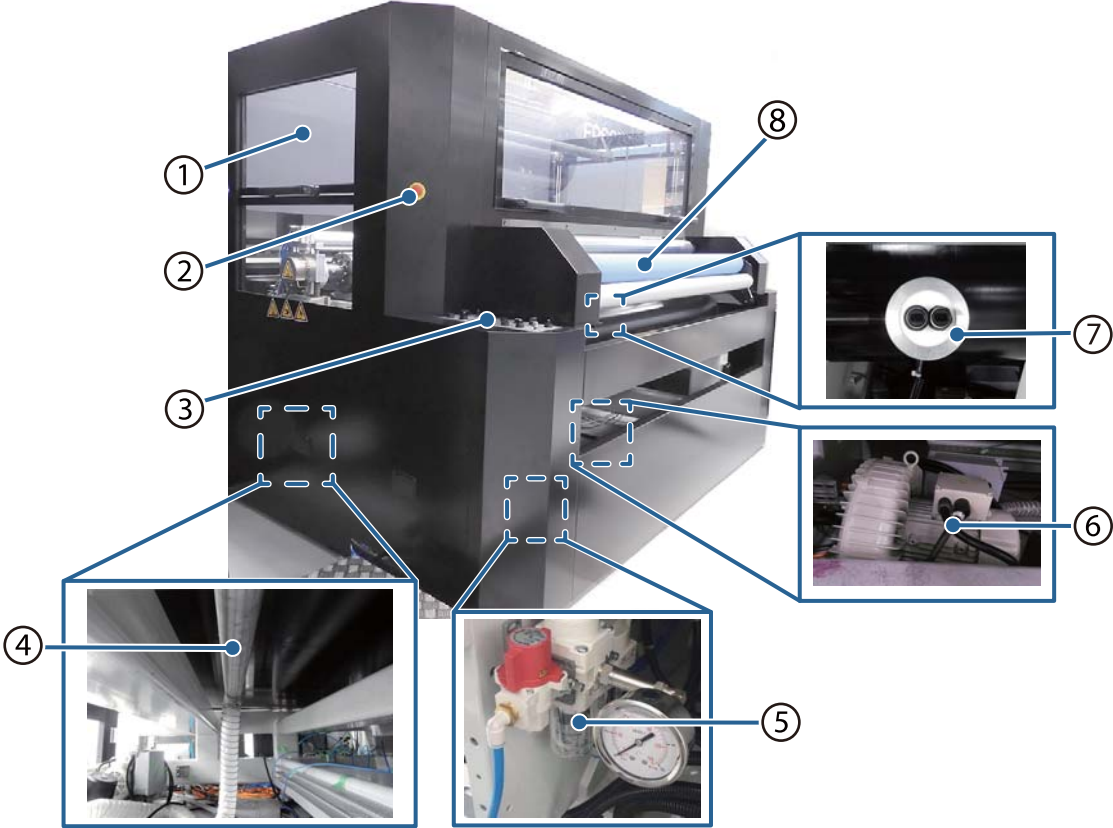

Full Side

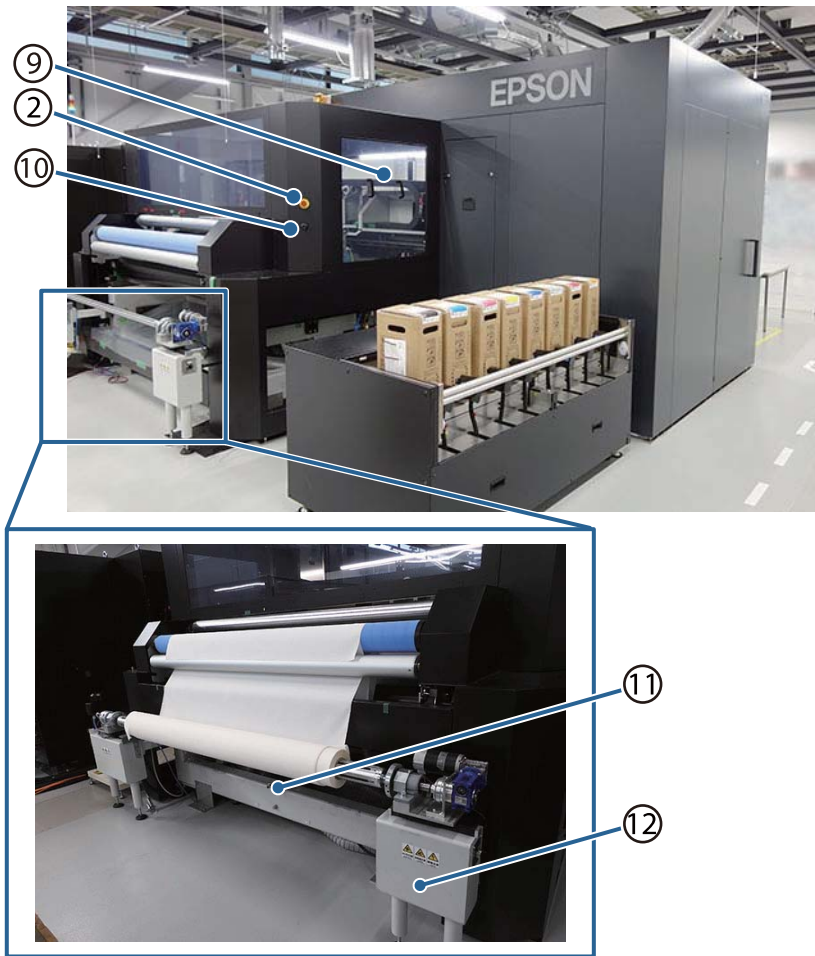

No.	Name	Description
1	Rear cover	The window can be moved up/down. Open this window to load the fabric.
2	Emergency stop button	Stops operation of this machine immediately.
3	Rear panel	Location of the operating panel for performing operations on the rear of the machine.
4	Blower nozzle	Blows air from the blower onto the belt.
5	Air supply regulator	There is a pressure gauge on the regulator that supplies compressed air.
6	Blower	Blows air to dry the water droplets on the belt during belt cleaning.
7	Fabric edge sensor unit	Detects and corrects the fabric if it begins to drift.
8	Tension roller	Applies tension (braking) to the fabric during printing. The tension can be adjusted using the tension adjustment dial on the rear panel.
9	Rear cover	The window can be moved up/down. Open this window to load the fabric.

No.	Name	Description
10	Pause button	Pauses printing. The print head stops on the Home side, and capping is performed.
11	Slack sensor	Detects the amount of slack in the fabric loaded in the optional feeding unit.
12	Feeding unit (optional)	The fabric roll is installed here, and the unit feeds the fabric into the machine.

Rear Interior

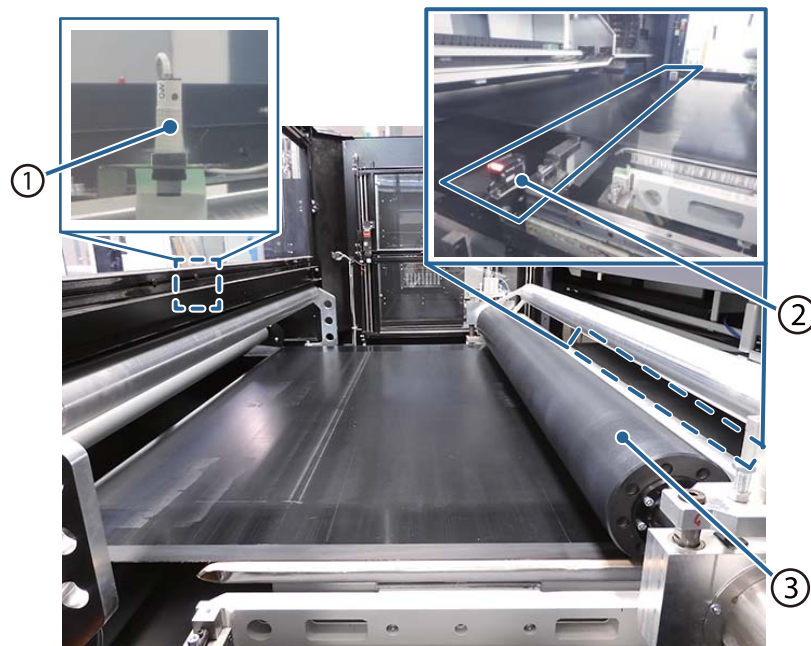



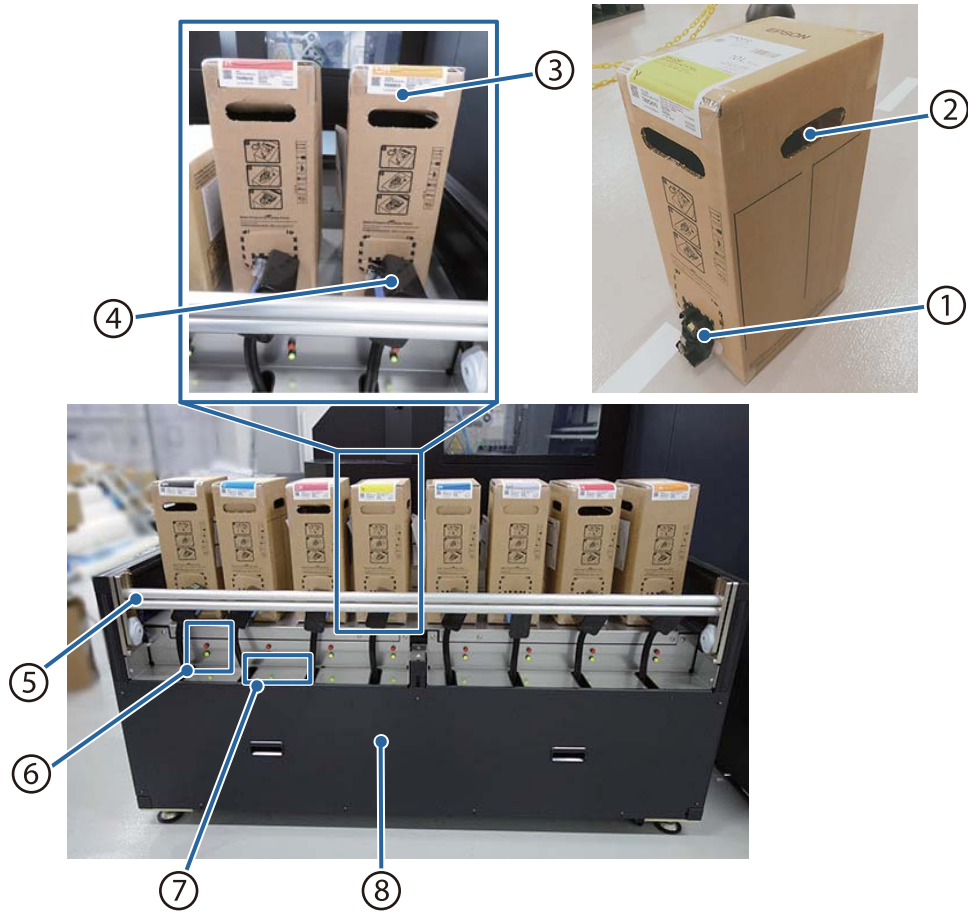

No.	Name	Description
1	Fabric End Detection Sensor	This sensor detects the end of the fabric.
2	Foreign material detection sensor	This sensor uses a laser beam to detect gaps in the thickness of the fabric. If there is any foreign material on the fabric, or if the fabric does not stick to the belt and rises up or flips over, the print head stops to prevent it from colliding with the foreign material or the fabric.
3	Pressure Roller	This roller swings above fabric to de-wrinkle the fabric and affix it to the belt. Selecting [Pressure Roller] on the control PC will allow you to push on the fabric or cut sheets using the pressure roller while the feed button is held.

Ink Rack



No.	Name	Description
1	Ink supply port	Ink from the ink cartridge comes out of here. Pull this out from inside the new ink cartridge, and then insert the ink cartridge.
2	Handles	Grasp this with your hand to hold the ink cartridge. With new products, the holes are shut, so open the holes by pressing them with your hand. Located in four places on the sides of the ink cartridges.
3	Ink cartridge	Filled with 10 L of ink.
4	Connector	This is the supply port for supplying ink from the ink cartridge.
5	Ink rack front bar	Pull this bar down when replacing ink cartridges. It prevents ink cartridges from falling out, and to normally stop the supply of ink.
6	Cartridge check lamp	These lamp indicators change according to the status of the ink rack front bar and ink cartridges.
7	Holder	Base for placing connectors when replacing ink cartridges.
8	Ink Rack	Supplies the ink in the ink cartridges. Holds ink cartridges for 8 colors.

How to read the cartridge check lamp

	Green lamp on	Ink is being supplied to the printer. Do not remove the ink cartridges.
	Green lamp flashing	There is ink remaining in the ink cartridge, and the ink rack front bar is open.
	Red lamp on	There is no ink remaining in the ink cartridge.
	Red lamp flashing	There is no ink remaining in the ink cartridge, and the ink rack front bar is open.

Belt Cleaning Unit

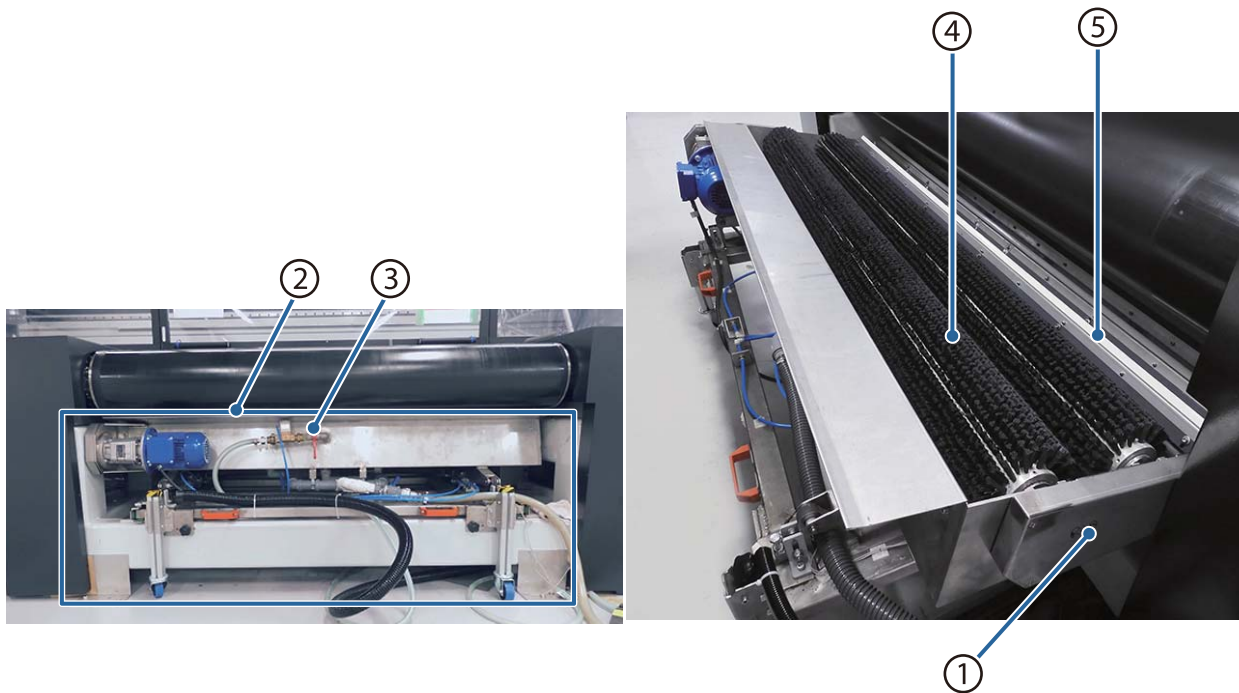

No.	Name	Description
1	Belt cleaning tank	Stores water when cleaning the belt.
2	Belt cleaning unit	This unit cleans ink and other foreign material adhering to the belt. Open this cover to clean the cleaning brushes and washing scraper.
3	Water supply valve	Open to supply water to the belt cleaning tank.
4	Cleaning brushes	Brushes away ink and other foreign material adhering to the belt. Selecting [Belt Cleaning] on the control PC will allow you perform belt cleaning while the feed button is held.
5	Scraper	Wipes away water droplets after belt cleaning.

Main Electric Box

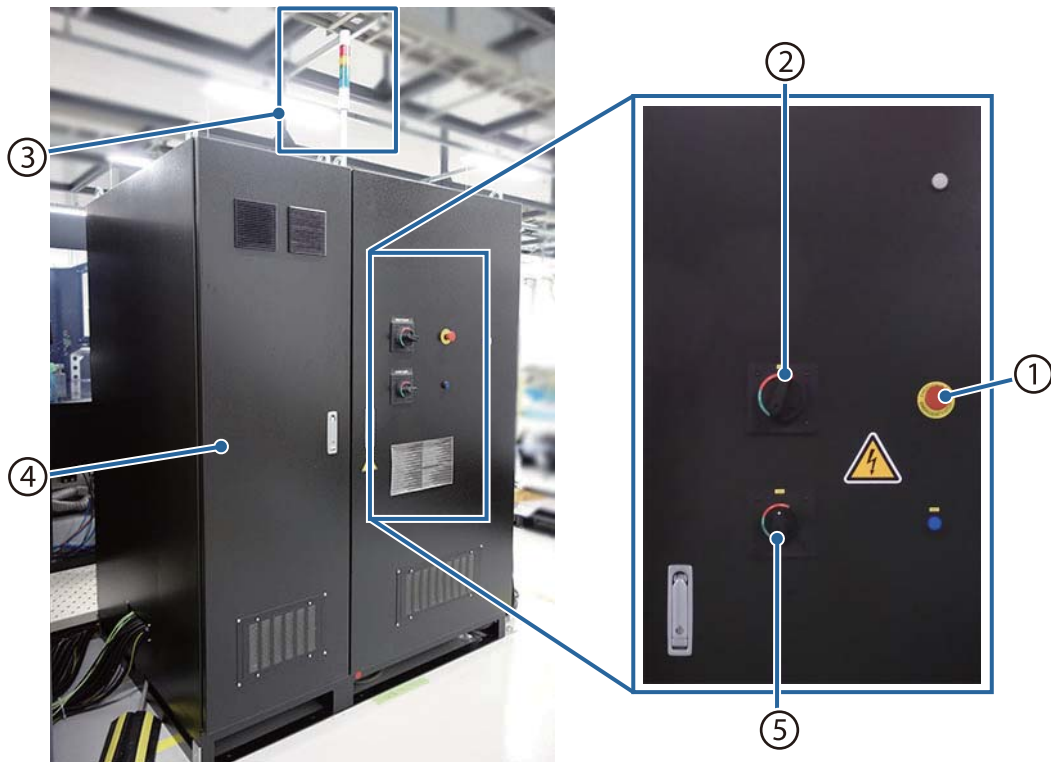

No.	Name	Description
1	Emergency stop button	Stops operation of this machine immediately.
2	Main power switch	Used to switch on/off the power to the main unit.
3	Signal lamp	<p>Lamps light or flash in 3 colors to notify you of the status of the printer. Basically, the meaning of the lamps' colors are as follows.</p> <p>The color of the lamps, in order from top to bottom, are red, yellow, green, and blue.</p> <p>Red: Fault status (Emergency stop or device error) Yellow: Abnormal status (Restart possible) Green flashing: Normal operation by the user, such as printing, returning origin, belt cleaning, etc. Green on: Standby condition Blue: Forced status (Operation required by operator)</p> <p>The printer notifies you about its status in detail with a combination of lamp colors and lighting/flashing.</p>
4	Main electric box	Supplies power and houses the control PC.
5	Inside light switch	Switch for the light inside the machine. This light can be turned on even if the main power switch is turned off.

Front Panel



No.	Name	Description
1	Backfeed button	Press and hold this button to feed the belt in the reverse direction.
2	Feed button	Press and hold this button to feed the belt in the forward direction. Selecting [Pressure Roller] on the control PC will allow you to push on the fabric using the pressure roller while the feed button is held. Selecting [Belt Cleaning] will allow you perform belt cleaning while the feed button is held.
3	Pause button	Printing is paused and the print head stops at the cleaning station.
4	Foreign material detection sensor switch	Use this switch to turn on/off the foreign material detection sensor.
5	Foreign material detection sensor controller	Use this display to set the detection threshold value of the foreign material detection sensor and display the threshold value.
6	External winder switch	Use this switch to enable/disable the signal from an external winder.

Rear Panel

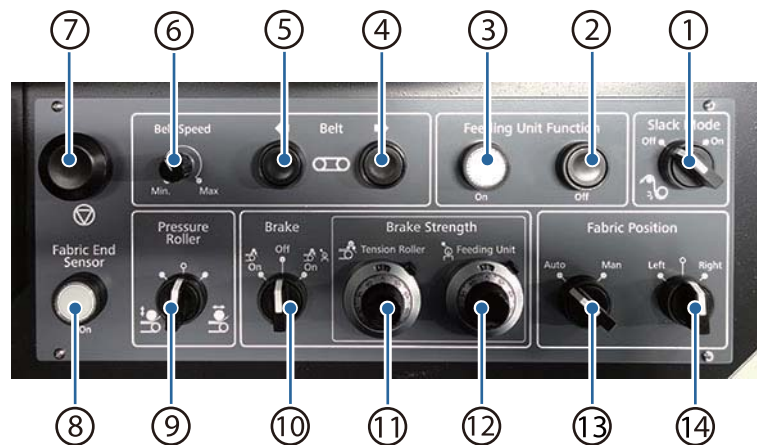

No.	Name	Description
1	Slack detection switch	Use this switch to change the operation of the slack detection sensor. Off: Disable On: Enable
2	Feeding unit Off button (Off)	Turns off signals from external devices, such as the feeding unit.
3	Feeding unit button (On)	Turns on signals from external devices, such as the feeding unit.
4	Backfeed button	Press and hold this button to feed the belt in the reverse direction.
5	Feed button	Press and hold this button to feed the belt in the forward direction. Selecting [Pressure Roller] on the control PC will allow you to push on the fabric using the pressure roller while the feed button is held. Selecting [Belt Cleaning] will allow you perform belt cleaning while the feed button is held.
6	Belt speed volume	Use this knob to adjust the belt speed.
7	Pause button	Printing is paused and the print head stops at the cleaning station.
8	Fabric end sensor button	Printer detects the end of the fabric and then pauses printing.

No.	Name	Description
9	Pressure roller switch	<p>Use this switch to set the operation of the pressure roller.</p> <p>Left: Moves the pressure roller up/down. Each time the switch is turned to the left, the pressure roller moves up/down. However, the roller moves up automatically if it was down for a given amount of time when the belt is stopped.</p> <p>Right: Moves the pressure roller forward/backward. Turn to the right to operate, or to the left (12 o'clock position) to stop the pressure roller. The roller stops in the up position when stopped.</p>
10	Tension switch	<p>Use this switch to turn OFF/ON the tension roller (which adds tension to prevent wrinkles in fabric) and feeding unit.</p> <p>Left: Tension roller: ON / Feeding unit: OFF Middle: Tension roller/Feeding unit: OFF Right: Tension roller/Feeding unit: ON</p>
11	Tension adjustment dial (tension roller)	<p>Adjusts the tension applied to the fabric by the tension roller. Raise the tension if wrinkles still occur in the fabric. Perform adjustments while watching the tension meter.</p> <p>Turn to right: Raises the tension. Turn to left: Lowers the tension.</p>
12	Tension adjustment dial (feeding unit)	<p>Adjusts the tension applied to the fabric by the feeding unit. Raise the tension if wrinkles still occur in the fabric. Perform adjustments while watching the tension meter.</p> <p>Turn to right: Raises the tension. Turn to left: Lowers the tension.</p>
13	Fabric position adjustment switch (Auto)	<p>Use this switch to set fabric feeding position adjustment to AUTO/MAN (MANUAL).</p> <p>Auto: Fabric feeding position is adjusted automatically. Man: Fabric feeding position is adjusted manually. This cannot be used if an external feeding unit is connected.</p>
14	Fabric position adjustment switch (LR)	<p>Use this switch to move the fabric feed position left and right. It is enabled when the fabric position adjustment switch is set to MAN (MANUAL).</p> <p>Left: Moves to the left. Right: Moves to the right. This cannot be used if an external feeding unit is connected.</p>

Basic Printing Flow

This section describes the items to be checked before beginning work.

Workflow before Beginning Work

1. Inspecting the Hinges on the Front Covers ([Page 40](#))
2. Inspecting the Ink Path ([Page 41](#))
3. Supplying Air and Checking the Air Pressure ([Page 46](#))
4. Supplying Water to and Checking the Belt Cleaning Unit ([Page 47](#))
5. Checking Operating Parts ([Page 48](#))
6. Checking the Exhaust Equipment ([Page 49](#))
7. Turning On the Power ([Page 50](#))
8. Nozzle Check ([Page 51](#))
9. Head Cleaning ([Page 55](#))

Inspecting the Hinges on the Front Covers

Check the hinges on the front covers for damage.

If the hinges are damaged or there are any other abnormalities, such as unusual noise, contact your dealer or Epson Support.

For more information, refer to ["Inspecting the Hinges on the Front Covers"](#) on page 161.

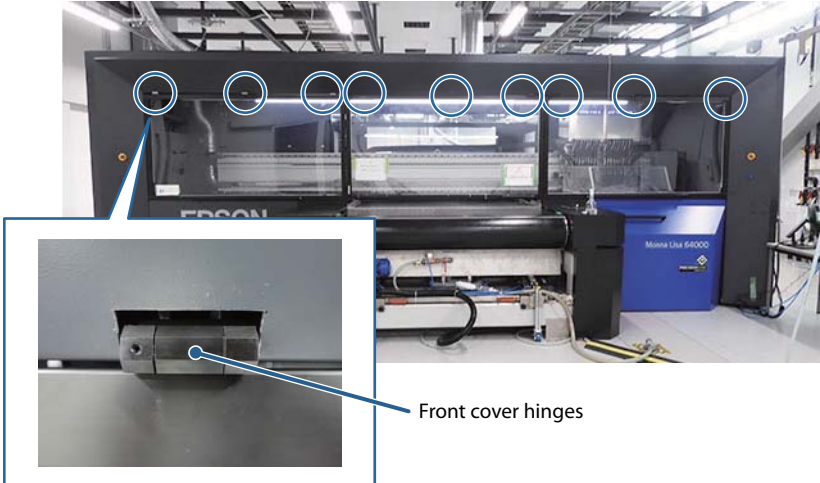

Inspecting the Ink Path

Inspect if there are any ink leaks in each ink path.

Inspection Items

The inspection items are described below.

- Are any ink paths disconnected?
- Is any ink leaking from the connecting parts on each ink path?
- Is there any evidence of ink adhesion/dripping/accumulation in the nearby area?

If any of the above are discovered during an inspection, cleaning and/or replacement is required. For more information, refer to "Inspecting for Leaks in the Ink Path" under "Maintenance".

Print Head

Open the front cover to visually check the area around the ink head.

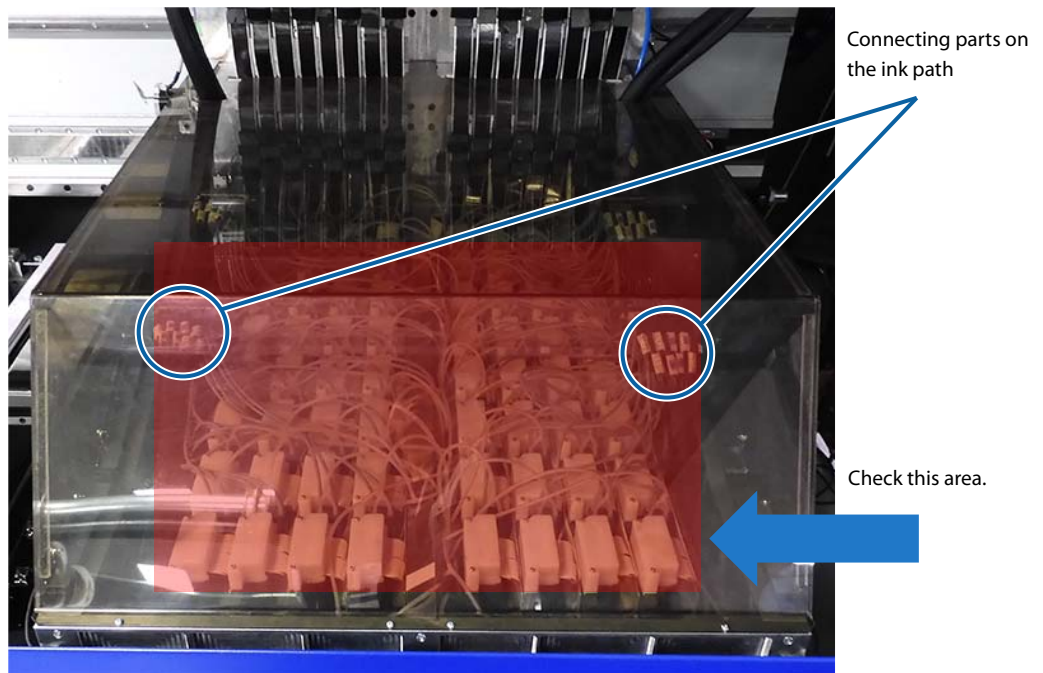

Home Side

- 1 Move the display of the control PC to the outer side.



- 2 Open the front cover (Home) and press the side doors unlock button (Home) inside the side door to unlock the side doors.
- 3 Open the side door (Home) and move into the machine to visually check the area around the cleaning station.

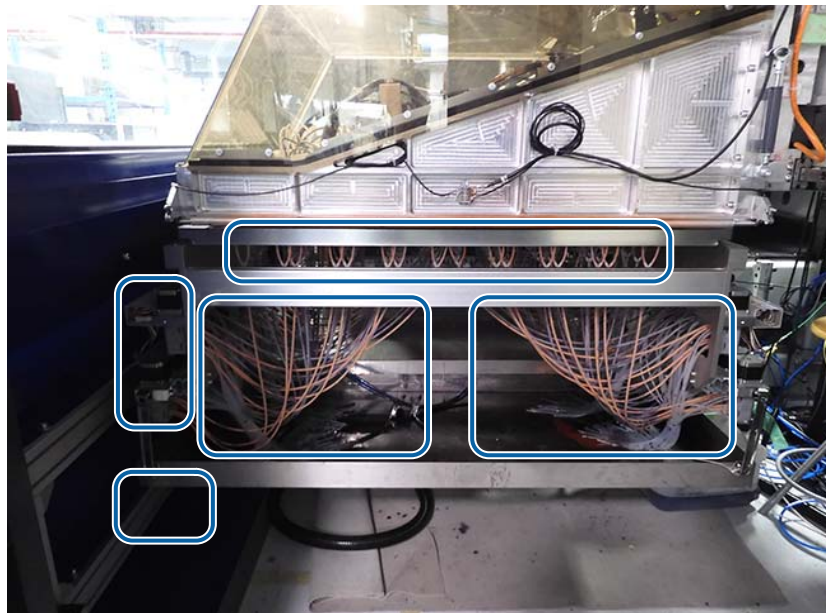

- 4 Pull the side doors unlock button (Home) back to lock the side doors.**

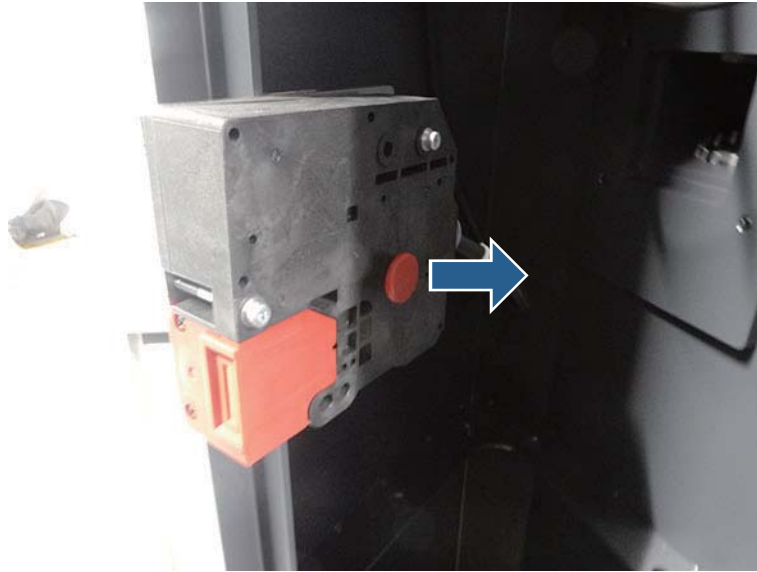

- 5 When the inspection is complete, move out of the machine.**
- 6 Make sure nobody is inside the machine, then close the side door.**
- 7 Check to see if the display of the control PC has been moved to the outer side.**
If it has not been moved, move the display of the control PC to the outer side.
- 8 Close the front cover (Home).**
- 9 Return the control PC to its original position.**

Full Side

- 1** Open the front cover (Full) and press the side doors unlock button (Full) inside the side door to unlock the side doors.
- 2** Open the side door (Full) and move into the machine to visually check the area around the flushing plate (Full).
 - Are waste ink outlets clogged, causing ink to overflow?
 - Are ink paths behind the waste ink outlets disconnected/leaking?
 - Are ink paths to the waste ink equipment disconnected/leaking?



- 3** Pull the side doors unlock button (Full) back to lock the side doors.

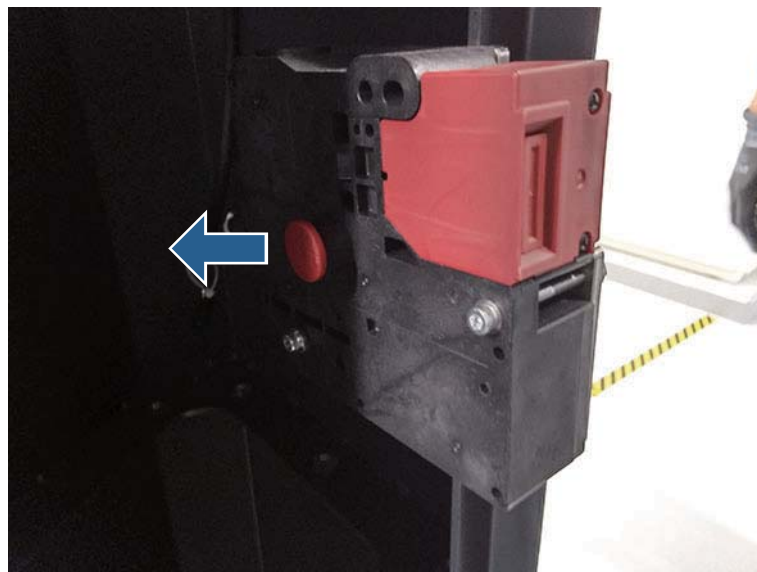

- 4** When the inspection is complete, move out of the machine.
- 5** Make sure nobody is inside the machine, then close the side door.

Ink Rack

Visually check the area around the ink rack and ink cartridges.

- Is ink dripping from the bottom of the ink rack?
- Is ink leaking from connectors?
- Is ink adhered to the ink cartridges?



Supplying Air and Checking the Air Pressure

Compressed air is supplied in order for the machine to operate. The machine will not operate if the specified air pressure is not supplied.

An air pressure that is higher than the specified air pressure could cause the machine to malfunction.

Air Supply Regulator

Open the air supply valve for the air supply regulator at the back of the machine and check that the specified value is reached.

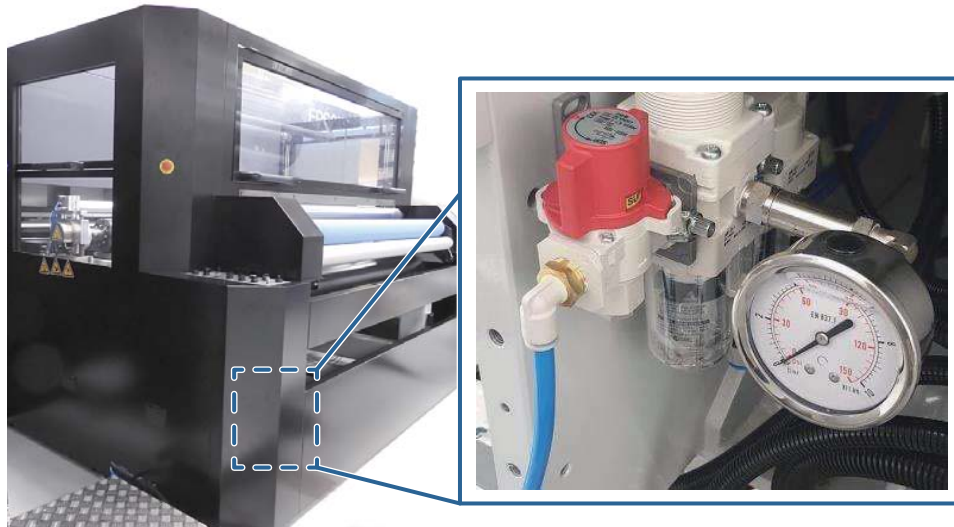

Specified value: 0.55 MPa

If it is not at the specified value, check the status of the compressed air equipment in the factory.

Supplying Water to and Checking the Belt Cleaning Unit

The belt cleaning unit washes ink from the belt.

Opening the Water Supply Valve

Open the water supply valve at the bottom of the front of the machine. Adjust the open/close amount to match the use conditions.

Closed



Checking the Belt on the Belt Cleaning Unit

Check to see if the cleaning brushes and scrapers are dirty or worn.

For more information, refer to the "Maintenance" chapter.

Checking Operating Parts

Do not place tools, fasteners, or the like on the belt or near the pressure roller or print head. Doing so could cause them to be entangled in the belt, pressure roller, or print head, damaging this machine. Before turning the power on, check that there is nothing left near the moving parts, such as on the belt or near the print head.

Front

- 1** Move the display of the control PC to the outer side.
- 2** Open all the front covers of the machine.
- 3** Check that there are no tools, fasteners, or the like left on the belt or near the carriage or print head.

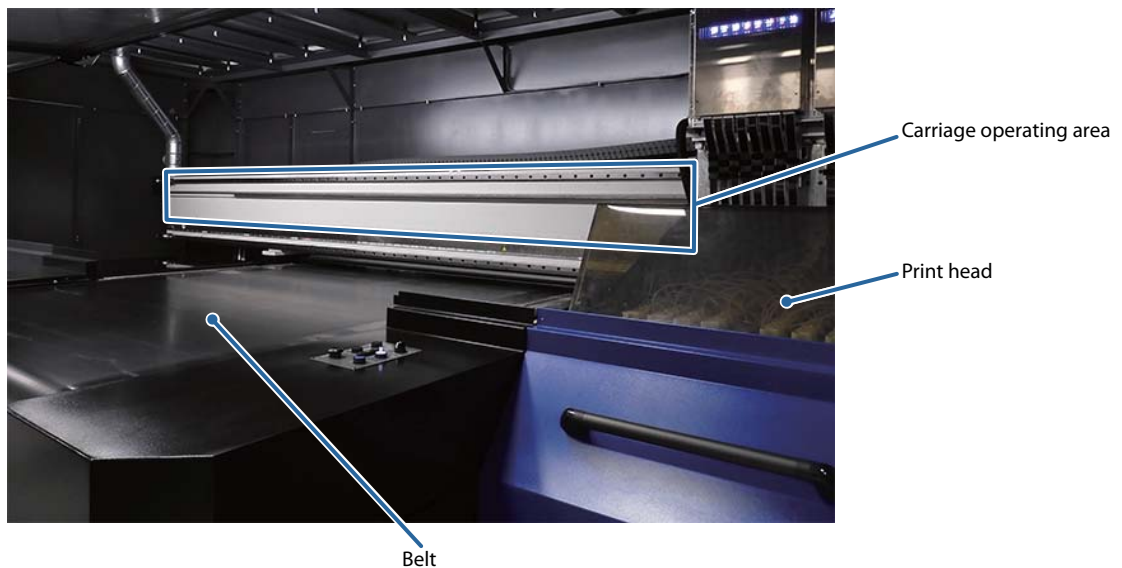

- 4** Check to see if the display of the control PC has been moved to the outer side.
If it has not been moved, move the display of the control PC to the outer side.
- 5** Close all the front covers.

Rear

- 1 Open the rear covers of this machine.
- 2 Check that there are no tools, fasteners, or the like left near the belt or the pressure roller.



- 3 Close the rear covers.

Checking the Exhaust Equipment

Check if the exhaust is flowing while the machine is running, in order to adjust the temperature and humidity of the machine.

The location and method of checking exhaust ducts will vary depending on the equipment that is used. For details, please check with the factory manager.

Turning On the Power

- 1 Turn the main power switch on the main electric box to 1 (ON).



- 2 After confirming that the light is flashing, press the Confirm button on the front side of the machine.
- 3 If a message is displayed on the screen of the control PC, press [Return to Origin].

The signal lamp flashes green until after return to origin operation is completed when the signal lamp lights up green and the screen for operating the machine is displayed.

Nozzle Check

Before printing, perform a nozzle check to make sure that there are no clogged nozzles. If there are clogged nozzles, perform head cleaning.

Note:

Use cut sheets for the nozzle check, because the ink grains are very fine. Fabric can also be used, but makes it difficult to determine if there are clogged nozzles.

Required items:

- Plastic board (bundled item)
- A3 plus (480 x 360 mm) cut sheet x 2 (commercially available)

Setting the Cut Sheets

This procedure is not necessary when printing directly on fabric.

- 1** Place the cut sheets on the plastic board as shown in the image below.



- 2** Change the direction of the plastic board and position it 180 mm from the right edge of the belt on the front of the machine.

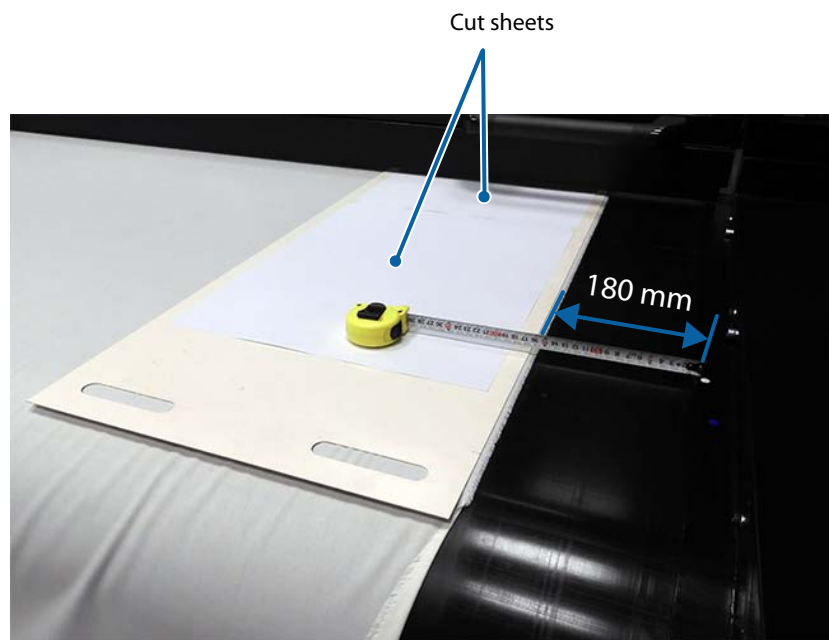

Printing the Nozzle Check Pattern

1 Select [Maintenance] menu - [Print Head] tab on the screen of the control PC.

2 Configure the settings below under Print Nozzle Check Pattern.

Printing Begin: 130 mm
 Fabric Thickness: 1.3 mm (thickness of plastic board)
 Head Height: 0.7 mm (recommended value)

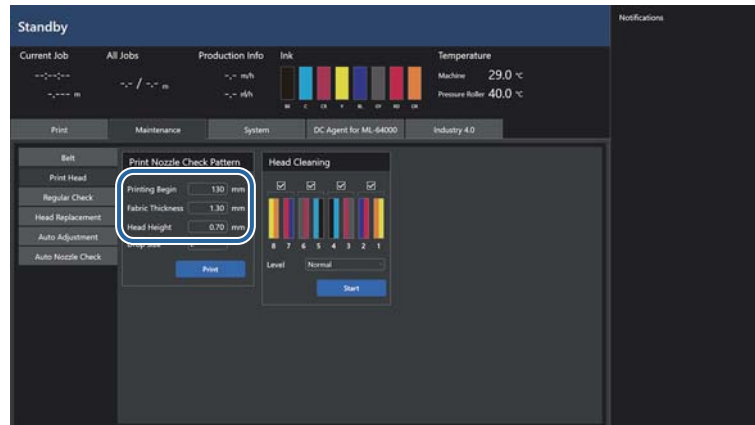

3 Move the plastic board to the printing area.

Press the backfeed button to move the plastic board, and align the edge of the printing area in the Y direction with the edge of the paper.



WARNING:

Make sure the plastic board and cut sheets do not lift up or bend.
 If the plastic board or cut sheets lift up or bend, the print head might hit them and become damaged when printing.

4 Press [Print] to print the nozzle check pattern.

5 "Preparing to Pattern Print" is displayed for the status, and the signal lamp flashes green. The print heads move, and print the nozzle check pattern.

6 Confirm that "Standby" is displayed for the status, and that the signal lamp is green. This completes printing of the nozzle check pattern.

7 Press the feed button on the front panel to feed the belt and bring the plastic board forward.

Note:

You can perform belt cleaning or push on the fabric or cut sheets while the feed button is held.

If you want to perform belt cleaning, then from the control PC, open the [Print] menu and confirm that [Print Settings] - [Device Settings] - [Cut Sheet Mode] (1) is not selected, and then select [Belt Cleaning] (2).

If you want to press on the fabric or cut sheets, then from the control PC, open the [Print] menu and confirm that [Print Settings] - [Device Settings] - [Cut Sheet Mode] is not selected, and then select [Pressure Roller] (3).

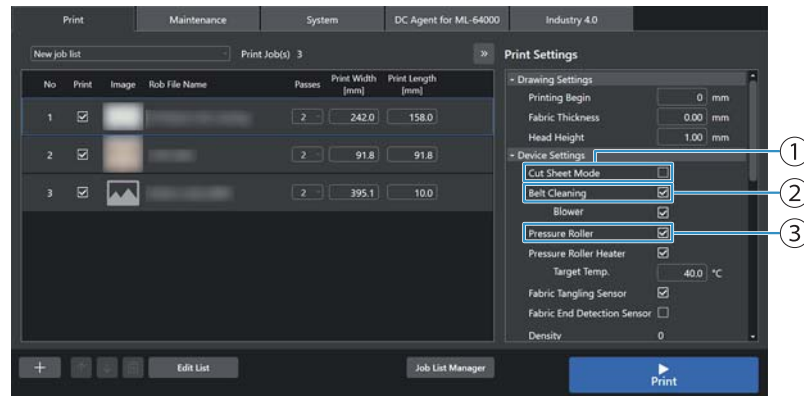

8 Lift up the plastic board, and check the nozzle check pattern that was printed.

If there are no clogged nozzles and operation is normal, all of the lines will be printed.

If there are clogged nozzles (there are areas that are not printed), actual printing could be affected. In that case, perform head cleaning. Refer to ["Head Cleaning" on page 55](#) for the procedure.

If the check pattern that was printed has mixed colors, flushing should be performed. Refer to ["Flushing" on page 56](#) for the flushing procedure.

Head Cleaning

Use the following procedure to perform head cleaning.

- 1 Select [Maintenance] menu - [Print Head] tab on the screen of the control PC.
- 2 Confirm that all 4 check boxes under [Head Cleaning] are selected, and then press [Start].
Change the [Level] setting as necessary.

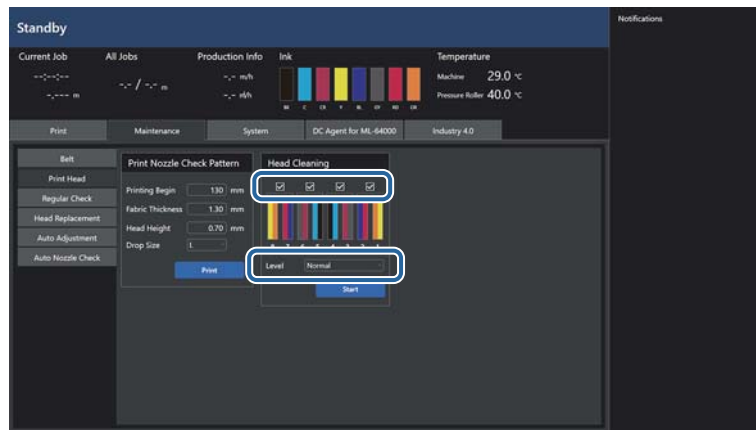

- 3 Head Cleaning is displayed for the status. The signal lamp flashes green. The heads move, and head cleaning starts.
- 4 When head cleaning is complete, "Standby" is displayed for the status.
If nozzles are still clogged even after performing this operation several times, clean the surface of the head or replace the print head. For more information, refer to ["Print Head Replacement" on page 256](#).
If you want to print while the nozzles are still clogged even after performing head cleaning several times, set the number of print heads to be used to 32 heads before printing. Refer to ["Printing While the Nozzles Are Still Clogged" on page 310](#).

Flushing

If the colors in the check pattern are mixed, or if the printed tones are different, the ink colors might be mixing. Follow the steps below to flush the print heads.

- 1 Select [Maintenance] menu - [Print Head] tab on the screen of the control PC.



- 2 Select the print head row(s) with mixed ink colors under [Flushing].

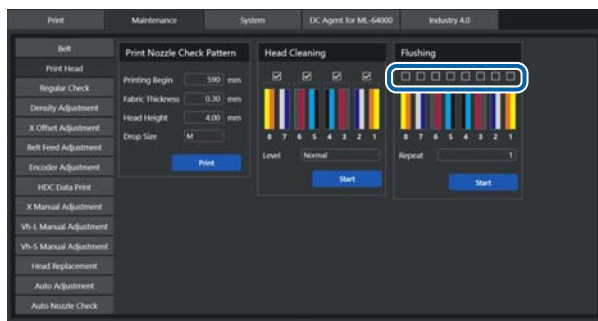

- 3 Press [Repeat] and then set the number of times to [2].

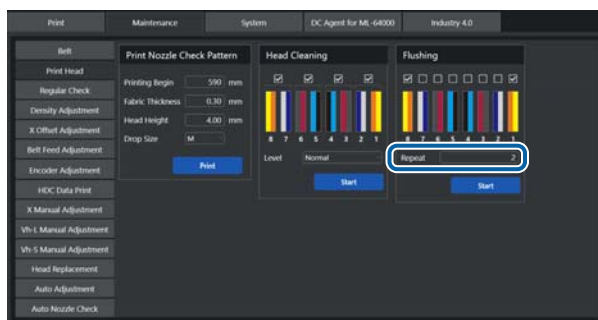

4 Press [Start].

The print heads move to the Full side, and flushing starts. When flushing is complete, the print heads return to the Home side.



5 Print a check pattern to check if the colors are still mixed.

Refer to ["Nozzle Check" on page 51](#) for more information about how to print a check pattern.

If there is no color mixing, the work is complete.

If there is still color mixing, increase the number of repeats and perform flushing again. Start from Step 2. If the problem continues to occur even after performing flushing again, contact your dealer or Epson Support.

Print Workflow

This section describes the procedure for printing.

1. Setting the Fabric ([Page 58](#))
2. Setting the Printer ([Page 84](#))
3. Setting the Fabric Thickness and Print Head Height ([Page 86](#))
4. Setting the Print Data ([Page 87](#))
5. Printing ([Page 93](#))
6. Replacing Ink Cartridges ([Page 95](#))

Setting the Fabric

Preparing the Fabric

Before setting the fabric, be sure to confirm the following status.

- Fabric edge: Confirm that there are no folds or protrusions and that the fabric is not lifted up or frayed. If the fabric is frayed, perform overcasting.
- Seams: Confirm that there are no protrusions and that the fabric is not frayed.



WARNING:

If the fabric touches the print head, the print head may be damaged.

The fabric must be fed and adhere to the belt without any folds, protrusions, seams, or lifting in the fabric edge whatsoever.



WARNING:

When loading the fabric for the first time or changing the fabric thickness, set the foreign material detection sensor threshold and control PC fabric thickness.

For more information about the foreign material detection sensor threshold settings, refer to "[Setting the Printer](#)" on page 84.

For more information about the fabric thickness settings, refer to "[Setting the Fabric Thickness and Print Head Height](#)" on page 86.

If fiber containing moisture from the ink lifts up, it may come into contact with the head passing over the fabric. To avoid this, make the fabric edge adhere firmly to the belt.

Attaching fabric to the feeding unit (optional)



WARNING:

- Fabric should be installed by at least 2 people.
- The fabric must be as smooth and firm as possible. If the fabric edge is fraying and threads are loose, the fiber may come into contact with the print head, damaging the print head. In the same way, be sufficiently careful to prevent protrusions and fraying at the seam between pieces of fabric.

1 Rotate the feeding spindle so that the air inlet is directly above it.

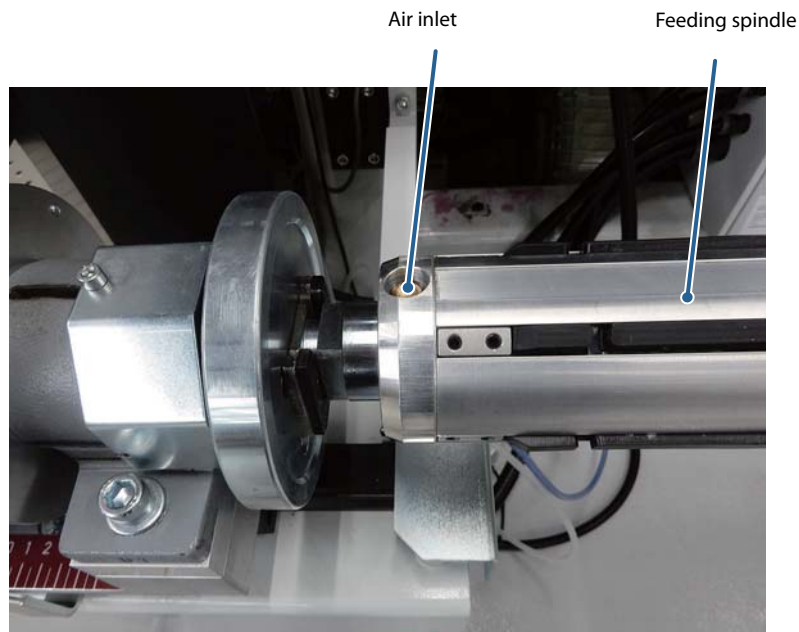

2 Press the center of the air inlet of the spindle to release the air and loosen the stopper on the feeding spindle.

The stopper loosens creating a gap between the fabric's paper core and the feeding spindle.

- 3** Align the groove on the feeding unit so that it is at the top, and then release the locks on the left and right sides of the feeding unit.

The feeding spindle can be removed.

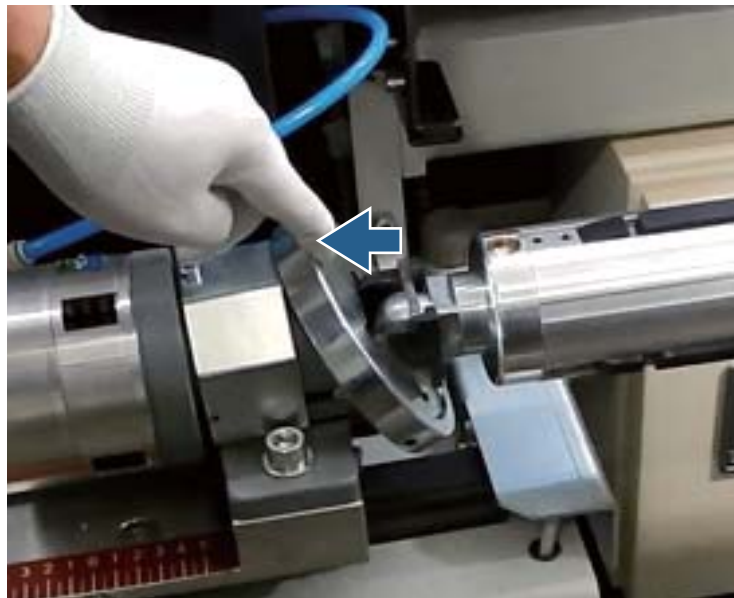
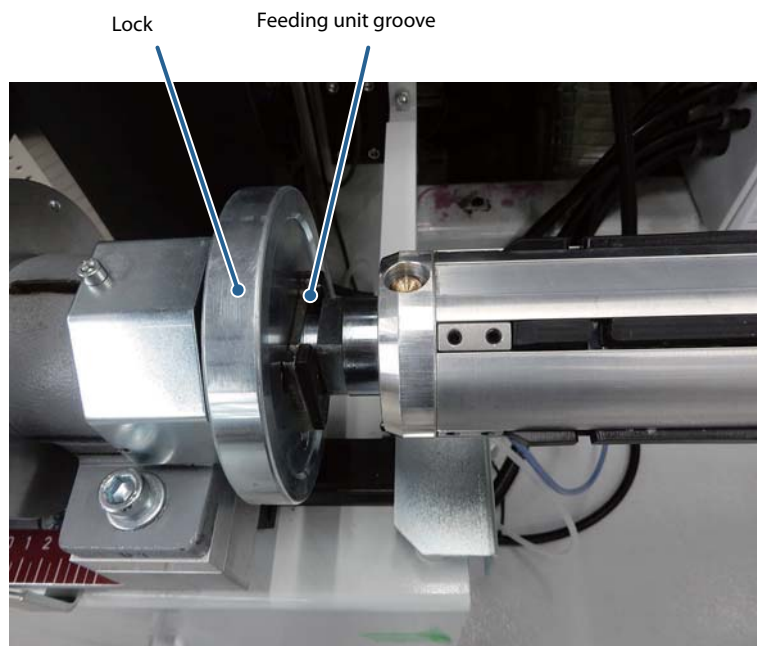

- 4** Remove the feeding spindle, and replace the fabric.

- 5** Load the new fabric on the feeding spindle.

- 6 Load the fabric roll in the feeding unit.**
Align and fit the fabric roll into the groove on the feeding unit.

**WARNING:**

Do not place your hands between the feeding spindle and the feeding unit.
Otherwise, your fingers or hands could get caught in the feeding unit, causing an injury.

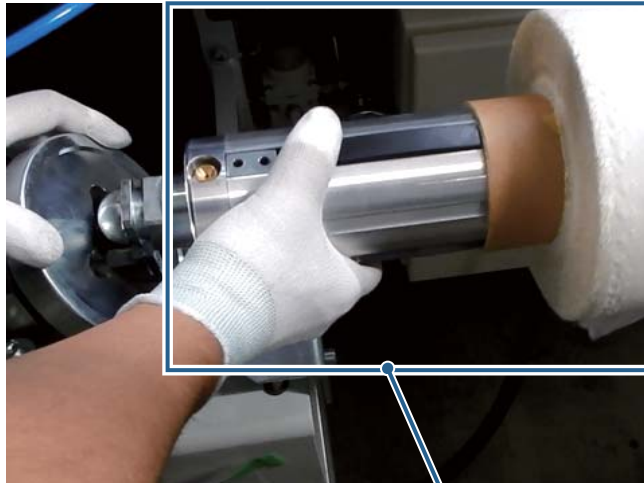

Fabric roll

- 7 Lock the feeding unit.**

**WARNING:**

Do not place your hands between the feeding spindle and the feeding unit.
Otherwise, your fingers or hands could get caught in the feeding unit and cause an injury.

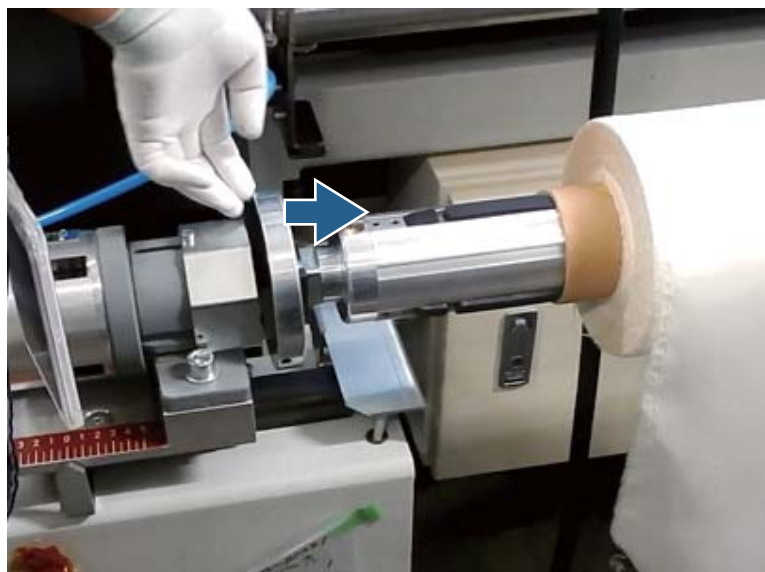

- 8** Adjust the lateral position of the fabric. Align the center of the fabric with the center of the printer.

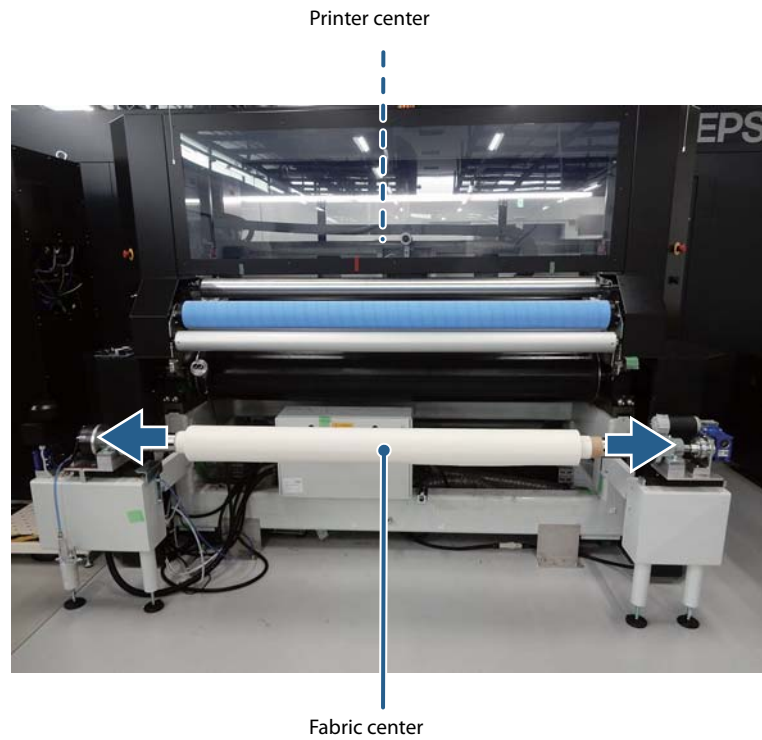

- 9** Insert the air expansion tool into the air inlet on the feeding spindle and inject air. The stopper on the feeding spindle swells to fix the fabric.

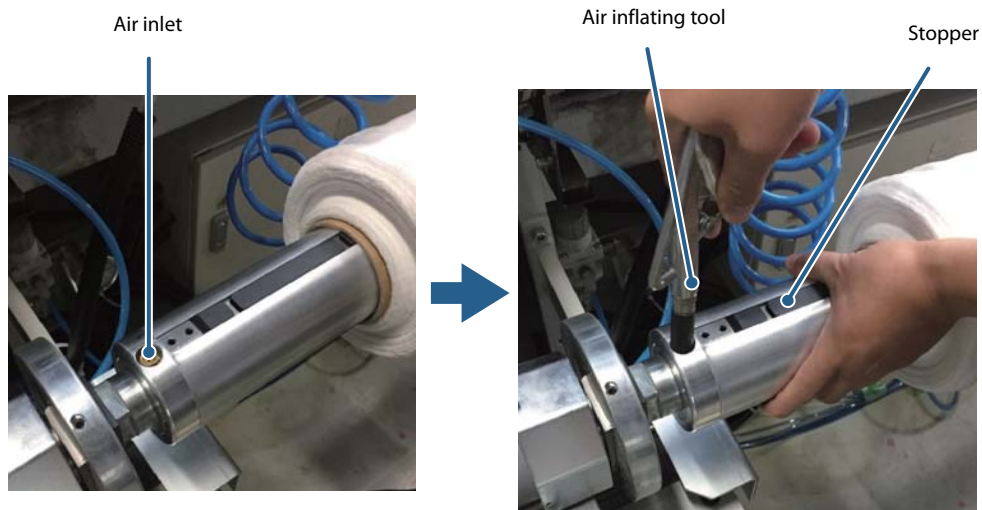

Installing Fabric on the Printer



WARNING:

- Fabric should be installed by at least 2 people.
- The fabric must be as smooth and firm as possible. If the fabric edge is fraying and threads are loose, the fiber may come into contact with the print head, damaging the print head. In the same way, be sufficiently careful to prevent protrusions and fraying at the seam between pieces of fabric.

- 1 On the screen of the control PC, select Pressure Roller Heater under [Print Settings] - [Device Settings] in the [Print] menu.**
The target temperature default value is 40.0°C.
Change it as necessary according to the environment and type of glue that is used.
- 2 Make sure that the Brake for the Tension switch on the rear panel is set to Off (Middle). If the switch is set to On (Right/Left), set it to Off (Middle).**
- 3 Move the pressure roller to the feeding side.**
Turn the Pressure Roller switch on the rear panel to the left (Up/Down) to lower the pressure roller. Then, turn it to the right (Swing) to move the pressure roller. When the pressure roller reaches the feeding side, return the switch to its original position. The pressure roller stops at the front edge.
- 4 Open the rear covers (Home/Full).**

- 5** Pass the fabric that is fed from the feeding unit through the roller on the machine. For more information about how to pass the fabric through when using an external feeding unit, refer to ["Passing the Fabric Through This Machine"](#) on page 82.

Cross-section of fabric path

Feeding unit

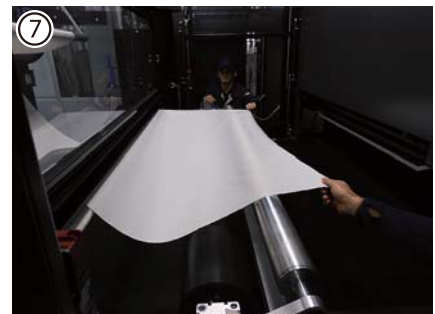
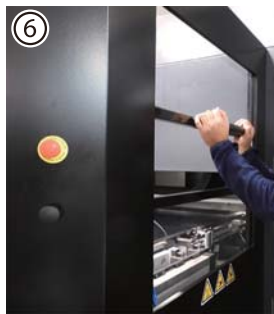
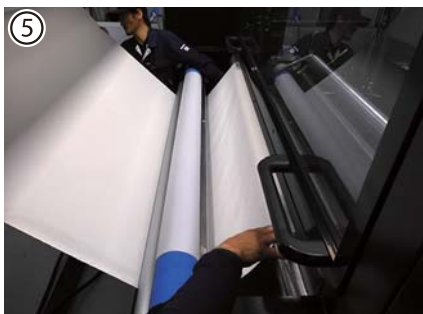
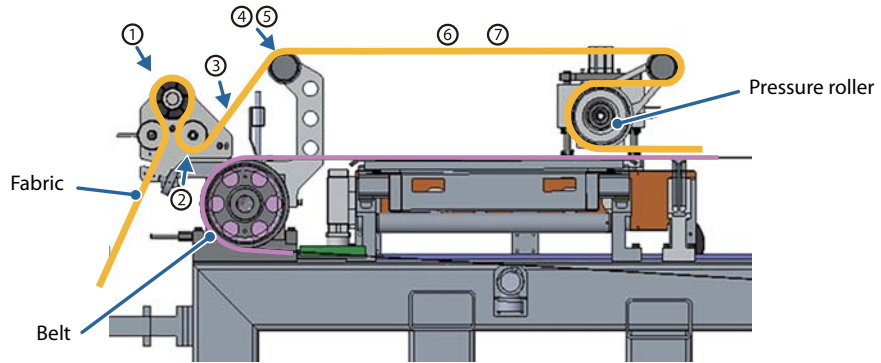

- 6 When passing the fabric through the pressure roller, use adhesive tape to temporarily fix the fabric to both sides of the pressure roller, and turn the pressure roller by hand.

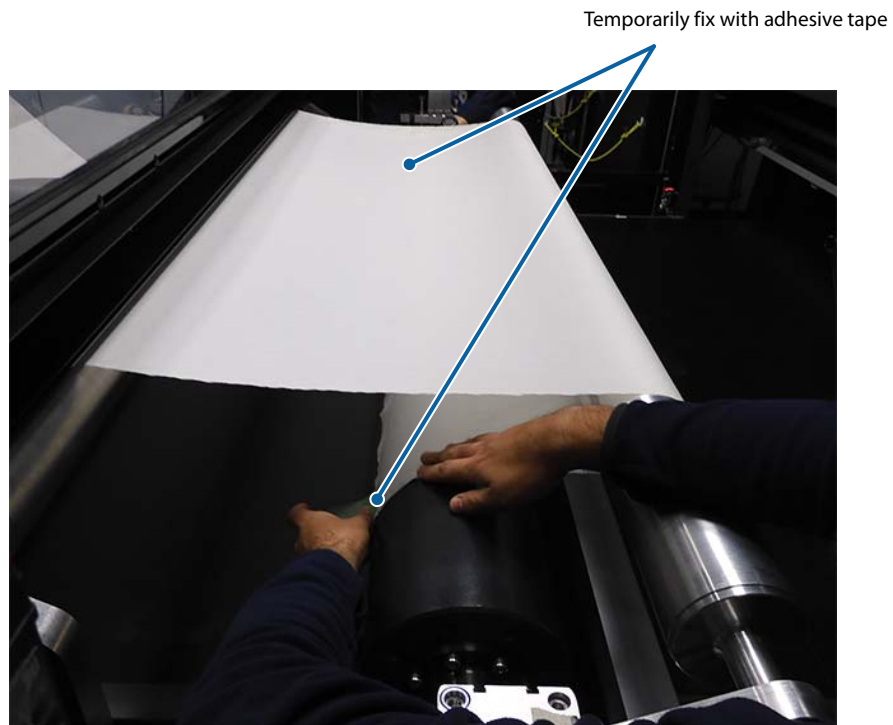
**CAUTION:**

Do not touch the roller section of the pressure roller for a long period. It could cause burns.

- 7 Once the fabric passes under the pressure roller, remove the adhesive tape.
- 8 Pull out in the reverse feed direction any fabric that extends beyond the range in which the pressure roller moves.
- 9 After you have pulled out the fabric, spread it out on top of the belt, and then press it onto the belt as far as you can reach.
- 10 Close the rear covers (Home/Full).

11 Press the feeding unit button (On) on the rear panel.

12 From the control PC, open the [Print] menu and confirm that [Print Settings] - [Device Settings] - [Cut Sheet Mode] (1) is not selected, or that [Belt Cleaning] and [Pressure Roller] (2) are selected.

If [Cut Sheet Mode] (1) is selected, unselect it.

If [Belt Cleaning] and [Pressure Roller] (2) are not selected, select [Belt Cleaning] and [Pressure Roller]. This allows you to perform belt cleaning and press on the fabric using the pressure roller while the feed button is held.

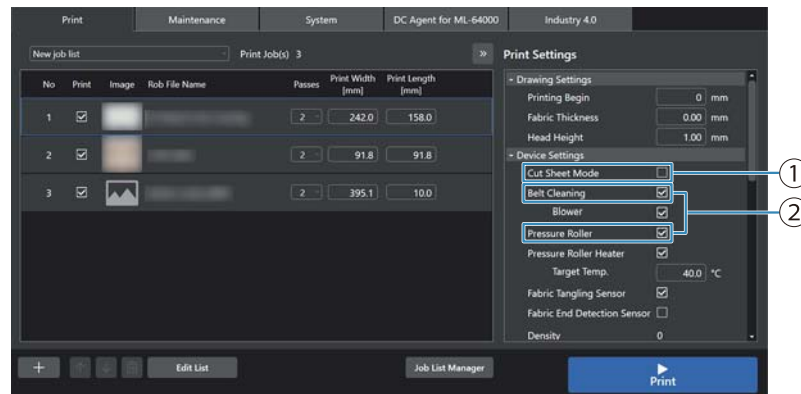

13 Press the feed button on the front panel to feed the fabric to the front, at the position indicated in the figure.

While the feed button is held, the belt is cleaned and the fabric is pressed using the pressure roller.



WARNING:

Do not place your hand or fingers between the pressure roller and belt. Your hand or fingers could be pinched, causing injury.

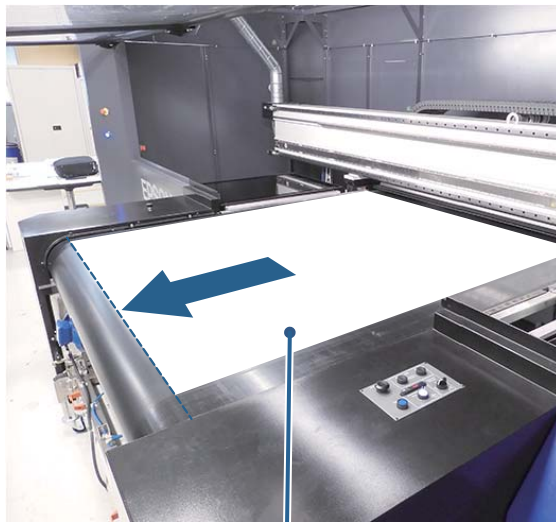

Fabric



If you fed the fabric too far, press the backfeed button on the front panel while using a wipe cloth to wipe away any water droplets that adhered to the belt on the front side of the machine.



14 Peel off the fabric edge from the belt.

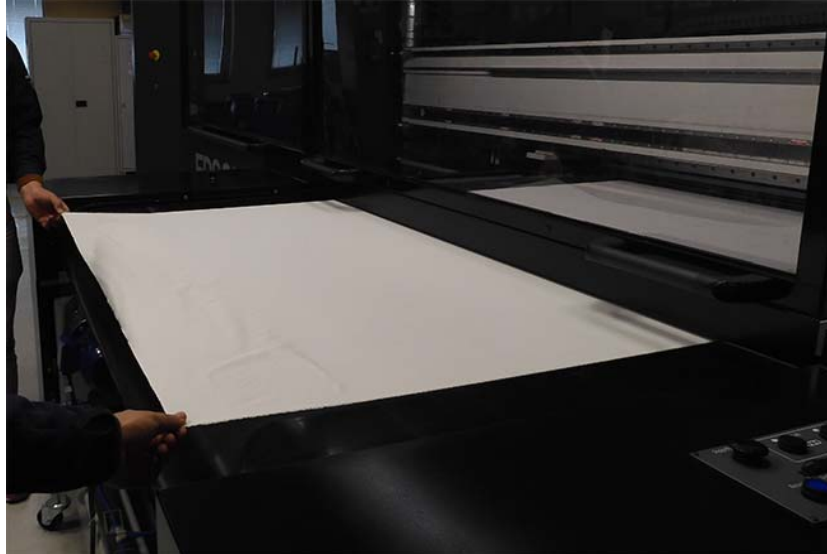

15 Worker 1: Hold the fabric edge.

Worker 2: Press the feed button on the front panel to feed the fabric by the length needed to install it on the external dryer or external winder.

While the feed button is held, the belt is cleaned and the fabric is pressed using the pressure roller.

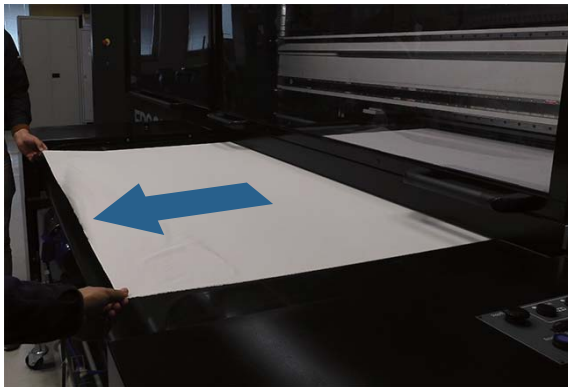

16 Install the fabric on an external dryer or external winder.

Note:

If there is enough length in the fabric edge, feed the fabric to the external unit and hold the fabric edge down with the roll core installed in advance on the external unit. (If taking up, use adhesive tape.)

This completes the procedure for installing the fabric.

Slack Mode

Printing on knitted material and other fabrics that stretch and shrink can cause the fabric to be pulled and stretched. Use slack mode when printing on fabrics that stretch and shrink.

Note:

In the following cases, slack mode might not function correctly because the sensors fail to detect the slack part of the fabric when it sways due to moving air.

- When moving air is generated around the machine due to exhaust from peripheral devices or the passage of people
- When printing on thin fabrics

Under such conditions, put a roll core into the slack of the fabric to prevent the fabric from swaying.

Use a roll core that is heavy enough to prevent the fabric from stretching. If the roll core is too heavy, the fabric will stretch and wrinkle when printing.

1 Turn on the power in the electric box on the rear of the machine.



2 Press the feeding unit button (On) on the rear panel. The button lights up.



3 Set the Slack detection switch to On.



4 Turn the tension switch to the right to turn on the tension roller and fabric tension adjustment for the feeding unit.



5 Load a fabric roll onto the feeding unit.

For more information, refer to ["Attaching fabric to the feeding unit \(optional\)"](#) on page 59. How the fabric is passed into the machine varies depending on the height of the fabric entry path. For more information, refer to ["Passing the Fabric Through This Machine"](#) on page 82.

- 6** Turn the knobs on the tension adjustment dials (Tension Roller/Feeding Unit) to the right to unlock.



- 7** Turn the tension adjustment dials (Tension Roller/Feeding Unit) to the right to adjust the fabric tension until the spindle does not rotate under the weight of the fabric roll and the fabric can be pulled out without resistance.



8 Put the roll core into the slack of the fabric.



9 When printing on the inner side of the fabric, turn the slack adjustment switch on the feeding unit to the left. When printing on the outer side of the fabric, turn the slack adjustment switch to the right.

The spindle for the feeding device rotates and the fabric begins to slacken.

The following procedures describe how to print on the inner side of the fabric.

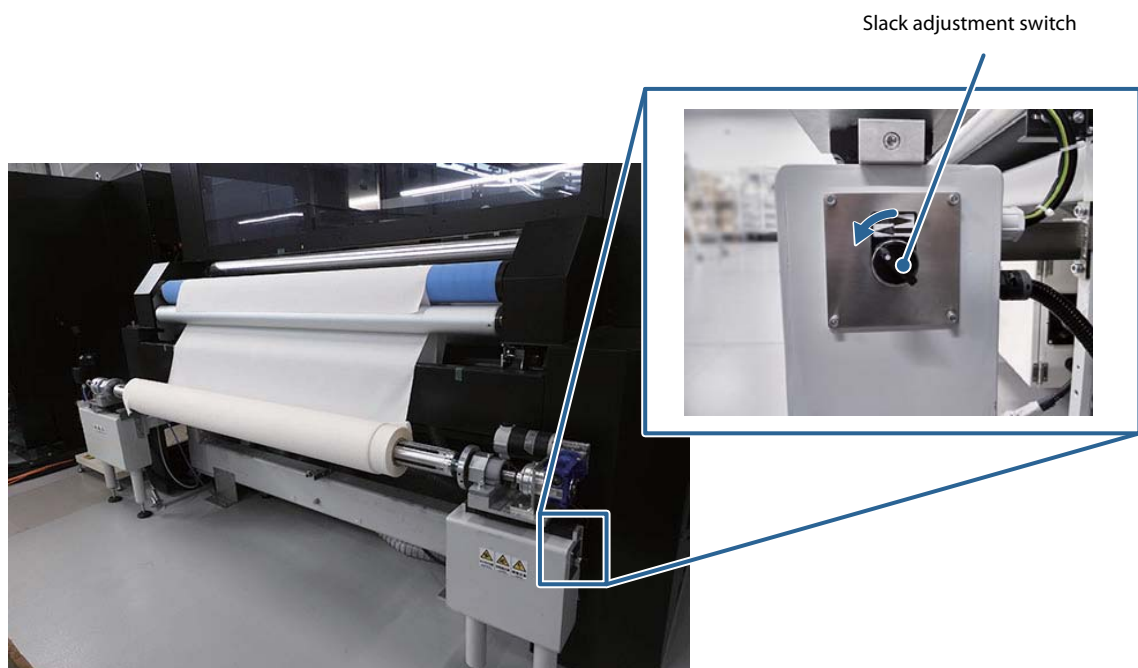

10 When the fabric hangs down to the height of the slack sensor, the machine automatically stops.

The amount of slack is detected by the slack sensor in the rear lower center. If the belt moves and lifts up the fabric so that there is not enough slack, slack is given to the fabric until the sensor detects the fabric.

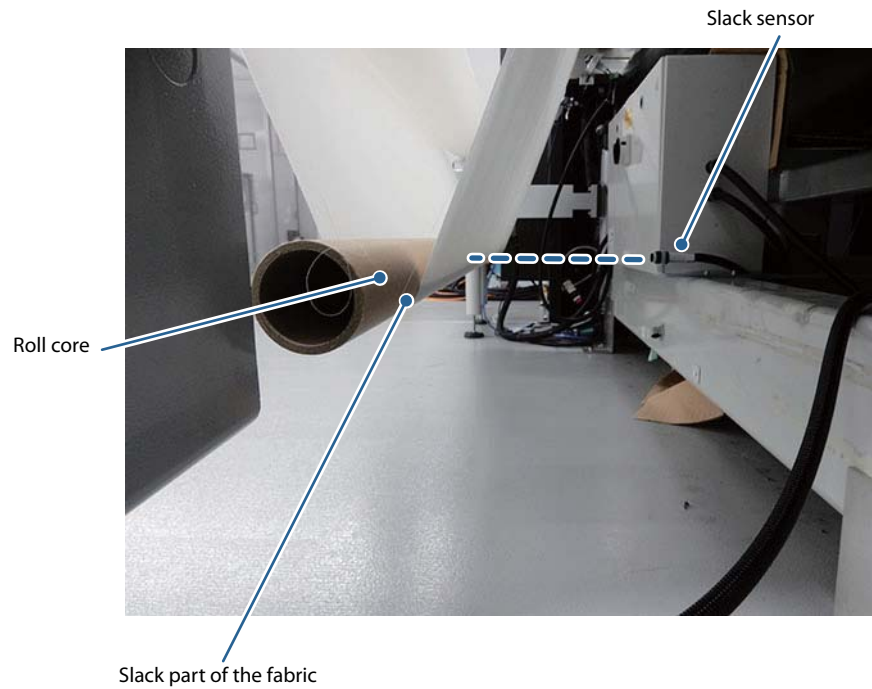

When the slack sensor does not detect the fabric

If the machine does not stop automatically even though the fabric hangs down to the height of the sensor, the sensor may be too far or too close to the fabric. If this occurs, adjust the distance between the sensor and the fabric.

- 1 Turn the slack adjustment switch to the center.

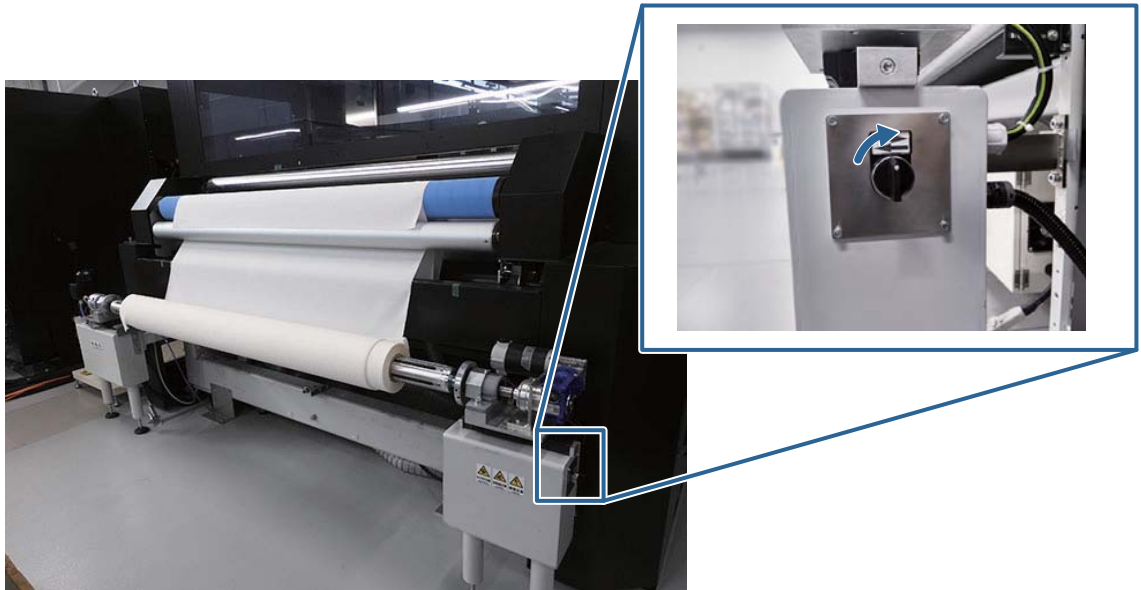

- 2 Loosen the two knob screws on the slack sensor.



- 3** Adjust the distance between the slack sensor and the fabric to between 50 and 150 mm.



- 4** Tighten the two knob screws on the slack sensor.
- 5** Turn the slack adjustment switch to the left.
The spindle for the feeding device rotates and the fabric begins to slacken.

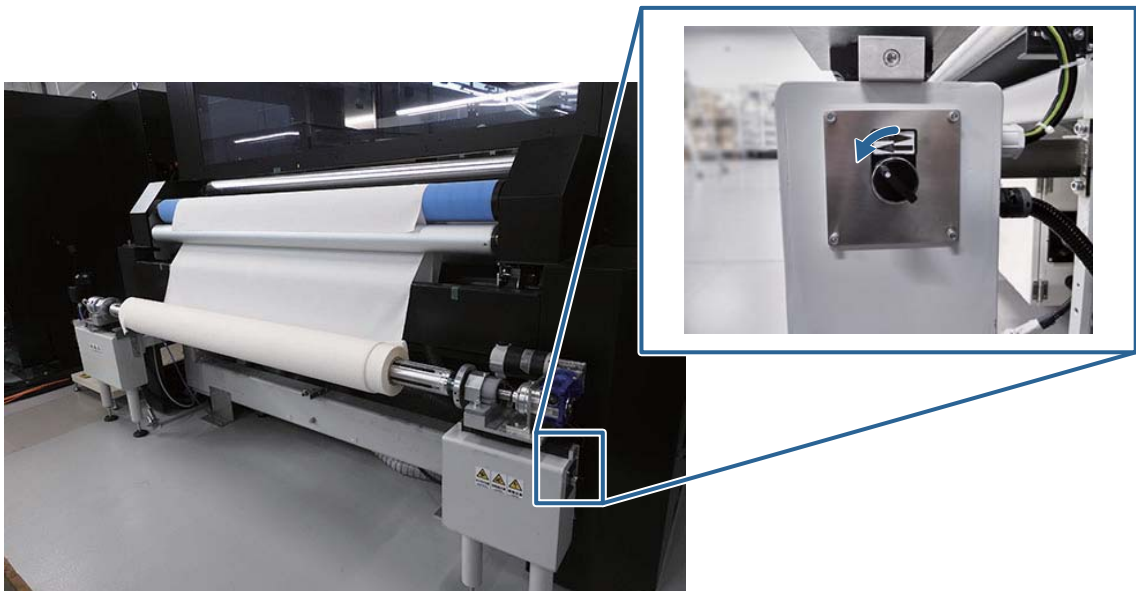

- 6** Confirm that the machine automatically stops when the fabric hangs down to the height of the slack sensor.

Fabric Drifting Correction

If you load a fabric roll with uneven edges, the fabric will drift. Either wind the fabric again or follow the procedures below. If the unevenness for edges of the fabric is severe, wind the fabric again.

- 1 Turn on the power in the electric box on the rear of the machine.

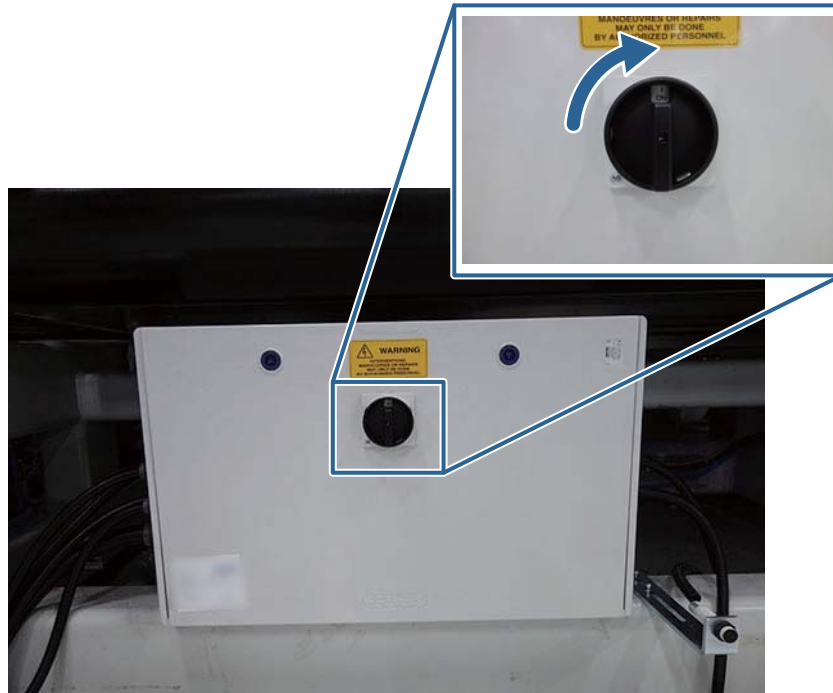

- 2 Press the feeding unit button (On).
The button lights up.



- 3 Turn the fabric position adjustment switch (Auto) on the rear panel to Man.



- 4** Use the fabric position adjustment switch (LR) to set the memory of the feeding unit to 0.

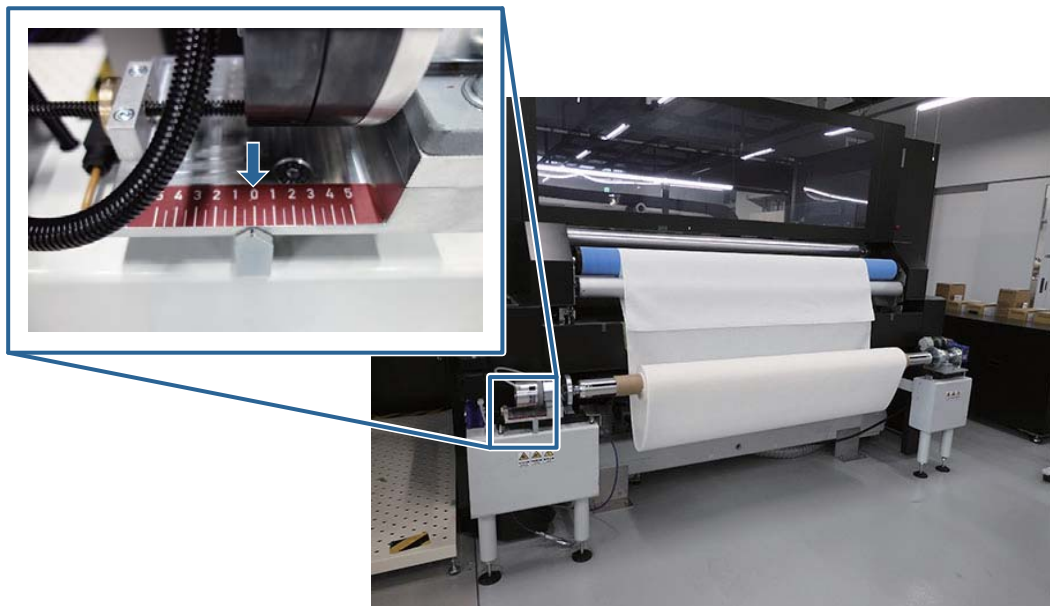

5 Adjust the position of the fabric edge sensor unit so that the left edge of the fabric is centered between the two sensors.

Loosen the knob screw to move the fabric edge sensor unit to the left or right. Align the fabric edge sensor unit with the left edge of the fabric, and then tighten the knob screw to secure it.

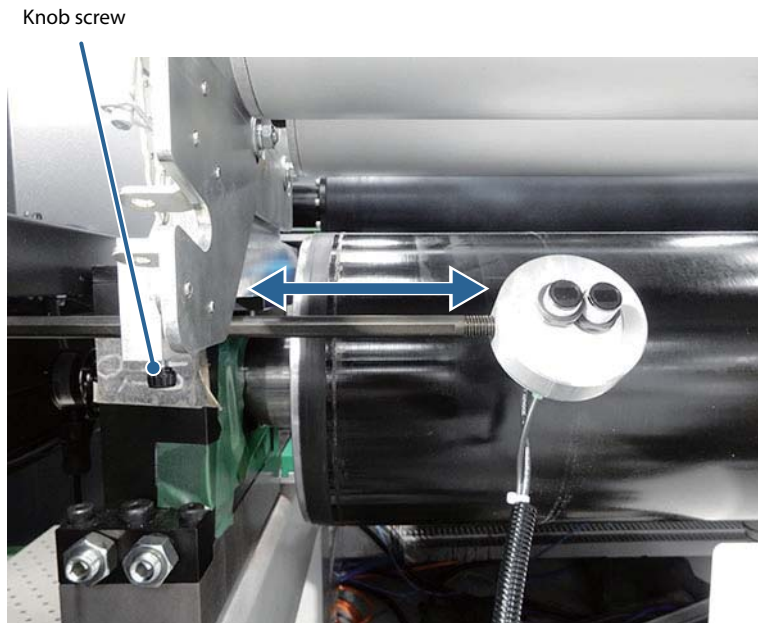

6 Turn the fabric position adjustment switch (Auto) on the rear panel to Auto. Any drifting of the fabric is automatically adjusted when printing starts.



Precise correction of drifting fabric

Use the following procedures to more precisely correct drifting fabric.

- 1 Use a hex wrench (2.5 mm) to loosen the sensor adjustment screw.



2 Rotate the fabric edge sensors to the right to make the detection range narrower.

Note:

Do not rotate the sensors more than 90° to the right. Otherwise, the sensors will be switched left to right, and it will not be possible to correct meandering.

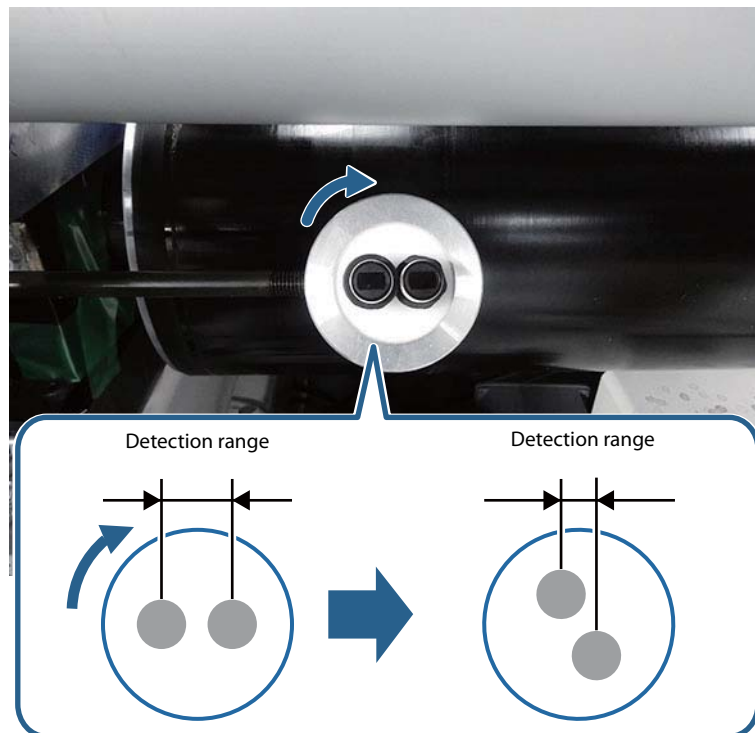

- 3 Use a hex wrench (2.5 mm) to tighten the sensor adjustment screw.
- 4 To return the sensors to the original detection range, rotate the fabric edge detection sensors to the left.

Note:

Do not rotate the sensors to the right. Otherwise, the sensors will be switched left to right, and it will not be possible to correct meandering.

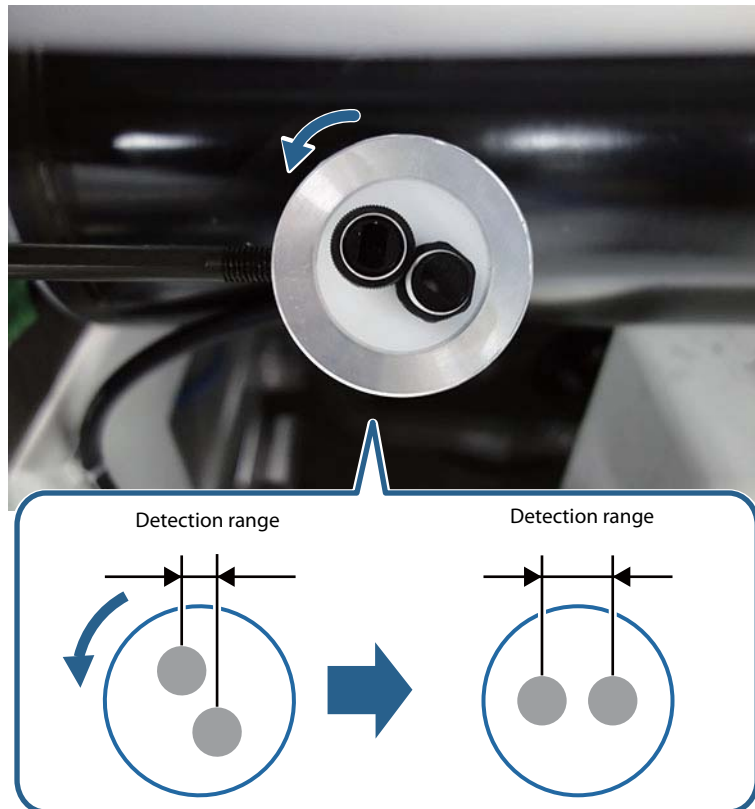

Passing the Fabric Through This Machine

The method for setting the fabric varies depending on whether you apply tension to the fabric for printing, or do not apply tension to a fabric with elasticity for printing.

When applying tension to the fabric (path for standard fabrics)

Pass the fabric through so that it wraps around the tension roller, as shown in the figure. When doing so, be sure to pass the fabric between roller 1 and the tension roller, and between roller 2 and the tension roller.

Cross-section of fabric path

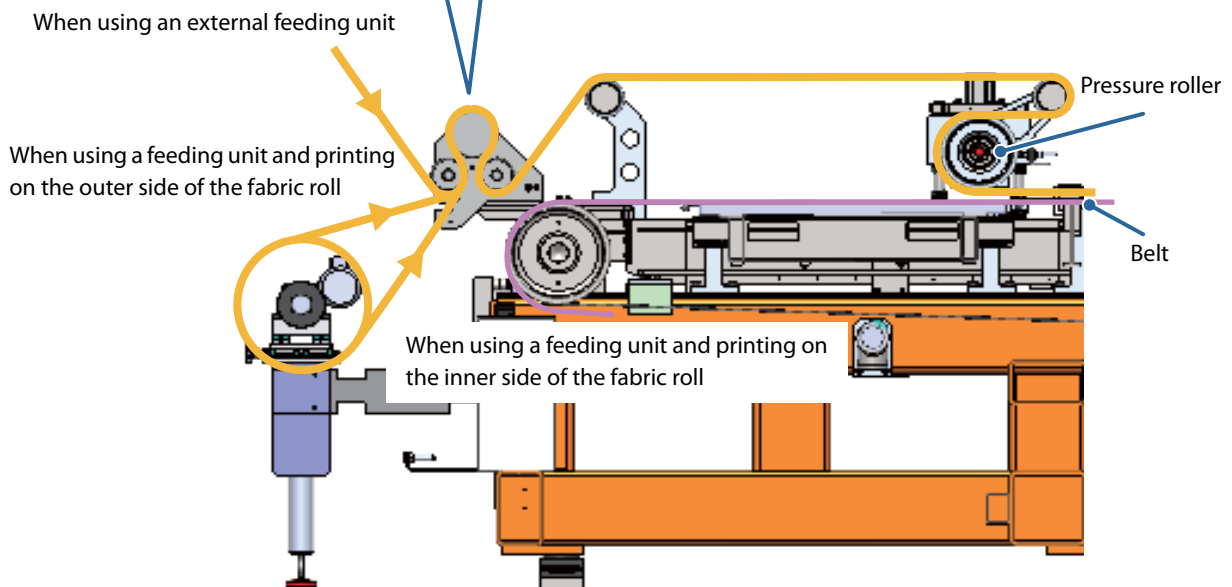
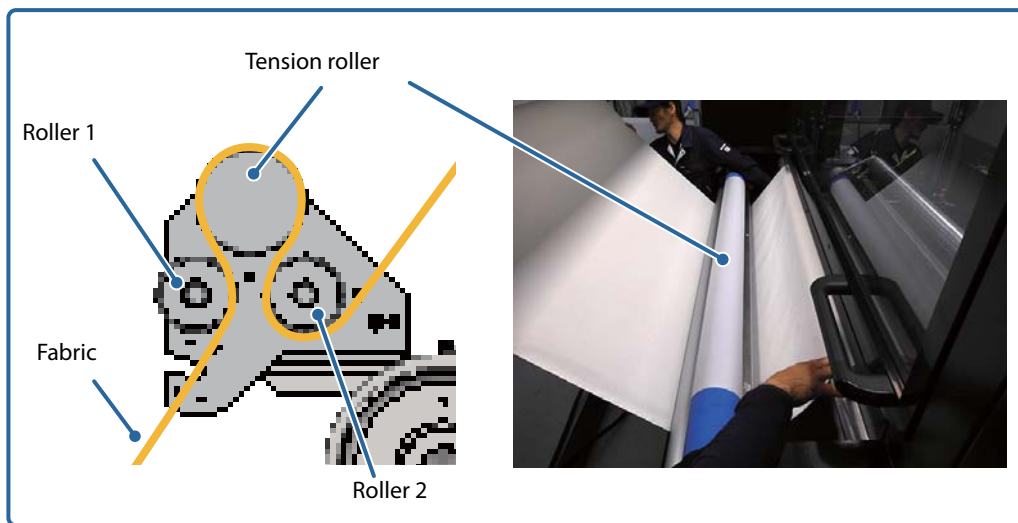

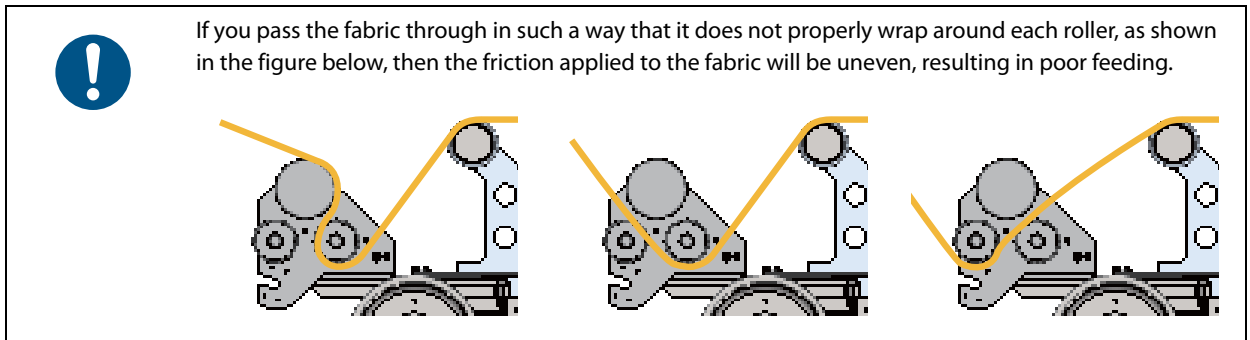

When not applying tension to the fabric (path for fabrics with elasticity)

Feed the fabric through without using a tension roller. How the fabric is passed into the machine varies depending on the height of the fabric entry path.

Cross-section of fabric path

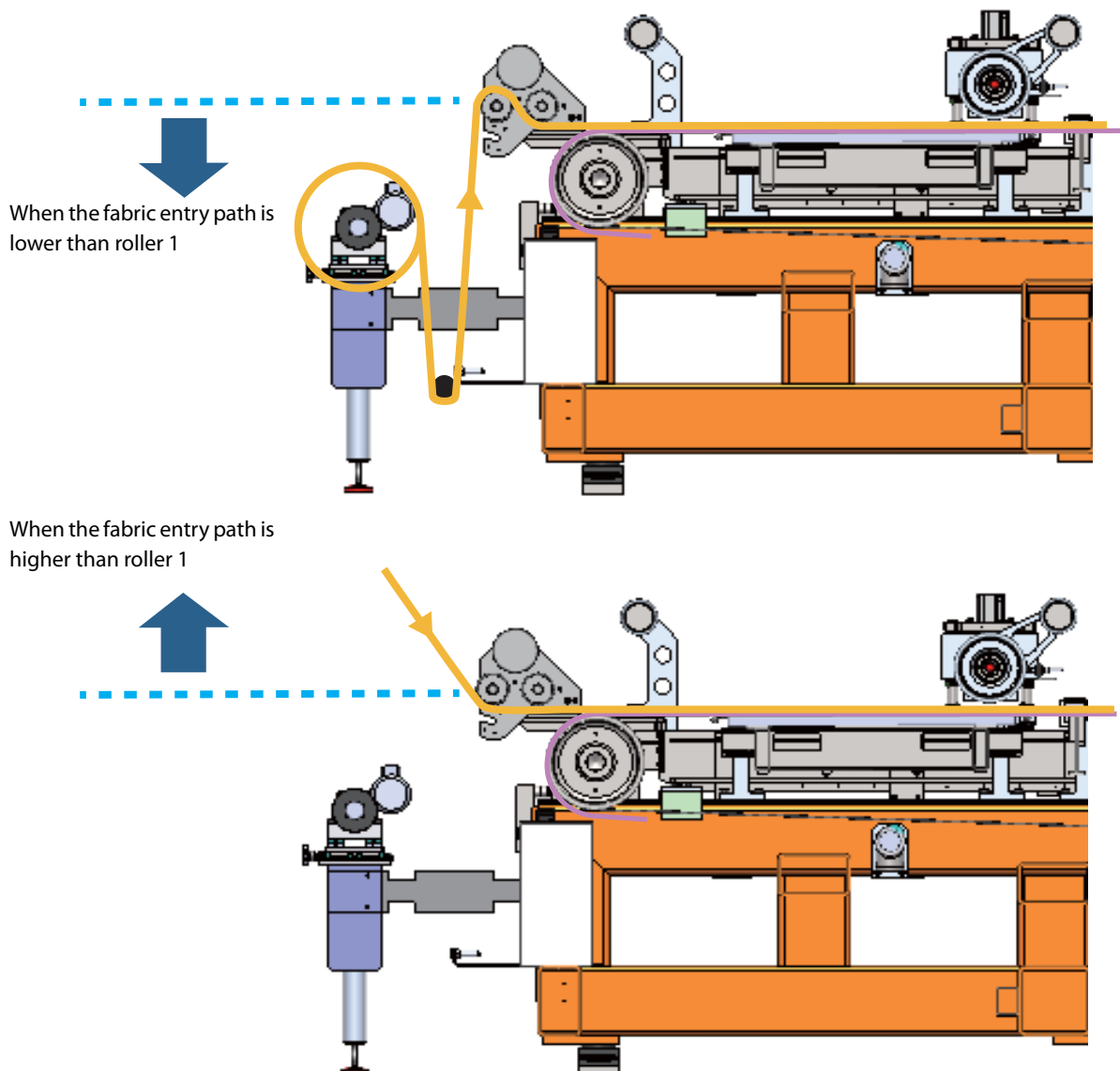

Setting the Printer

Setting the Foreign Material Detection Sensor

Set the foreign material detection sensor. When loading the fabric for the first time or changing the fabric thickness, you need to set the sensor. This sensor prevents the print heads from colliding with foreign material on the fabric, or areas where the fabric has been lifted up.

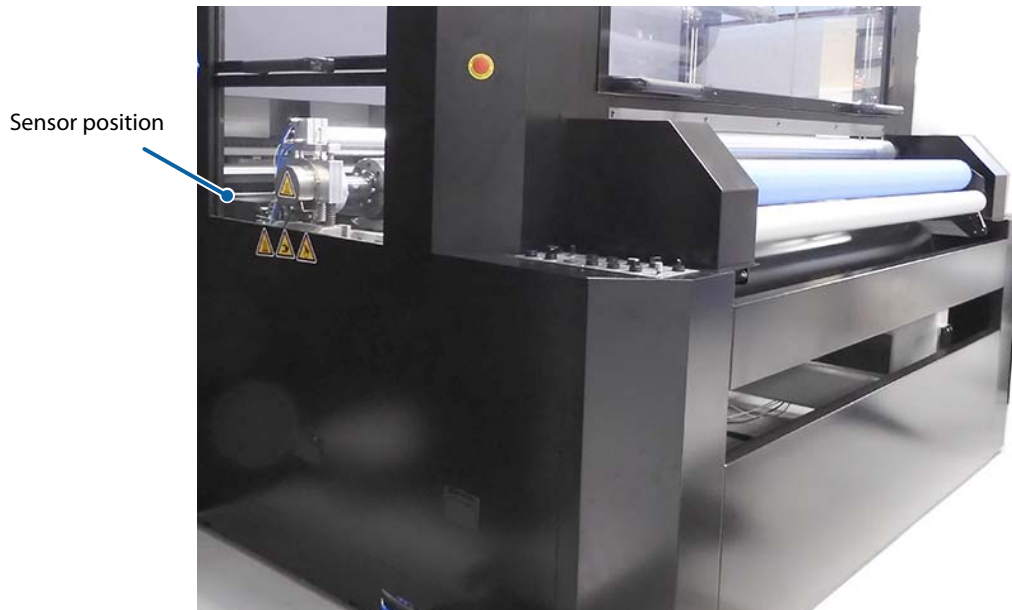

Set the foreign material detection sensor controller on the front panel on the front of the machine.

- 1 Open the cover on the foreign material detection sensor controller.



2 Set the threshold value.

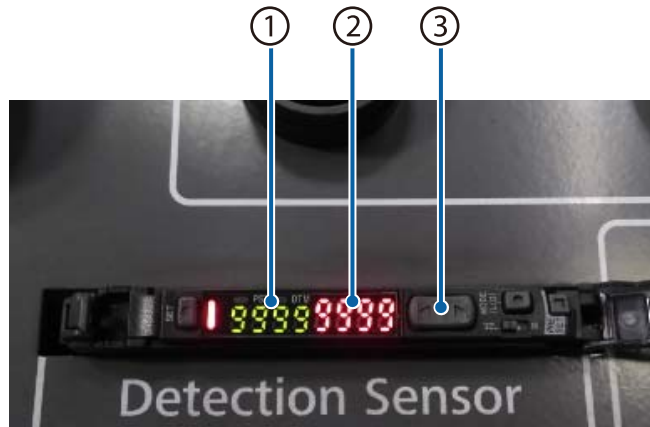

No.	Name	Description
1	Green	This is the setting for the counter's threshold value. If detected value falls below this number, an error occurs and printing stops.
2	Red	Displays the height of the fabric, measured with a counter laser.
3	Selector	Use the selector to set the height. Press + to increase the value for the green counter, and press - to decrease the value.

Note:

Recommended setting: Set a value that is 2000 less than the red counter.

Setting example: If the red counter is set to 9999, set the green counter to 7999.

3 After setting up, close the cover on the foreign material detection sensor controller.

Setting the Fabric Thickness and Print Head Height

Set the fabric thickness and print head height according to the fabric that is used.

These settings are very important. Since print heads discharge ink while moving left and right, vertical lines might become misaligned or blurred if the distance from the print heads to the fabric is not set correctly. In addition, if the height of the print heads is too low, the print heads could collide with the fabric. This could damage, soil, and/or cause fluffy material to adhere the print heads, causing nozzles to not be engaged.

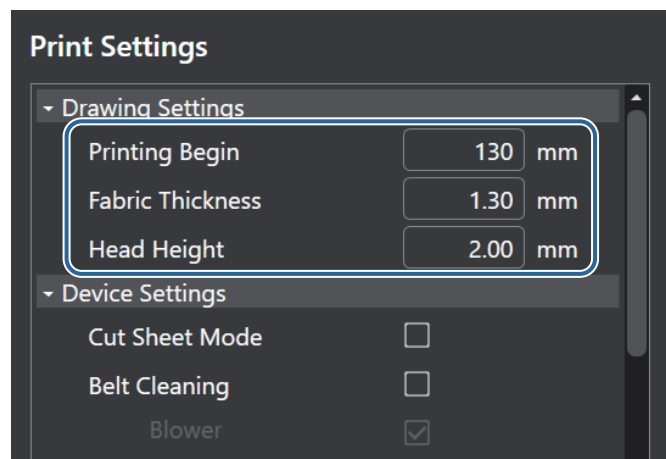
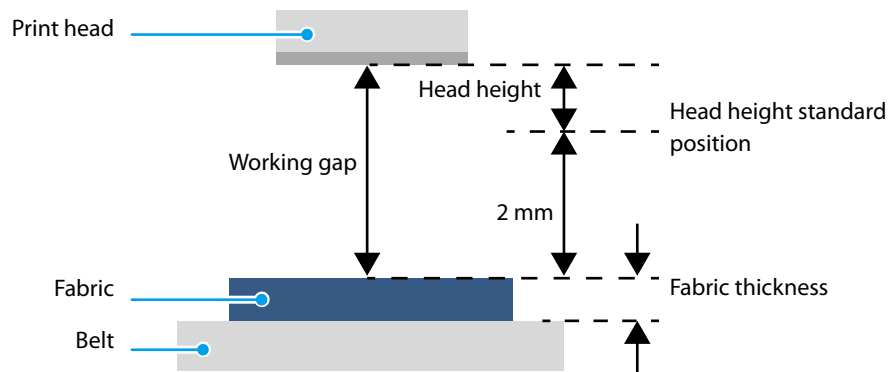

Fabric thickness: Set the fabric thickness. If the fabric does not have a consistent height, such as for shaggy fabric, enter the average value.

Head height: Set the print head height.

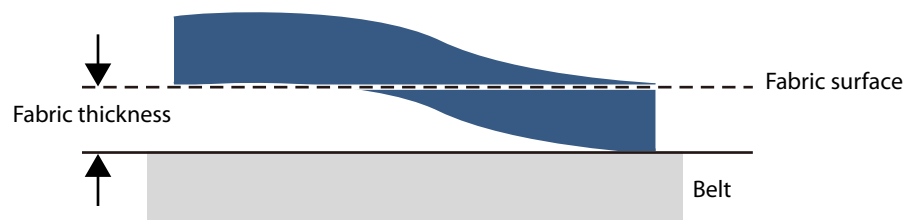

Setting the Print Data

Loading a Job

Note:

- When loading print data, only ROB files on an external USB storage device or in a shared folder can be imported. USB storage devices with a password function cannot be used. For the shared folder, enter your user name and password.
- To remove the USB memory from the control PC, perform the correct Windows operation to safely remove hardware.
- The resolution of print data is set in the application where the print data is created, and cannot be set on this machine. The number of passes can be set on this machine to adjust print quality and productivity.

- 1 In the [Print] menu on the control PC, press [+].

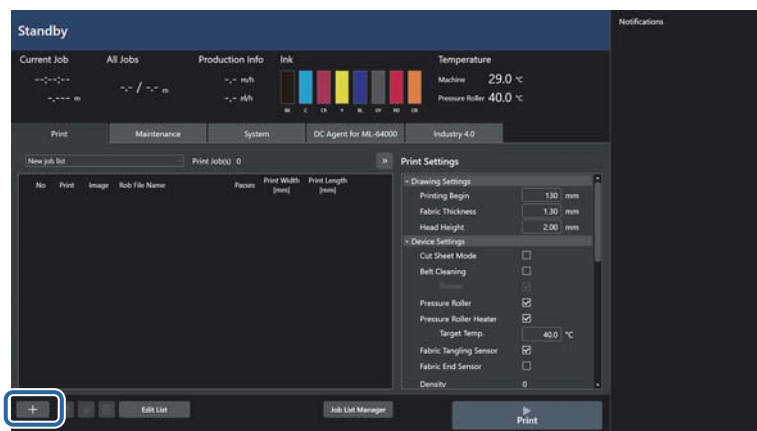

- 2 The [Add Job] screen is displayed. Press [Import] to display the Import Rob Files screen.

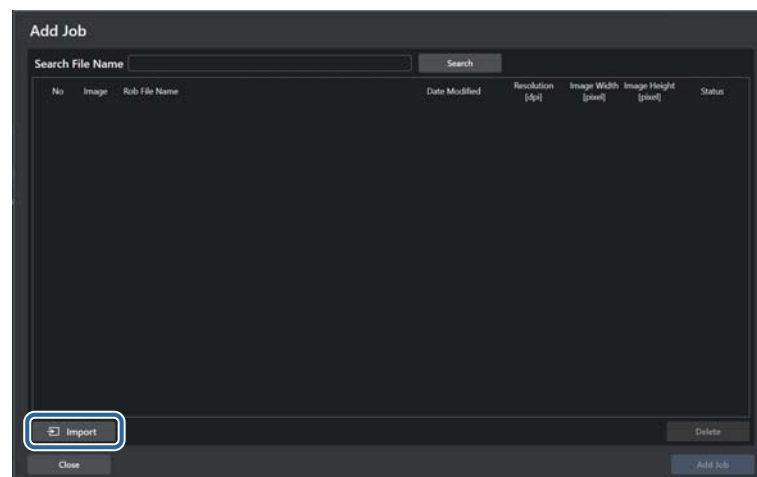

3 From the "Import Rob Files" screen, select the print data (ROB file) and press [Import].

When a file is imported, the status of the file changes.

The types of file status are as follows.

- Exists: A file with the same name has already been loaded into the machine.
- Used: A file with the same name is being used in the Job List.

The file will be overwritten if a file with the same name (file status is Exists or Used) is present on the machine side.

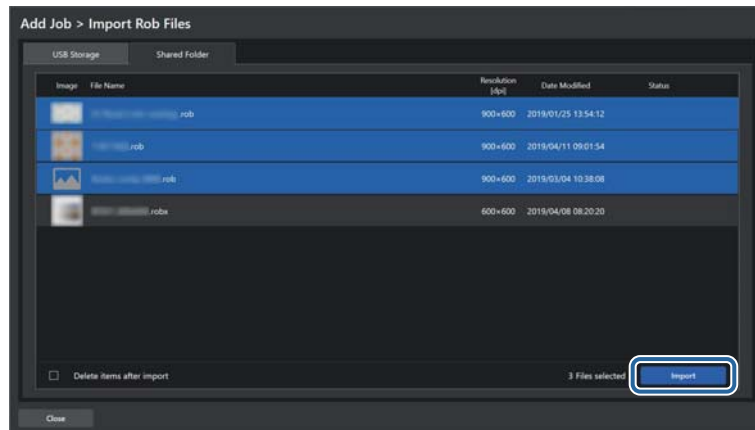

Note:

If you want to import Rob files over a network, copy the Rob files to the "MonnalisaPC\Rob Files" folder on your computer.

- 4 When importing is complete, the control PC returns to the "Add Job" screen. Select the ROB file you want to add, and then press [Add Job].

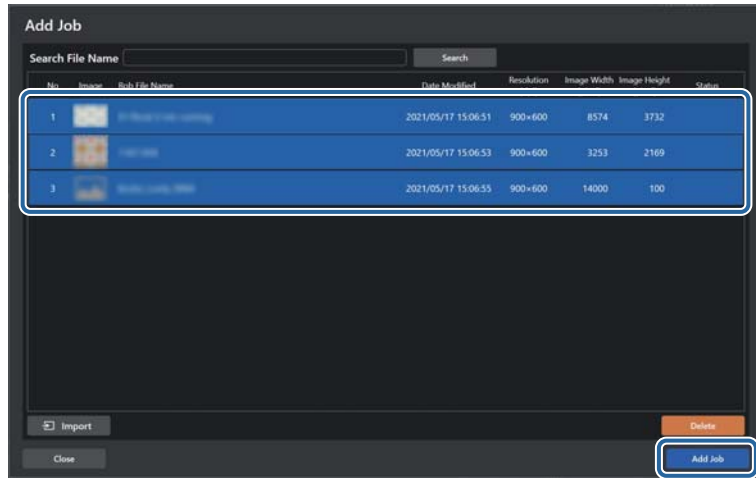

The selected ROB file is added to the JOB list.

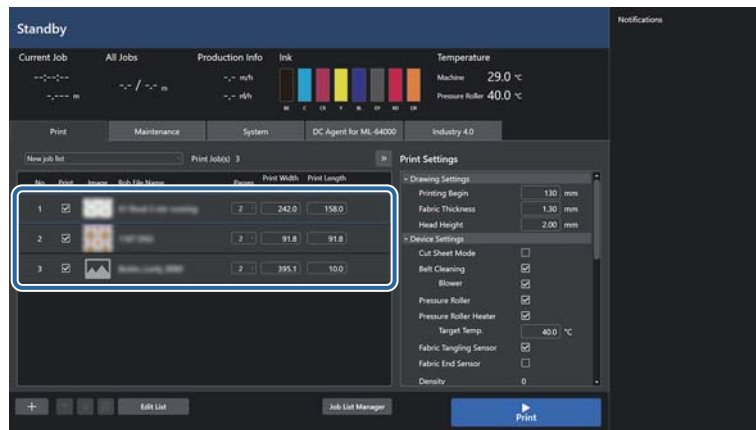

Displaying the JOB Details Screen

In the [Print] menu, press [>>] to display the job details screen.

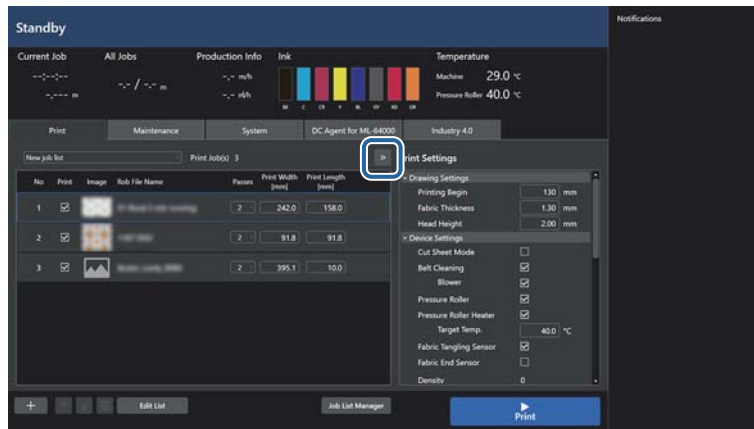

Editing the Job List

When you create a job list, you can change the job print order and delete jobs.

1 Click the [Edit List] button on the [Print] tab.

↑ ↓ 🗑 The button is enabled.

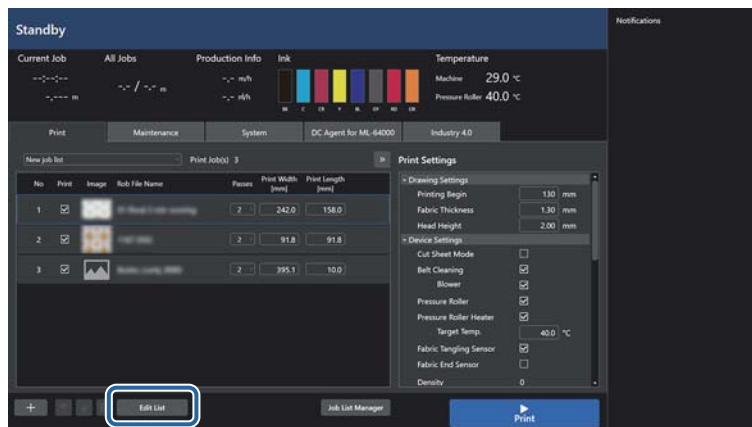

2 Click the Rob files you want to edit to select them, and then use the buttons below to edit the job list.

↑ : Move up the printing order.

↓ : Move down the printing order.

🗑 : Delete from the job list.

- 3** Click the [Done] button to return to the [Print] tab.
The button is disabled.



Creating a New Job List

- 1** Click the [Job List Manager] button on the [Print] tab.
The Job List Manager is displayed.

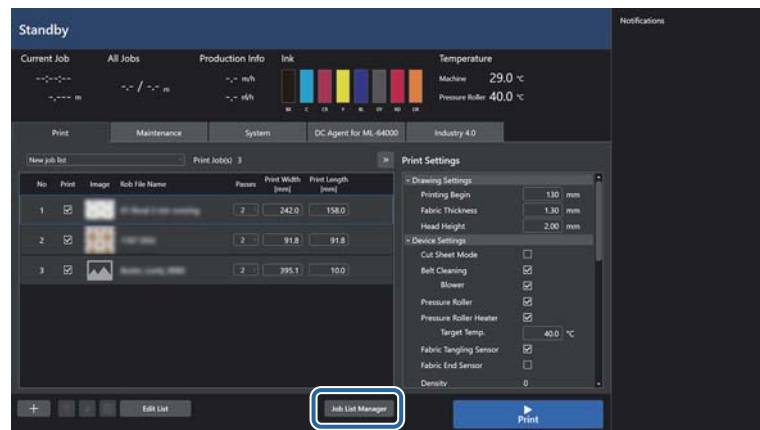

- 2** Click the [Create New] button.

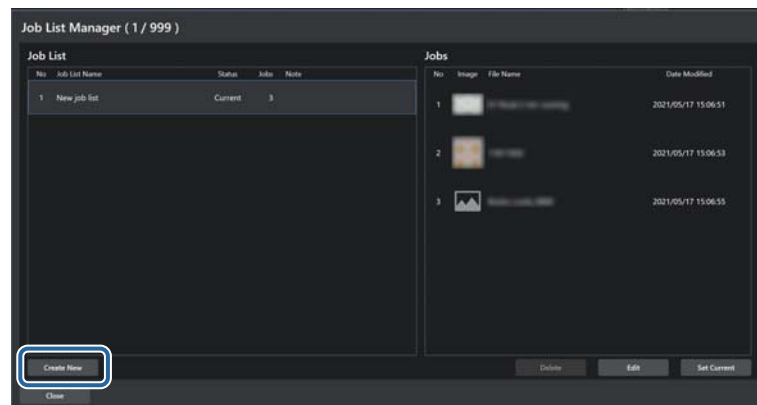

3 Enter the name of the new job list, and use the [Add Job] button to add the Rob file to the job list.

Rob files can be loaded from data retained in an application or from local folders or shared folders. For more information, refer to "Loading a Job" on page 87.

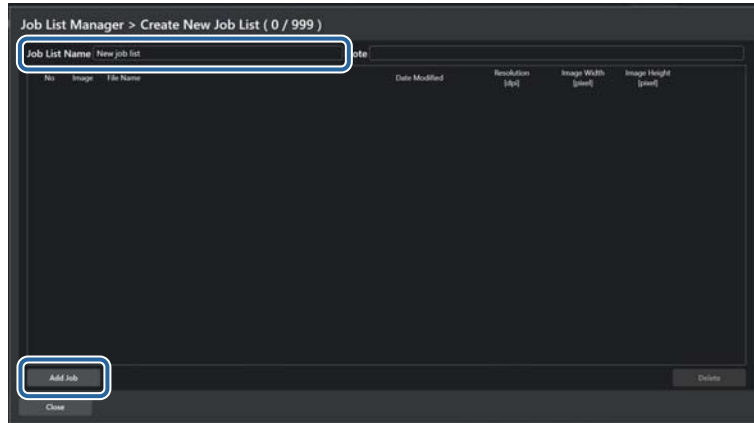

4 Click the [Close] button. The Job List Manager is displayed.

Newly created job lists can be used as described below.

- From the Job List Manager screen, click to select the job list you want to use, and then click the [Set Current] button. The [Status] changes to [Current].

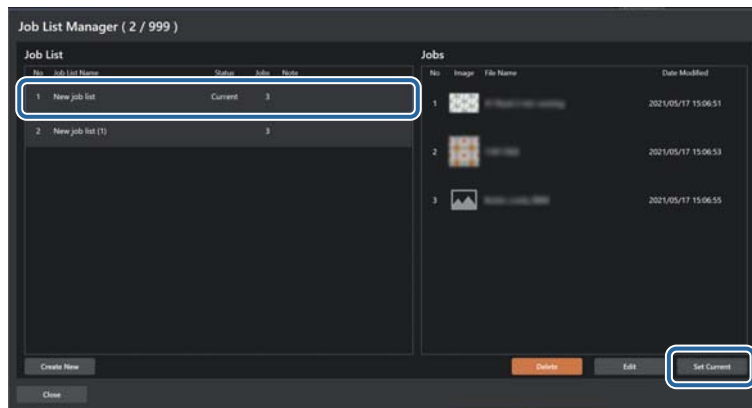

- From the [Print] tab's pull-down menu, select the job list you want to use.

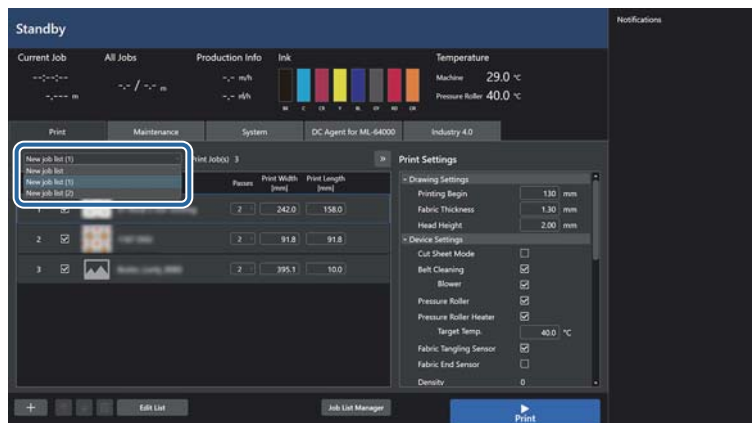

Printing

Checking the Status of the Fabric

Check the status of the fabric.

- The fabric must be pulled into the print surface and spread out flatly.
- There must not be any folds or protrusions and the fabric must not be lifted up.
- If there is a seam between pieces of fabric, take measures to make it flat so that it does not scrape against the print head.

Checking the Print Path

Check the print path.

- No foreign material in the print head operating area.
- There must not be any abnormalities in the fabric path or winding path.

Printing

1 Confirm that one or more job files are registered in the [Print] menu.

You can consider the print quality and productivity for each file when setting the number of passes. The number of passes determines how many times the print head moves and prints on the fabric. In general, a larger number of passes improves print quality but reduces productivity. The number of passes can be selected under Pass for each job.

2 Press [Print] to start printing.

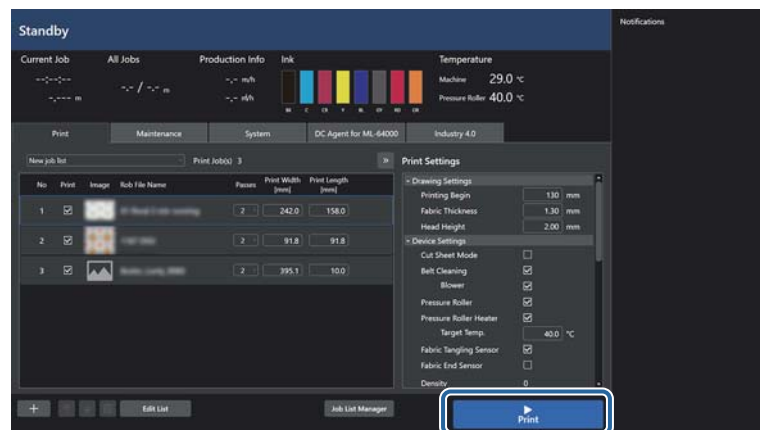

The status changes to "Preparing to Print", the signal lamp flashes green, and printing starts.

Note:

To pause printing, press [Pause]. Then, to restart printing, press [Restart].

To stop printing, press [Stop]. If there is any data that has not been printed, it will be discarded.

3 When printing is complete, "Standby" is displayed for the status, and the signal lamp turns green.

Setting the Belt Speed while Printing

If the belt speed of this machine is faster than the fabric take-up speed of the external dryer, and misalignment or other winding error occurs, adjust the belt speed on the control PC. You can make this adjustment without stopping printing. The belt speed will change as soon as the adjustment is made.

If the belt speed of this machine is slower than the fabric take-up speed, adjust the take-up speed of the external dryer or external winder. For more information about how to operate the external dryer or external winders, refer to the instruction manuals that come with them.

Making Adjustments

In the [Print] menu on the control PC, make adjustments by moving the round button above the bar in [Print Settings] - [Device Settings] - [Belt Speed] to the left or right. Belt speed can be adjusted in 5% increments.

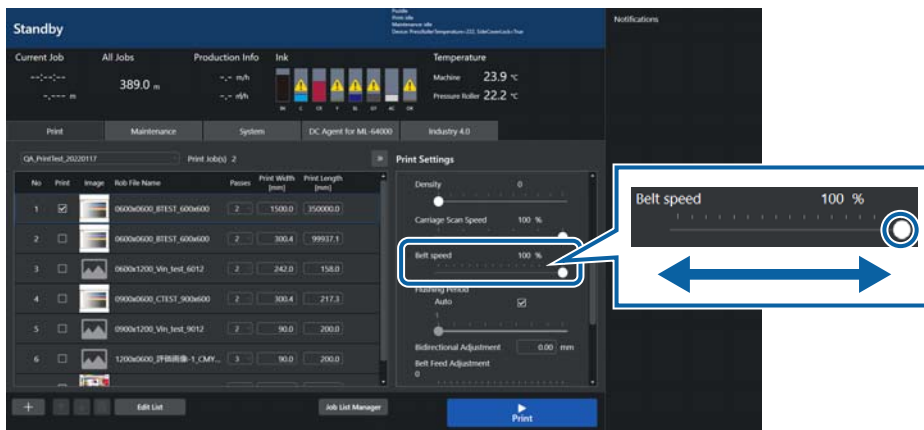

To return to normal belt speed, move the round button to the 100% position.

Replacing Ink Cartridges

Ink Cartridge Replacement Procedure

When the remaining ink level is detected to be below the threshold, the user is notified in the following ways:

- A low ink warning is displayed on the control PC screen.
- The  icon is displayed for the slot(s) where the low ink level was detected.
- A buzzer sounds.

Use the following procedure to replace ink cartridges.

- 1** Check the message on the control PC screen, and press the [Release] button.
- 2** From [Ink] on the screen, check the ink slots whose remaining ink is below the threshold value.



Note:

Replace the ink within 10 minutes after the detected level drops below the threshold value. Continuing to print without replacing the ink cartridge after the ink level is detected to be below the threshold value might cause printing to stop when the ink runs out.

- 3** Check to see if the cartridge check lamp is red for any ink cartridge.

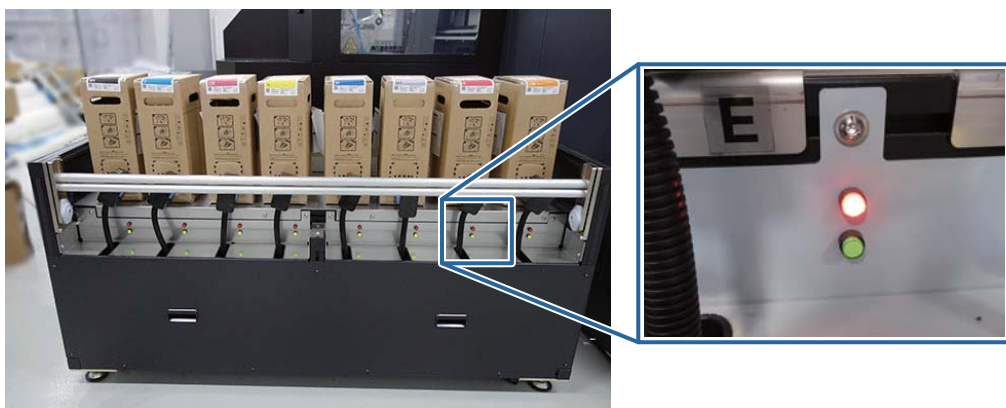

- 4** Place the ink cartridge on the floor with the ink supply port facing the side, and slide the ink cartridge back and forth longitudinally within the range of approximately 10 cm. Do 10 times for the front and back.

Move the ink cartridge at a rate of one back-and-forth cycle per second.

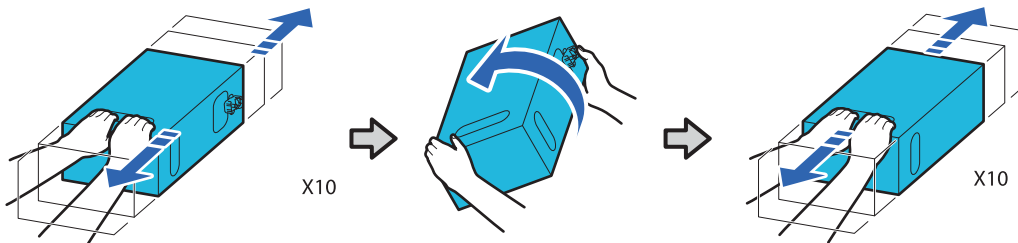

- 5** Place the ink cartridge as shown in the following image.

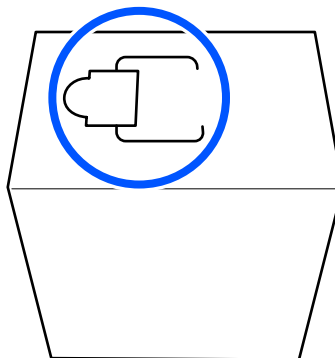

- 6** Use your hands to cut along the dashed lines of the slot to remove the top portion.

Note:

Do not use a cutter to cut along the dashed lines. Failure to observe this precaution could damage the internal parts and cause ink to leak.

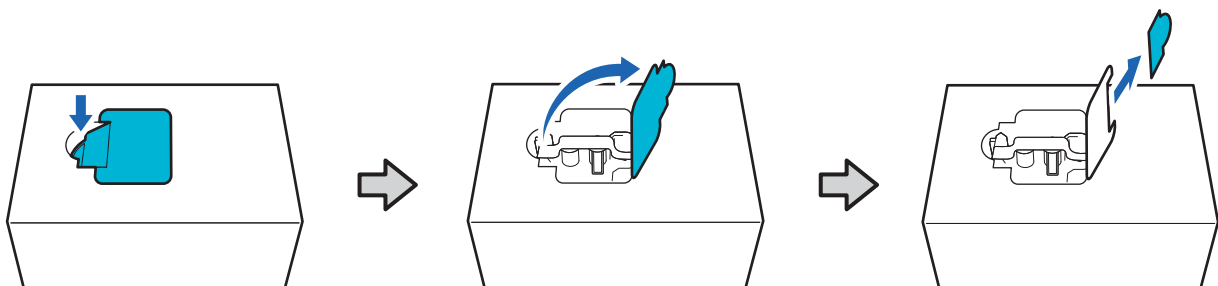

- 7** Take out the ink supply port and fix it as shown in the illustration.

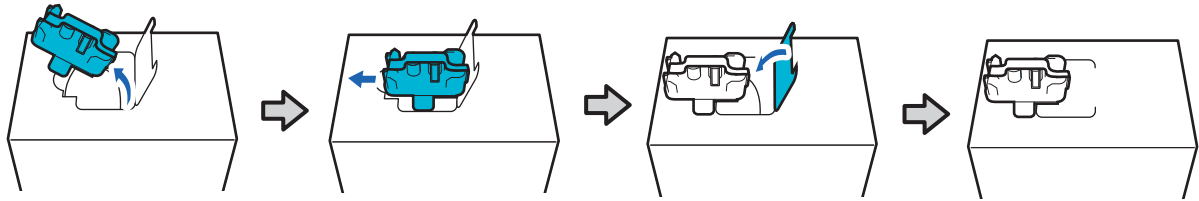

- 8** Peel the tape (yellow) from the surface of ink supply port.

Note:

Do not touch the IC chip on the ink cartridge.

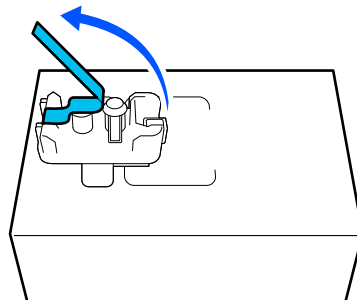

- 9** Pull the ink rack front bar towards you and down.



- 10 Disconnect the connector from the ink cartridge to be replaced. Grabbing the blue levers on both sides of the connector, pull the connector out toward you and place it on the holder.

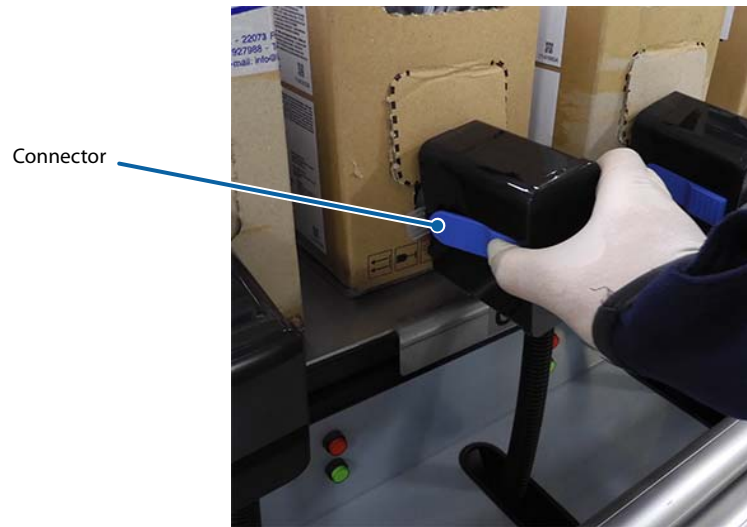

CAUTION:

Perform the following steps promptly. If you leave the connector disconnected for a long time, the ink inside the connector will dry and harden, and might block the normal supply of ink.

- 11 Lower the ink cartridge to be replaced from the ink rack. Dispose of used ink cartridges according to local laws and regulations.

Note:

If there is any ink remaining in the ink cartridge that was removed, you can use it again by reconnecting the connector and lifting the ink rack front bar.

- 12 Set the new ink cartridge in the ink rack.

Set the new ink cartridge so that it does not stick out from the ink rack.

- 13** Insert the connector into the ink supply port of the ink cartridge. Hold the connector by its body (not by the blue knob), and push it in firmly so that the needle pierces the nozzle of the ink cartridge, until you hear a "click" sound. Confirm that the blue knob is not open.

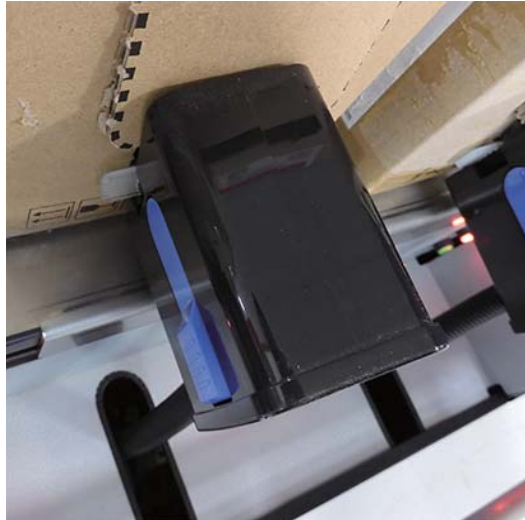

- 14** Raise the ink rack front bar up.
- 15** Confirm that the cartridge check lamp is green.



- 16** Under [Ink] on the control PC, confirm that the ink level is no longer below the threshold value for the ink slot where the ink cartridge was replaced, and that the amount of ink has increased.

This completes the ink cartridge replacement.

Workflow When Turning Off the Power

This section describes the procedure for turning off the power.

1. Cleaning ([Page 100](#))
2. Turning Off the Power ([Page 100](#))
3. Closing the Water Supply Valve ([Page 102](#))
4. Closing the Air Supply Valve of the Air Supply Regulator ([Page 102](#))

Cleaning

Refer to "Maintenance" in this manual.

Turning Off the Power

- 1 On the control PC, press the [System] menu, and then press [Shutdown] on the [Power] tab.

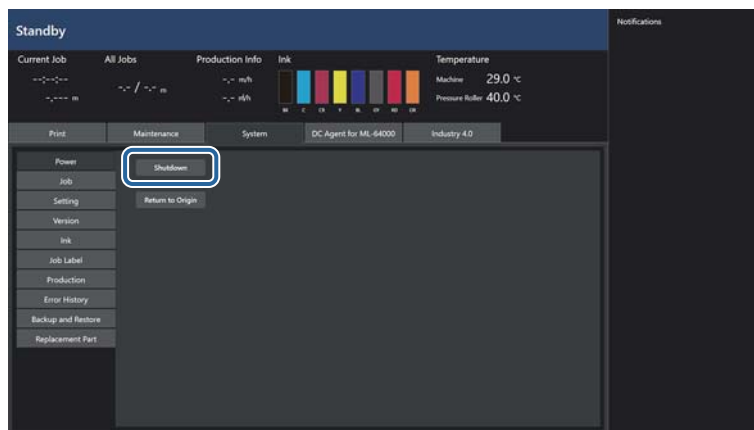

- 2 If a message is displayed, press [Shutdown].

The application on the control PC shuts down.

Windows will shut down when the application on the control PC shuts down.

3 Confirm that Windows has shut down and all signal lamps have turned off.

**CAUTION:**

If the signal lamps have not turned off within 5 minutes after Windows shuts down, press and hold the control PC's power button in the electric box. If the main power is turned off before the signal lamps turn off, control PC data may get lost or damaged.



4 Turn the main power switch on the main electric box to 0 (OFF).

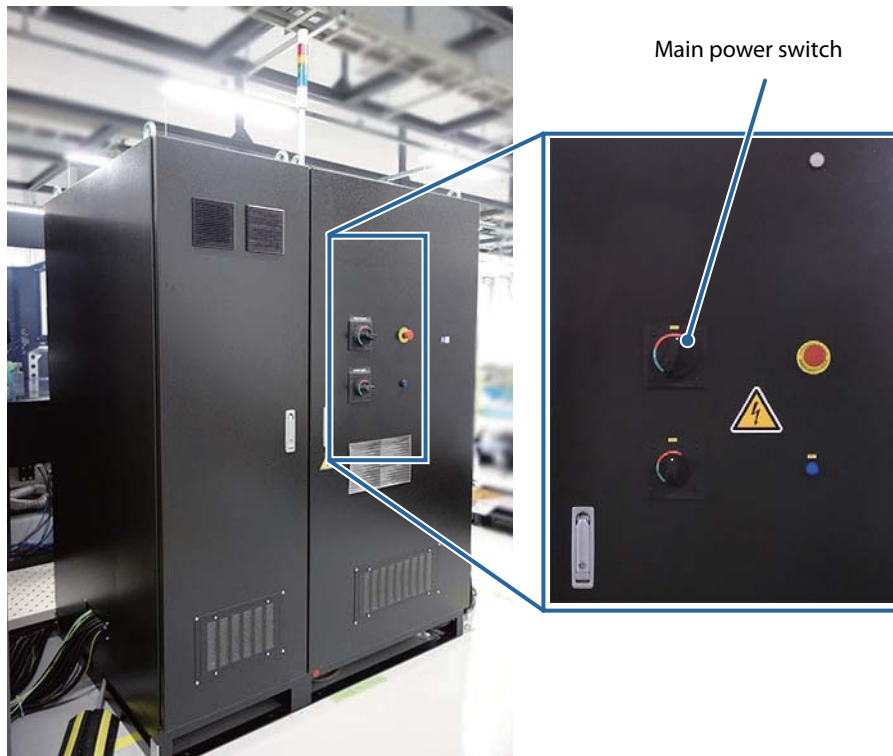

Closing the Water Supply Valve

Close the water supply valve at the bottom of the front of the machine.

Closed



Closing the Air Supply Valve of the Air Supply Regulator











Close the air supply valve of the air supply regulator at the rear of the machine.

Maintenance

Before Starting Maintenance Work









Safety Precautions

Safety Information for Maintenance Work

 WARNING		
	   	<p>Do not operate this machine or the computer while maintenance is being performed.</p> <p>When performing maintenance work in a location that is out of sight of the control PC operator, make sure that only the person performing maintenance work and no one else is able to operate the control PC.</p> <p>Doing so leads to the risk of your hand or other parts of your body becoming caught in the machine.</p>
		<p>Do not operate this machine if you have a pacemaker.</p> <p>The electromagnetic waves that are generated by this machine can affect the operation of pacemakers.</p>
		<p>This machine generates a strong magnetic field. Do not use precision equipment such as watches and mobile telephones nearby.</p> <p>Precision equipment could malfunction or become damaged by the strong magnetic field.</p>
		<p>If using glue or glue remover that contains flammable gas, explosive gas, or the like, ensure sufficient ventilation and make sure that the ignition point and explosion limit are not reached.</p>





CAUTION







    	<p>During maintenance work, wear all of the protective equipment described in the maintenance procedures in the User's Manual (eye protection, protective gloves, respiratory protection, etc.).</p> <ul style="list-style-type: none">• Use protective equipment compliant with the safety regulations.• Using additional protective equipment compliant with the safety regulations is recommended when necessary.
	<p>Do not climb on the machine while working on it. Note that the machine is not designed to support the weight and can be easily damaged.</p>
	<p>If waste ink or maintenance liquid gets on the floor, wipe it up with a wipe cloth. Failure to do so could cause an injury due to slipping and falling.</p>
	<p>Make sure that all maintenance work is performed at room temperature.</p>

Safety Information in Handling Consumables (Ink, Maintenance Liquid) and Waste Ink



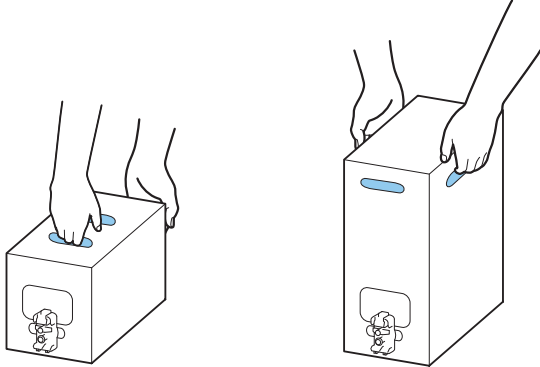



WARNING

	<p>If ink gets on your skin or enters your eyes or mouth, take the measures below.</p> <ul style="list-style-type: none">• If it gets on your skin, rinse immediately with soap and water.• If it enters your eyes, rinse immediately with water. Failure to observe this precaution could result in bloodshot eyes or mild inflammation. If problems persist, consult with a physician.• If it enters your mouth, consult a physician immediately.
	<p>Do not dismantle or remodel ink cartridges. Otherwise, fluid could get in your eyes or come in contact with your skin.</p>
	<p>Keep ink cartridges, maintenance liquid, cleaning liquid, scan spindle grease, waste ink, and glue out of the reach of children.</p>

 CAUTION	
	<div style="display: flex; align-items: center;">  <p>When lifting up an ink cartridge, wear safety shoes and place your hands in the positions indicated in the figure below. Lifting with placing the hands on other positions could cause the ink cartridge to fall or pinch your fingers when you lower it, resulting in injury.</p> </div> <div style="text-align: center; margin-top: 20px;">  </div>
 	<p>Be sure to wear eye protection, protective face mask, and respiratory protection when applying glue.</p> <p>For details, refer to the instructions of the SDS for the glue and glue remover you are actually using.</p>
	<p>Be sure to wear protective gloves when using maintenance liquid.</p>









Safety Precautions

	<p>When maintenance work is completed, immediately return the protective equipment to its original location.</p>
	<p>Make sure that no tools or parts used in maintenance work or other foreign materials are left on the operating parts of the machine or inside the machine.</p>
	<p>During maintenance, do not use sharpening stones, abrasive/corrosive materials, or solvents (excluding glue). Doing so may erase numbers, codes, or characters indicated on the machine.</p>
	<p>Do not expose the electrical and electronic devices and motors to liquid.</p>
	<p>Do not touch the interlocks on the front covers, maintenance cover, side doors unlock button, or rear covers. Doing so could cause malfunctions or damage.</p>



Use the products properly according to the "Safety Data Sheet" for each product.

Wearing of Personal Protective Equipment

 CAUTION		
	   	<p>Be sure to wear personal protective equipment (protective gloves, protective clothing, and safety shoes) during maintenance work on this machine.</p> <p>Long hair should be tied back and worn under a hair net.</p> <p>Otherwise, your hands and clothing could become stained with ink, and your fingers and hair could become caught in the machine, causing injury.</p>
		<p>Be sure to wear eye protection during maintenance work on areas near the ink path, such as when cleaning print heads, caps, and wipers.</p> <p>Failure to do so could cause ink to splash into the eyes.</p>
	 	<p>Be sure to wear eye protection and respiratory protection when applying glue.</p> <p>For details, refer to the instructions of the SDS for the glue and glue remover you are actually using.</p>

Machine Status During Maintenance Work

To ensure that maintenance work is done safely, confirm that the machine is in the indicated status for step 1 of each procedure.

The following explains each status and the procedure to put the machine in that status.

Power Off/Air Pressure Release Status

The machine's main power switch is at 0 (OFF) and the air pressure has been released.

Work which involves handling the machine's operating parts is performed in this status.

If the machine's power is on or air pressure is being applied, implement the following procedure.

- 1** On the screen of the control PC, press the [System] menu, and then press [Shutdown] on the [Power] tab.
- 2** If a message is displayed, press [Shutdown].

- 3** When all of the signal lamps go off, turn the main power switch on the main electric box to 0 (OFF) to turn off the power.



When performing maintenance after finishing a day's printing work, refer to "[Workflow When Turning Off the Power](#)" on page 100.

- 4** Close the air supply valve of the air supply regulator at the rear of the machine.

Standby Status

In this status, the machine has finished printing and returned to the origin.

[Standby] is displayed for the status on the screen.

Checks Before Maintenance Work

Be sure to check the following before moving the print heads.

- Check the area around operating parts.
Refer to "[Checking Operating Parts](#)" on page 109 for the procedure.
- Confirm that all covers on the machine are closed.
Front: Front covers (Home/Center/Full), maintenance cover, side doors (Home/Full)
Rear: Rear covers (Home/Full)
- Release all emergency stop buttons for this machine and any linked devices (if they have been pressed).

Checking Operating Parts

Do not place tools, fasteners, or the like on the belt or near the pressure roller or print head. Doing so could cause them to be entangled in the belt, pressure roller, or print head, damaging this machine. Before turning the power on, check that there is nothing left near the moving parts, such as on the belt or near the print head.

Front

- 1** Move the display of the control PC to the outer side.
- 2** Open all the front covers of the machine.
- 3** Check that there are no tools, fasteners, or the like left on the belt or near the carriage or print head.

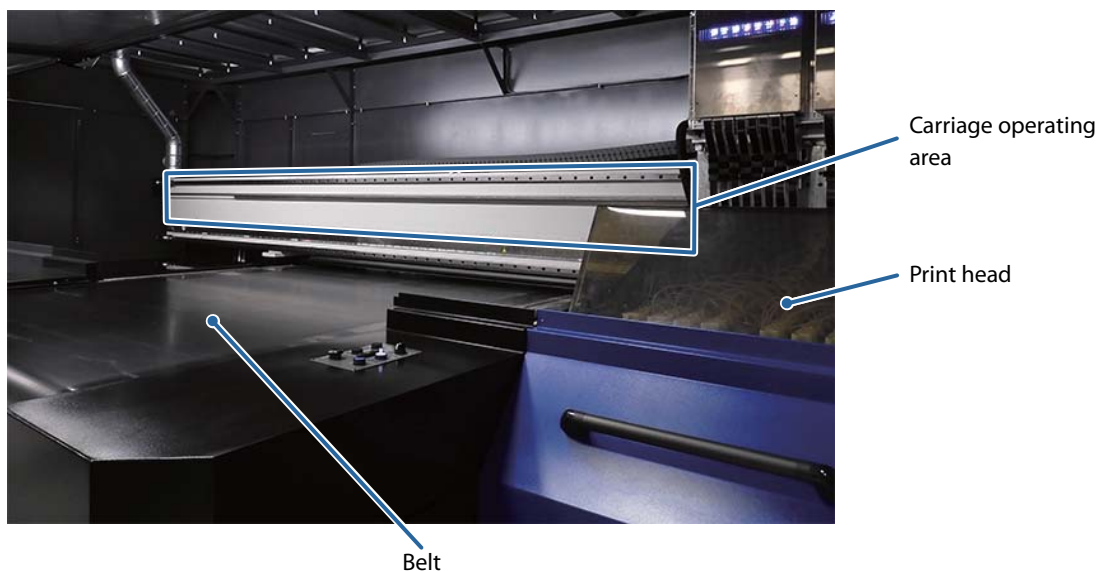

- 4** Check to see if the display of the control PC has been moved to the outer side. If it has not been moved, move the display of the control PC to the outer side.
- 5** Close all the front covers.

Rear

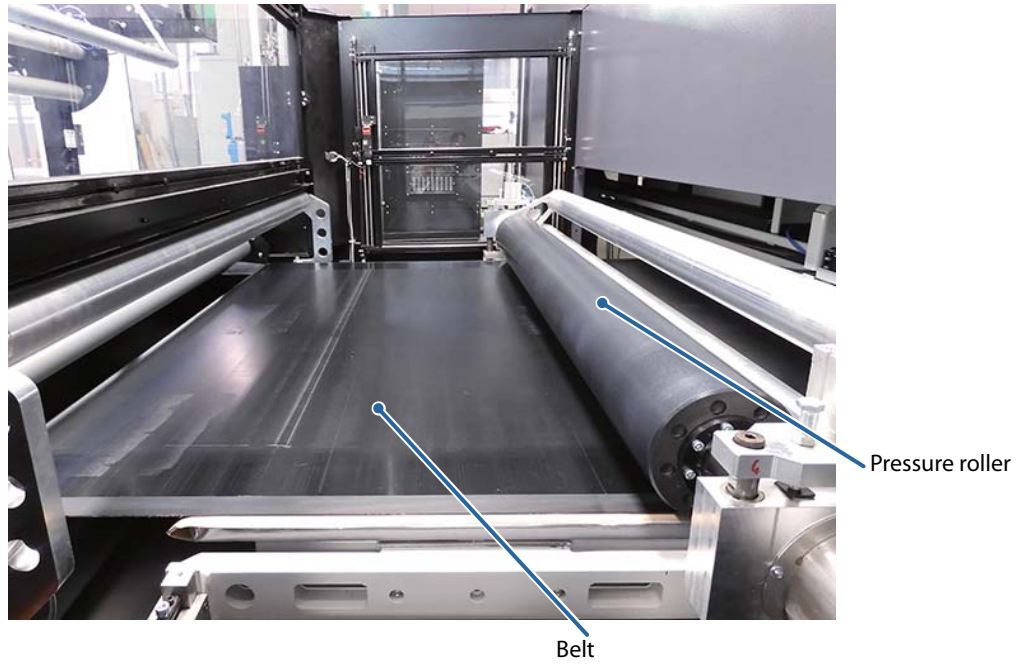

- 1 Open the rear covers of this machine.
- 2 Check that there are no tools, fasteners, or the like left near the belt or the pressure roller.





- 3 Close the rear covers.

List of Maintenance Tools and Supplies

Prepare the items listed below before starting inspection/cleaning.

Item	Details/Use
<p>Clean stick (Dedicated consumables/commercially available)</p> 	<p>Use for various types of cleaning. Dedicated consumables (recommended): Item name: Clean Stick B Model No.: C13S090011 Epson recommends the following if purchasing yourself: ASPURE from AS ONE Corporation Model No.: AP125PCT When using commercially available products, choose products that generate little dust and fibers.</p>
<p>Cleaning cloth (Dedicated consumables/commercially available)</p> 	<p>Nonwoven fabric used for various types of cleaning. Dedicated consumables (recommended): Item name: Head Cleaning Cloth A Model No.: C13S210050 Epson recommends the following if purchasing yourself: Berkshire Corporation SuperPolx® 1200 When using commercially available products, choose products that generate little dust and fibers.</p>
<p>Maintenance liquid (Dedicated consumables)</p>	<p>This is a dedicated cleaning liquid for removing ink that has adhered to the machine. Do not dilute the liquid. Dedicated consumables: Item Name: Maintenance Liquid Model No.: C13T42X000 *Commercially available cleaning liquids are not covered by warranty.</p>
<p>NOZZLE RECOVERY JIG (Dedicated consumables)</p>	<p>Use the brush to clean the surface of the nozzles. Dedicated consumables: Item Name: NOZZLE RECOVERY JIG Model no.: 1793619</p>
<p>Plastic container (Commercially available)</p> 	<p>Use to contain the maintenance liquid or ethanol for cleaning with the clean stick or a cleaning cloth. Epson recommends the following: Disposable cup *Epson recommends using disposable cups. However, they can be reused if cleaned thoroughly.</p>

Item	Details/Use
Rubber gloves (Commercially available)	Use during all types of cleaning. Epson recommends using disposable rubber gloves.
Eye protection (Commercially available) 	Use during all types of cleaning. Epson recommends using eye protection that protects against chemical splashes.
Tweezers (Commercially available)	Use to remove fluffy material and other debris when cleaning caps. Epson recommends using plastic tweezers.
Hex key (Commercially available) 	Used to fasten or loosen screws on the machine.
Spanner (width: 7 mm) (Commercially available) 	Used to fasten or loosen screws on the machine.
Lighting (Commercially available)	Use to illuminate the area where you are working inside the machine, such as when cleaning the area around the heads. Epson recommends using free-standing lights, so that you can use both hands when working.
Scraper/Brush (Commercially available)	Use for flushing plate cleaning Epson recommends using plastic or rubber scrapers/brushes.
Feeler gauge (Commercially available)	Used for height check using the fabric slack detection sensor. A hex key (width: 2 mm) can be used as a substitute.
Ethanol (Commercially available)	Use for replacing wipers.

Item	Details/Use
Grease (Commercially available)	Grease added to the scan spindle. Epson recommends the following: NSK Ltd. Model No.: NSK GRS AS2
Tray	Use this to carry the plastic container. We recommend using a tray as the cleaning liquid may spill or drip from the plastic container.
Anti-foaming agent (Commercially available)	Anti-foaming agent for applying to the belt cleaning unit. This is only necessary when using acid ink.
Brush (Commercially available)	Use when applying anti-foaming agent to the belt cleaning unit. This is only necessary when using acid ink.

Maintenance Work List

Inspection/Cleaning

Item	Timing				Frequency							Procedure details	
	Before beginning work	During work	After completing work	When problem occurs	Every shift	Every day	Every week	Every half month	Every month	Every six months	Every year		When problem occurs
<input type="checkbox"/> Checking the Area Around Operating Parts	<input type="radio"/>				<input type="radio"/>								Page 117
<input type="checkbox"/> Checking the Operation of the Emergency Stop Equipment	<input type="radio"/>								<input type="radio"/>				Page 117
<input type="checkbox"/> Checking the Regulator Water Level of the Compressed Air Route	<input type="radio"/>						<input type="radio"/>						Page 119
<input type="checkbox"/> Inspecting for Leaks in the Ink Path	<input type="radio"/>			<input type="radio"/>		<input type="radio"/>						<input type="radio"/>	Page 120
<input type="checkbox"/> Cleaning Caps, Wipers, and Flushing Plate (Home)		<input type="radio"/>	<input type="radio"/>	<input type="radio"/>			<input type="radio"/>					<input type="radio"/>	Page 120
<input type="checkbox"/> Cleaning the Flushing Plate (Full)		<input type="radio"/>	<input type="radio"/>			<input type="radio"/>							Page 127
<input type="checkbox"/> Cleaning the Area Around the Print Heads		<input type="radio"/>	<input type="radio"/>	<input type="radio"/>			<input type="radio"/>					<input type="radio"/> *1	Page 130
<input type="checkbox"/> Cleaning the Print Head Cover		<input type="radio"/>	<input type="radio"/>									<input type="radio"/>	Page 135
<input type="checkbox"/> Checking the Height with the Foreign Material Detection Sensor					<input type="radio"/> *2							<input type="radio"/> *2	Page 139
<input type="checkbox"/> Cleaning the Cleaning Brushes and the Area Around Them			<input type="radio"/>				<input type="radio"/>					<input type="radio"/> *1	Page 140
<input type="checkbox"/> Adding Grease to the Scan Spindle	<input type="radio"/>									<input type="radio"/>			Page 142
<input type="checkbox"/> Checking for Water Leaks in the Pipe Joints	<input type="radio"/>					<input type="radio"/>							Page 145
<input type="checkbox"/> Checking the Regulator in the Carriage Pressure Air System	<input type="radio"/>								<input type="radio"/>				Page 146
<input type="checkbox"/> Cleaning/Replacing the Mist Filter				<input type="radio"/>				<input type="radio"/> Cleaning				<input type="radio"/> Replacement	Page 148
<input type="checkbox"/> Cleaning/Replacing the Cooling Fan Filter				<input type="radio"/>					<input type="radio"/> Cleaning			<input type="radio"/> Replacement	Page 149

Item	Timing				Frequency							Procedure details	
	Before beginning work	During work	After completing work	When problem occurs	Every shift	Every day	Every week	Every half month	Every month	Every six months	Every year		When problem occurs
<input type="checkbox"/> Checking the Blower and Cleaning/Replacing the Filter				○					○ Inspection			○ Cleaning/ Replacement	Page 154
<input type="checkbox"/> Checking the Cable Protection Condition	○								○				Page 156
<input type="checkbox"/> Cleaning Around the Image Quality Adjustment Camera	○										○		Page 157
<input type="checkbox"/> Inspecting the Hinges on the Front Covers	○					○							Page 161

*1: After printing on fabric with fuzzy surface

*2: When changing the fabric type

Replacing Consumables

Item	Timing	Procedure details
<input type="checkbox"/> Replacing the Washing T-shaped Scraper	When the area in contact with the belt is worn/deteriorated	Page 164
<input type="checkbox"/> Replacing the Washing Silicone Scraper		Page 169
<input type="checkbox"/> Replacing the Wiper	When the wiper is damaged When a message is displayed on the Control PC prompting you to replace the part	Page 170
<input type="checkbox"/> Replacing the ink tubes for the pump	When the ink tube is torn or otherwise damaged When a message is displayed on the Control PC prompting you to replace the part	Page 174
<input type="checkbox"/> Replacing the Cap Unit	When a problem occurs, such as when clogged nozzles are not resolved by cleaning	Page 180

Other Maintenance

Item	Timing	Procedure details
<input type="checkbox"/> Applying anti-foaming agent to the belt cleaning unit (only when using acid ink)	Once every two days before beginning work When ink sticks to the belt and foams	Page 187
<input type="checkbox"/> Glue Removal	Application of glue when the fabric attached to the belt rises slightly When there is damage such as peeling of the glue	Page 192
<input type="checkbox"/> Glue Application		Page 212
<input type="checkbox"/> Shaking the Ink Cartridges	When the machine was not used for a long period of time with the ink cartridges still installed	Page 242

Print Head Replacement

Item	Timing	Procedure details
<input type="checkbox"/> Cleaning the Head Nozzle Surface (Clean Stick)	If nozzles are still clogged even after performing " Head Cleaning " on page 55 several times	Page 245
<input type="checkbox"/> Cleaning the Head Nozzle Surface (NOZZLE RECOVERY JIG)	If nozzles are still clogged even after performing " Cleaning the Head Nozzle Surface (Clean Stick) " on page 245 several times	Page 252
<input type="checkbox"/> Print Head Replacement	If nozzles are still clogged even after performing " Cleaning the Head Nozzle Surface (NOZZLE RECOVERY JIG) " on page 252 several times	Page 256

Inspection/Cleaning Procedure

Checking the Area Around Operating Parts

Frequency	Every shift
-----------	-------------

- 1** Confirm that the machine is in Power Off status. (See: "[Power Off/Air Pressure Release Status](#)")
- 2** Check the print head operating area at the front of the machine.
Check areas as described in "[Checking Operating Parts](#)".
- 3** Check the pressure roller operating area at the rear of the machine.
Check areas as described in "[Supplying Water to and Checking the Belt Cleaning Unit](#)".

Checking the Operation of the Emergency Stop Equipment

Frequency	Every month Inspection before beginning work
-----------	---

Confirm that all emergency stop functions in the system operate properly.

Checking the Emergency Stop Buttons on the Machine

Check the operation of each of the 5 emergency stop buttons on the machine.

- 1** Press the emergency stop button.
- 2** Confirm that a message is displayed on the screen of the control PC, and that the signal lamp is red.

- 3 Turn the emergency stop button to the right to release the emergency stop status. [Release] on the screen of the control PC is enabled.



- 4 Press [Release]. Confirm that the signal lamp is green.
- 5 Check the message on the control PC screen, and press [Return to Origin].
The head returns to the origin. The signal lamp flashes green.
- 6 Confirm that the screen on the control PC returns to its previous state, and that "Standby" is displayed for the status. The signal lamp is green.
- 7 There are five emergency stop buttons around the machine. Repeat steps 1 to 6 to check the operation of each emergency stop button.

Checking the Emergency Stop Functions in the System

If the system is linked with the emergency stop system of other equipment, check if the system's emergency stop function for that equipment is operating normally.

Checking the Regulator Water Level of the Compressed Air Route

Frequency	Every week
-----------	------------

1 Confirm that the machine is in Power Off status. (See: "[Power Off/Air Pressure Release Status](#)")

2 Check the water level of the compressed air route regulator at the rear of the machine.

If water has accumulated, press the orange button on the bottom of the regulator to release and discharge the water.



Inspecting for Leaks in the Ink Path

Frequency	Every day or when an error related to leaking occurs
-----------	--

Check for ink leaks in each ink path.

Check areas as described in "[Inspecting the Ink Path](#)".

If any of the following conditions are discovered during an inspection, contact your dealer or Epson Support for assistance.

- Disconnected ink path
- Ink leaking from connection area along the ink path
- Evidence of ink adhesion/dripping/accumulation in the surrounding area

Depending on the condition of the machine, either performing cleaning yourself or request repairs from your dealer or Epson Support.

When performing cleaning yourself

Personal protective equipment	Protective gloves and clothing, eye protection
Required items	Prepare the following (as necessary): Clean stick, cleaning cloth, maintenance liquid

Cleaning Caps, Wipers, and Flushing Plate (Home)

Frequency	Every day or when a problem occurs (when color mixing, nozzle clogging, or other problem occurs that is not resolved by cleaning)
Personal protective equipment	Protective gloves and clothing, eye protection
Required items	Clean stick, maintenance liquid, plastic container, tweezers



For cleaning, be sure to use the dedicated maintenance liquid.

- 1** Confirm that the machine is in Standby status. (See: "[Standby Status](#)")
- 2** On the screen of the control PC, press Head Maintenance - [Move to Full] on the [Regular Check] tab in the [Maintenance] menu.
The print heads move to the Full side. The side doors unlock.

- 3** Move the display of the control PC to the outer side.



- 4** Open the front cover (Home).

- 5** Open the maintenance cover beside the belt on the Home side, and align it with the maintenance cover below the front cover.



- 6** Grab the handle of the maintenance cover below the front cover and slowly open the maintenance cover.



- 7** While pulling the knob of the stopper on the cleaning station toward you with your left hand, use your right hand to slightly pull out the cleaning station.



8 Grab the handle on the cleaning station and slowly pull it out toward you.

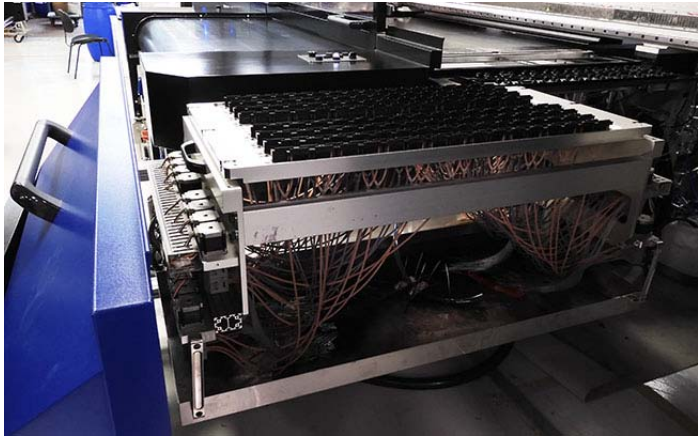

9 Lightly wipe off dirt from around the cap using the cleaning cloth or clean stick moistened with maintenance liquid.



- Do not wipe around the cap with force. Doing so may damage the lip section of the cap, deteriorate nozzle recovery by cleaning, or result in nozzle clogging.
- Do not allow the cleaning cloth or clean stick to touch the absorber or metal part in the cap. Doing so may deform the parts, resulting in damage to the head nozzle surface or nozzle clogging.

Absorber

Metal part

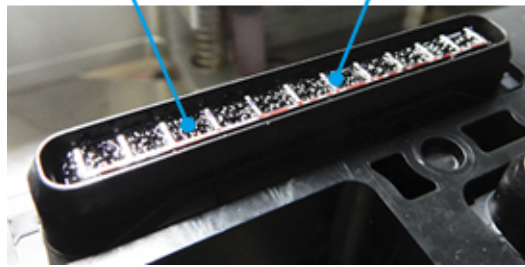

Wipe off in the direction of the arrows.

For clean stick



For cleaning cloth



10 If there is any fluffy dust adhering to the cap, use tweezers to pinch and remove it.



Do not pinch the lip section of the cap with the tweezers. Doing so may damage the lip section, deteriorate nozzle recovery by cleaning, or result in nozzle clogging.



Lip section



11 Move into the machine from the side door (Home).

12 Lightly wipe off dirt from around the wiper using the cleaning cloth or clean stick moistened with maintenance liquid. Wipe off in the direction of the arrows. The same applies to the cleaning cloth.



Do not pull the rubber part of the wipers.

Wiper section



Rear side of wiper

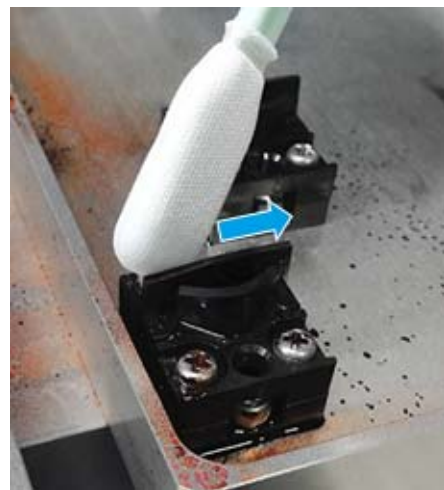

- 13** Clean away any waste ink that has built up on the flushing plate (Home).
- 14** Use the scraper to sweep the ink remaining on the plate in the direction of the arrow and toward the discharge outlet to remove it.



If waste ink is dried, apply maintenance liquid to dissolve the ink before cleaning.



- 15** Use a cleaning cloth to wipe away any ink that has adhered to the scraper.
- 16** When cleaning is finished, move out of the machine from the side door.
- 17** Return the cleaning station.
Grabbing the cleaning station's handle and being careful not to pinch any cables, slowly push it back into its original position until you hear the stopper click into place.
- 18** Slowly close the maintenance cover below the front cover.
- 19** Return the maintenance cover beside the belt (on the Home side) to its original position.
- 20** Check to see if the display of the control PC has been moved to the outer side.
If it has not been moved, move the display of the control PC to the outer side.
- 21** Close the front cover (Home).
- 22** Return the control PC to its original position.

23 Make sure nobody is inside the machine, then close the side door and press the Confirm button.

24 On the screen of the control PC, press [Capping].
The print heads move to the Home side. The side doors lock.
This completes the cleaning procedure.

25 Perform head cleaning.
Refer to "Head Cleaning" for the procedure.

26 Perform a nozzle check.
Refer to "Nozzle Check" for the procedure.

Cleaning the Flushing Plate (Full)

Frequency	Every day, when printing ends
Personal protective equipment	Protective gloves and clothing, eye protection
Required items	Scraper/brush, maintenance liquid, container, cleaning cloth



CAUTION:

Be sure to wear eye protection.
Failure to do so could cause ink to splash into the eyes.



If too much time passes between cleanings, the nozzles might become clogged. When cleaning is complete, perform head cleaning

Clean away any waste ink that has built up on the flushing plate (Full).

1 Confirm that the machine is in Standby status. (See: "Standby Status")

2 Open the front cover (Full).

- 3 Use the scraper to sweep the ink remaining on the flushing plate (Full) from the rear to the front of the machine and toward the discharge outlet to remove it.



If waste ink is dried, apply maintenance liquid to dissolve the ink before cleaning.

Note:

If the scraper is not long enough to sweep the ink, move into the machine from the side door (Full). Then use the scraper to sweep the ink remaining on the flushing plate (Full) from the rear to the front of the machine and toward the discharge outlet to remove it.

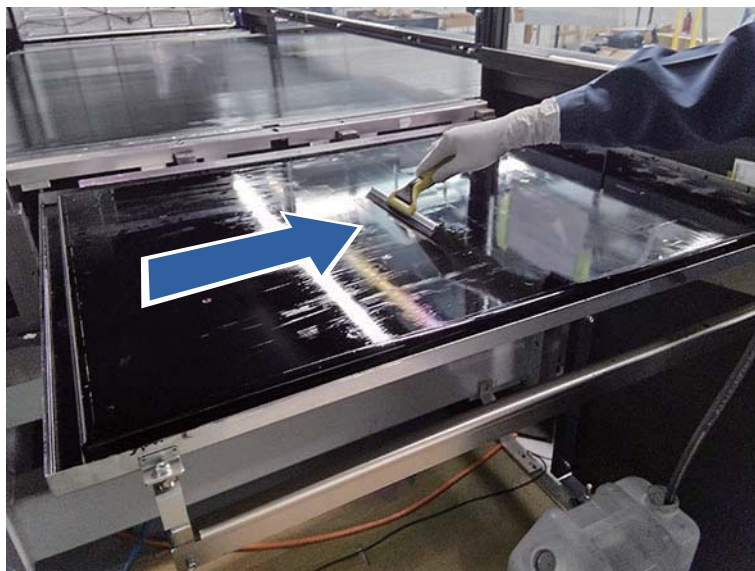

- 4 Use a cleaning cloth to wipe away any ink that has adhered to the scraper.
- 5 Close the front cover (Full).

6 Perform head cleaning.

Refer to ["Head Cleaning" on page 55](#) for the procedure.

This completes the cleaning procedure.

Cleaning the Area Around the Print Heads

Frequency	When printing on fabric with a fuzzy surface
Personal protective equipment	Protective gloves and clothing, eye protection
Required items	Maintenance liquid, container, clean stick, wipe cloths, lighting



If too much time passes between cleanings, the nozzles might become clogged. When cleaning is complete, perform head cleaning

- 1** Confirm that the machine is in Standby status. (See: "[Standby Status](#)")
- 2** On the screen of the control PC, press Head Maintenance - [Move to Home] on the [Regular Check] tab in the [Maintenance] menu.
The print heads move up. The side doors unlock.
- 3** Move the display of the control PC to the outer side.



- 4** Open the front cover (Home).
- 5** Open the maintenance cover beside the belt on the Home side, and align it with the blue cover.
- 6** Using both hands, grab the handle of the maintenance cover and slowly open the maintenance cover.
- 7** While pulling the knob of the stopper on the cleaning station toward you with your left hand, use your right hand to slightly pull out the cleaning station.

- 8** Grab the handle on the cleaning station and slowly pull it out toward you.
- 9** Wear eye protection.
- 10** Taking the items below with you, move into the machine from the side door (Home).
Cleaning cloth, clean stick, container of maintenance liquid, lighting

11 Wipe dirt from the carriage plate.

Using a cleaning cloth moistened with maintenance liquid, wipe away ink, fluffy dust, and other dirt.



Be careful not to touch the head.

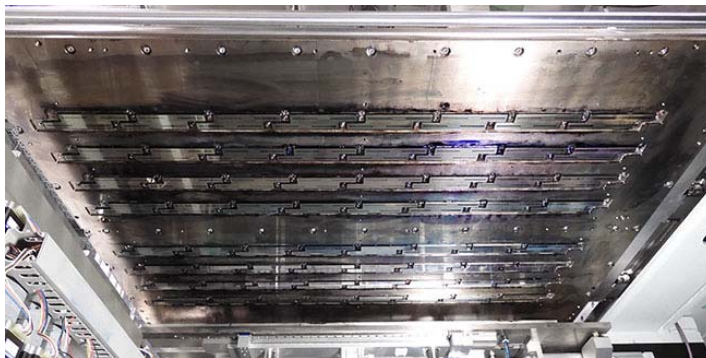

Locations to clean

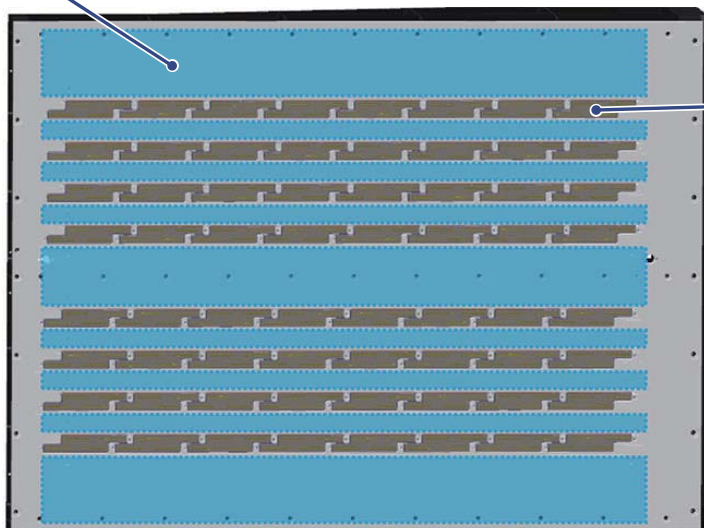

12 Shining the light on the print head, check the area around the head for debris, fluffy dust, and other dirt.

If it is not dirty, this completes the cleaning procedure. If it is dirty, perform cleaning using the following procedure.

13 While shining the light on the print head and using a clean stick moistened with maintenance liquid, wipe off fluffy dust from the head front and ink stains from the head side face.

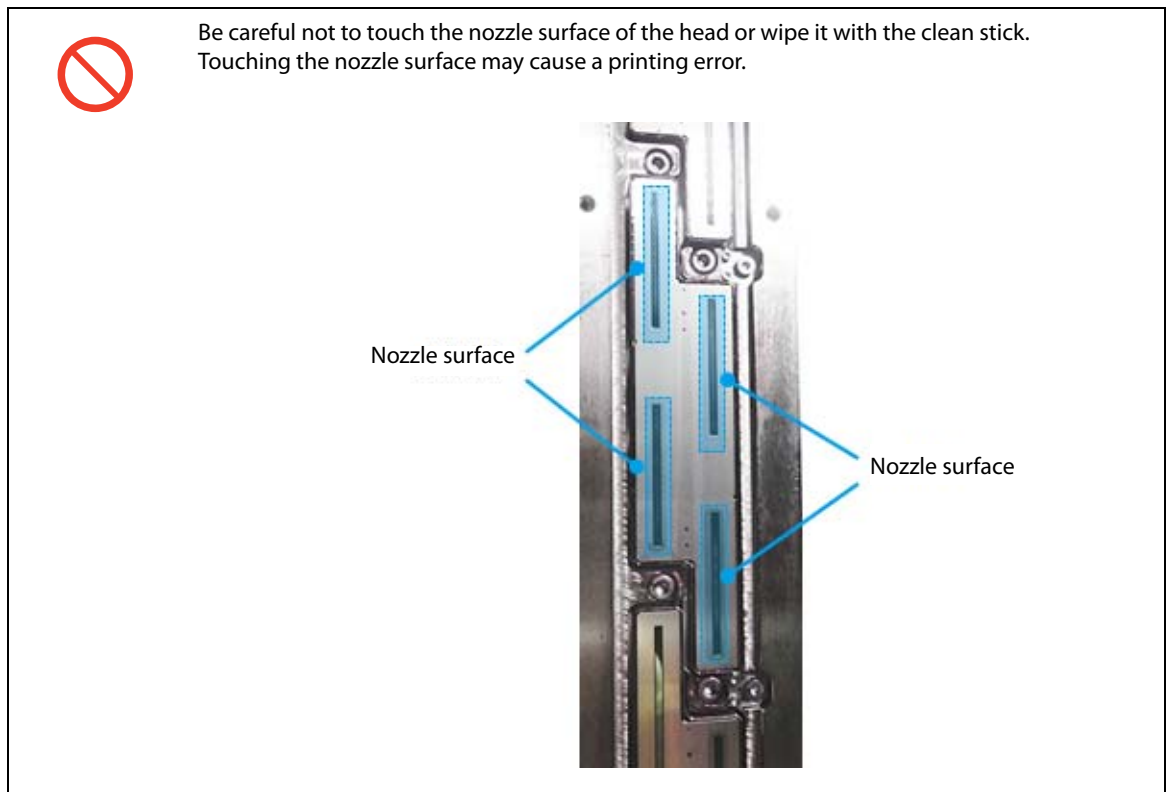

Fluffy dust is often stuck on the print head, so wipe away any using the clean stick.

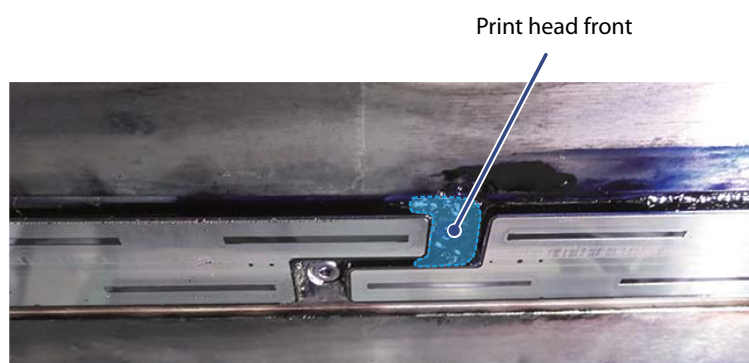

Completely wipe off ink-stained fiber or similar dust. Printing with such dust remaining on the parts may cause ink to drip on the fabric, resulting in a printing error.



After moving the head carriage to the outside, be sure to return it to the inside. If it is not returned to the inside, the sensor on the head carriage may activate, and you may not be able to execute [Return to Origin].

- 14** When cleaning is finished, move out of the machine from the side door (Full).
- 15** Return the cleaning station.
Grabbing the cleaning station's handle and being careful not to pinch any cables, slowly push it back into its original position until you hear the stopper click into place.
- 16** Slowly close the maintenance cover below the front cover.
- 17** Return the maintenance cover beside the belt (on the Home side) to its original position.
- 18** Check to see if the display of the control PC has been moved to the outer side.
If it has not been moved, move the display of the control PC to the outer side.
- 19** Close the front cover (Home).
- 20** Return the control PC to its original position.
- 21** Make sure nobody is inside the machine, then close the side door and press the Confirm button.
- 22** On the screen of the control PC, press [Capping].
The heads are capped. The side doors lock.
This completes the cleaning procedure.
- 23** Perform head cleaning.
Refer to "[Head Cleaning](#)" for the procedure.
- 24** Perform a nozzle check.
Refer to "[Nozzle Check](#)" for the procedure.

Cleaning the Print Head Cover

Frequency	When necessary or when dirt is noticeable
Personal protective equipment	Protective gloves and clothing
Required items	Cleaning cloth, maintenance liquid, plastic container



For cleaning, be sure to use the dedicated maintenance liquid.

- 1** Confirm that the machine is in Standby status. (See: "[Standby Status](#)")
- 2** Move the display of the control PC to the outer side.



- 3** Open the front cover (Home).

- 4 Using a cleaning cloth moistened with maintenance liquid, wipe the surface of the print head cover, as far as you can reach.**



Completely wipe off ink-stained fiber or similar dust. Printing with such dust remaining on the parts may cause ink to drip on the fabric, resulting in a printing error.



- 5 Check to see if the display of the control PC has been moved to the outer side.**
If it has not been moved, move the display of the control PC to the outer side.
- 6 When cleaning is finished, close the front cover (Home).**
- 7 Return the control PC to its original position.**
- 8 On the screen of the control PC, press Side Door - [Unlock] on the [Regular Check] tab in the [Maintenance] menu.**
- 9 Taking the items below with you, move into the machine from the side door (Home).**
Cleaning cloth, plastic container of maintenance liquid

- 10** Using a cleaning cloth moistened with maintenance liquid, wipe the surface of the print head cover, as far as you can reach.



Completely wipe off ink-stained fiber or similar dust. Printing with such dust remaining on the parts may cause ink to drip on the fabric, resulting in a printing error.



- 11** When cleaning is finished, move out of the machine.
- 12** Make sure nobody is inside the machine, then close the side door (Home) and press the Confirm button.
- 13** On the screen of the control PC, press Side Doors - [Lock].
- 14** Press Head Maintenance - [Move to Full] on the [Regular Check] tab in the [Maintenance] menu.
The print heads move to the Full side. The side doors unlock.
- 15** Taking the items below with you, move into the machine from the side door (Full).
Cleaning cloth, plastic container of maintenance liquid

- 16** Using a cleaning cloth moistened with maintenance liquid, wipe the surface of the head cover, as far as you can reach.



Completely wipe off ink-stained fiber or similar dust. Printing with such dust remaining on the parts may cause ink to drip on the fabric, resulting in a printing error.



- 17** When cleaning is finished, move out of the machine from the side door (Full).
- 18** Make sure nobody is inside the machine, then close the side door and press the Confirm button.
- 19** On the screen of the control PC, press [Capping].
The print heads move to the Home side. The side doors lock.
This completes the cleaning procedure.

Checking the Height with the Foreign Material Detection Sensor

Frequency	Every shift or when changing the fabric type
Personal protective equipment	Protective gloves and clothing
Required items	Hex key (width: 2 mm) or feeler gauge (2 mm)

Check that the foreign material detection sensor is operating normally.

- 1** Confirm that the machine is in Standby status. (See: "[Standby Status](#)")
- 2** Before starting work, check the detection threshold value with nothing placed on the belt.

Check the foreign material detection sensor controller on the front panel to confirm that the displayed value is 9999 or higher.



- 3** Place the hex key (width: 2 mm) or feeler gauge (2 mm) on the Home side of the belt.
- 4** Press the backfeed button to feed the belt in the reverse direction.
Feed to the position where the hex key or feeler gauge is exposed to the sensor laser beam.
- 5** Move to the machine rear, and check that the tool is exposed to the laser beam through the gap at the top of the pressure roller.
- 6** Check the foreign material detection sensor display again to confirm that the detection threshold value is at least 2000 less than the previous value.
- 7** Check on the Full side of the belt in the same way.

Cleaning the Cleaning Brushes and the Area Around Them

Frequency	Every week/When necessary (After printing on fabric with fuzzy surface)
Personal protective equipment	Protective gloves and clothing

- 1** Confirm that the machine is in Power Off status. (See: "[Power Off/Air Pressure Release Status](#)")
- 2** Remove each screw at the two locations that secure the belt cleaning unit.



- 3** Pull the belt cleaning unit toward you until it is out.



4 Remove all fiber and other dust from the cleaning brushes.

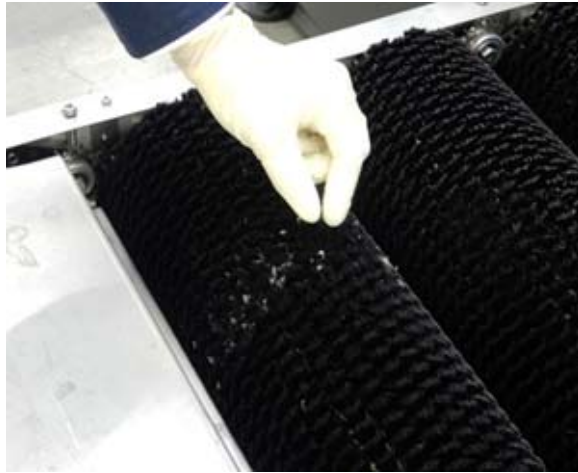

For the cleaning brushes, a metallic brush as shown below can also be used.



5 Use a wipe cloth to wipe away any fluffy dust that has adhered to the scraper.

6 When cleaning is finished, put the belt cleaning unit back in the original position.



Insert the belt cleaning unit straight into its original position.
If put in at a slant, the frame of the belt cleaning unit may touch the side, making it difficult to insert.



CAUTION:

When pushing the belt cleaning unit back to its original position, do not bend or twist the drain hose. If the drain hose gets bent or twisted, wastewater may back up and overflow from the cleaning tank.

7 Tighten the two screws by hand to secure the belt cleaning unit.

Adding Grease to the Scan Spindle

Frequency	Every six months, before beginning work
Personal protective equipment	Protective gloves and clothing
Required items	Scan spindle grease, grease gun, cleaning cloths

Add grease to the scan spindle.

- 1 Confirm that the machine is in Standby status.**
For more information, refer to "[Standby Status](#)" on page 108.
- 2 Press Head Maintenance - [Move to Full] on the [Regular Check] tab in the [Maintenance] menu.**
The print heads move to the Full side. The side doors unlock.
- 3 Taking the items below with you, move into the machine from the side door (Full).**
Scan spindle grease, grease gun, cleaning cloths

- 4** Using the grease pump, add grease through the oil filler holes (six upper and lower holes) of the linear block on the left side of the print heads. Use cleaning cloths to wipe off any excess grease or ink adhering to the oil filler holes and surrounding area before working.

Note:

The proper grease amount is 1 to 3 g for each oil filler hole.

**WARNING:**

Do not add too much grease. Doing so can result in excess grease dripping onto fabric, resulting in a printing error.

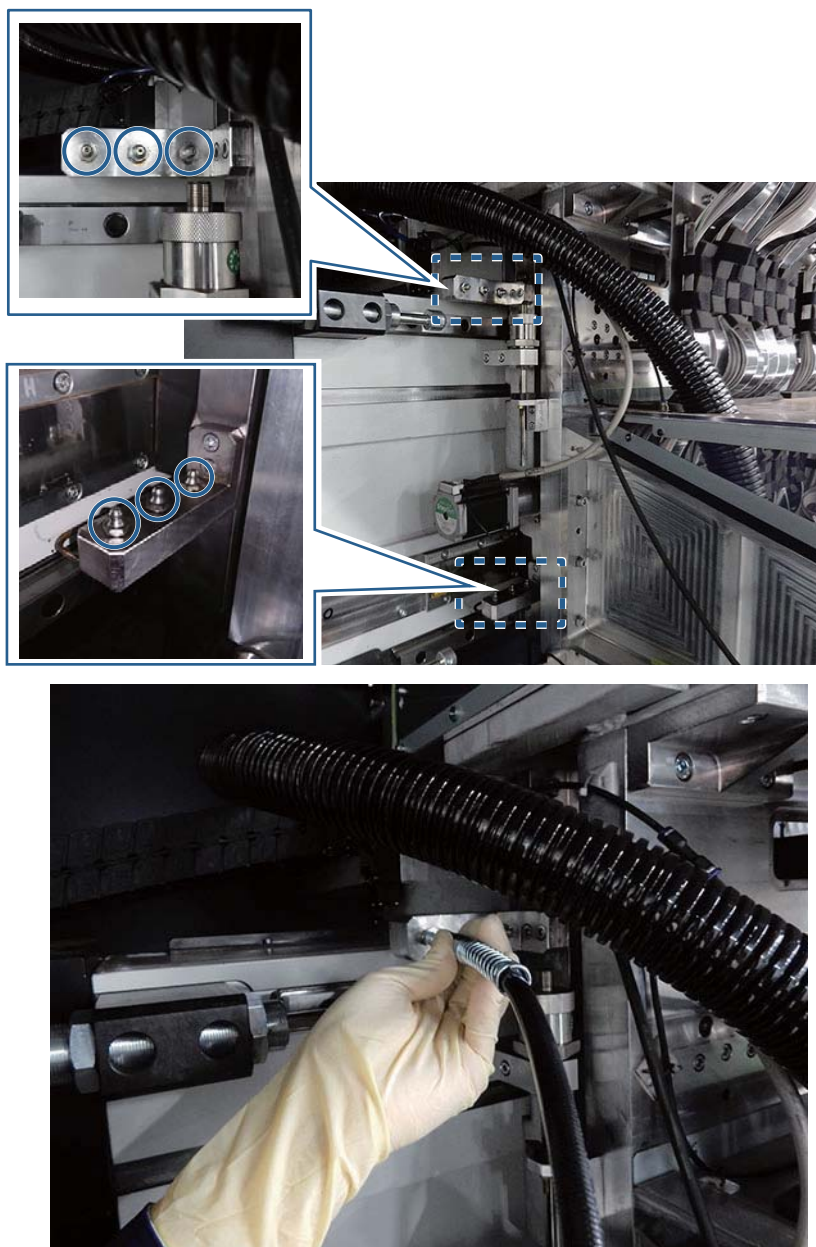

-
- 5** When work is finished, move out of the machine from the side door (Full).
 - 6** Make sure nobody is inside the machine, then close the side door and press the Confirm button.
 - 7** On the screen of the control PC, press [Capping].
The print heads move to the Home side. The side doors lock.
This completes the work.

Checking for Water Leaks in the Pipe Joints

Frequency	Every day
-----------	-----------

- 1 Confirm that the machine is in Power Off status. (See: "[Power Off/Air Pressure Release Status](#)")
- 2 Confirm that the joints (1 and 2) for the belt cleaning tank of the belt cleaning unit are not loose and are free from water leaks.

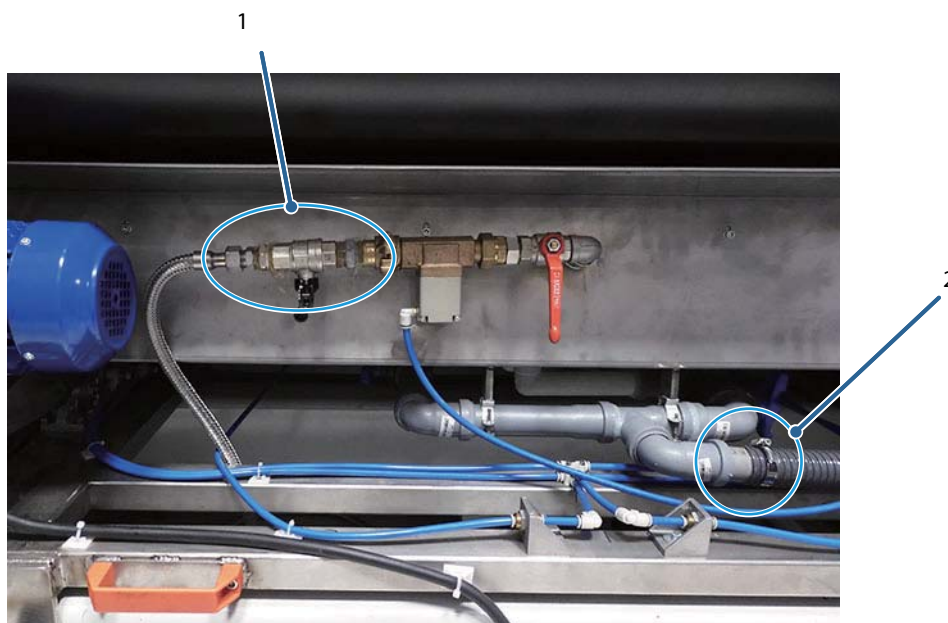

Checking the Regulator in the Carriage Pressure Air System

Frequency	Every month
-----------	-------------

- 1** Confirm that the machine is in Standby status. (See: "[Standby Status](#)")
- 2** On the screen of the control PC, press Side Door - [Unlock] on the [Regular Check] tab in the [Maintenance] menu.
- 3** Move into the machine from the side door (Full).
- 4** Confirm that the dry air system meter indicates the specified value.
Specified value: 4 bar \pm 20%

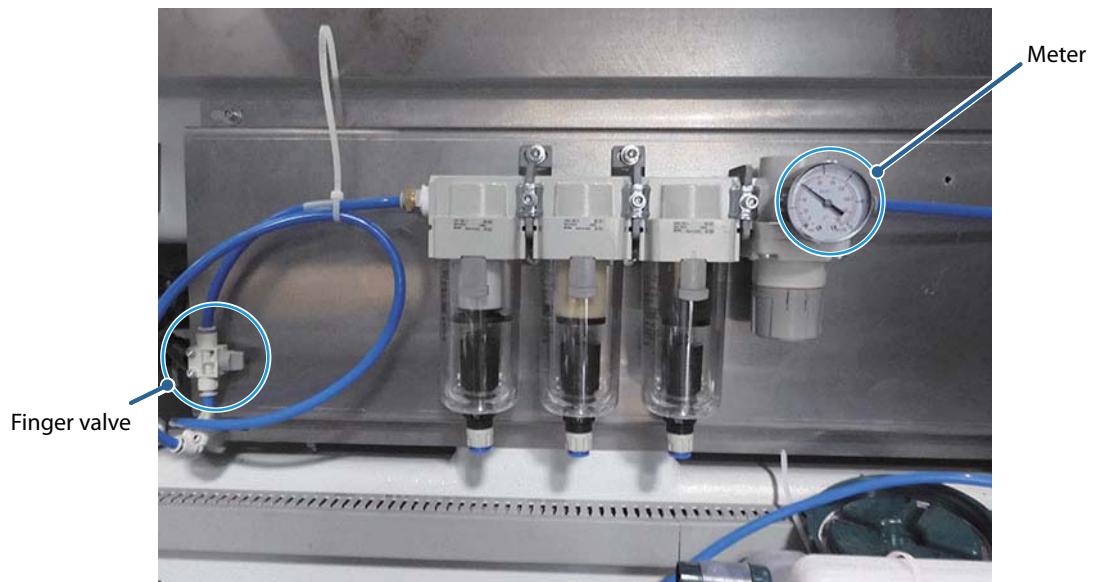

If it does not indicate the specified value, check the following items.

- Is the compressed air supply from the factory normal?
- Is the filter dirty?
- Is the finger valve off?

- 5** Confirm that the flow meter reading indicates the specified value.
Specified value:10 l/m



- 6** When confirmation is finished, move out of the machine from the side door (Full).
- 7** Make sure nobody is inside the machine, then close the side door and press the Confirm button.
- 8** On the screen of the control PC, press [Capping].
The print heads move to the Home side. The side doors lock.
This completes the cleaning procedure.

Cleaning/Replacing the Mist Filter

Frequency	Clean: Every half month Replace: When necessary
Personal protective equipment	Protective gloves
Required items	Replacement: Replacement mist filter

- 1** Confirm that the machine is in Standby status. (See: "[Standby Status](#)")
- 2** On the screen of the control PC, press Side Door - [Unlock] on the [Regular Check] tab in the [Maintenance] menu.
- 3** Move into the machine from the side door (Full).
- 4** Remove the two screws from the mist filter cover and remove the cover.

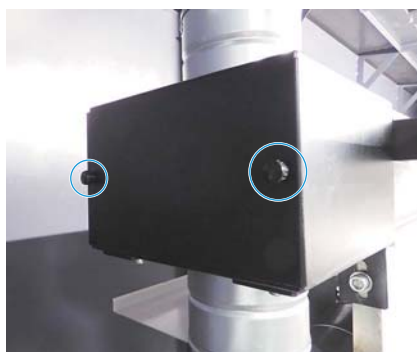

- 5** Pull out the mist filter.

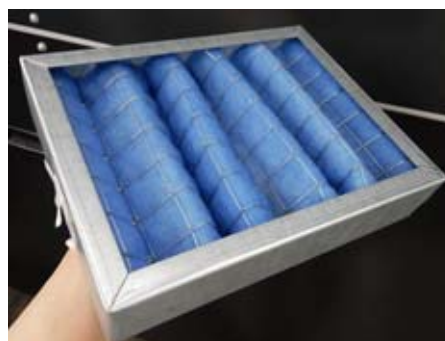

- 6** Clean the removed mist filter with water.

7 Dry the filter thoroughly and attach it again.

Replace the filter if it is extremely dirty.



Make sure that the mist filter is set in the correct direction while attaching it.
Top side: Blue, Bottom side: White

Cleaning/Replacing the Cooling Fan Filters

Frequency	Cleaning: Every month Replacement: When necessary
When to Replace	When cleaning the filter does not solve clogging due to dirt and dust When the filter is deformed or has a hole
Personal protective equipment	Eye protection, protective gloves and clothing, hat
Required items	Replacement cooling fan filter (consumable), hex key (width: 3 mm)

- 1 Confirm that the machine is in Power Off status. (See: [Power Off/Air Pressure Release Status](#))
- 2 Move the display of the control PC to the outer side.



- 3 Open the front cover (Home) and press the side doors unlock button (Home) inside the side door to unlock the side doors.
- 4 Open the side door (Home) and move into the machine.

- 5** Turn the fixing screw of the filter unit by hand to remove it.

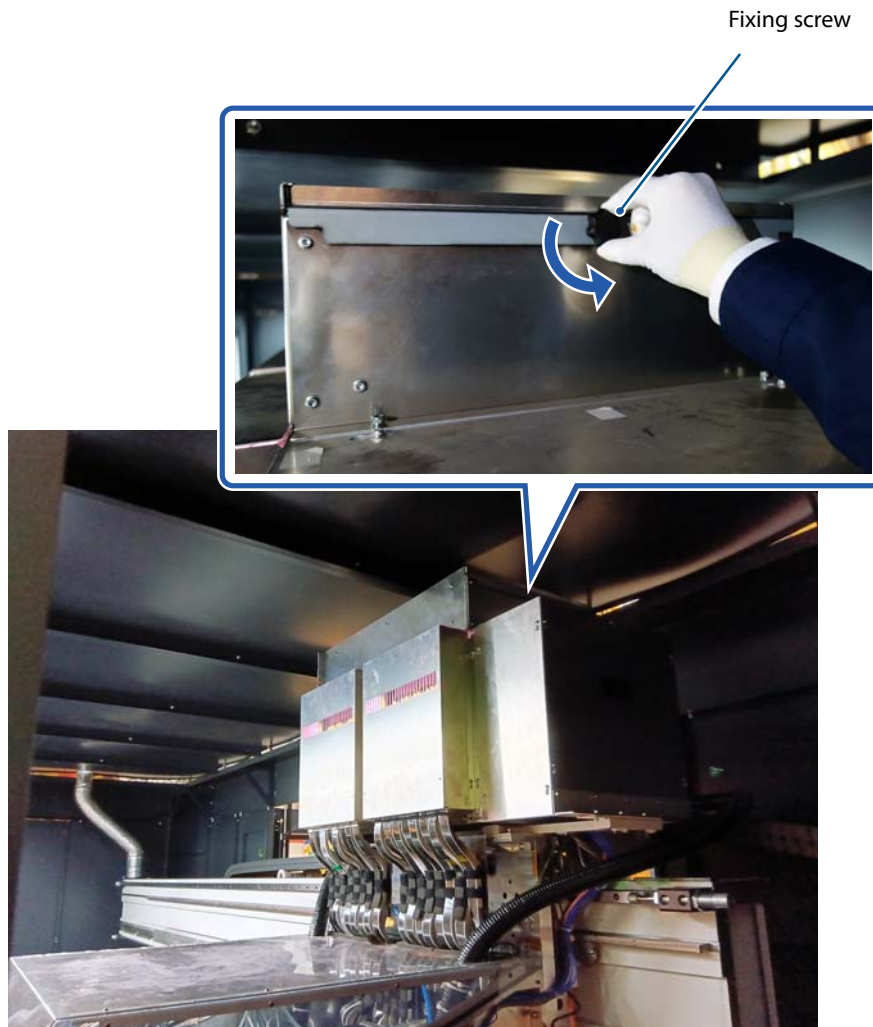

- 6** Place your hand on the top of the filter unit and pull it out.



- 7** Use the hex key (width: 3 mm) to remove the six bolts on the filter unit.

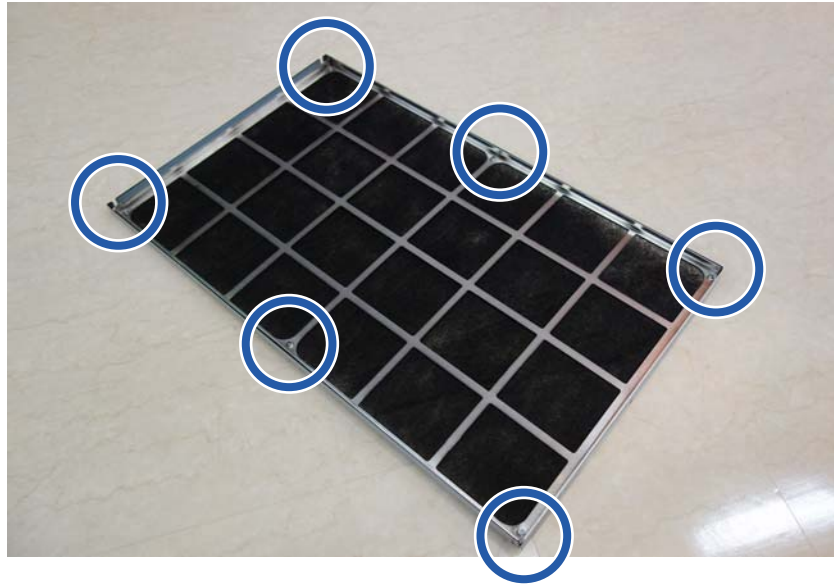

- 8** Remove the presser plate.

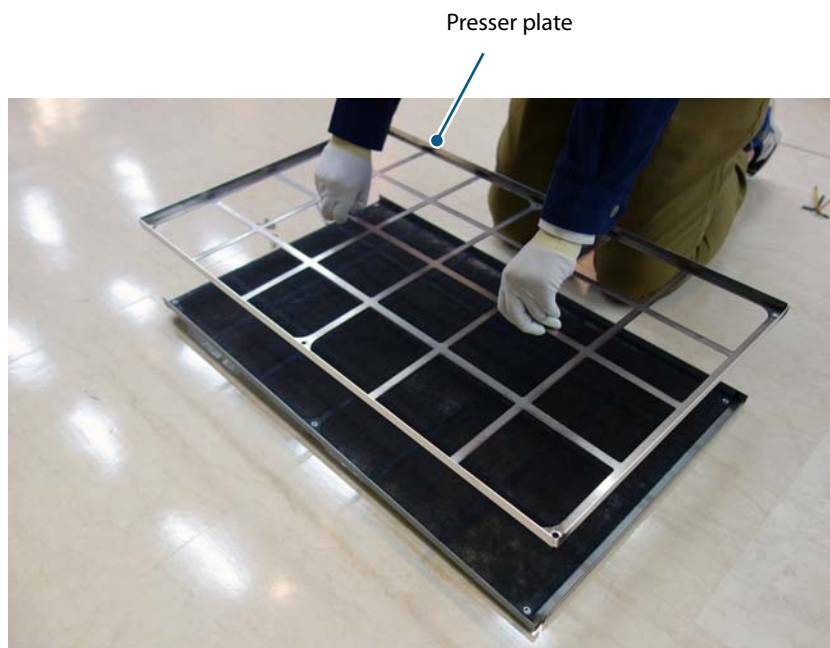

- 9 Remove the cooling fan filter and use a vacuum cleaner to vacuum the dirt and dust.**
Vacuum the dirt and dust until the entire filter is unclogged.
If the filter is extremely dirty or it is deformed or has a hole, replace it with a new one.

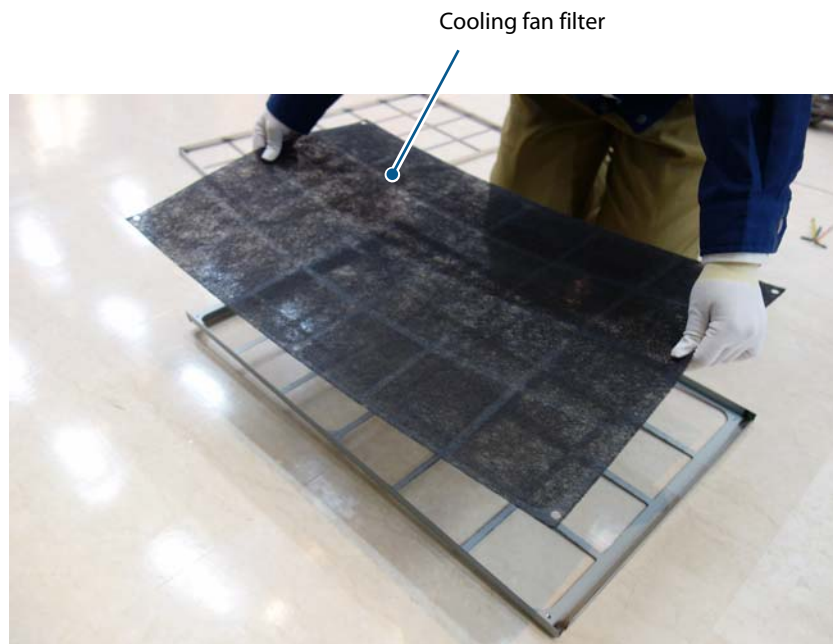

- 10 Return the cooling fan filter to the filter unit and set the presser plate.**
Adjust the filter unit, cooling fan filter, and presser plate to perfectly align the bolt holes in all six locations.

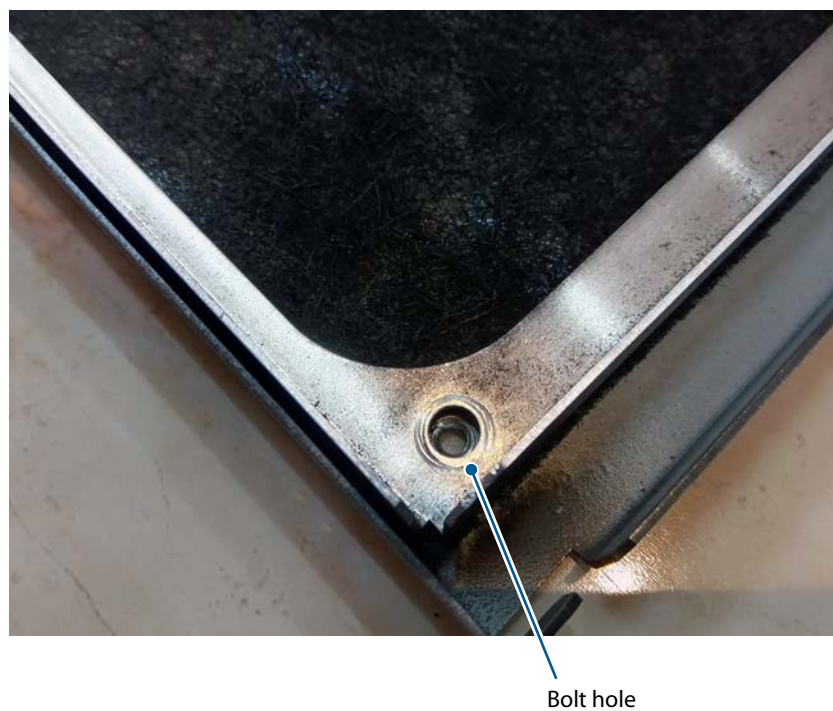

- 11** Use the hex key (width: 3 mm) to tighten the six bolts on the filter unit.
- 12** Return the filter unit to its original position in the machine.
- 13** Turn the fixing screw of the filter unit by hand to tighten it.
- 14** Pull the side doors unlock button (Home) back to lock the side doors.

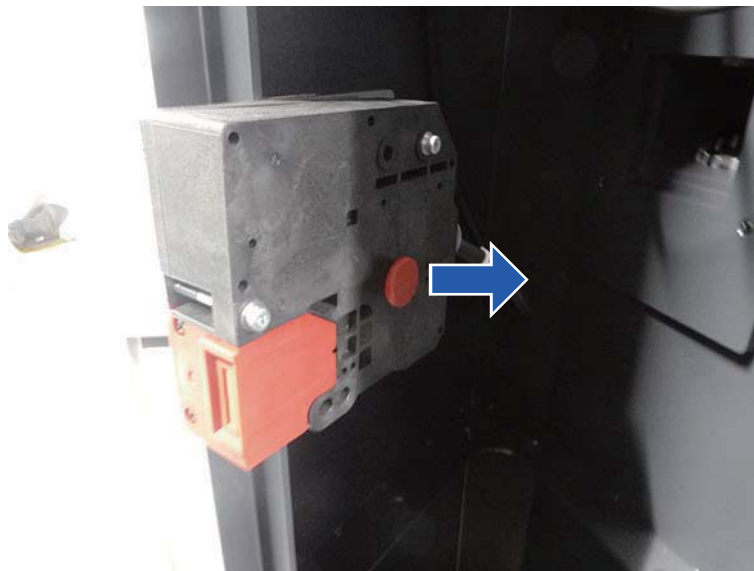

- 15** Exit the machine.
- 16** Make sure nobody is inside the machine, then close the side door.
- 17** Check to see if the display of the control PC has been moved to the outer side.
If it has not been moved, move the display of the control PC to the outer side.
- 18** Close the front cover (Home).
- 19** Return the control PC to its original position.

This completes the work.

Checking the Blower and Cleaning/Replacing the Filter

Frequency	Inspection: Every half month Cleaning/Replacement: When necessary
Personal protective equipment	Protective gloves

Clean the filter for the blower at the rear side of the machine.

- 1** Confirm that the machine is in Power Off status. (See: "[Power Off/Air Pressure Release Status](#)")
- 2** Remove the screw from the filter cover.



- 3** Lift the cover to remove it.



- 4** Remove the filter and clean dirt and dust with a vacuum cleaner.



- 5** After cleaning, attach the filter again.
Replace the filter if it is extremely dirty.

Checking the Cable Protection Condition

Frequency	Every month
-----------	-------------

- 1** Confirm that the machine is in Power Off status. (See: "[Power Off/Air Pressure Release Status](#)")
- 2** Check the cables between the machine and the main electric box for any damage.
- 3** Check the cables between the machine and ink rack for any damage.



Cleaning Around the Image Quality Adjustment Camera

Frequency	Every year, before beginning work
Personal Protective Equipment	Protective gloves and clothing, eye protection
Required items	Maintenance liquid, container, clean stick, cleaning cloth, lighting

- 1 Confirm that the machine is in Standby status.**
For more information, refer to ["Standby Status" on page 108](#).
- 2 On the screen of the control PC, press Side Door - [Unlock] on the [Regular Check] tab in the [Maintenance] menu.**
- 3 Taking the items below with you, move into the machine from the side door (Home).**
Cleaning cloth, clean stick, a container of maintenance liquid, lighting

4

Wipe the entire bottom of the image quality adjustment camera's cover.

Using a cleaning cloth moistened with maintenance liquid, wipe away ink, fluffy dust, and other dirt.



CAUTION:

Do not apply strong force to the shutter at the bottom of the cover.

The shutter may get bent and no longer close, causing ink to adhere to the camera and preventing further normal operation.

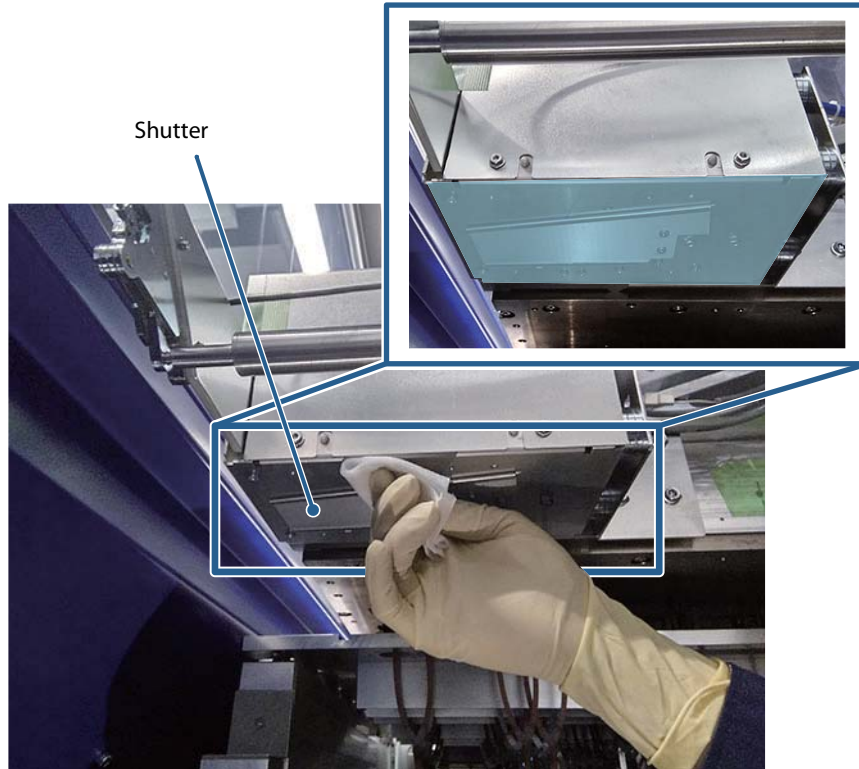

5 Open the shutter at the bottom of the cover. Then using a cleaning cloth moistened with maintenance liquid, wipe off dirt from the edges of the opening.

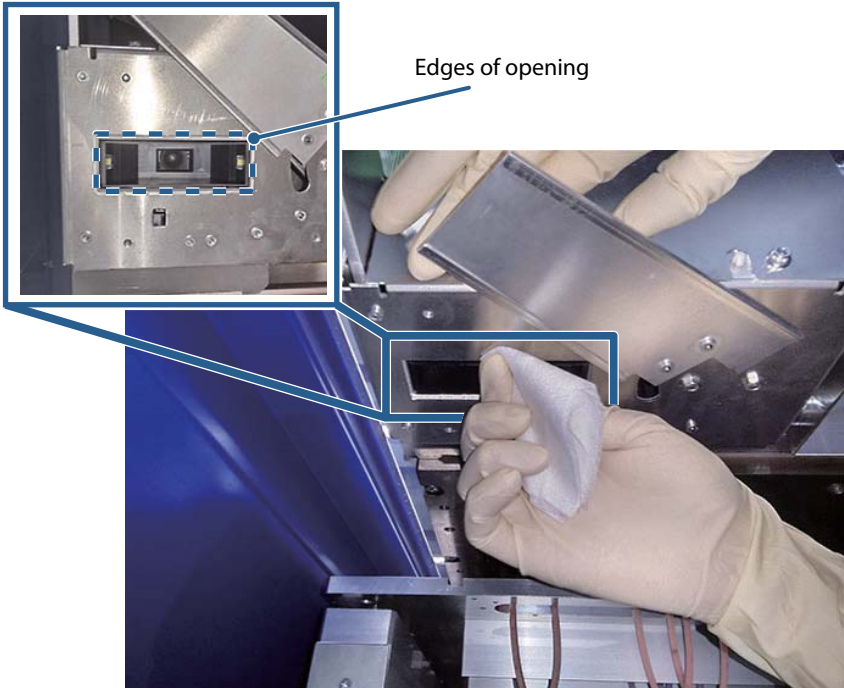

6 Using a clean stick moistened with maintenance liquid, wipe off dirt from the image quality adjustment camera's LEDs.

 **CAUTION:**
Do not touch the lens of the image quality adjustment camera.
The camera may no longer operate properly.

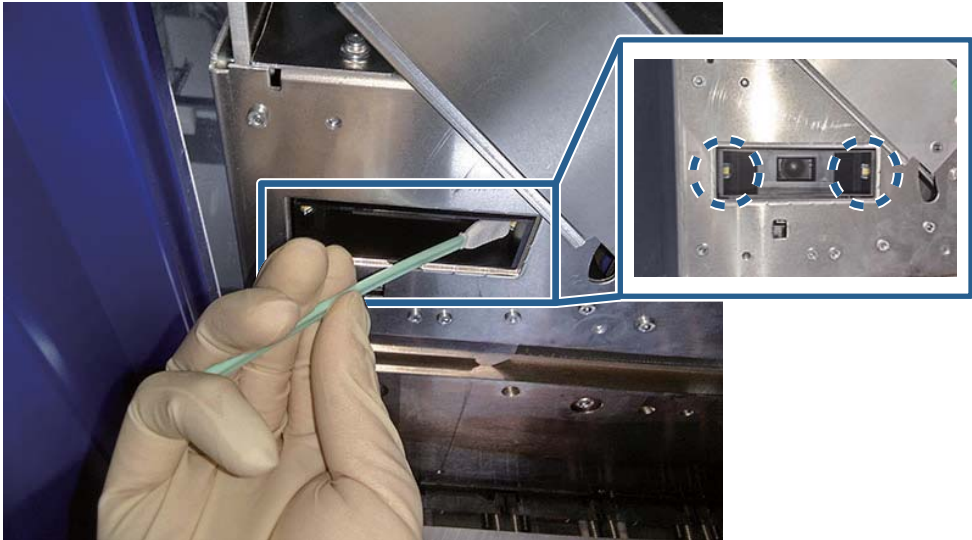

7 When cleaning is finished, close the shutter at the cover bottom.

Note:

Confirm that the shutter is securely closed.
If it is not securely closed, an error will occur when the machine operates.



8 Exit the machine from the side door (Home).

9 Make sure nobody is inside the machine, then close the side door and press the Confirm button.

10 On the screen of the control PC, press Side Door - [Lock] on the [Regular Check] tab in the [Maintenance] menu.

This completes the cleaning procedure.

Inspecting the Hinges on the Front Covers

The front cover hinges should be checked during daily inspections and replaced after the indicated number of years have passed.

Continuing to use this product without replacing the hinges could lead to injury if a front cover falls.

A message is displayed on the screen of the control PC when the number of years indicated for replacement have passed. Check the code number and part ID, and then contact your dealer or Epson Support.

- Replacement cycle: 10 years
- Number of hinges to replace: 9

Frequency	Everyday, inspection before beginning work
-----------	--

The front cover hinges should be checked during daily inspections and replaced after the indicated number of years have passed.

For more information on replacing the front cover hinges, refer to ["Regular Replacement Parts for Maintaining Safety" on page 16](#).

During the daily inspection, check the hinges on the front covers for damage.

If the hinges are damaged or there are any other abnormalities, such as unusual noise, contact your dealer or Epson Support.

1 Check the front covers (Home/Center/Full) for cracked or broken hinges (3 on each cover) and hinge pins.

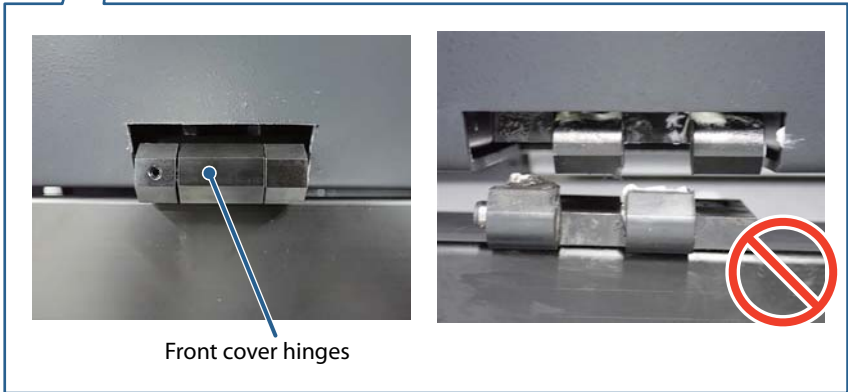

2 Confirm that the machine is in Standby status or Power Off status.

For more information about Standby status, refer to ["Standby Status"](#) on page 108.

For more information about Power Off status, refer to ["Power Off/Air Pressure Release Status"](#) on page 107.

3 Move the display of the control PC to the outer side.



4 Grab the handles, and slowly open the front covers in the following order: Home, Full, Center.

Make sure that they open smoothly, with no abnormal noise.

Note:

The front covers (Home and Full) must be opened first in order to open the front cover (Center).



- 5** Check the inside of the front covers (Home/Center/Full) for cracked or missing hinges (3 on each cover).



- 6** Check to see if the display of the control PC has been moved to the outer side. If it has not been moved, move the display of the control PC to the outer side.

- 7** Grab the handles, and slowly close the front covers in the following order: Center, Home, Full.

Make sure that they close smoothly, with no abnormal noise.

Note:

The front cover (Center) must be closed first in order to close the front covers (Home and Full).

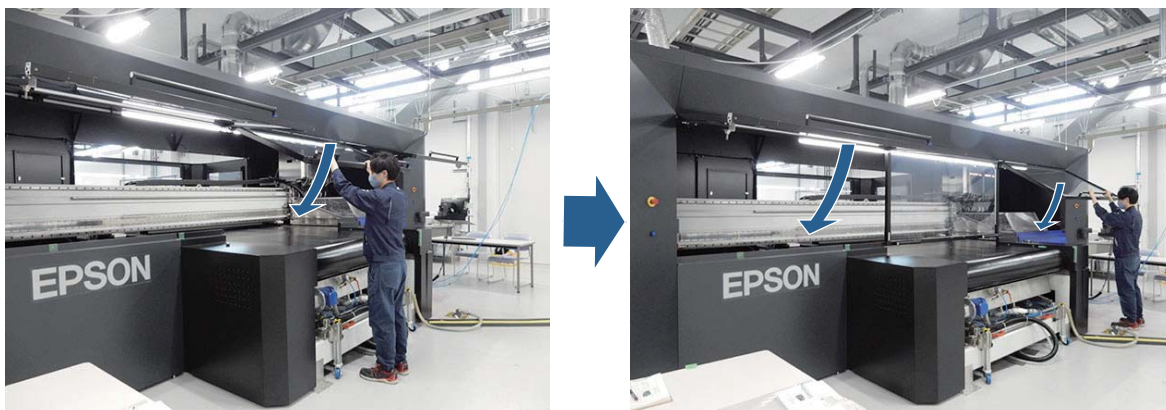

- 8** Return the control PC to its original position.

This completes the inspection.

Replacing Consumables

Replacing the Washing T-shaped Scraper

Frequency	When necessary
When to Replace	When the area in contact with the glue belt is worn/deteriorated. If the contacting area is worn/deteriorated, water cannot be wiped off completely after belt cleaning, resulting in water remaining on the belt.
Personal protective equipment	Protective gloves and clothing
Required items	Replacement washing T-shaped scraper, two belt cleaning unit wheels, hex key (width: 2.5 mm, 3 mm, 5 mm, 6 mm), spanner (width: 7 mm)

- 1** Confirm that the machine is in Power Off status. (See: "[Power Off/Air Pressure Release Status](#)")
- 2** Drain the water in the belt cleaning tank.
- 3** Turn the valve at the bottom to stop draining.
- 4** Remove each screw at the two locations that secure the belt cleaning unit.



- 5** Pull the belt cleaning tank toward you until the carriage rail hits the stopper nearest from you.



- 6** Use the hex key (width: 6 mm) to attach the belt cleaning unit wheels on the right and left sides.

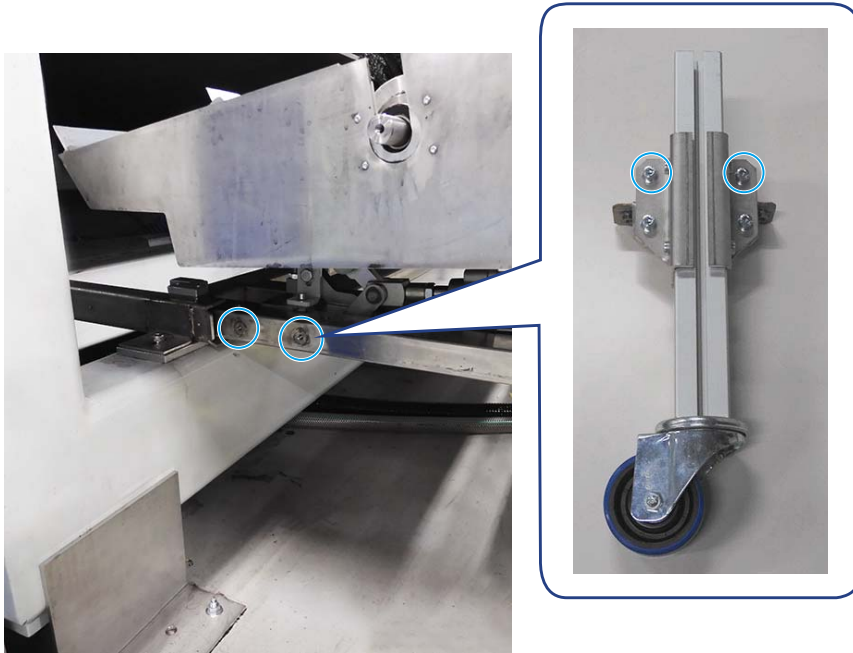

- 7** Use the hex key (width: 5 mm) to remove the stoppers on the right and left sides.

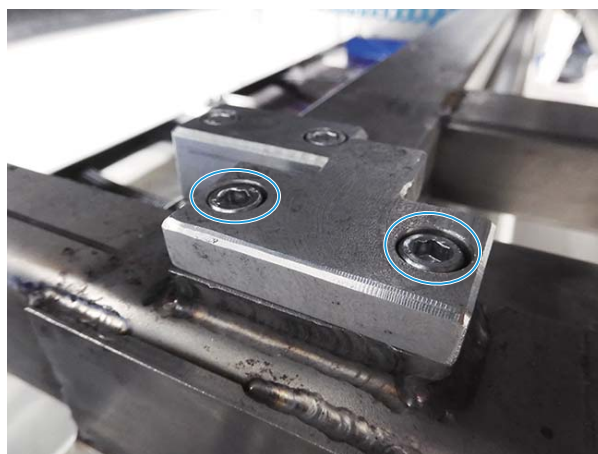

- 8** Pull the belt cleaning unit further toward you until it is completely out.
- 9** Remove the fixing plate that secures the washing T-shaped scraper to be replaced. Remove the screw and washer [1] on the fixing plate on the side to be pulled out using the spanner (width: 7 mm), and remove the fixing plate [2].



If waste ink is dried, apply maintenance liquid to dissolve the ink before cleaning.



10 Pull out the scraper.

If fluffy dust has become fused, remove it first as the scraper may be stuck when pulled out.

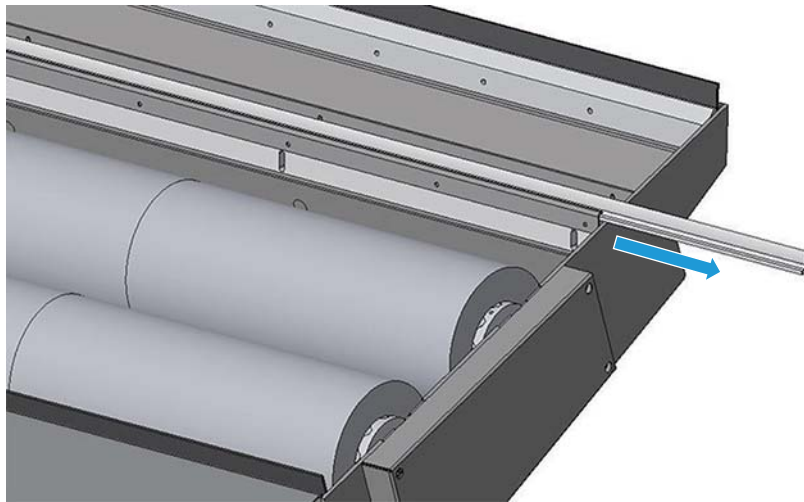

11 Insert a new scraper in the location where the scraper was pulled out.

12 Attach the fixing plate. Secure the screw, washer and fixing plate, using the spanner (width: 7 mm).

This completes the replacement procedure.

13 Return the belt cleaning unit to the original position.

Return the belt cleaning unit to the carriage rail. Attach the stopper and remove the belt cleaning unit wheels.

14 Push the belt cleaning unit to the original position. Then tighten the two screws by hand.



CAUTION:

When pushing the belt cleaning unit back to its original position, do not bend or twist the drain hose. If the drain hose gets bent or twisted, wastewater may back up and overflow from the cleaning tank.

15 Open the drain valve.

Replacing the Washing Silicone Scraper

Frequency	When necessary
When to Replace	When the area in contact with the glue belt is worn/deteriorated. If the contacting area is worn/deteriorated, water cannot be wiped off completely after belt cleaning, resulting in water remaining on the belt.
Personal protective equipment	Protective gloves and clothing
Required items	Replacement washing silicon scraper, two belt cleaning unit wheels, hex key (width: 4 mm, 6 mm)

- 1** Confirm that the machine is in Power Off status. (See: "[Power Off/Air Pressure Release Status](#)")
- 2** Pull out the belt cleaning unit.
Perform steps 1 to 5 in "Replacing the washing T-shaped scraper."
(See: "[Replacing the Washing T-shaped Scraper](#)")
- 3** Remove the washing silicone scraper to be replaced.
Loosen the 15 screws that secure the silicon scraper using the hex key (width: 4 mm).
- 4** Lift out the silicone scraper and attach a new silicone scraper.
- 5** Return the belt cleaning unit to the original position.
Perform steps 12 and 13 in "Replacing the washing T-shaped scraper."
(See: "[Replacing the Washing T-shaped Scraper](#)")

Replacing the Wiper

Frequency	When necessary/When a problem occurs
When to Replace	When the wiper is damaged When a message is displayed on the Control PC prompting you to replace the part
Personal protective equipment	Eye protection, protective gloves and clothing
Required items	Replacement wiper (consumable), hex key (width: 2.5 mm), ethanol, clean stick, cleaning wiper, plastic container



CAUTION:

Be sure to wear eye protection. Failure to do so could cause ink to splash into the eyes.

- 1 Confirm that the machine is in Standby status.**
For more information, refer to "[Standby Status](#)" on page 108.
- 2 On the screen of the control PC, press Head Maintenance - [Move to Full] on the [Regular Check] tab in the [Maintenance] menu.**
The print heads move to the Full side. The side doors unlock.
- 3 Move the display of the control PC to the outer side.**



- 4 Open the front cover (Home).**
- 5 Open the maintenance cover beside the belt on the Home side, and align it with the maintenance cover below the front cover.**
- 6 Grab the handle of the maintenance cover below the front cover and slowly open the maintenance cover.**

- 7 While pulling the knob of the stopper on the cleaning station toward you with your left hand, use your right hand to slightly pull out the cleaning station.
- 8 Grab the handle on the cleaning station and slowly pull it out toward you.
- 9 Move into the machine from the side door (Home).
- 10 Loosen the center screw that secures the wiper to be replaced with the hex key (width: 2.5 mm) and remove the wiper.

**CAUTION:**

Make sure that the machine's power is off before performing work.

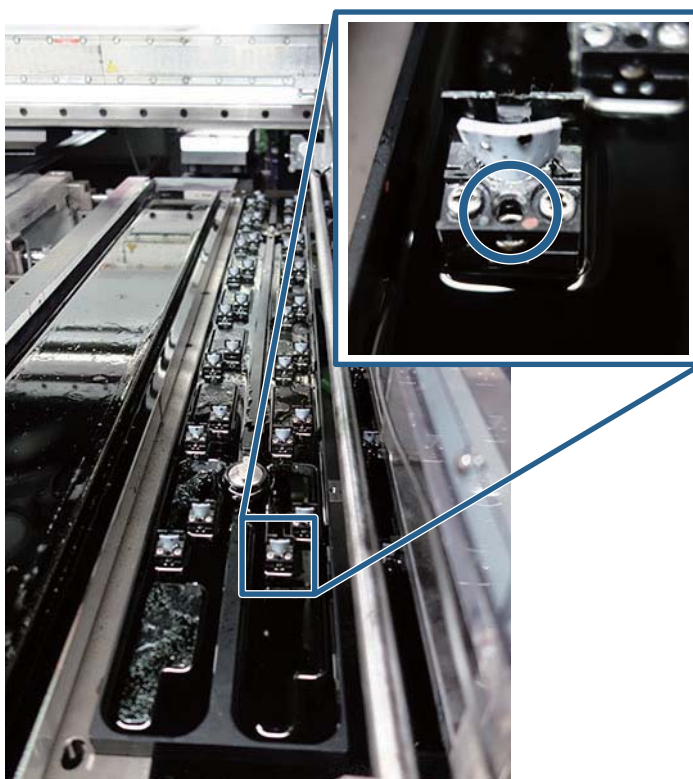

11 Wipe any dirt from the location where the wiper was removed using the cleaning cloth or clean stick moistened with maintenance liquid.

12 Insert the pin at the installation position into the hole on the bottom surface of the new wiper.

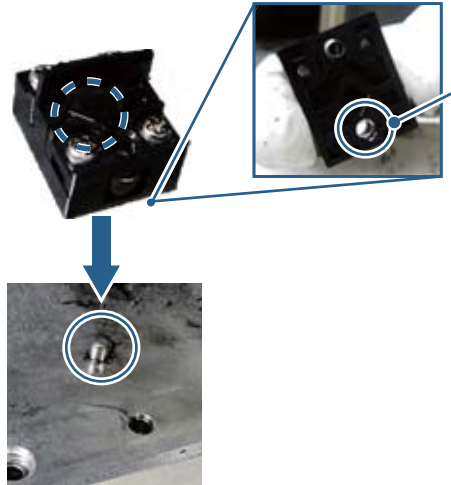

13 Tighten the screw on the wiper with the hex key (width: 2.5 mm).



CAUTION:

Do not pull the rubber part of the wipers.

When attaching the wiper, make sure that it is installed in the proper position and direction.



14 Check the surface of the rubber for any grease that has oozed out and dirt.

If grease has oozed out or if there is dirt on the rubber surface, wipe the wiper rubber section gently using the clean stick moistened with ethanol.

**15 Make sure that no tools or other items are left on the print head operating area.****16 When cleaning is finished, move out of the machine from the side door.****17 Return the cleaning station.**

Grabbing the cleaning station's handle and being careful not to pinch any cables, slowly push it back into its original position until you hear the stopper click into place.

18 Slowly close the maintenance cover below the front cover.**19 Return the maintenance cover beside the belt (on the Home side) to its original position.****20 Check to see if the display of the control PC has been moved to the outer side.****21 Close the front cover (Home).****22 Return the control PC to its original position.****23 Make sure nobody is inside the machine, then close the side door and press the Confirm button.****24 On the screen of the control PC, press [Capping].**

The print heads move to the Home side. The side doors lock.

This completes the work.

Replacing the ink tubes for the pump

Frequency	When necessary
When to Replace	When the ink tube is torn or otherwise damaged When a message is displayed on the Control PC prompting you to replace the part
Personal protective equipment	Eye protection, protective gloves and clothing
Required items	Replacement ink tubes

- 1 Confirm that the machine is in Standby status.**
- 2 When replacing the ink tubes for the pump on the front, press Side Door - [Unlock] on the [Regular Check] tab in the [Maintenance] menu on the screen of the control PC. When replacing the ink tubes for the pump on the rear, press [Head Maintenance] - [Move to Full].**
The side doors unlock. When you press [Move to Full], the print heads move to the Full side.
- 3 Move the display of the control PC to the outer side.**



- 4 Open the front cover (Home).**
- 5 Open the maintenance cover beside the belt on the Home side, and align it with the maintenance cover below the front cover.**
- 6 Grab the handle of the maintenance cover below the front cover and slowly open the maintenance cover.**
When replacing the ink tubes for the pump on the front, refer to Procedure 10.
- 7 While pulling the knob of the stopper on the cleaning station toward you with your left hand, use your right hand to slightly pull out the cleaning station.**

- 8 Grab the handle on the cleaning station and slowly pull it out toward you.
- 9 Move into the machine from the side door (Home).
- 10 Remove the cover from the ink tubes to be replaced.
Grip the side of the cover of the ink tubes to be replaced, and pull it straight toward you.

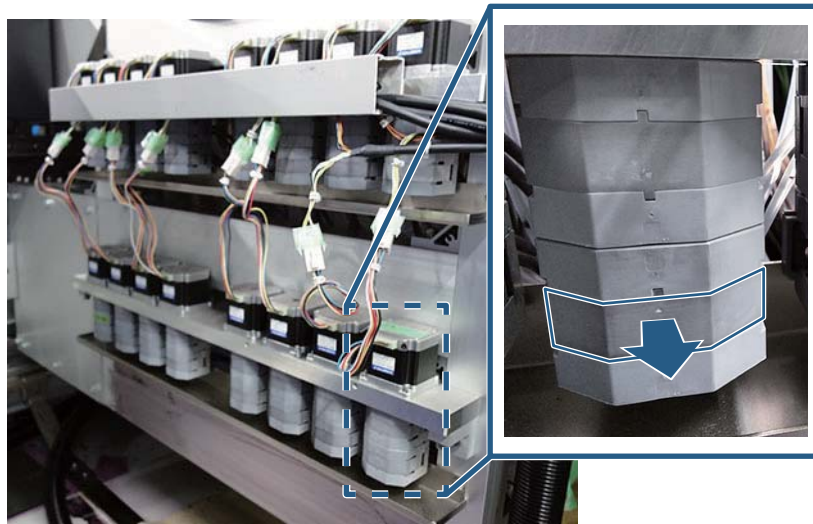

- 11 Pull the ink tubes (4 tubes on each) at the rear of the pump straight out.

**CAUTION:**

Ink may have stuck to the ink tubes.
Do not tilt the ink tubes or touch them.

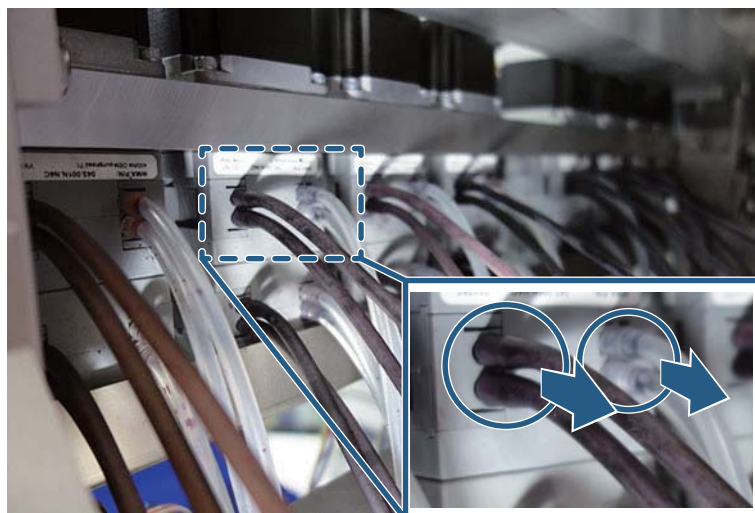

12 Remove the tube holder on the right side of the pump by pulling it straight out to the right.

In the same way, remove the tube holder on the left side of the pump by pulling it straight out to the left.

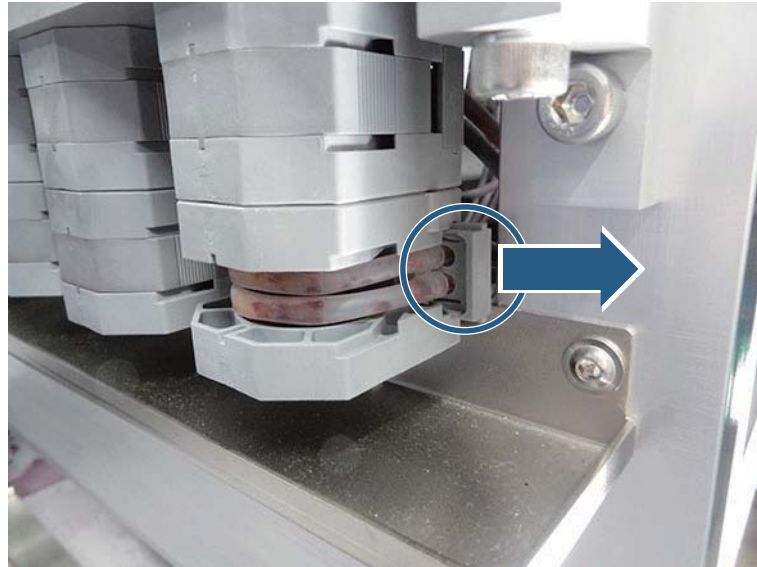

13 Remove the ink tubes to be replaced from the tube holder.



CAUTION:

Ink may have stuck to the ink tubes.
Do not tilt the ink tubes or touch them.



14 Replace with new ink tubes.

15 Attach the new ink tubes to the tube holder.



16 Insert the tube holder on the right side of the pump straight and push it to the left.
In the same way, insert the tube holder on the left side of the pump straight and push it to the right.

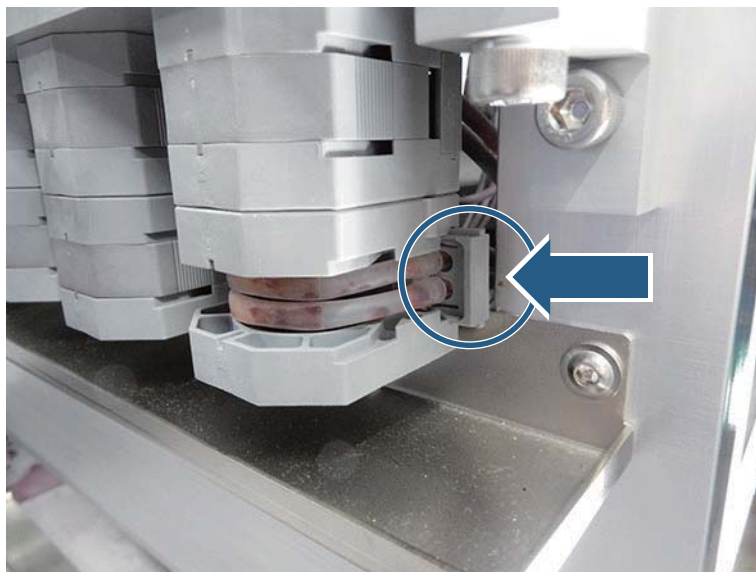

17 Insert the ink tube that was removed in step Procedure 11 into the new ink tube.

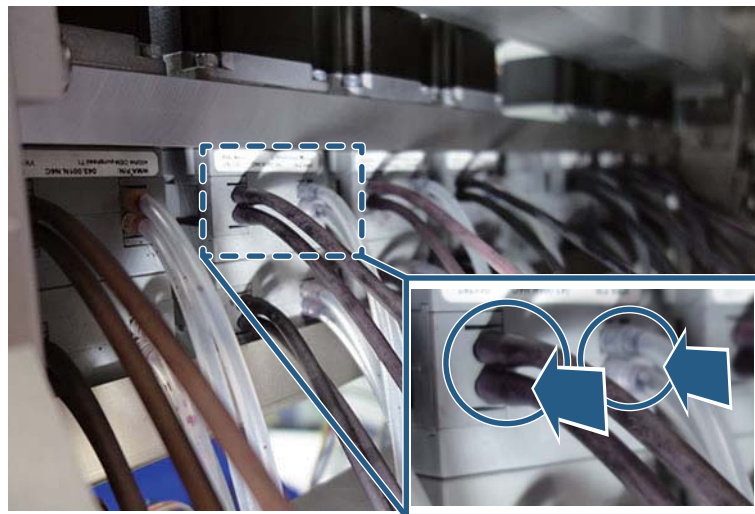

18 Attach the cover to the ink tubes that were replaced.

Grip the side of the cover of the ink tubes being replaced, and insert it straight until it clicks into place.

When replacing the ink tubes for the pump on the front, refer to Procedure 21.

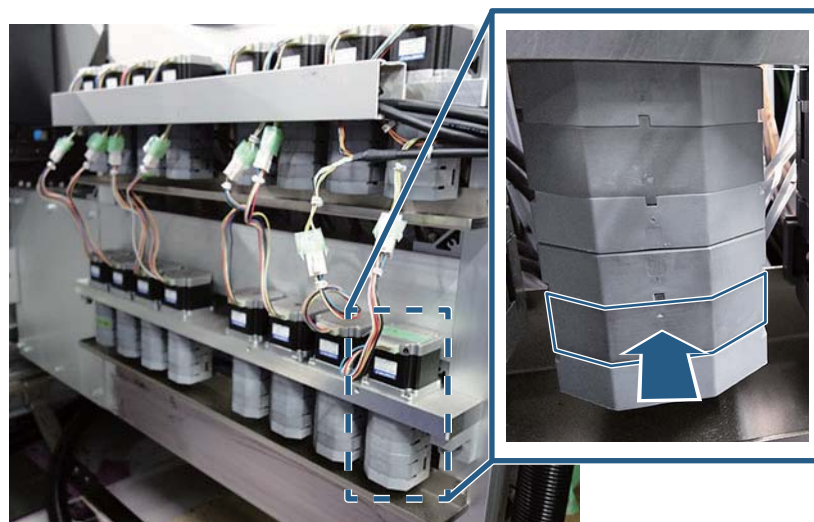

19 When replacements are finished, move out of the machine from the side door.

20 Return the cleaning station.

Grabbing the cleaning station's handle and being careful not to pinch any cables, slowly push it back into its original position until you hear the stopper click into place.

21 Slowly close the maintenance cover below the front cover.

- 22** Return the maintenance cover beside the belt (on the Home side) to its original position.
- 23** Check to see if the display of the control PC has been moved to the outer side.
If it has not been moved, move the display of the control PC to the outer side.
- 24** Close the front cover (Home).
- 25** Return the control PC to its original position.
When replacing the ink tubes for the pump on the front, refer to Procedure 27.
- 26** Make sure nobody is inside the machine, then close the side door and press the Confirm button.
- 27** When you have replaced the ink tubes for the pump on the front, press [Side Door] - [Lock] on the screen of the control PC.
When you have replaced the ink tubes for the pump at the rear, press [Capping] on the screen of the control PC.
The side doors unlock. When you press [Capping], the print heads are capped.

This completes the work.

Replacing the Cap Unit

Frequency	When necessary/When a problem occurs
When to Replace	When clogged nozzles are not resolved by cleaning
Personal protective equipment	Eye protection, protective gloves and clothing
Required items	Replacement cap unit (consumable), forceps, hex key (width: 2.5 mm), maintenance liquid, clean stick, plastic container



CAUTION:

Be sure to wear eye protection. Failure to do so could cause ink to splash into the eyes.

- 1** Confirm that the machine is in Standby status. (See: [Standby Status](#))
- 2** On the screen of the control PC, press Head Maintenance - [Move to Full] on the [Regular Check] tab in the [Maintenance] menu.
The print heads move to the Full side. The side doors unlock.
- 3** Move the display of the control PC to the outer side.



- 4** Open the front cover (Home).

- 5** Open the maintenance cover beside the belt on the Home side, and align it with the maintenance cover below the front cover.

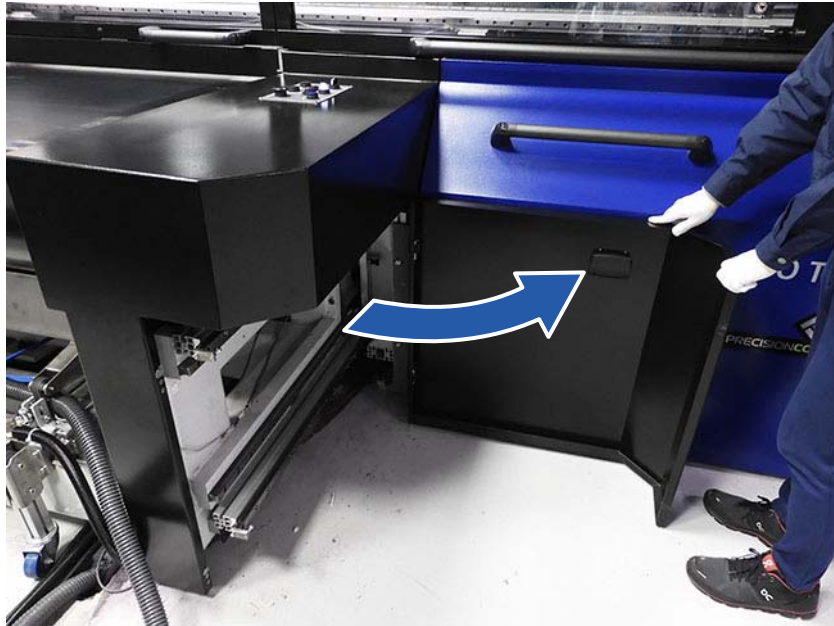

- 6** Grab the handle of the maintenance cover below the front cover and slowly open the maintenance cover.



- 7** While pulling the knob of the stopper on the cleaning station toward you with your left hand, use your right hand to slightly pull out the cleaning station.



8 Grab the handle on the cleaning station and slowly pull it out toward you.

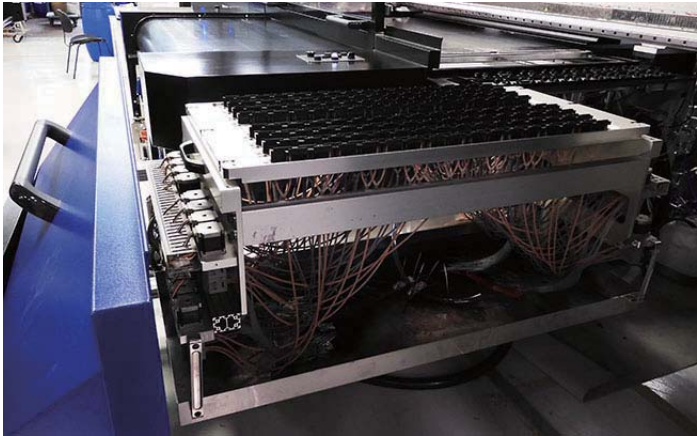

9 A cap unit is equipped with four caps.
Loosen the screw at the center of the cap unit with the hex key (width: 2.5 mm).



- 10** While taking care not to let the springs fall out, lift the cap upward keeping it horizontal.



- 11** Hold the ink tubes with the forceps.

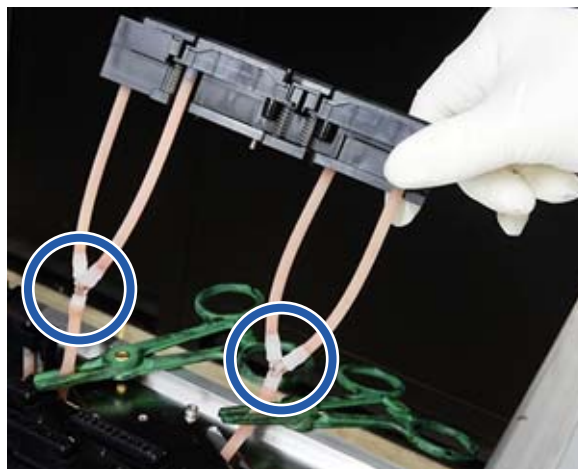

- 12** Pull out the ink tubes at the locations indicated by circles.
Be careful of splashing ink.

- 13** Insert tubes into a new cap unit.
Insert the tubes securely as far as possible.



CAUTION:

Do not touch the lip surface of the cap.

- 14** Remove the forceps from the ink tubes.

- 15** Attach the cap unit.
Make sure that all springs are installed.
Make sure that the cap is set horizontally.

- 16** While wearing rubber gloves, use your finger to push the lip of the cap in and see if it returns.



- 17** Secure the cap unit by tightening the screw at the center with the hex key (width: 2.5 mm).

- 18** Grease may have oozed out of the surface of the lip section.

Wipe the lip section gently using the clean stick moistened with maintenance liquid.



Wipe off the maintenance liquid from the surface of the cap.

- 19** After replacement, make sure that no tools or other items are left on the print head operating area or carriage operating area.

- 20** Return the cleaning station.

Grabbing the cleaning station's handle and being careful not to pinch any cables, slowly push it back into its original position until you hear the stopper click into place.

- 21** Slowly close the maintenance cover below the front cover.

- 22** Return the maintenance cover beside the belt (on the Home side) to its original position.

- 23** Check to see if the display of the control PC has been moved to the outer side.
If it has not been moved, move the display of the control PC to the outer side.

- 24** Close the front cover (Home).

- 25** Return the control PC to its original position.

26 On the screen of the control PC, press [Capping].
The print heads move to the Home side. The side doors lock.

This completes the work.

Other Maintenance

Applying anti-foaming agent to the belt cleaning unit (only when using acid ink)

If you use acid ink, foam may be generated in the belt cleaning unit and the cleaning tank may overflow. Follow the steps below to apply anti-foaming agent to the belt cleaning unit.

Frequency	Apply once every two days before beginning work. However, apply as needed when ink sticks to the belt and foams. Ink is especially prone to foaming after the following operations. <ul style="list-style-type: none"> • When printing on fabrics that are prone to ink bleed-through • When printing at a print width of 1500 mm or more • When printing at print length of 3700 m or more
Required Items	Personal protective equipment (protective gloves and clothing, eye protection), wipe cloths, plastic containers, anti-foaming agent, and brushes

- 1 Check that the machine is off.**
For more information, refer to ["Power Off/Air Pressure Release Status"](#) on page 107.
- 2 Remove each screw at the two locations that secure the belt cleaning unit.**



- 3** Pull the belt cleaning unit toward you until the carriage rail hits the stopper nearest from you.



- 4** Use a wipe cloth to wipe off any water droplets on the metal parts that hold the scraper in place and the metal parts inside both sides of the belt cleaning tank.

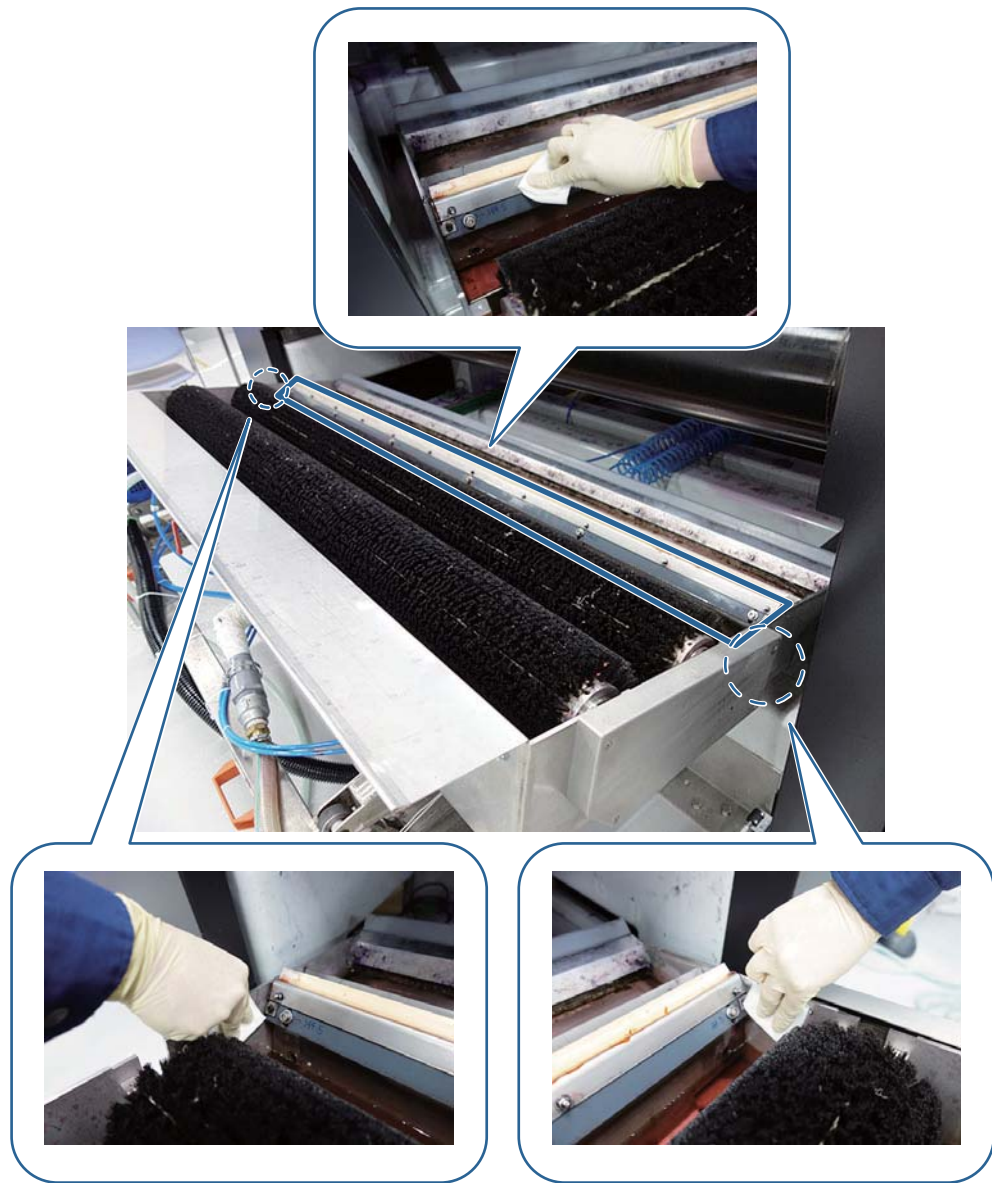

- 5** Pour approximately 20 g of anti-foaming agent into a plastic cup.

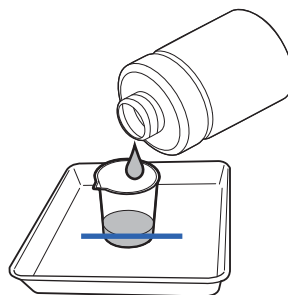

-
- 6** Apply anti-foaming agent to a brush and then apply it to the metal parts that hold the scraper in place and the metal parts inside both sides of the belt cleaning tank. Evenly apply the entire contents of the plastic cup.

Note:

Apply the anti-foaming agent so that it does not adhere to the brush or the cleaning scraper. If any adheres to these items, wipe it off with a wipe cloth moistened with alcohol.

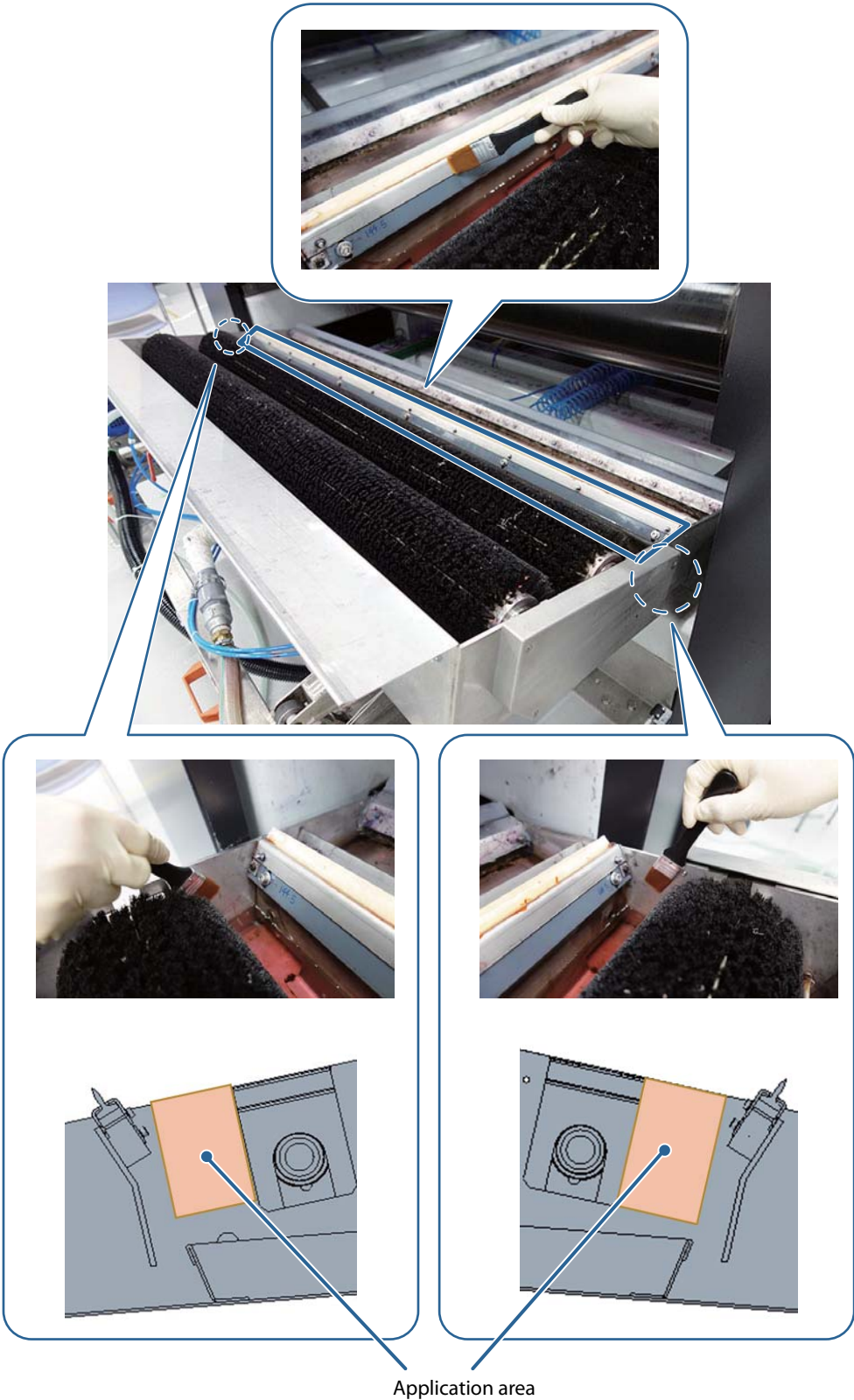





Application area

Glue Removal







To remove glue, first pour the remover from the rear of the machine to dissolve the glue, and then scrape glue away from the front of the machine.

This section describes the procedures for using the glue remover recommended by Epson.

When applying a top coating without removing glue, see ["Glue Application" on page 212](#).

Frequency	When the fabric attached to the belt rises slightly. When there is damage such as peeling of the glue.	
Required number of workers	Min. 2 people	
Personal protective equipment	The following is the protective equipment that must be worn when using the glue or glue remover recommended by Epson. For details, refer to the instructions of the SDS for the glue and glue remover you are actually using.	
	Eye protection (For organic solvent use; Optimal is a goggle-type that seals against your face)	
		
	Gas mask (for organic solvent use)	
		
Protective gloves (butyl or polyurethane)		
		
Protective clothing (long-sleeved)		
Hat or hair net (People with long hair must tie their hair and also wear a hair net.)		







Required Items	Item	Quantity	Details
	Blade supports 	2	
	Felt rod 	1	
	Glue collection bucket 	1	
	Glue-removal felt 	1 sheet	Use the following felt size: 190 (width) x 45 (length) cm
	Glue remover 	10 to 20 L	Glue remover Recommended product <ul style="list-style-type: none"> • Cleanser TS (Murayama Chemical Laboratory) • ATR1222 (ATR) • ATR3222 (ATR)
	Ethanol	1 L	Commercially available

Required Items	Item	Quantity	Details
	Bottle (for ethanol) 	1	Commercially available
	Hex key 	1 set	Commercially available
	Spanner (width: 13 mm) 	1	Commercially available
	Wipe cloths (for wiping the belt; soft non-fluffy material that will not damage the belt) 	Proper amount	Commercially available
	Bucket for glue remover 	1	Commercially available
	Cable ties	Approx. 4	Commercially available
	Rubber or plastic spatula (material that does not dissolve in organic solvents) 	1	Commercially available

Required Items	Item	Quantity	Details
	Bags or plastic sheets (material that does not dissolve in organic solvents)	Proper amount	Commercially available, for curing Approx. 1.9 m (width) x 2 m or more (length) Thickness: 1 mm or less Used to protect the belt cleaning unit.



CAUTION

	   	<p>Wear eye protection, protective gloves, protective clothing, and respiratory protection when performing these procedures.</p> <p>For details, refer to the instructions on the Safety Data Sheet (SDS) for the glue and glue remover that you are actually using, and be sure to use the required protective equipment.</p>
		<p>Wear a hat so that your hair does not fall onto the belt.</p> <p>Long hair should be tied back and worn under a hair net.</p>

Preparation

1 Confirm that the machine is in Standby status.

For more information, refer to ["Standby Status" on page 108](#).

2 From the control PC, open the [Print] menu and confirm that [Print Settings] - [Device Settings] - [Belt Cleaning] and [Pressure Roller] are not selected (1) or are grayed out (2).

If [Belt Cleaning] and [Pressure Roller] are not grayed out and are selected, unselect [Belt Cleaning] and [Pressure Roller], or select [Cut Sheet Mode].

Belt cleaning and the pressure roller will no longer operate even if the feed button is pressed.

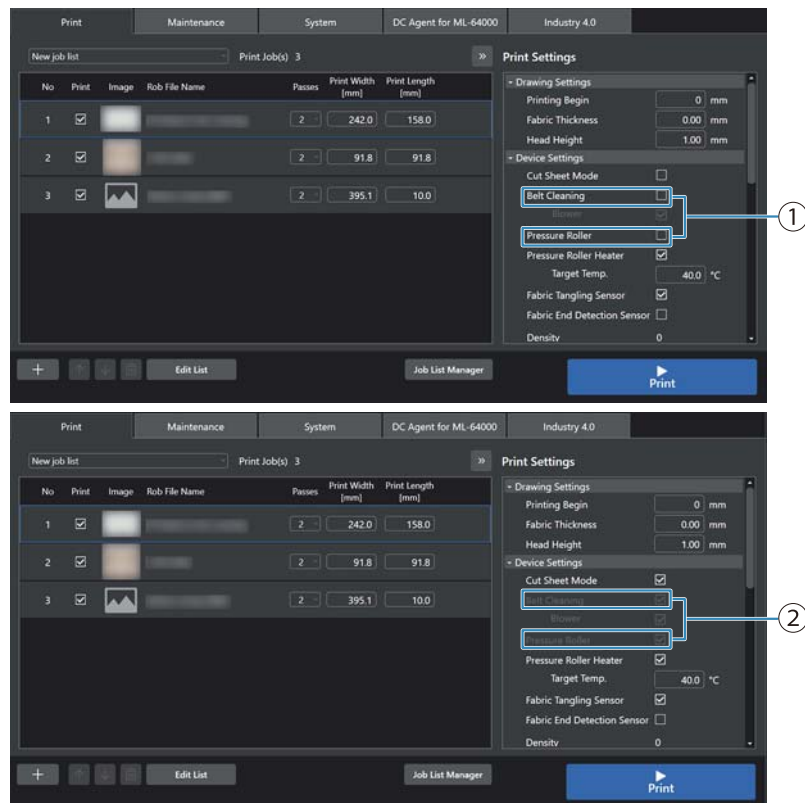

- 3** Remove each screw at the two locations that secure the belt cleaning unit.



- 4** Pull the belt cleaning unit toward you until the carriage rail hits the stopper nearest from you.



- 5** Cover the belt cleaning unit with plastic sheet, spread out the wrinkles in the plastic, and then tape it down.

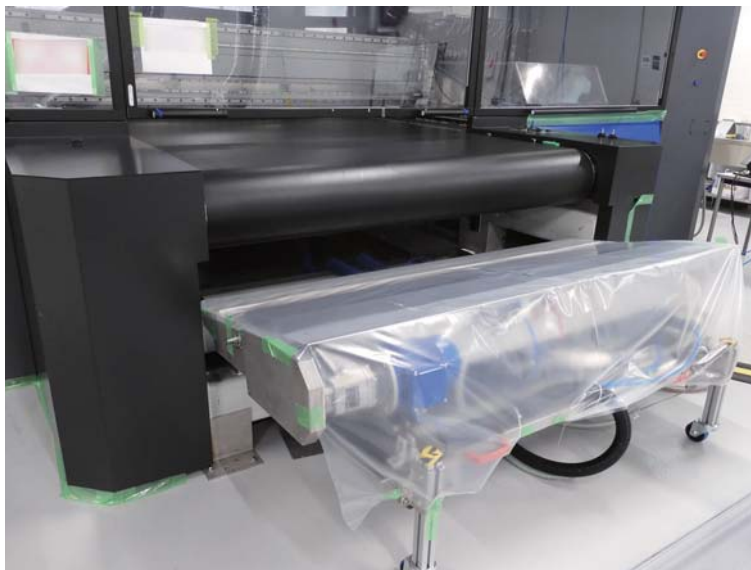

- 6** Push the belt cleaning unit back.



- 7** Turn the machine to Power Off status.
For more information, refer to ["Power Off/Air Pressure Release Status"](#) on page 107.

8 Two people are required to remove the fabric roll.



WARNING:

Since the fabric roll is heavy, be sure to have at least two workers remove and install it. When lifting the fabric roll, make sure you bend your knees sufficiently and lift in a natural position.



9 Remove the tension roller cover. Remove the tension roller cover screws (4 each on Home side and Full side) using the hex key (width: 3 mm).

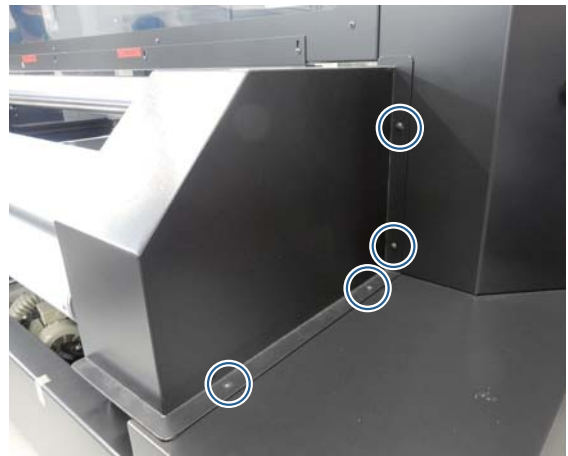

10 Disconnect the tension roller connector from the electromagnetic brake connector.

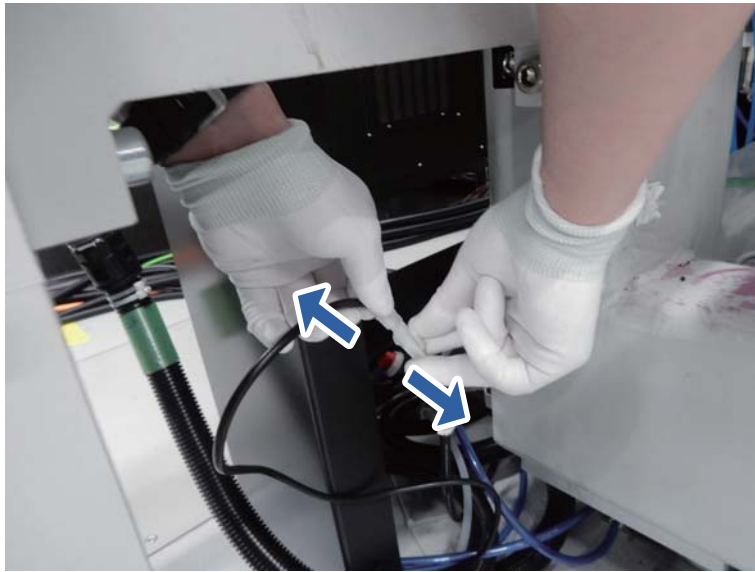

11 Remove the tension roller unit. This single unit consists of three rollers: roller 1, the tension roller, and roller 2.

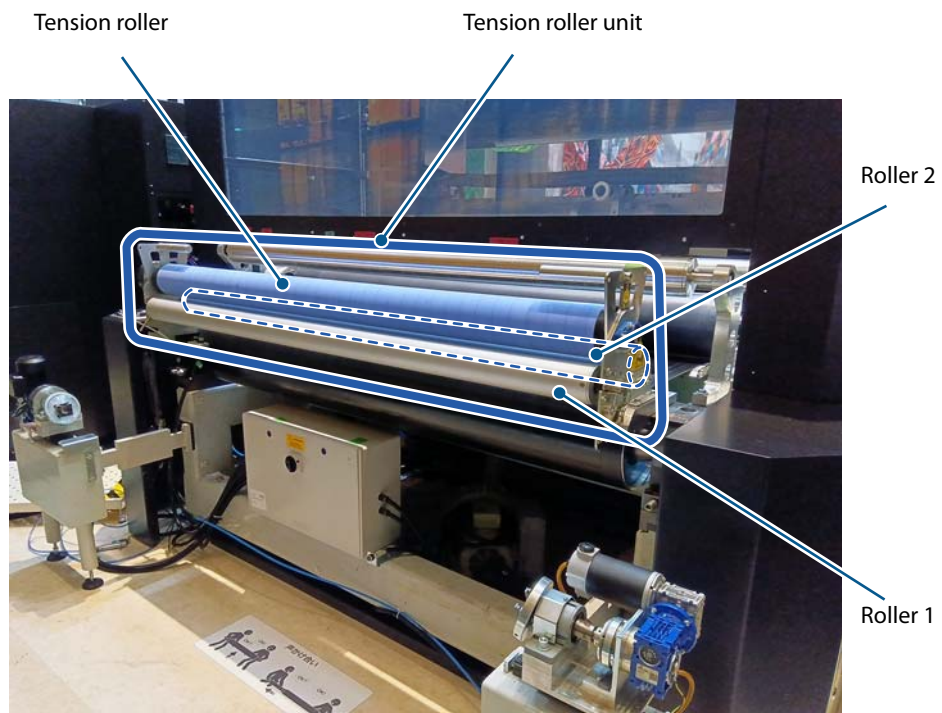

The unit weighs 52 kg. Roller 1 weighs 10 kg.

To reduce the weight, you can also remove roller 1 before removing the unit.

Start from the next procedure (Step 12).

When removing the unit with roller 1 still attached, start from Step 14.

12 Remove the fixing pins on both sides of roller 1.



Remove the hook from the pin tip and then pull the pin out upward.

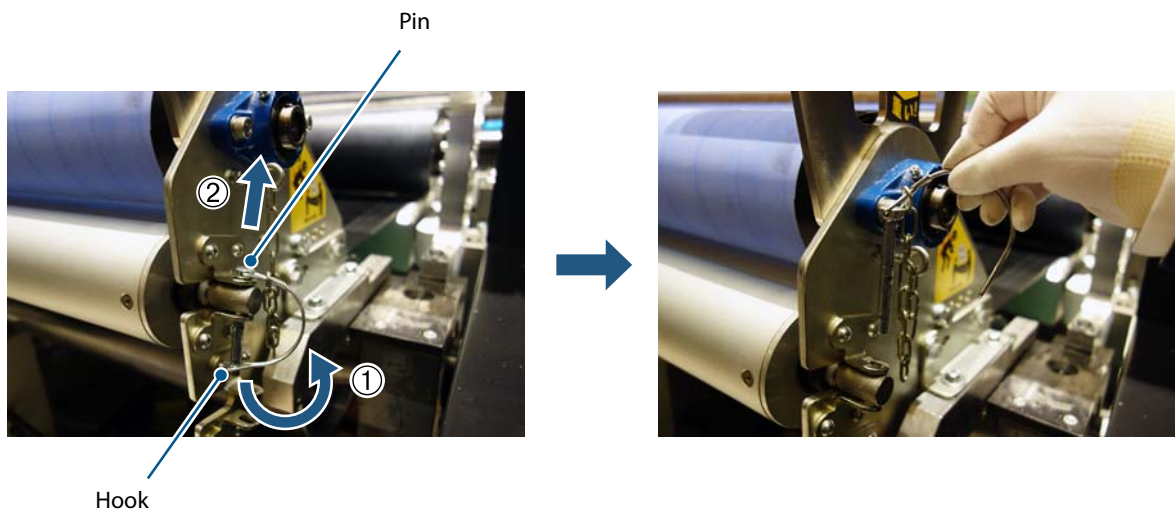

13 With two workers, remove roller 1.



CAUTION:

Be sure to have at least two workers remove and install the roller.
When lifting the roller, make sure you bend your knees sufficiently and lift in a natural position.



14 Remove the screws on each side of the tension roller unit (2 each) using the spanner (width: 13 mm).

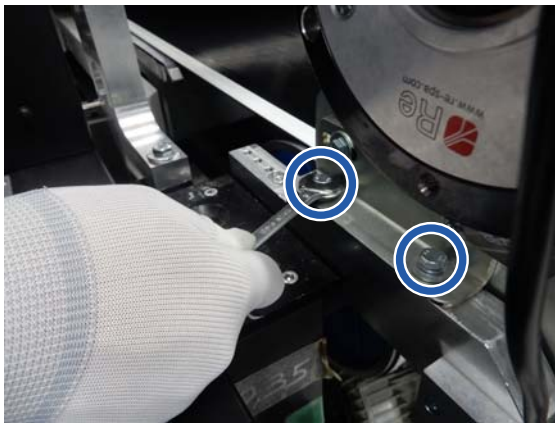

15 With two workers, remove the tension roller unit.



CAUTION:

Be sure to have at least two workers remove and install the unit.
When lifting the unit, make sure you bend your knees sufficiently and lift in a natural position.



16 Move to the rear of the machine, and install the blade supports on the right and left. Install next to the belt and tighten the screws (1 each on Home side and Full side) using the hex key (width: 5 mm).



17 Attach the felt to the felt rod.



When using commercially available felt:

Sew the ends into bag shapes to make mounting holes, or use cable ties to secure the felt in place after wrapping the felt around the felt rod.

Example: Securing the felt with cable ties

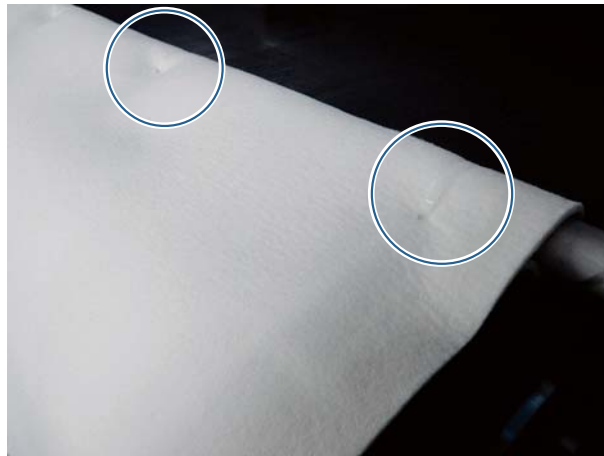

18 Place the felt rod on the belt.



19 Secure the felt rod and blade supports with cable ties.

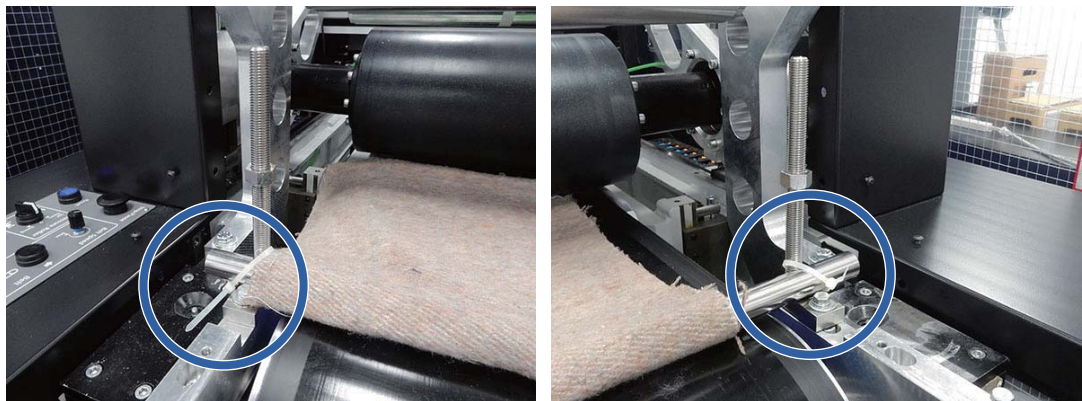

Removal of Glue

- 1 Turn the main power switch to 1 (ON) to turn the power on.
- 2 On the control PC, select [Belt Speed Volume Switch] on the [Belt] tab. Select this to enable adjustment of the belt speed volume on the rear panel.

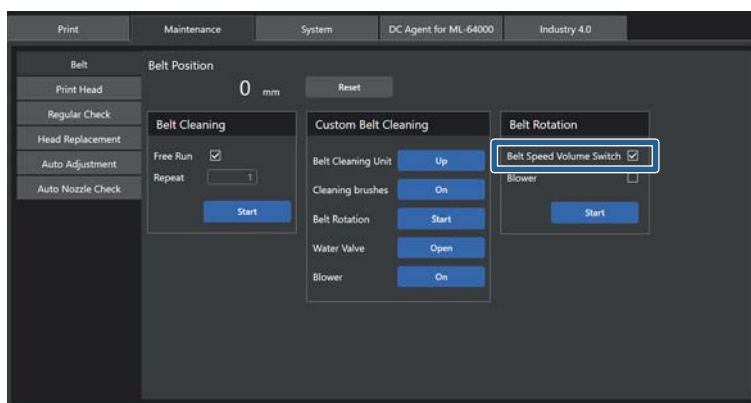

- 3 Pour the glue remover into the glue remover bucket.



WARNING:

When using the glue remover, wear the personal protective equipment for organic solvent use, such as protective gloves, eye protection, and respiratory protection.

- 4 Soak the felt with an appropriate amount of glue remover (approx. 2 L).
Worker 1 (at the rear side of the machine): Soak the felt a little at a time so that the remover completely permeates the felt.



- 5** Adjust the belt speed volume to a speed that is easy to work with.
Aim for a speed that is in the range shown by the arrows in the figure.



- 6** Gradually soak the felt with the glue remover until it is uniformly spread.
- 7** The glue on the belt surface begins to dissolve.
Make sure that the glue becomes loose and rises slightly along the entire belt.
- 8** Start performing glue removal work.
Worker 2: Take the glue collection basket and move to the front side of the machine.
- 9** Remove the glue from all areas of the belt.
Worker 1 (at the rear side of the machine): To prevent the glue remover on the surface of the belt from drying, soak the entire surface of the felt with more glue remover.
Worker 2 (at the front side of the machine): Securely grasp the handles of the glue collection basket with both hands and press it against the belt surface to scrape away the glue.



Pressing a glue bucket forcefully can damage the belt surface.



10 Worker 2 (at the front side of the machine): Once most of the glue has been scraped away, gradually move to the left while scraping away glue from all areas of the belt.

Worker 1 (at the rear side of the machine): While checking the scraping conditions, continue pouring an appropriate amount of remover onto the felt.

11 After scraping away the glue, if there are any areas with hardened glue remaining, stop the belt and use a wipe cloth to remove it. If the hardened glue cannot be easily removed, use the felt moistened with remover to make the hardened glue rise again, and then scrape it away.



12 When all glue has been removed, remove the felt. Dispose of the felt in the proper manner for industrial waste.

Belt Surface Wiping

- 1** Use a wipe cloth soaked in ethanol (proper amount) to wipe the belt surface.
- 2** Adjust the belt speed volume to a speed that is easy to work with.
Aim for a speed that is in the range shown by the arrows in the figure.



- 3** Wipe it clean using an ethanol-soaked wipe cloth.



Wipe off the glue until the belt surface has a luster. Be especially careful to remove the glue from both edges of the belt.



Work after Removal

- 1** Move to the front side of the machine, and pull out the belt cleaning tank.
- 2** Remove the protection material (bags or plastic sheets) from the belt cleaning tank. If there is any organic solvent adhered to the protection material, dispose of the protection material in the proper manner for industrial waste.
- 3** Push the belt cleaning unit to the original position. Then tighten the two screws by hand.

**CAUTION:**

When pushing the belt cleaning unit back to its original position, do not bend or twist the drain hose. If the drain hose gets bent or twisted, wastewater may back up and overflow from the cleaning tank.



Cleanup





Use wipe cloths or similar to absorb any waste chemicals, and then dispose of them in the proper manner for industrial waste.





Next, apply glue.









Glue Application

Glue application work is performed at the rear of the machine.

Frequency	When the fabric attached to the belt rises slightly. When there is damage such as peeling of the glue.	
Required number of workers	Min. 2 people	
Personal protective equipment	The following is the protective equipment that must be worn when using the glue or glue remover recommended by Epson. For details, refer to the instructions of the SDS for the glue and glue remover you are actually using.	
	Eye protection (For organic solvent use; Optimal is a goggle-type that seals against your face)	
		
	Gas mask (for organic solvent use)	
		
Protective gloves (butyl or polyurethane)		
Protective clothing (long-sleeved)		
Hat or hair net (People with long hair must tie their hair and also wear a hair net.)		

Required Items	Item	Quantity	Details
	Blade supports 	2	Bundled item
	Blade 	1	
	Glue application blocks 	2	Bundled item
	Bucket for glue 	2	Commercially available
	Scale	1	Commercially available
	Scissors	1	Commercially available
	Stirring rod for preparing glue	1	Commercially available
	Hex key 	1 set	Commercially available
	Glue A Recommended product <ul style="list-style-type: none"> • ATR1717 • ATR1719 	2.5 kg	This is the quantity of glue to apply if existing glue is removed first.
		1.4 kg	This is the quantity of glue to apply on top if existing glue is not removed first.

Required Items	Item	Quantity	Details
	Glue B Recommended product <ul style="list-style-type: none"> • ATR1642 • ATR1655 	0.5 kg	This is the quantity of glue to apply if existing glue is removed first.
		0.8 kg	This is the quantity of glue to apply on top if existing glue is not removed first.
	Ethanol	1 L	Commercially available
	Bottle (for ethanol) 	1	Commercially available
	Insulating tape (thickness: 0.15 to 0.2 mm) Recommended: 0.2 mm (thickness) x approx. 19 mm (width) x 10 m (length) 	2	Commercially available When applying glue, be sure to use tape with a thickness of 0.15 to 0.2 mm, because this will be the gap between the blade and belt.
	Soapy water	Proper amount	Commercially available
	Bottle (for soapy water) 	1	Commercially available
	Wipe cloths (for wiping the belt; soft non-fluffy material that will not damage the belt) 	Proper amount	Commercially available

 CAUTION		
		Wear eye protection, protective gloves, protective clothing, and respiratory protection when performing these procedures.
		For details, refer to the instructions on the Safety Data Sheet (SDS) for the glue and glue remover that you are actually using, and be sure to use the required protective equipment.
		When applying glue, there is a risk of inhaling harmful vapors released by the glue or of the glue adhering to your skin.
		Be sure to wear appropriate personal protective equipment and to ventilate the work environment.
		Wear a hat so that your hair does not fall onto the belt.
		Long hair should be tied back and worn under a hair net.

Preparation

- 1 From the control PC, open the [Print] menu and confirm that [Print Settings] - [Device Settings] - [Belt Cleaning] and [Pressure Roller] are not selected (1) or are grayed out (2).

If [Belt Cleaning] and [Pressure Roller] are not grayed out and are selected, unselect [Belt Cleaning] and [Pressure Roller], or select [Cut Sheet Mode].

Belt cleaning and the pressure roller will no longer operate even if the feed button is pressed.

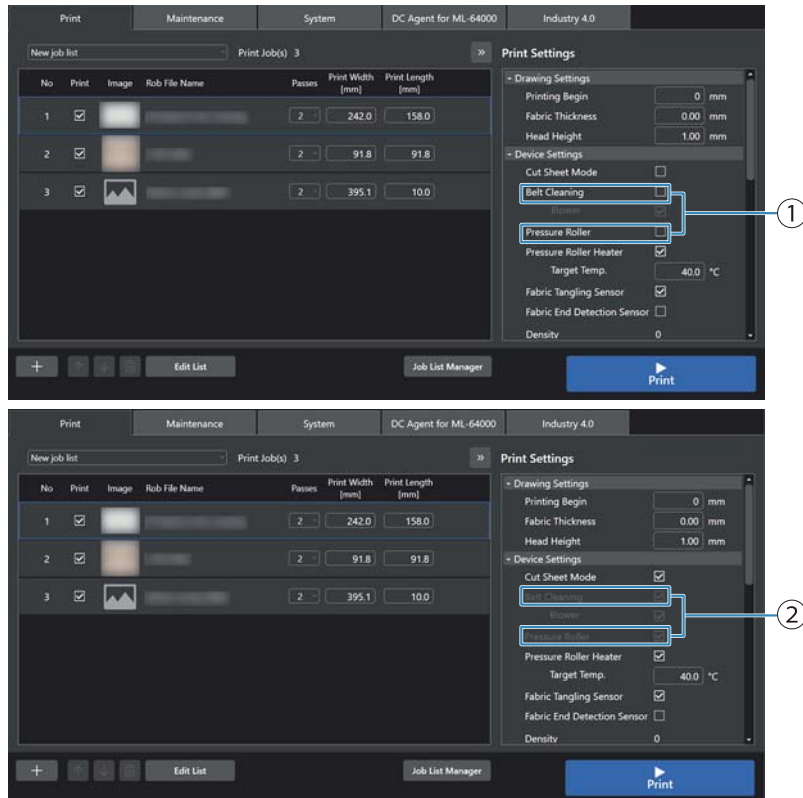

- 2 Clean the belt surface. Use a wipe cloth soaked in ethanol (proper amount) to wipe the belt surface clean while slowly feeding the belt. Wipe off the glue until the belt surface has a luster. Be especially careful to remove the glue from both edges of the belt.



- 3** From the rear side of the machine, attach insulating tape at both edges of the belt, using a clearance of about 6 mm to prevent contact with the belt retention cover. Align the corners of the insulating tape with the edges of the belt.



- 4** Using the belt speed volume, adjust the belt speed to the range shown in the figure. As you slowly rotate the belt in the forward direction, attach the tape through one complete rotation of the belt.



5 After taping one complete rotation, adjust the belt speed volume to Min. (Minimum) and stop the belt.

6 Overlap the tape seams by about 5 to 10 mm.

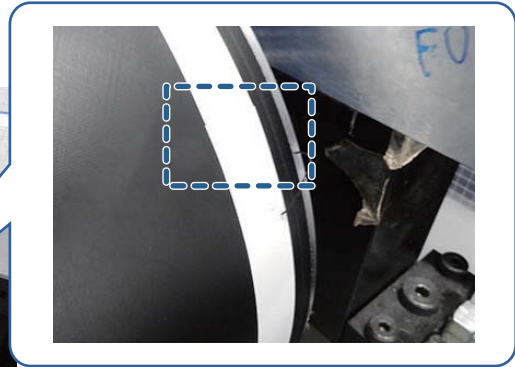

7 Adjust the belt speed volume to a speed that is easy to work with. Aim for a speed that is in the range shown by the arrows in the figure.



- 8** Check to see whether the tape is floating (lifting) and whether there is foreign material on the belt. Press down any areas of tape that are floating up, and remove any foreign material using a wipe cloth or the like.



Note:

If the tape is floating up, friction with the blade could cause the tape to tear during glue application. If the tape tears, the glue cannot be applied uniformly; therefore, the tape must be reapplied.

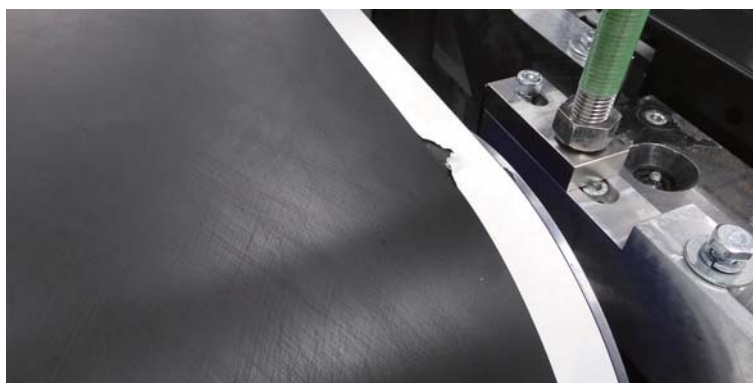

- 9** Clean the blade.
Use a wipe cloth soaked in ethanol to wipe off any dirt on the blade.
If it is extremely dirty, use the glue remover in advance to wipe off the dirt.



WARNING:

When using the glue remover, wear the personal protective equipment for organic solvent use, such as protective gloves, eye protection, and respiratory protection.

- 10** Install the blade.
Use two people to carry the blade to the rear side of the machine.



CAUTION:

Do not place the blade on the floor with the sharp edge facing down, or bump it against other objects. Doing so could damage the sharp edge. A damaged blade will not apply glue uniformly.

- 11** Align the holes on each end of the blade with the blade supports, and slowly and evenly lower the blade on both right and left sides to avoid damaging the belt.



- 12** Rotate the belt a little in the forward direction and stop.
This operation sets the blade at a slight angle against the belt. This completes the blade installation procedure.

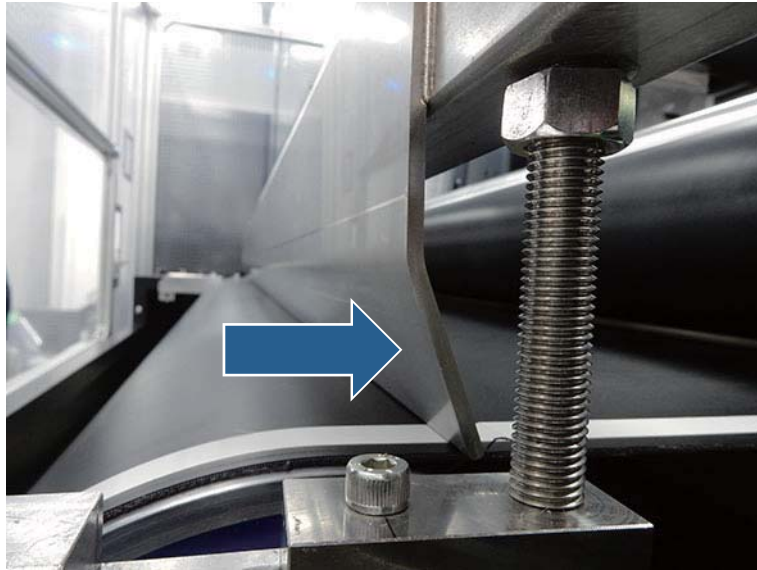

13 Place one glue application block on each end of the belt so that they are aligned with the edge of the blade.

When placing the blocks, do not place them on the seams of the insulating tape applied to both sides of the belt. If the seams of the insulating tape come where you want to place the blocks, feed the belt to where there are no seams.

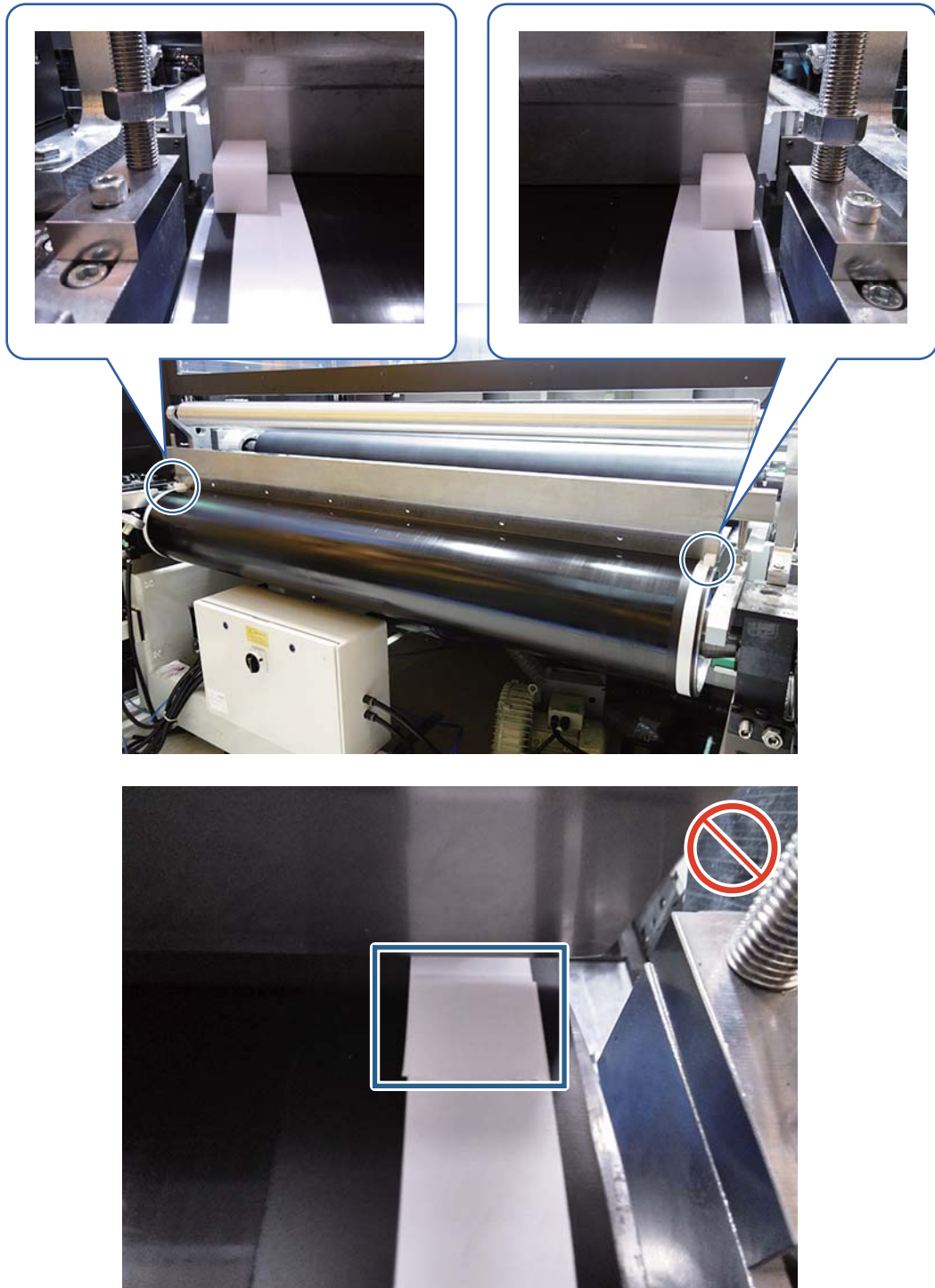

14 Affix the glue application blocks to both ends of the blade using insulating tape so that there are no gaps in the following:

- Between the block and the belt
- Between the block and the blade



CAUTION:

Do not affix the blocks in the states described below. There is a risk that the glue may not be applied evenly, or the glue may leak from the belt edge into the machine, causing a malfunction.

- There is a gap between the block and the belt.

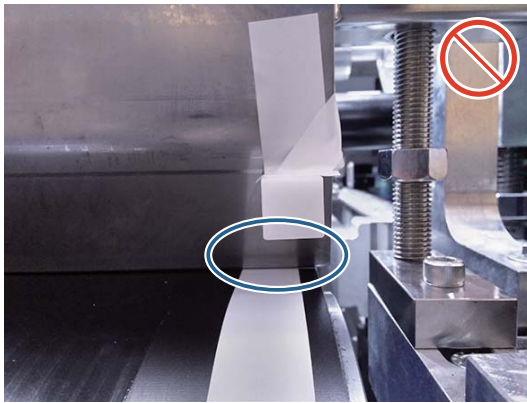

- There is a gap between the block and the blade.

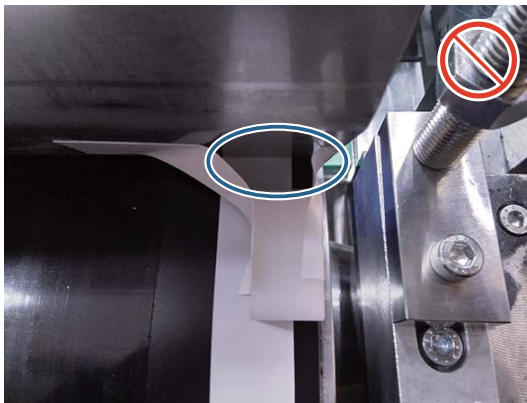

- The block is slanted.

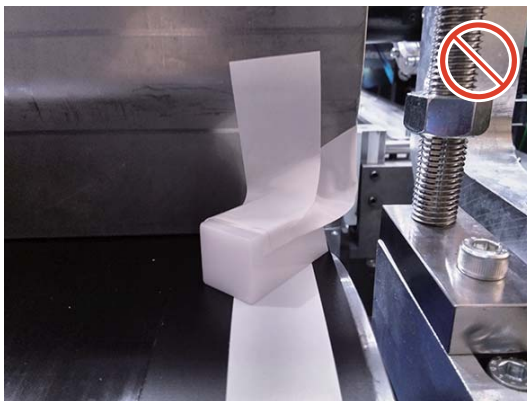

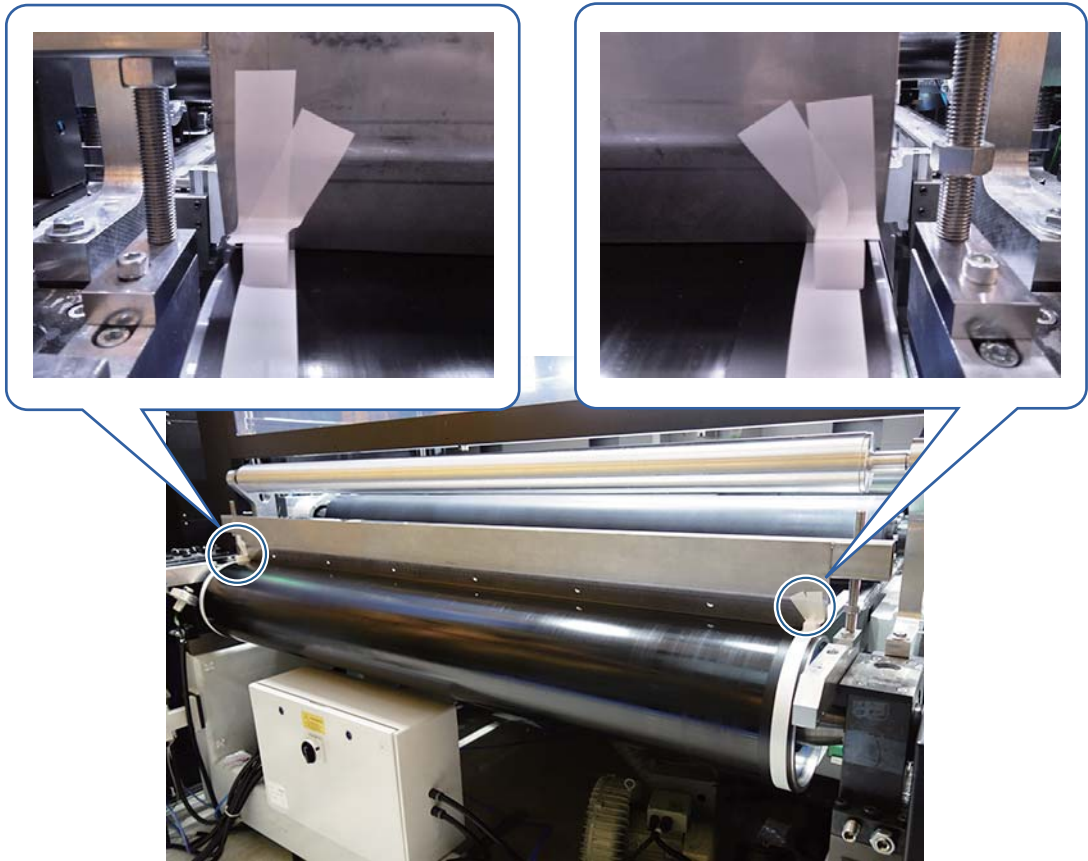

Glue Preparation

This section explains glue preparation to perform when applying glue after performing glue removal, and when applying glue without performing glue removal.

When applying glue after removing glue

When applying a top layer of glue without performing glue removal, see "[When applying glue on top without removing glue](#)" on page 228.

- 1 Prepare the glue for the first layer. Set the bucket for glue on the scale and pour in glue A (2 kg).

**WARNING:**

When using the glue, wear the personal protective equipment for organic solvent use, such as protective gloves, eye protection, and respiratory protection.

Note:

Pour glue into the bucket slowly along the bucket side, to avoid the glue forming bubbles in the bucket.



- 2** Prepare the glue for the second layer.
On the scale, set a bucket for glue that is different from the bucket containing the first layer of glue. Pour in glue A (0.5 kg).



- 3** Pour glue B (0.5 kg) into the bucket containing glue A.



- 4 Using a stirring rod for preparing glue, mix and prepare glue A and glue B contained in the bucket for glue.

Note:

Mix the glue slowly to avoid the glue forming bubbles in the bucket.



- 5 Preparation is complete when the colors of the two glues are blended.

When applying glue on top without removing glue

When applying glue after performing glue removal, see "[When applying glue after removing glue](#)" on page 225.

1 Set the bucket for glue on the scale and pour in glue A (1.4 kg).



WARNING:

When using the glue, wear the personal protective equipment for organic solvent use, such as protective gloves, eye protection, and respiratory protection.

Note:

Pour glue into the bucket slowly along the bucket side, to avoid the glue forming bubbles in the bucket.



2 Pour glue B (0.8 kg) into the bucket containing glue A.



- 3 Using a stirring rod for preparing glue, mix and prepare glue A and glue B contained in the bucket for glue.

Note:

Mix the glue slowly to avoid the glue forming bubbles in the bucket.



- 4 Preparation is complete when the colors of the two glues are blended.

Application of Glue

This section explains glue application to perform when applying glue after performing glue removal, and when applying glue without performing glue removal.

- 1 Adjust the belt speed volume to a speed that is easy to work with.
Aim for a speed that is in the range shown by the arrows in the figure.**



- 2** Apply the first layer of glue. Pour a proper amount of glue to right next to the blade. Pour so that the glue flows from the center to both edges.

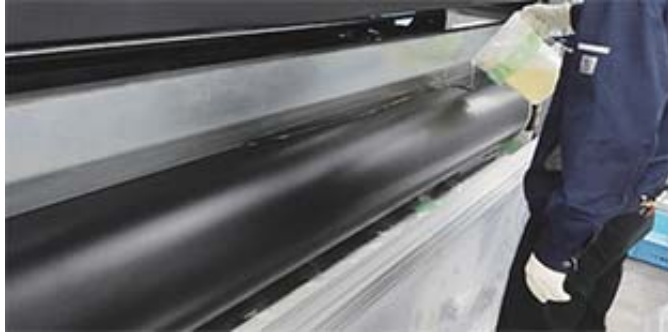

It is not necessary to pour all of the glue at once.

The glue accumulates in front of the blade, then it will be applied slowly to the belt surface through the gap between the blade and belt as the belt rotates. As the glue decreases, pour in a proper amount of more glue.

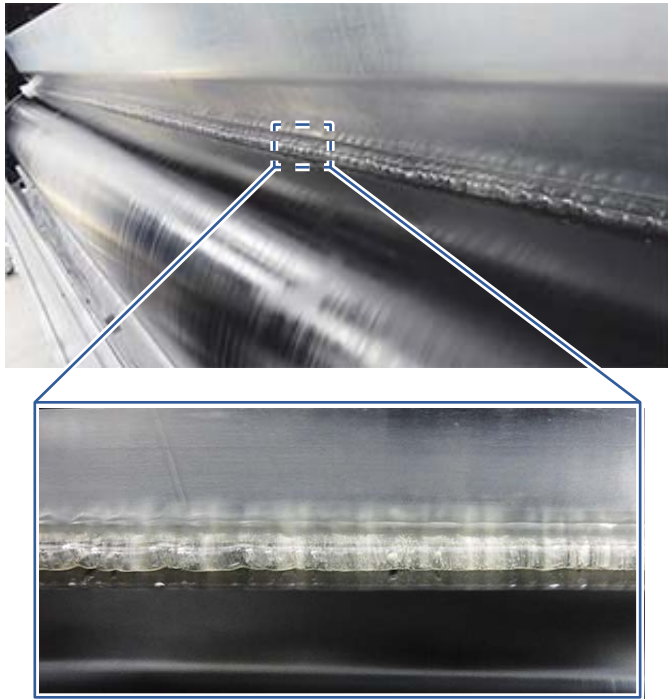

If applying a top layer of glue without performing glue removal, proceed to Procedure 5.

- 3** When the first layer of glue has been completely poured in, prepare the second layer.

- 4** Maintain the belt rotation speed as is, and when the first layer of glue has nearly all been used, pour the second layer.

Note:

Pour the second layer of glue before the first layer has all been used.

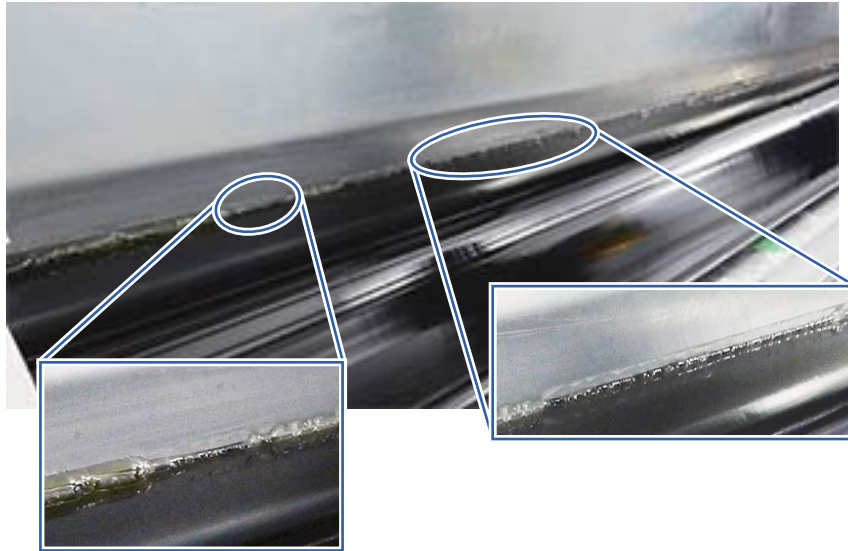

It is not necessary to pour all of the glue at once. Pouring a proper amount a little at a time, apply in the same manner as the first layer.



- 5** After it has been completely poured, prepare the soapy water, and gradually pour the soapy water above the belt in front of locations where the glue has nearly all been used.

The soapy water creates a water repellent membrane on the belt surface so that the glue and blade can be easily separated. Repeat this procedure until the glue is completely used.

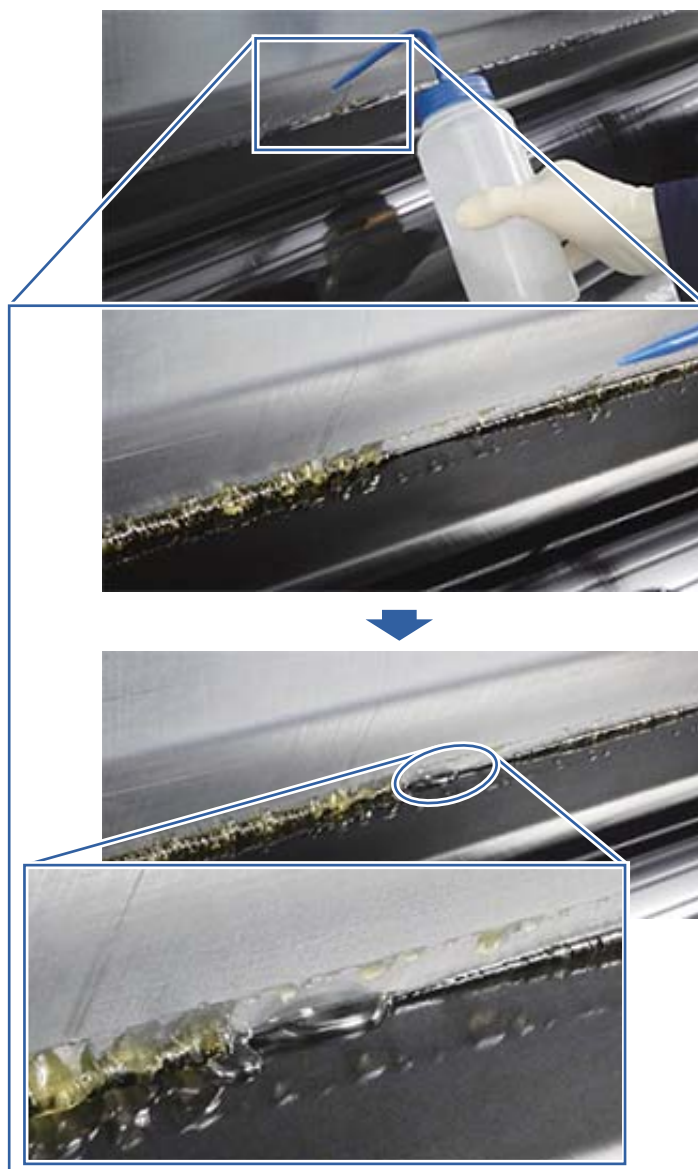

-
- 6** Check that the glue accumulated in front of the blade has been completely used and soapy water is completely applied.

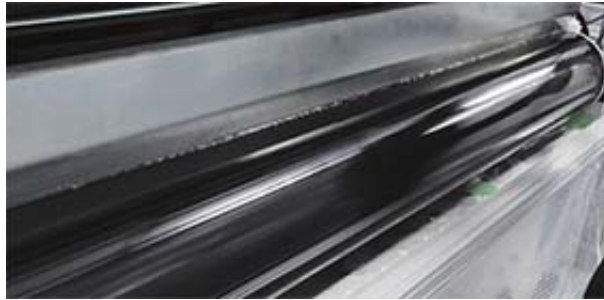

Blade Removal

- 1 Use two people to lift the blade evenly on both right and left sides, and remove it.



- 2 Wipe the blade, glue application blocks, and buckets for glue clean using ethanol. If the dirt cannot be removed, soak a wipe cloth in glue remover to wipe it off.

**WARNING:**

When using the glue remover, wear the personal protective equipment for organic solvent use, such as protective gloves, eye protection, and respiratory protection.

Use wipe cloths or similar to absorb any waste solvents, and then dispose of them in the proper manner for industrial waste.

Drying

- 1 Using the belt speed volume, adjust to the position shown in the figure. Then rotate the belt in the forward direction for two to four hours.



- 2 On the control PC, deselect Enable [Belt speed volume switch] on the [Belt] tab.

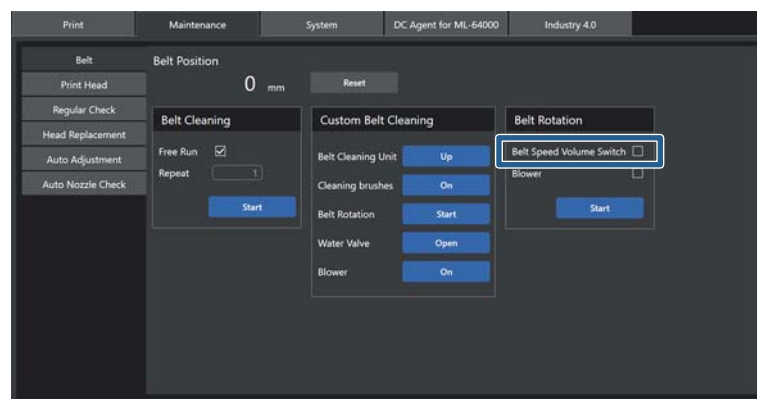

- 3 Stop belt rotation and allow to dry for eight hours or more.

Work after Application

- 1 After leaving it for eight hours or more, peel off the insulating tape.
Worker 1: In front of the machine, peel the edge of the insulating tape, and hold the edge of the bottom tape in the overlapping portion. Peel off the tape from the belt.
Worker 2: Press and hold the Feed button on the front panel to rotate the belt in the forward direction.

Peel the insulating tape on the opposite side in the same way.

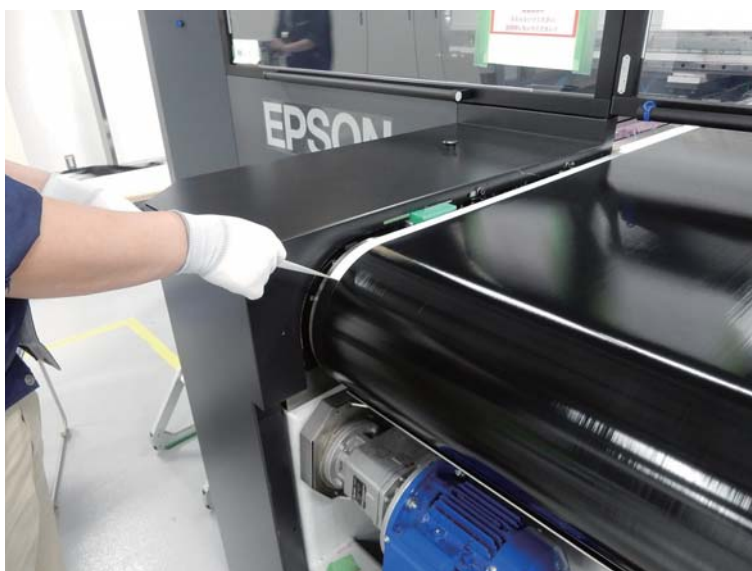
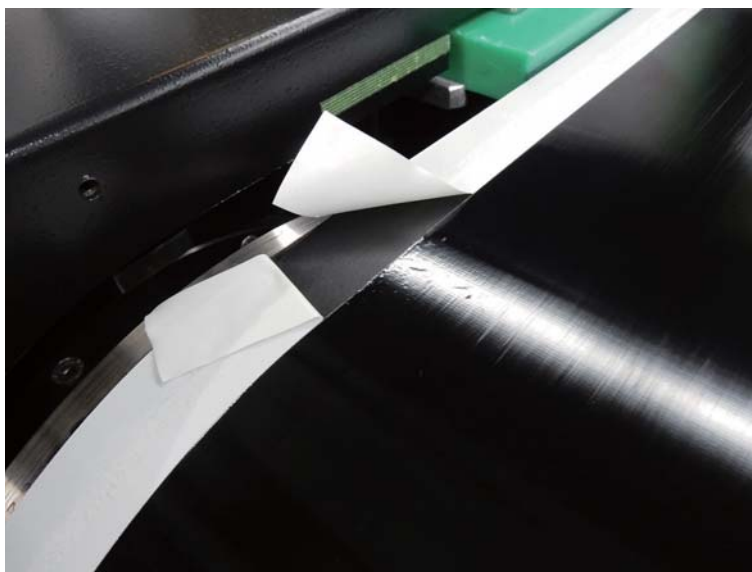

2 Move to the rear side of the machine, and remove the blade supports. Loosen the screws (1 each on right and left) using the hex key (width: 5 mm) to remove them.

3 With two workers, attach the tension roller unit in its original position.



CAUTION:

Be sure to have at least two workers remove and install the unit.
When lifting the unit, make sure you bend your knees sufficiently and lift in a natural position.



4 Tighten and secure the screws on each side of the tension roller unit (2 each) using the spanner (width: 13 mm).

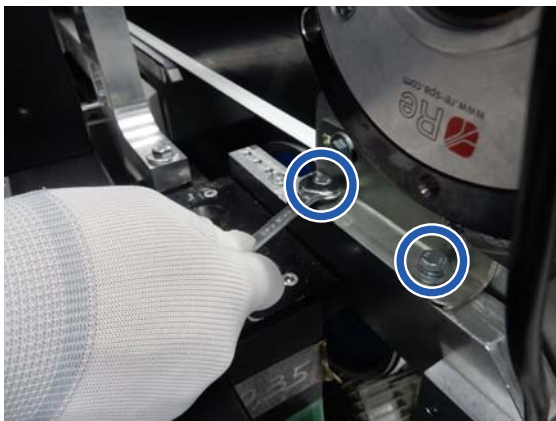

- 5** If you removed roller 1, attach roller 1 in its original position on the tension roller unit and then insert the fixing pins on both sides of the roller. Insert the pin and catch the hook on the pin tip.

**CAUTION:**

Be sure to have at least two workers remove and install the roller.
When lifting the roller, make sure you bend your knees sufficiently and lift in a natural position.

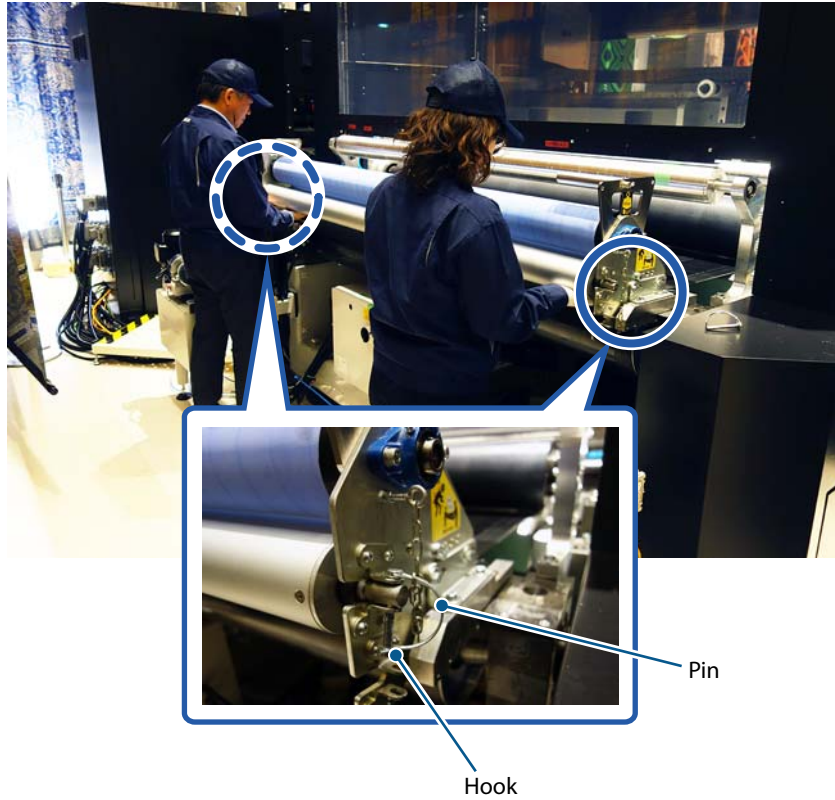

If the position of the roller hole and the hole for inserting the pin are not aligned, move the lever on the left side of the roller to adjust the position.



6 Press the tension roller connector into the electromagnetic brake connector.



- 7** Attach the tension roller covers.
Attach the tension roller cover screws (Home side/Full side, 4 screws each) using the hex key (width: 3 mm).

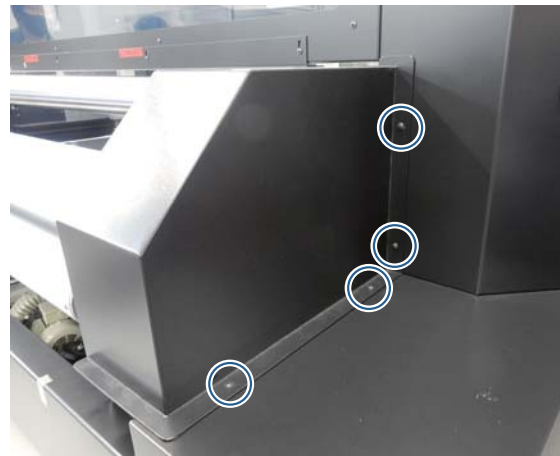

- 8** Use two people to attach the fabric roll.



WARNING:

Since the fabric roll is heavy, be sure to have at least two workers remove and install it. When lifting the fabric roll, make sure you bend your knees sufficiently and lift in a natural position.

This completes the work.

Shaking the Ink Cartridges

Frequency	When the machine was not used for a long period of time with the ink cartridges still installed <ul style="list-style-type: none">• Pigment ink (red): Once every three weeks• Pigment ink (other than red)/Dispersion ink: Once a month• Reactive ink, acidic ink: Shaking not required
Personal protective equipment	Protective gloves and clothing

When the machine has not been used for a long period of time with the ink cartridges still installed, remove the ink cartridges and shake them.

This operation can be done with the machine power turned on or off.

The shaking method to be followed after the installation differs from that followed when opening the ink cartridge. Follow the steps below for shaking.

1 Pull the ink rack front bar towards you and down.



- 2** Grabbing the blue levers on both sides of the connector, pull the connector out toward you and place it on the holder.



- 3** Remove the ink cartridge from the ink rack, and place it on a flat surface with the ink supply port facing the side.

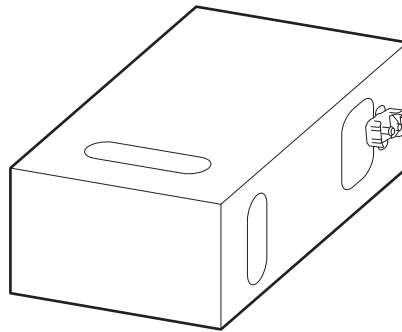

- 4** Slide the ink cartridge back and forth longitudinally within a range of approximately 10 cm. Do three times for the front and back. Move the ink cartridge at a rate of one back-and-forth cycle per second.

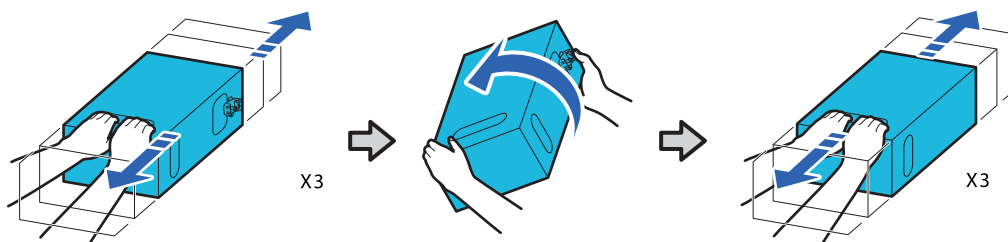

- 5** Place the shaken ink cartridge such that the ink supply port faces the connector
- 6** Insert the connector of the ink rack into the ink supply port of the ink cartridge. Push the needle of the connector into the ink supply port of the ink cartridge. Insert it carefully and securely as shown in the following image.

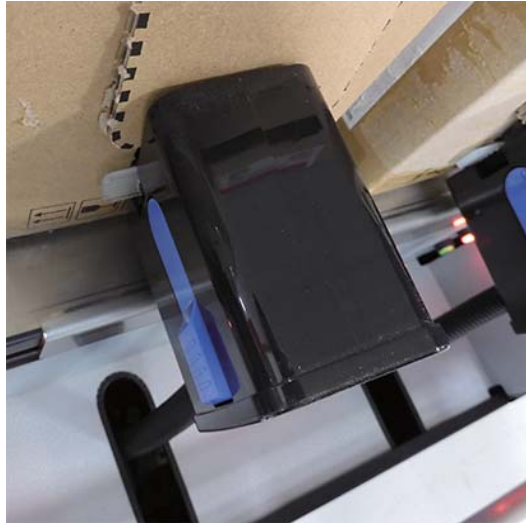

- 7** Raise the ink rack front bar up.

This completes ink replacement.

Repeat the same procedure to shake other ink cartridges.

Print Head Replacement

Cleaning the Head Nozzle Surface (Clean Stick)

Frequency	If nozzles are still clogged even after performing "Head Cleaning" on page 55 several times
Personal protective equipment	Protective gloves and clothing, eye protection
Required items	Clean stick, maintenance liquid, plastic container, tray

Safety Precautions

- When cleaning, remove the fabric from the printer before starting work.
- Never touch any parts, belts, or circuit boards other than those that need to be cleaned. Doing so may cause the printer to malfunction or a decline in print quality to occur.
- If the clean stick/NOZZLE RECOVERY JIG become dirty, replace them with new ones. Re-using dirty instruments can actually make the printer dirtier.
- Do not touch the tip of the clean stick or the brush of the NOZZLE RECOVERY JIG with your hands. Oils from your fingers may adhere to the print head causing damage.
- Touch a metal object before starting operations to disperse any static electricity from your body.

1 Print a nozzle check pattern to identify the head and chip affected by nozzle clogging. For more information about how to print a nozzle check pattern, refer to ["Nozzle Check" on page 51.](#)

The text printed under each pattern indicates the location of the nozzle.

Upper row:

Indicates the head number.

Print heads are numbered from the right side toward the rear when viewed from the front of the printer.

Lower row:

Indicates the chip number.

Chips are numbered from the right side toward the rear when viewed from the front of the printer.

- Cleaning is performed on a chip set.
- A print head consists of four chips.
- A chip consists of two nozzle rows. For example, if nozzle clogging has occurred in the "Head 32 Chip 128" nozzle for the color cyan, cleaning will also include the "Head 32 Chip 128" nozzle for the color black.

<Nozzle check pattern>

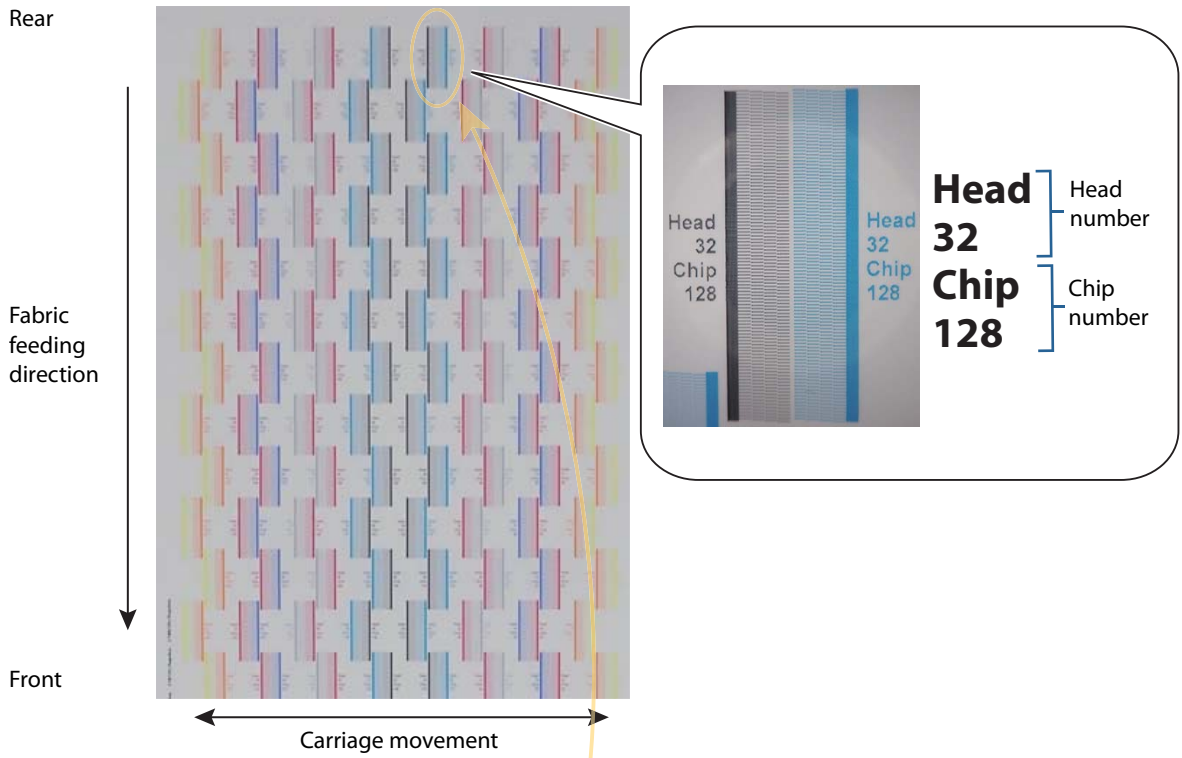

<Head arrangement>

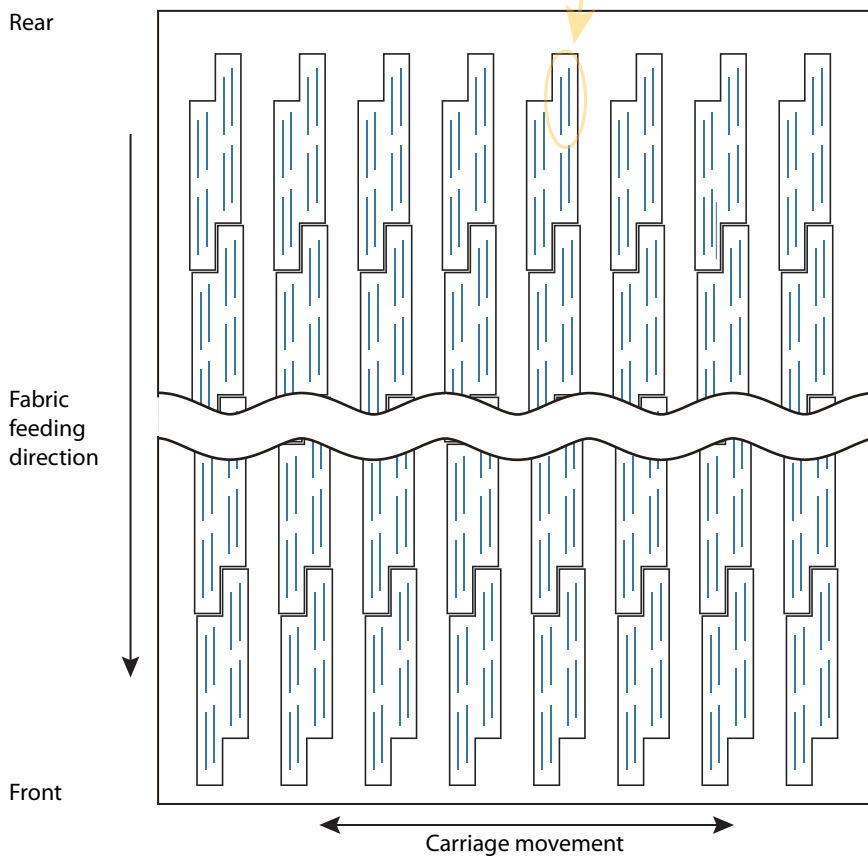

- 2 On the screen of the control PC, press Head Maintenance - [Move to Home] on the [Regular Check] tab in the [Maintenance] menu.

The print head separates from the cap. The side doors unlock.

- 3 Move the display of the control PC to the outer side.



- 4 Open the front cover (Home).

- 5 Open the maintenance cover beside the belt on the Home side, and align it with the maintenance cover below the front cover.

- 6 Grab the handle of the maintenance cover below the front cover and slowly open the maintenance cover.

- 7 While pulling the knob of the stopper on the cleaning station toward you with your left hand, use your right hand to slightly pull out the cleaning station.

- 8 Grab the handle on the cleaning station and slowly pull it out toward you.

- 9 Place the plastic container on the tray and pour in about 10 ml of cleaning liquid.

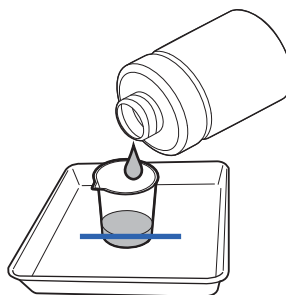

- 10 Taking the items below with you, move into the machine from the side door (Home).
Plastic container containing cleaning liquid, clean stick

11 Soak a cleaning stick in the cleaning liquid.

When doing this, do not allow cleaning liquid to drip from the clean stick.

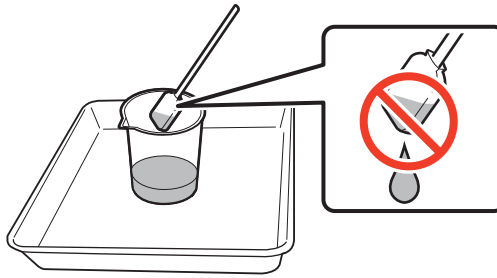

Do not re-use the cleaning liquid the next time you perform cleaning. Re-using dirty cleaning liquid can actually make the printer dirtier.

- Close the lid tightly and store the cleaning liquid at room temperature and away from locations subject to high temperature, high humidity, and direct sunlight.
- Used cleaning liquid and clean sticks are industrial waste. Dispose of these in the same way as waste ink.

12 Gently press the clean stick to the nozzle surface of the affected head at no more than a 30 degree angle. Apply the clean stick so that the surface of the clean stick is level with the nozzle surface.



Do not apply the clean stick perpendicular (vertical) to the nozzle surface. Wiping with the tip of the clean stick will apply an excessive force to the nozzle surface, which may damage the nozzle surface and lead to printing defects.



- 13** While keeping the clean stick at an angle of 30 degrees or less, wipe off the fluff by sliding it in the direction of the acute angle while pressing with just enough force so that the stick does not bend.

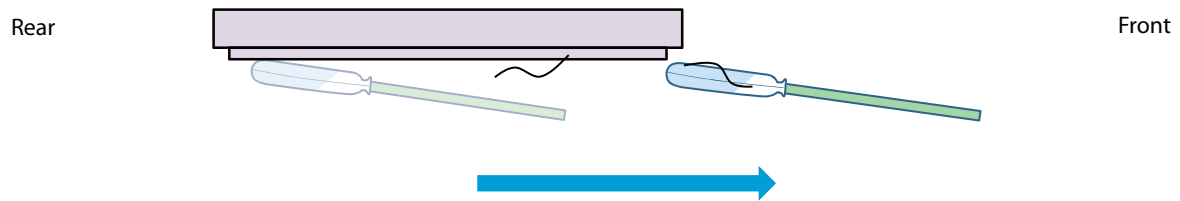

Keep the following points in mind. Scratching the nozzle surface may result in poor printing.

- Do not use at an angle of more than 30 degrees
- Do not push with strong force (if the clean stick bends, too much force is being applied)
- Do not wipe if the stick is dry
- Do not wipe too much (up to 5 times in a row for the same nozzle surface)

- 14** Exit the machine from the side door (Home).

- 15** Return the cleaning station.

Grabbing the cleaning station's handle and being careful not to pinch any cables, slowly push it back into its original position until you hear the stopper click into place.

- 16** Slowly close the maintenance cover below the front cover.

- 17** Return the maintenance cover beside the belt on the Home side to its original position.

- 18** Check to see if the display of the control PC has been moved to the outer side.
If it has not been moved, move the display of the control PC to the outer side.

- 19** Close the front cover (Home).

- 20** Return the control PC to its original position.

- 21** Make sure nobody is inside the machine, then close the side door and press the Confirm button.

- 22** On the screen of the control PC, press [Capping].
The print heads are capped. The side doors lock.

- 23** Execute cleaning for the print head.
For more information, refer to ["Head Cleaning" on page 55](#).

24 Print a nozzle check pattern to check for clogged nozzles.

If no clogged nozzles are detected, the work is complete.

If the nozzles are still clogged, start again from Procedure 2.

If the problem continues to occur even after trying to clear the nozzles a few times, go to "[Cleaning the Head Nozzle Surface \(NOZZLE RECOVERY JIG\)](#)" on page 252.

If you want to print while the nozzles are still clogged even after performing head cleaning several times, set the number of print heads to be used to 32 heads before printing. Refer to "[Printing While the Nozzles Are Still Clogged](#)" on page 310.

Cleaning the Head Nozzle Surface (NOZZLE RECOVERY JIG)

Frequency	If nozzles are still clogged even after performing " Cleaning the Head Nozzle Surface (Clean Stick) " on page 245 several times
Personal protective equipment	Protective gloves and clothing, eye protection
Required items	NOZZLE RECOVERY JIG, maintenance liquid, plastic container, tray

Safety Precautions

- When cleaning, remove the fabric from the printer before starting work.
- Never touch any parts, belts, or circuit boards other than those that need to be cleaned. Doing so may cause the printer to malfunction or a decline in print quality to occur.
- If the clean stick/NOZZLE RECOVERY JIG become dirty, replace them with new ones. Re-using dirty instruments can actually make the printer dirtier.
- Do not touch the tip of the clean stick or the brush of the NOZZLE RECOVERY JIG with your hands. Oils from your fingers may adhere to the print head causing damage.
- Touch a metal object before starting operations to disperse any static electricity from your body.

1 Print a nozzle check pattern to identify the head and chip affected by nozzle clogging.

For more information about how to print a nozzle check pattern, refer to "[Nozzle Check](#)" on page 51.

2 On the screen of the control PC, press Head Maintenance - [Move to Home] on the [Regular Check] tab in the [Maintenance] menu.

The print head separates from the cap. The side doors unlock.

3 Move the display of the control PC to the outer side.



- 4 Open the front cover (Home).
- 5 Open the maintenance cover beside the belt on the Home side, and align it with the maintenance cover below the front cover.
- 6 Grab the handle of the maintenance cover below the front cover and slowly open the maintenance cover.
- 7 While pulling the knob of the stopper on the cleaning station toward you with your left hand, use your right hand to slightly pull out the cleaning station.
- 8 Grab the handle on the cleaning station and slowly pull it out toward you.
- 9 Place the plastic container on the tray and pour in about 10 ml of cleaning liquid.

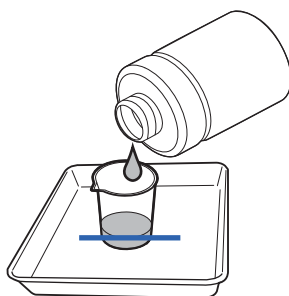

- 10 Taking the items below with you, move into the machine from the side door (Home).
Plastic container containing cleaning liquid, NOZZLE RECOVERY JIG
- 11 Soak the entire brush in the cleaning liquid.

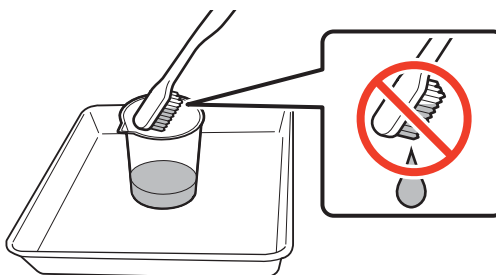

Do not re-use the cleaning liquid the next time you perform cleaning. Re-using dirty cleaning liquid can actually make the printer dirtier.

- Close the lid tightly and store the cleaning liquid at room temperature and away from locations subject to high temperature, high humidity, and direct sunlight.
- Used cleaning liquid and brushes are classed as industrial waste. Dispose of these in the same way as waste ink.

- 12 Lightly press the brush against the nozzle surface of the corresponding head so that the bristles are not pressing too hard, and scrub in small increments. Scrub

approximately half of the nozzle surface at a time. Scrub the entire nozzle surface with the brush two or three times.

Rear

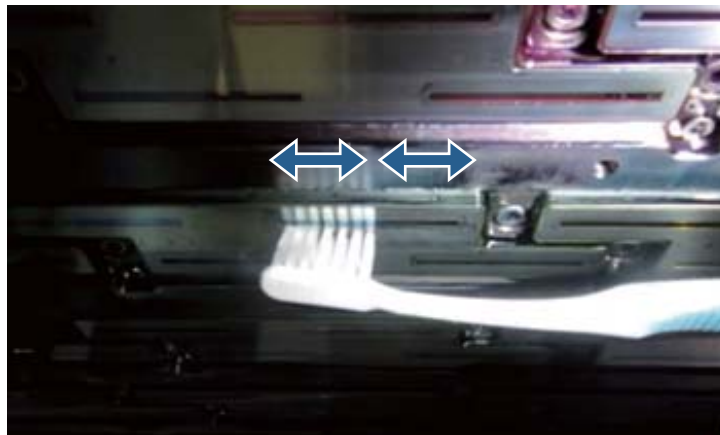

Front



If the bristles of the brush are pressed too hard against the surface, they can create too much of a load and scratch the nozzle surface, resulting in poor printing.



13 Use a clean stick soaked in cleaning liquid to remove dust and fluff scraped out by the brush.

- Apply the clean stick so that its surface is horizontal to the nozzle surface.
- Keep the clean stick at an angle of 30 degrees or less, and press and slide the clean stick at a sharp angle while preventing the stick from bending to wipe away any fluffy dust.

Rear

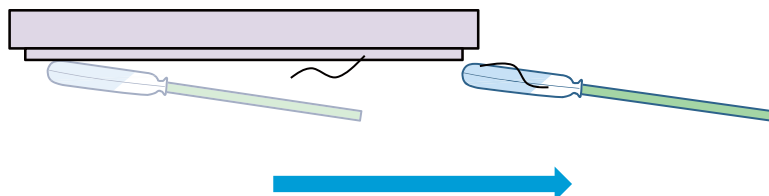

Front



Keep the following points in mind. Scratching the nozzle surface may result in poor printing.

- Do not use at an angle of more than 30 degrees
- Do not push with strong force (if the clean stick bends, too much force is being applied)
- Do not wipe if the stick is dry
- Do not wipe too much (up to 5 times in a row for the same nozzle surface)

- 14** Exit the machine from the side door (Home).
- 15** Return the cleaning station.
Grabbing the cleaning station's handle and being careful not to pinch any cables, slowly push it back into its original position until you hear the stopper click into place.
- 16** Slowly close the maintenance cover below the front cover.
- 17** Return the maintenance cover beside the belt on the Home side to its original position.
- 18** Check to see if the display of the control PC has been moved to the outer side.
If it has not been moved, move the display of the control PC to the outer side.
- 19** Close the front cover (Home).
- 20** Return the control PC to its original position.
- 21** Make sure nobody is inside the machine, then close the side door and press the Confirm button.
- 22** On the screen of the control PC, press [Capping].
The print heads are capped. The side doors lock.
- 23** Execute cleaning for the print head.
For more information, refer to ["Head Cleaning" on page 55](#).
- 24** Print a nozzle check pattern to check for clogged nozzles.
If no clogged nozzles are detected, the work is complete.
If the nozzles are still clogged, start again from Procedure 2.
If the problem continues to occur even after trying to clear the nozzles a few times, go to ["Print Head Replacement" on page 256](#).
If you want to print while the nozzles are still clogged even after performing head cleaning several times, set the number of print heads to be used to 32 heads before printing. Refer to ["Printing While the Nozzles Are Still Clogged" on page 310](#).

Print Head Replacement

Print heads are precision components. When handling them, follow the procedures and precautions in this manual.

Frequency	If nozzles are still clogged even after performing " Cleaning the Head Nozzle Surface (NOZZLE RECOVERY JIG) " on page 252 several times
Personal protective equipment	Protective gloves and clothing, eye protection

Safety Precautions

- Do not open the outer carton or the protective case before doing replacement work.
There is a risk of lint or dust getting on the nozzle surfaces and ink supply ports.
- Store them in the following environment, away from direct sunlight.
-20°C to 60°C (no condensation)
- Do not store in a damp location.
- Store correctly in upright orientation.
- Do not stack more than 3 boxes.

Notes on Opening

- If you move the print head from a cold place to a warm place, leave it at room temperature for at least 30 minutes to prevent condensation from forming before opening the outer box.
- Confirm the box is upright before opening it.
- Use the outer carton, plastic bag, and protective case to pack the used Print Head to send it to your dealer or Epson Support. Open them carefully without tearing anything.
- Do not open the protective case until you are ready to replace the print head.
There is a risk of lint or dust getting on the nozzle surfaces and ink supply ports.

Opening Method

Follow the steps below to open it.

- 1 Open the protective case of the print head.



2 Put your fingers in the concave areas, located on both sides of the Print Head, and take out the print head.

To take it out, hold the print head from the top or its sides. Do not hold the bottom of the print head.



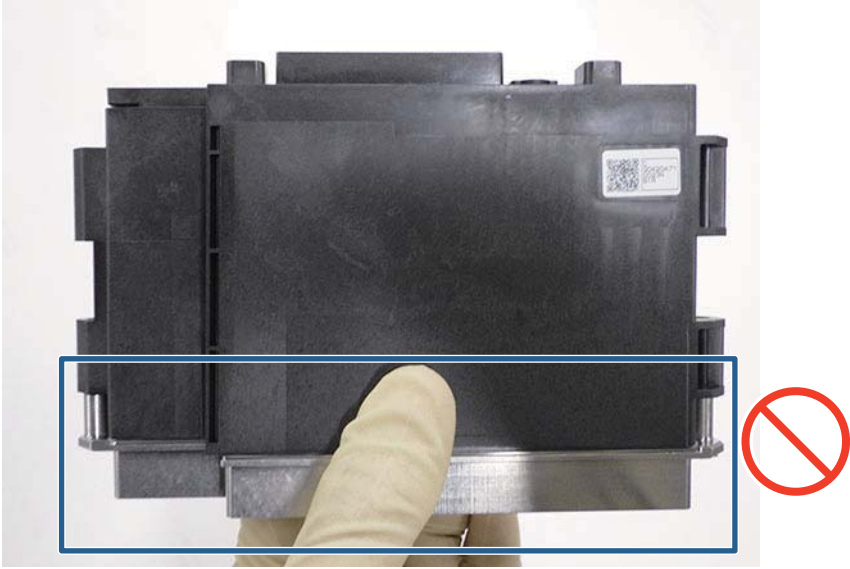

Preparing to Replace the Head

To replace the print head, you will need to turn the power to the printer off.

Prepare the print head so that you can replace the print head when the power to the printer is turned off.

Note:

When replacing the print head, you will not be able to perform any printing jobs until all tasks shown in the [Head Replacement] tab from the [Maintenance] menu are complete.

- 1 On the screen of the control PC, press [Prepare to Replace Head] on the [Head Replacement] tab in the [Maintenance] menu.
- 2 This moves the print head into the replacement position.
If the print head you want to replace is in rows 1 to 4, press [Head Maintenance] - [Move to Home].
If the print head you want to replace is in rows 5 to 8, press [Move to Full].
The print head separates from the cap. The side doors unlock.

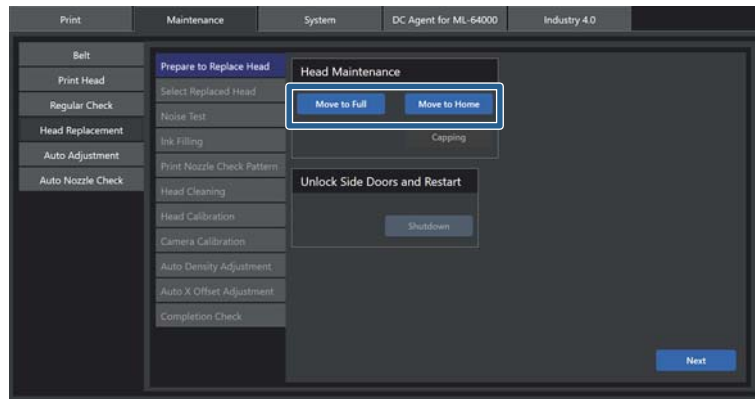

<Head arrangement>

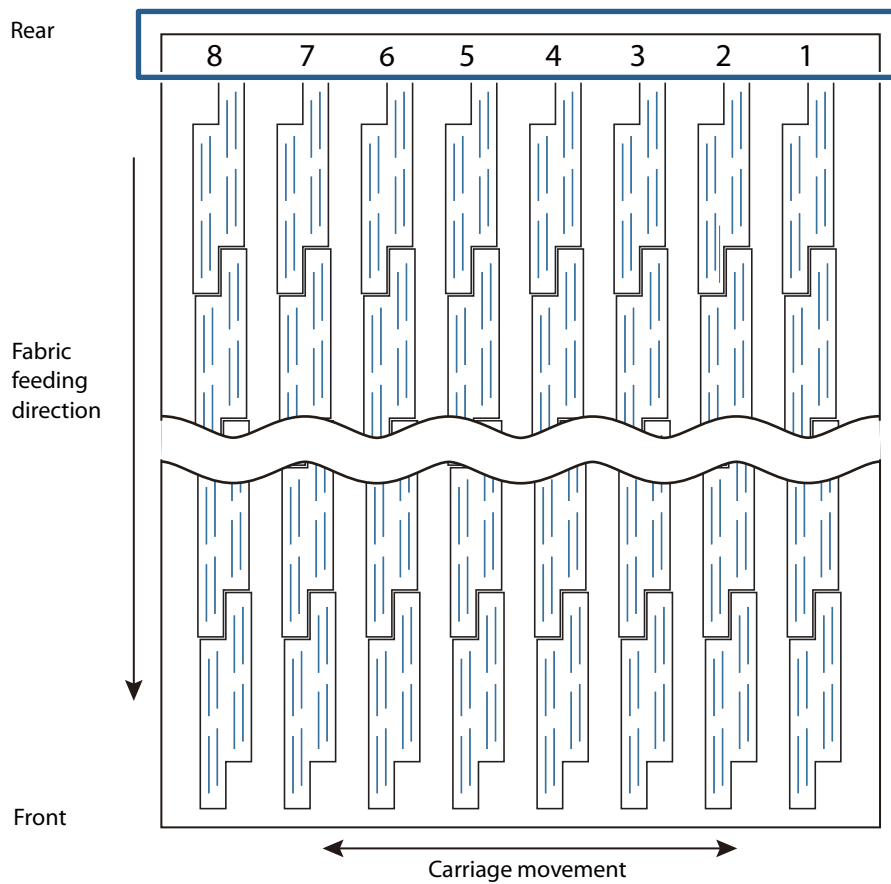

3 Open the side door (Home or Full).

4 Press [Shutdown].
The application on the control PC shuts down.

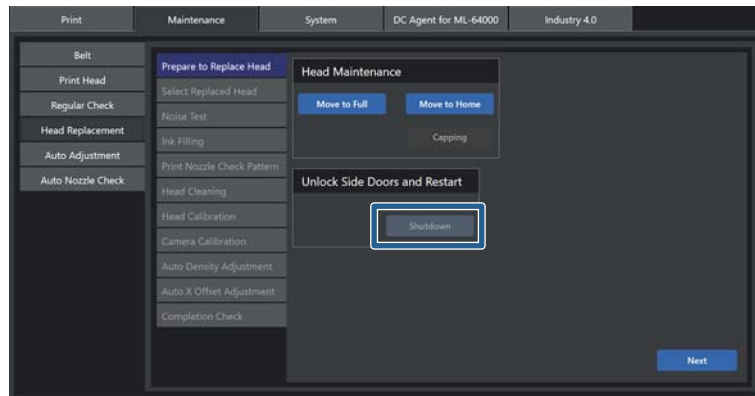

5 Confirm that all signal lamps have turned off, and then turn the main power switch on the main electric box to 0 (Off).



CAUTION:

If the signal lamps have not turned off within 5 minutes after Windows shuts down, press and hold the control PC's power button in the electric box.
If the main power is turned off before the signal lamps turn off, control PC data may get lost or damaged.

Print Head Replacement

Replace the print head with a new print head.

Required items	Torque wrench, bits (width: 3.0 mm, 2.5 mm, 2.0 mm), hex key (width: 3 mm, 2.5 mm, 2.0 mm), lighting
----------------	--

- 1 When opening the front cover (Home), move the display of the control PC to the outer side.



- 2 Open the front cover (Home or Full).
- 3 Remove the screws on the front side of the print head cover (4 screws) using the hex key (width: 3 mm).

**CAUTION:**

Do not apply excessive force to the print head cover. Doing so may damage the print head cover.



- 4** Loosen the screws on the left and right sides of the print head cover (1 screw each) by turning the hex key (width: 3 mm) three times.



- 5** Pull the print head cover toward you to remove it.
When replacing the print head from the Full side, skip to Procedure 10.



- 6** Open the maintenance cover beside the belt on the Home side, and align it with the maintenance cover below the front cover.
- 7** Grab the handle of the maintenance cover below the front cover and slowly open the maintenance cover.
- 8** While pulling the knob of the stopper on the cleaning station toward you with your left hand, use your right hand to slightly pull out the cleaning station.
- 9** Grab the handle on the cleaning station and slowly pull it out toward you.
- 10** Move into the machine from the side door (Home or Full).
- 11** Fully loosen the screws (2 screws) on the connector for the print head's electrical connection using the hex key (width: 2.5 mm) to remove the connector.

Connector for the electrical connection

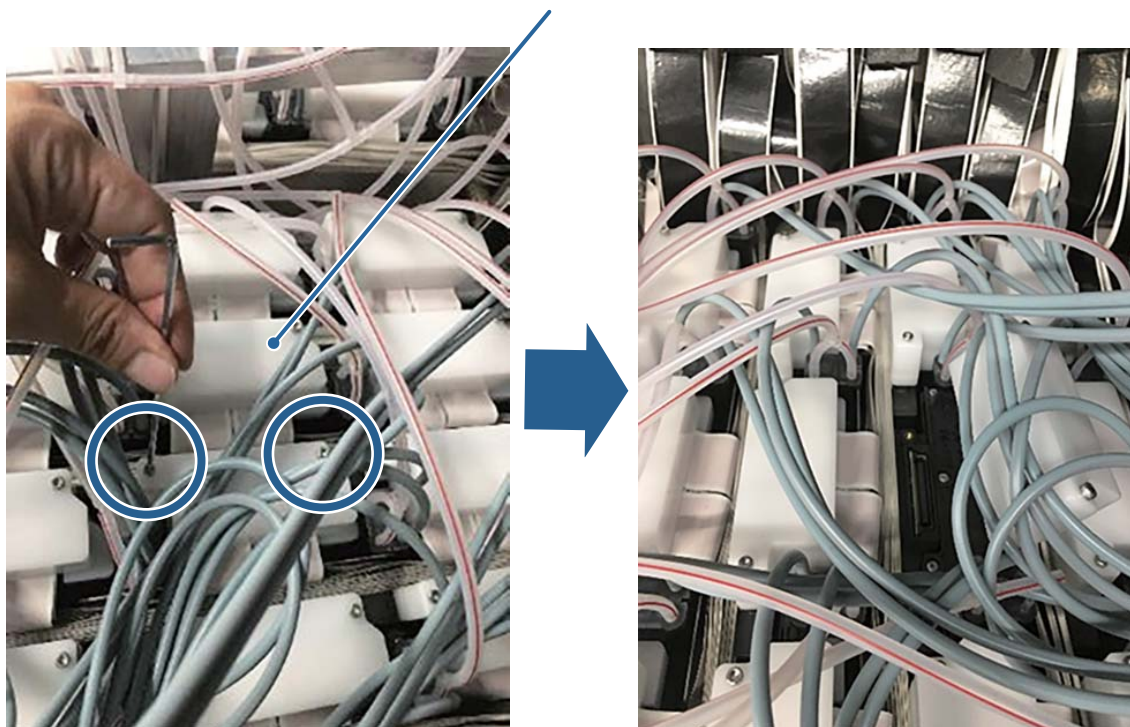

- 12** While shining a light on the underside of the print head, fully loosen the screws (2 screws) on the print head being replaced using the hex key (width: 3 mm).



- 13** Hold the print head being replaced from the top, and pull it out directly upwards.

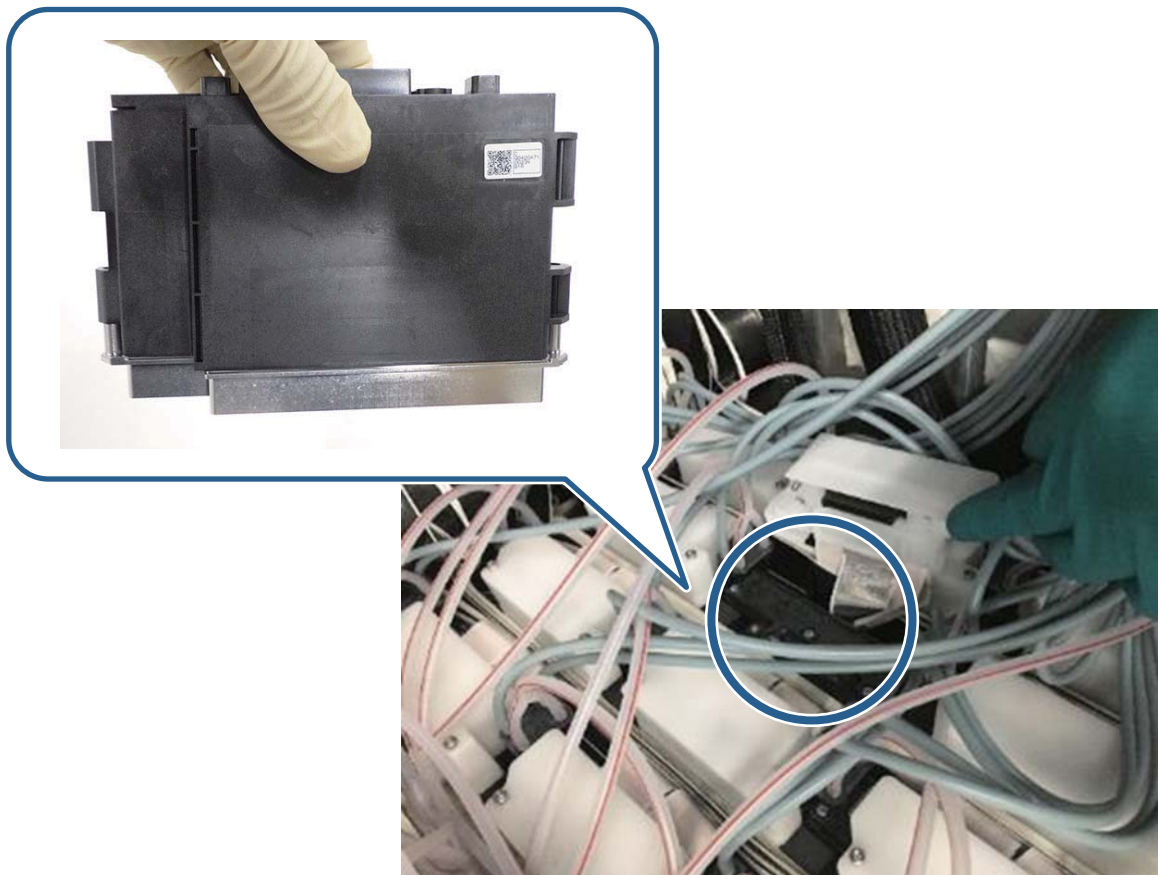

- 14** Fully loosen the screws (2 screws) on the tube connector for the print head being replaced using the hex key (width: 2.0 mm).

Tube connector

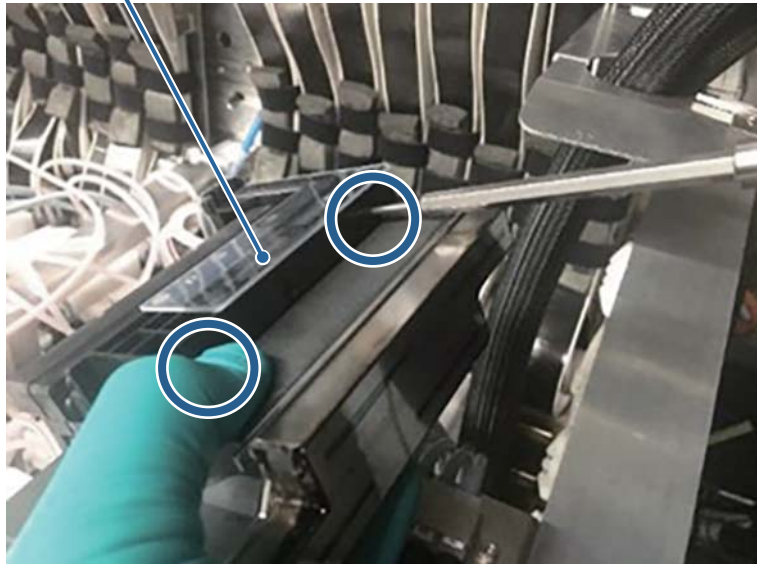

- 15** Remove the tube connector from the print head.

**CAUTION:**

Ink may have stuck to the connection between the tube connector and the print head.
Do not tilt or touch the connections.

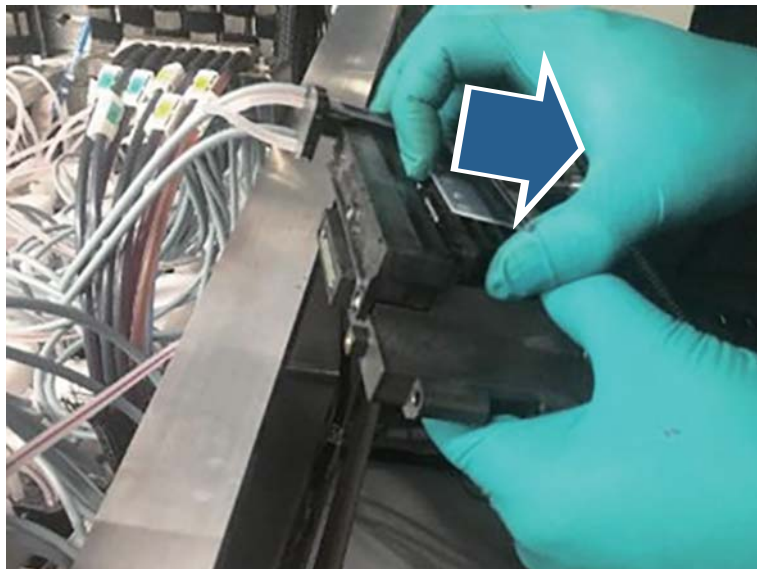

16 Insert the tube connector removed in step 15 into the new print head.

Make sure that the tube connector is inserted straight into the print head connection.



CAUTION:

Ink may have stuck to the connection between the tube connector and the print head. Do not tilt or touch the connections.

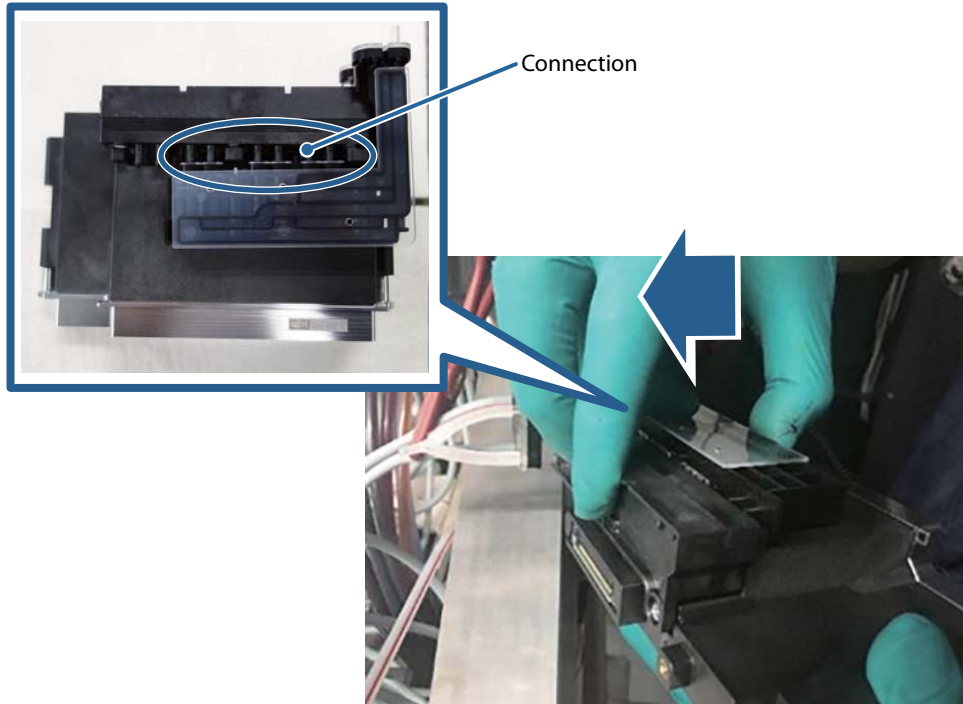

17 Tighten the screws (2 screws) on the tube connector using the bit (width: 2.0 mm).

Tighten to a torque of 18 cN m.

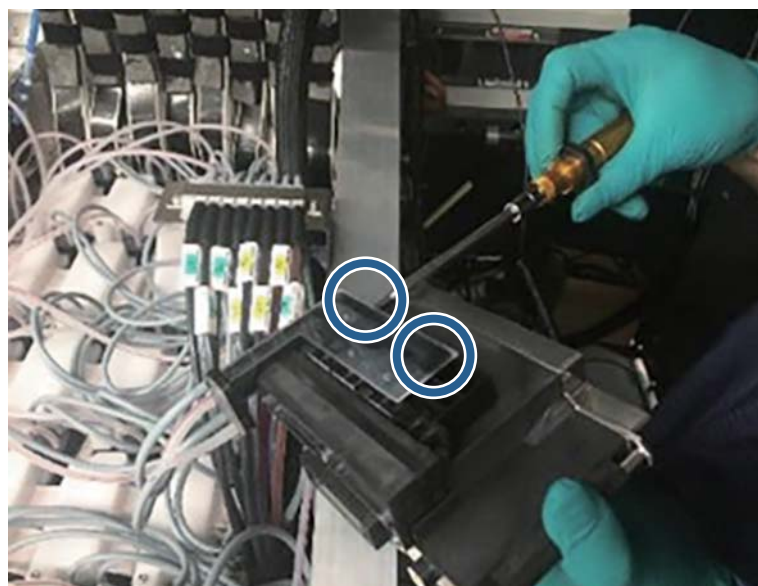

- 18 Set the new print head, and press it straight down until you hear a click. Press the location in the figure.

**CAUTION:**

Do not apply excessive force when inserting.
Doing so may damage the print head and connector.

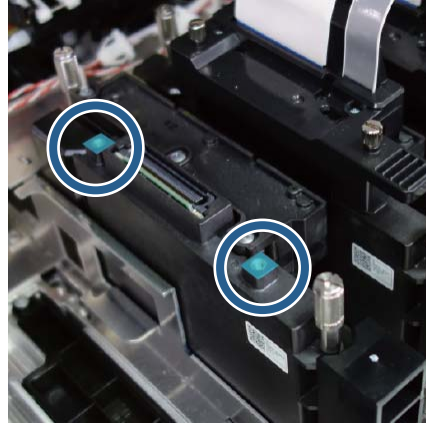

19 While shining a light on the underside of the print head, tighten the screws at two points on the replacement print head using the bit (width: 3 mm).

Tighten to a torque of 150 cN m.



20 Attach the connector for the electrical connection to the new print head vertically.



CAUTION:

Do not apply excessive force when inserting.
Doing so may damage the print head and connector.

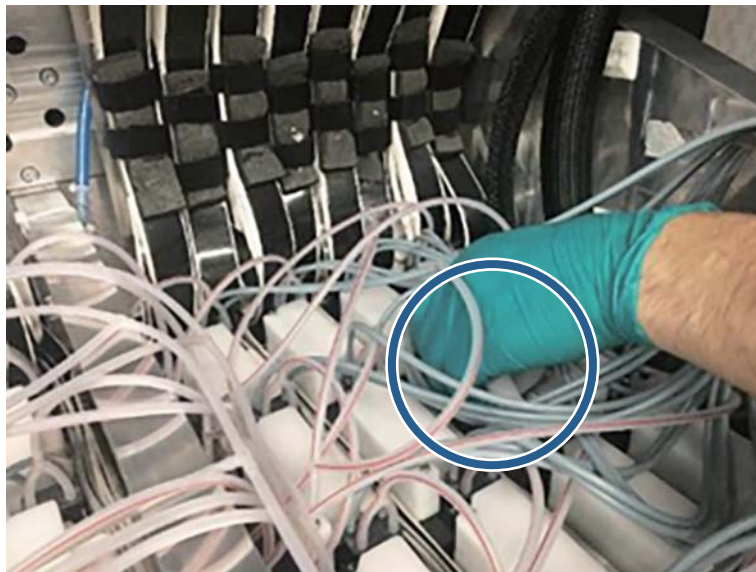

- 21** Tighten the screws (2 screws) on the connector for the electrical connection using the bit (width: 2.5 mm) while avoiding pinching the tube.

Tighten to a torque of 36 cN m.

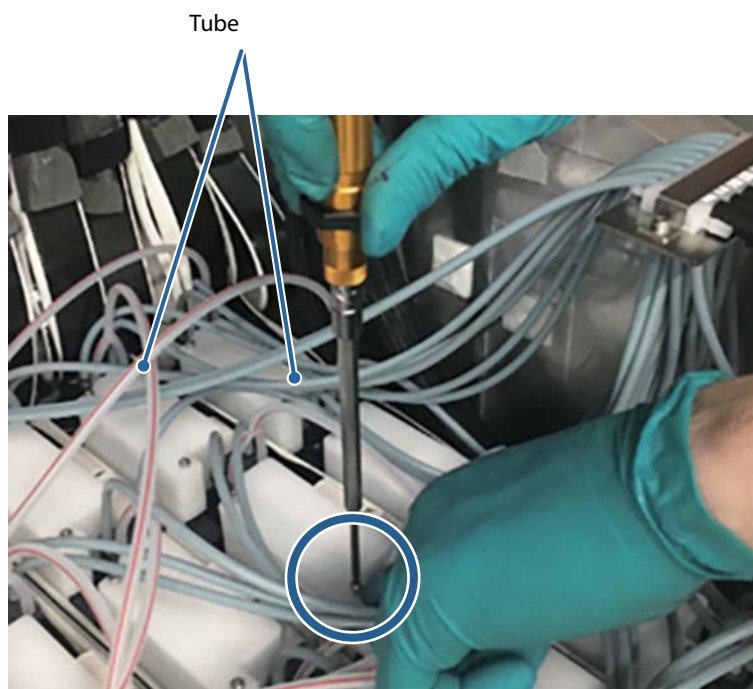

- 22** Exit the machine from the side door (Home or Full).

When replacing the print head from the Full side, skip to Procedure 26.

- 23** Return the cleaning station.

Grabbing the cleaning station's handle and being careful not to pinch any cables, slowly push it back into its original position until you hear the stopper click into place.

- 24** Slowly close the maintenance cover below the front cover.

- 25** Return the maintenance cover beside the belt on the Home side to its original position.

- 26** Make sure nobody is inside the machine, then close the side door.

27 Place the print head cover over the metal plate of the print head on the left, right, and center of the print head.

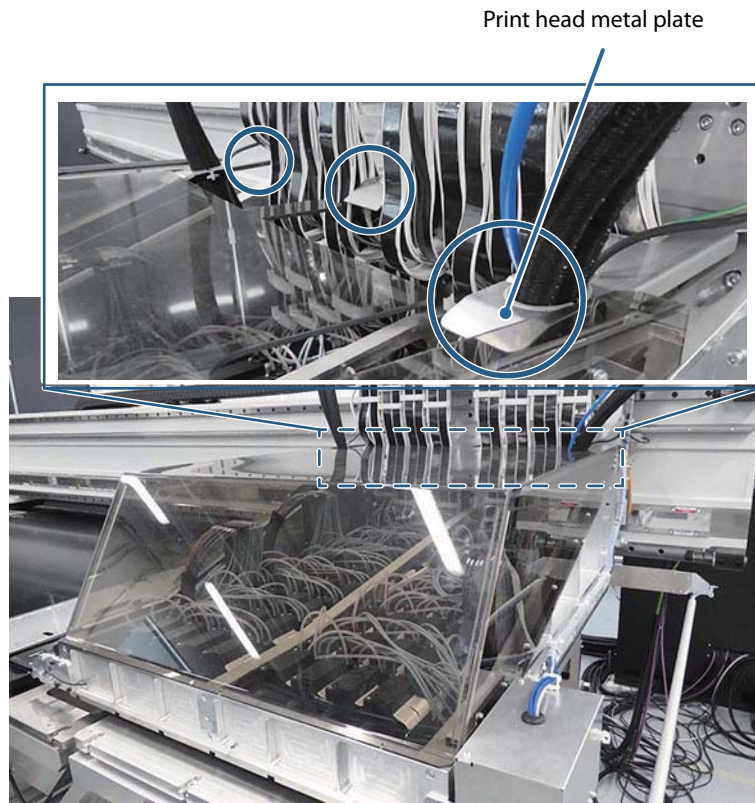

28 Push in the print head cover while making sure that the screws fit into the grooves on the left and right of the print head cover.

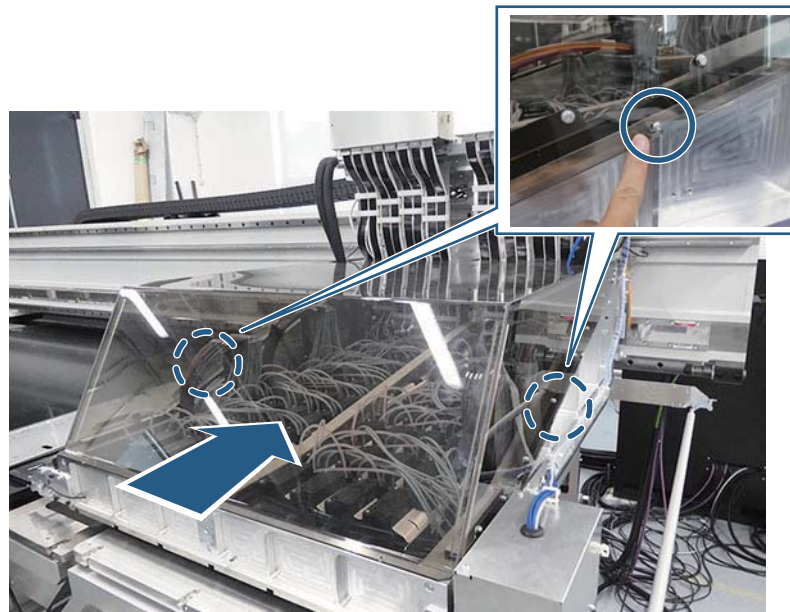

- 29** Attach the print head cover, and then tighten the screws on the left and right sides of the print head cover (1 screw each) using the hex key (width: 3 mm).

**CAUTION:**

Do not apply excessive force to the print head cover. Doing so may damage the print head cover.



- 30** Tighten the screws on the front side of the print head cover (4 screws) using the hex key (width: 3 mm).



- 31** When the front cover (Home) is open, check to see if the display of the control PC has been moved to the outer side.

If it has not been moved, move the display of the control PC to the outer side.

32 Close the front cover (Home or Full).

33 If the display of the control PC has been moved to the outer side, return the control PC to its original position.

34 Turn the main power switch on the main electric box to 1 (On).

35 After confirming that the light is flashing, press the Confirm button on the front side of the machine.

36 If a message is displayed on the screen of the control PC, press [Return to Origin].

The signal lamp flashes green and the return to origin operation begins.

After return to origin operation is complete, the signal lamp will light up green, and the screen for operating the machine will appear.

37 On the screen of the control PC, press [Prepare to Replace Head] on the [Head Replacement] tab in the [Maintenance] menu.

When replacing a print head on the opposite side, press [Head Maintenance] - [Move to Home]/[Move to Full]. Proceed to Procedure 3 in the "[Preparing to Replace the Head](#)" on page 260.

To end the replacement procedure, press [Next].

A blue check mark will appear indicating that the [Prepare to Replace Head] procedure is complete, and you will be taken to the [Select Replaced Head] screen.

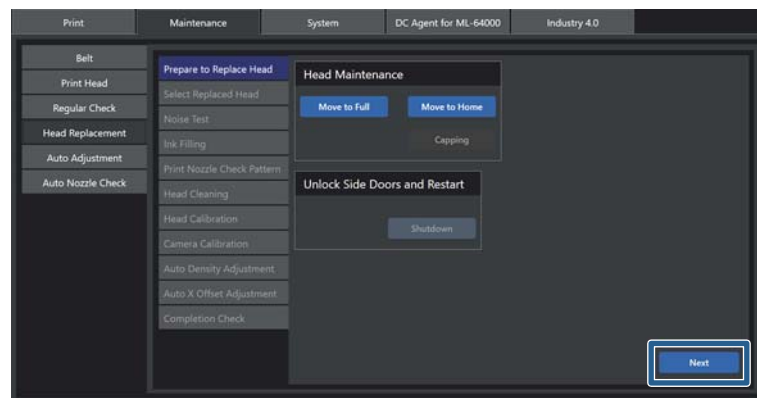

Selecting the Head for Replacement

Confirm that the replaced print head appears here.

A blue check mark and a warning mark will appear next to the replaced print head.

If all replaced print heads appear here, press [Next].

A blue check mark will appear indicating that the [Select Replaced Head] procedure is complete, and you will be taken to the [Noise Test] screen.

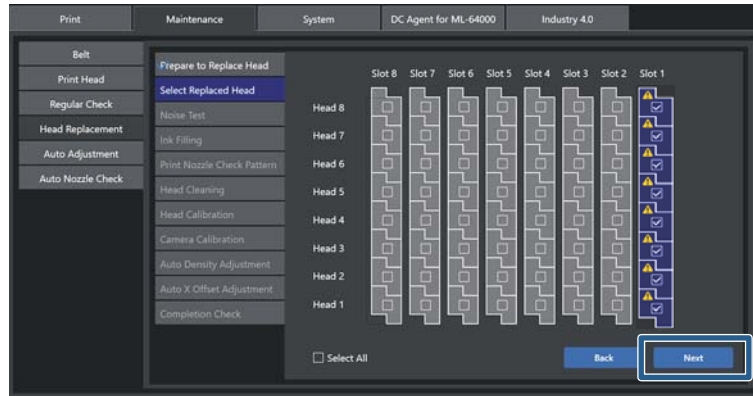

To replace an additional print head besides the print head already replaced, press [Back], or press [Prepare to Replace Head] in the [Head Replacement] tab, and then restart the procedure from preparations for replacing the print head.

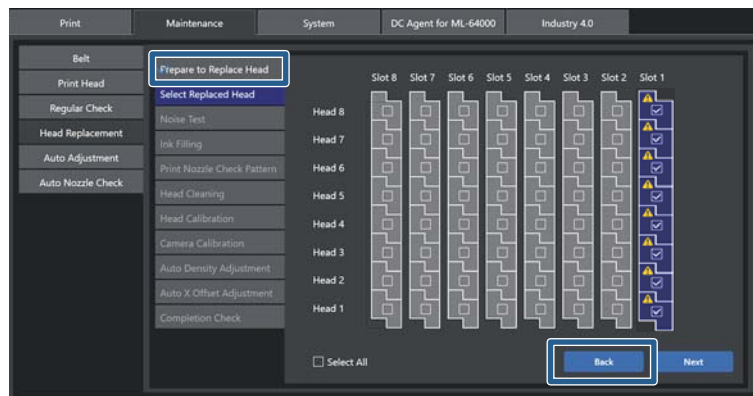

Noise Test

Confirm that the replacement print heads are connected.

1 Press [Noise Test] - [Start].

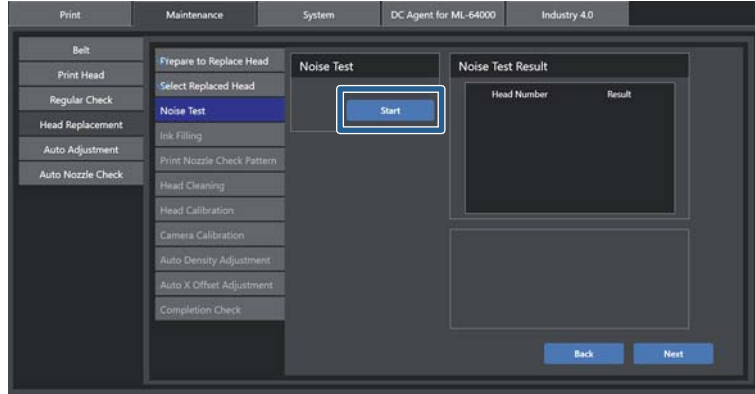

2 Confirm the [Noise Test Result].

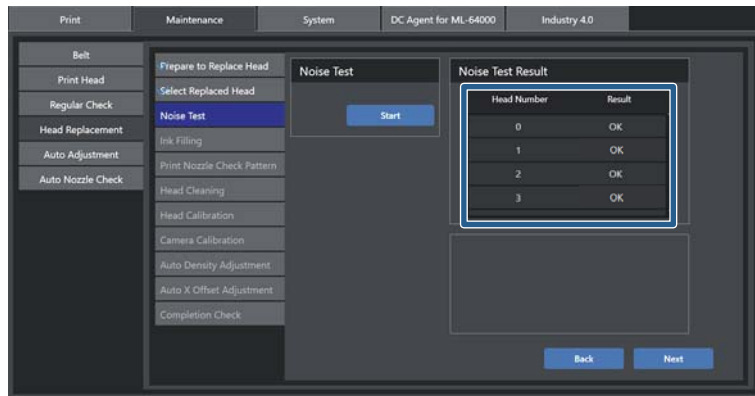

If any of the [Result] are [Fail], confirm the failure message that appears on the bottom right of the [Noise Test] tab, and address the issue accordingly.

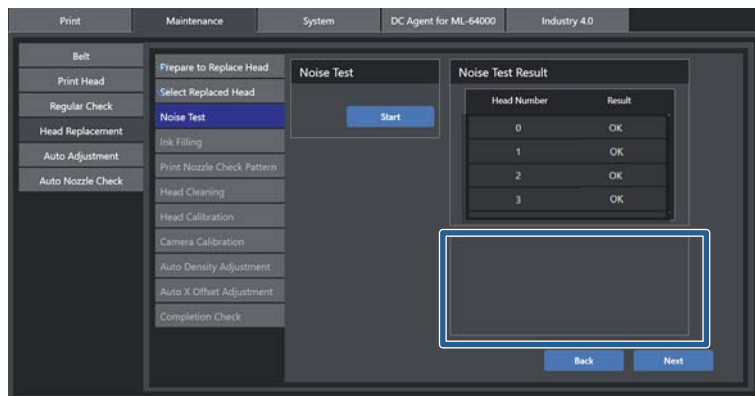

If all [Result] are [OK], press [Next].

A blue check mark will appear indicating that the [Noise Test] procedure is complete, and you will be taken to the [Ink Filling] screen.

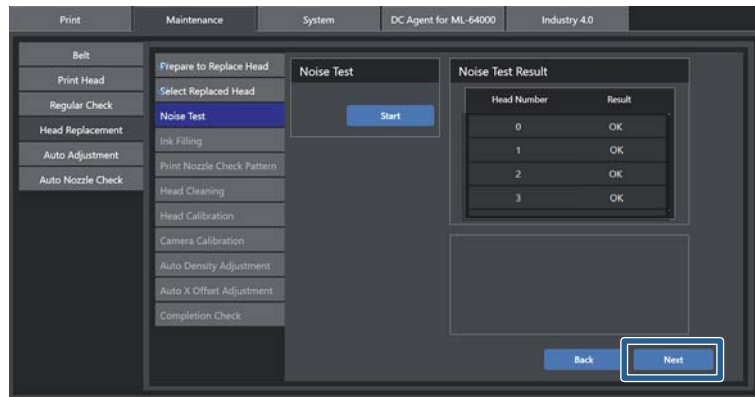

Ink Filling

The replacement print heads will be filled with ink.

A check mark will automatically appear for the replacement print head ink array.

Note:

- The color bars represent the ink arrangement of the print head.
- Color bars will appear when the print head has been filled.
- If color bars do not appear, ink filling has not finished.

Print head that has finished filling

Print head that has not finished filling

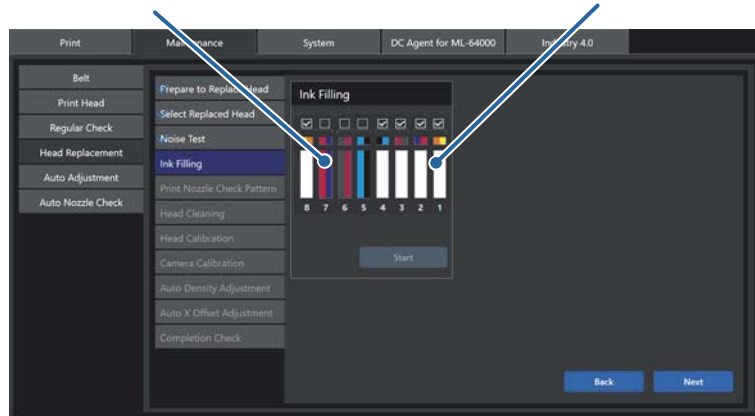

1 Press [Ink Filling] - [Start].

This will begin filling the replacement print heads with ink.

Color bars representing the ink colors will appear when ink filling is complete, and the [Next] button will become available.

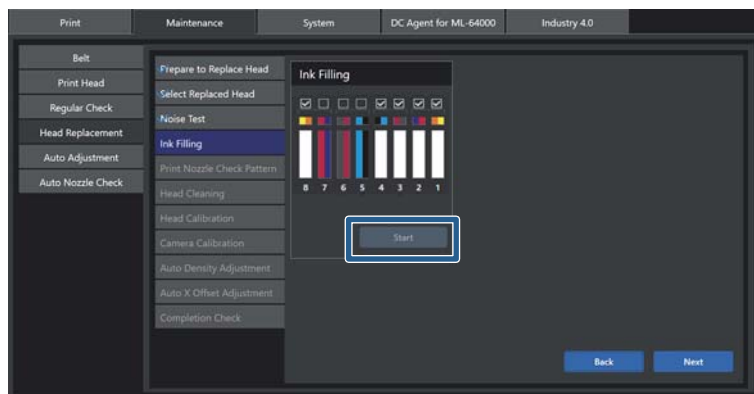

2 Press [Next].

A blue check mark will appear indicating that the [Ink Filling] procedure is complete, and you will be taken to the [Print Nozzle Check Pattern] screen.



Printing the Nozzle Check Pattern

Print the check pattern. Inspect the printed check pattern visually to determine whether the nozzles are clogged.

Note:

Use cut sheets for the nozzle check, because the ink grains are very fine. Fabric can also be used, but makes it difficult to determine if there are clogged nozzles.

Required items:

- Plastic board (bundled item)
- A3 plus (480 x 360 mm) cut sheet x 2 (commercially available)

Setting the Cut Sheets

This procedure is not necessary when printing directly on fabric.

- 1 Place the cut sheets on the plastic board as shown in the image below.



- 2 Change the direction of the plastic board and position it 180 mm from the right edge of the belt on the front of the machine.

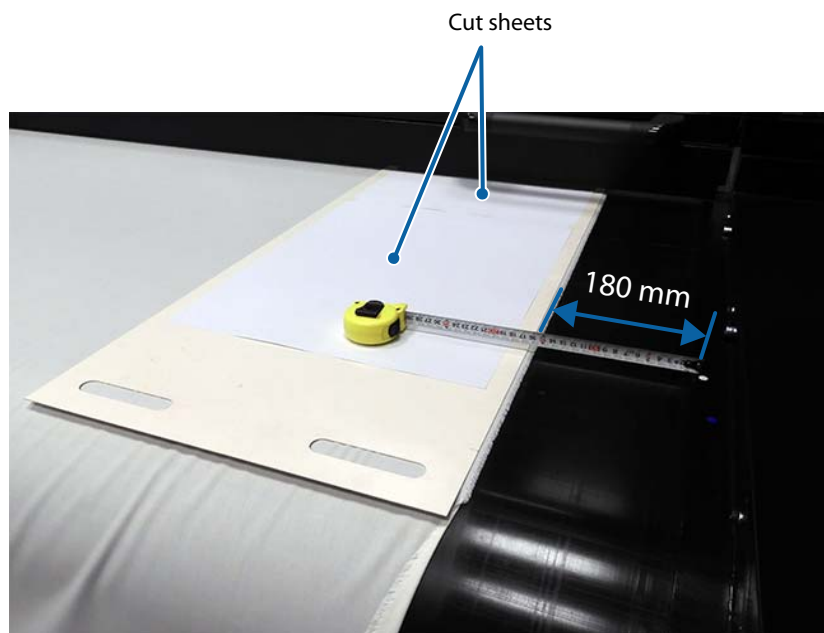

Printing the Nozzle Check Pattern

1 Select [Maintenance] menu - [Print Head] tab on the screen of the control PC.

2 Configure the settings below under Print Nozzle Check Pattern.

Print start position: 130 mm

Fabric thickness: 1.3 mm (thickness of plastic board)

Head height: 0.7 mm (recommended value)

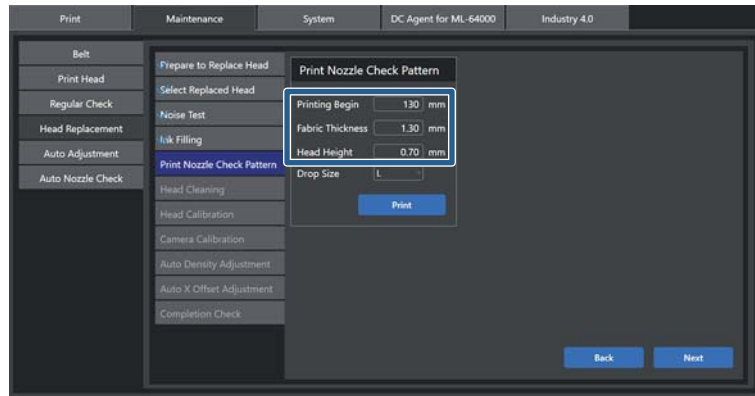

3 Move the plastic board to the printing area.

Press the backfeed button to move the plastic board, and align the edge of the printing area in the Y direction with the edge of the paper.



WARNING:

Make sure the plastic board and cut sheets do not lift up or bend.

If the plastic board or cut sheets lift up or bend, the print head might hit them and become damaged when printing.

4 Press [Print] to print the nozzle check pattern.

When printing is complete, "Standby" is displayed for the status, and the signal lamp turns green.

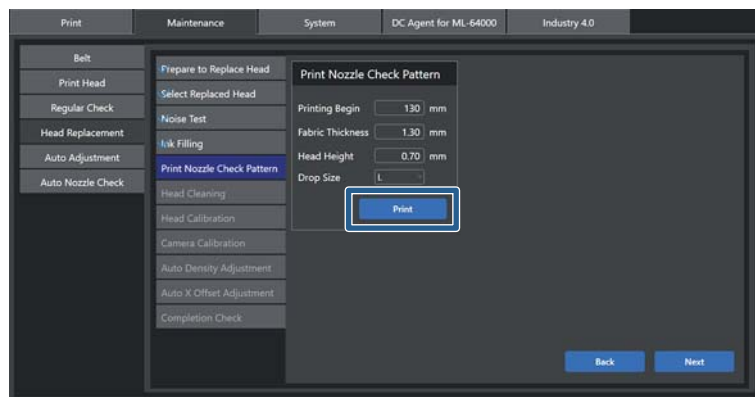

- 5 Press the feed button on the front panel to feed the belt and bring the plastic board forward.
- 6 Lift up the plastic board, and then press [Next].
A blue check mark will appear indicating that the [Print Nozzle Check Pattern] procedure is complete, and you will be taken to the [Head Cleaning] screen.

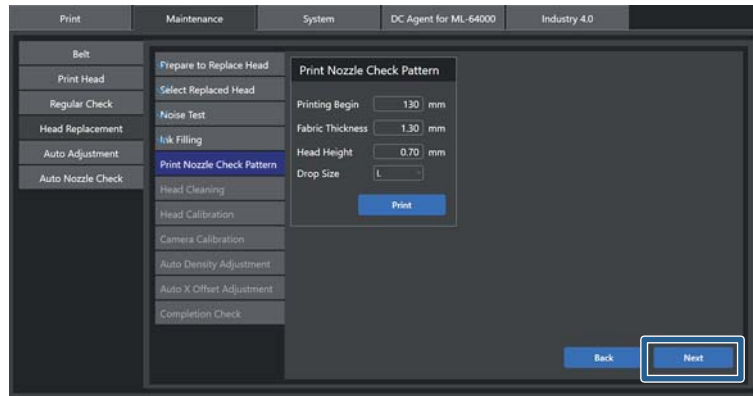

Head Cleaning

Clean print heads with clogged nozzles.

Check the nozzle check pattern that is printed.

If nozzle clogging has not occurred and all lines print clearly, press [Next].

A blue check mark will appear indicating that the [Head Cleaning] procedure is complete, and you will be taken to the [Head Calibration] screen.

If there are clogged nozzles (there are areas that are not printed), perform head cleaning.

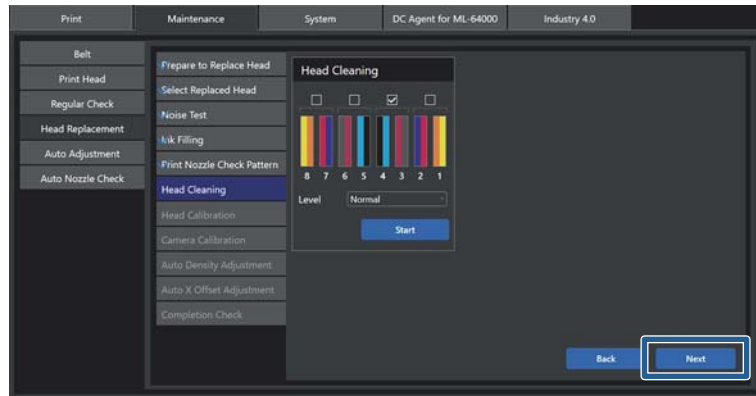

1 Place a check mark for replacement print heads with clogged nozzles.

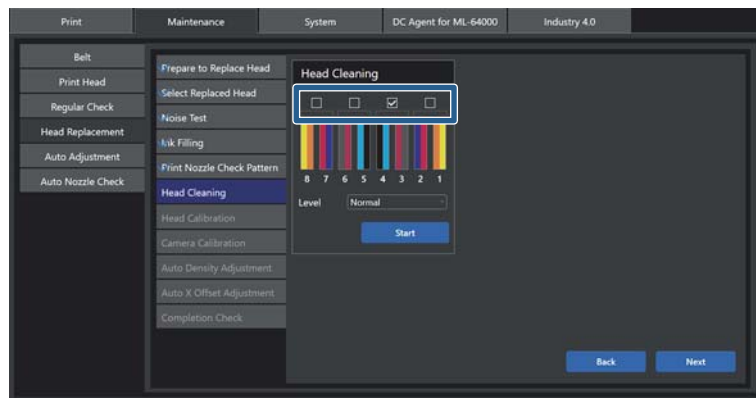

2 Set the cleaning [Level] as necessary, and then press [Start].

"Cleaning" is displayed for the status. When head cleaning is complete, "Standby" is displayed for the status.

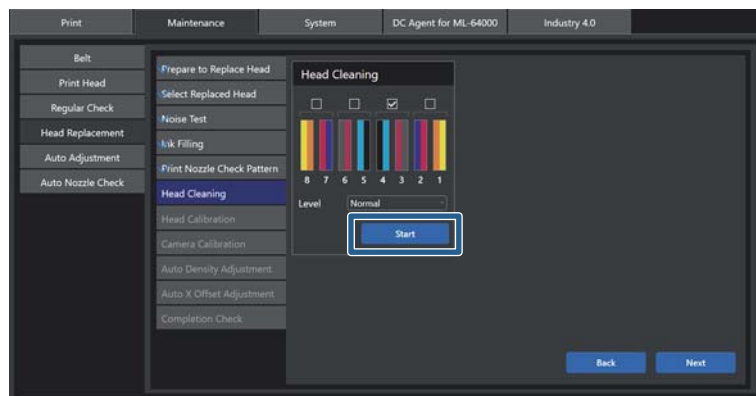

3 Press [Back] or [Print Nozzle Check Pattern] to print the nozzle check pattern again.

Note:

If there are clogged nozzles (there are areas that are not printed) even after head cleaning, contact your dealer or Epson Support.

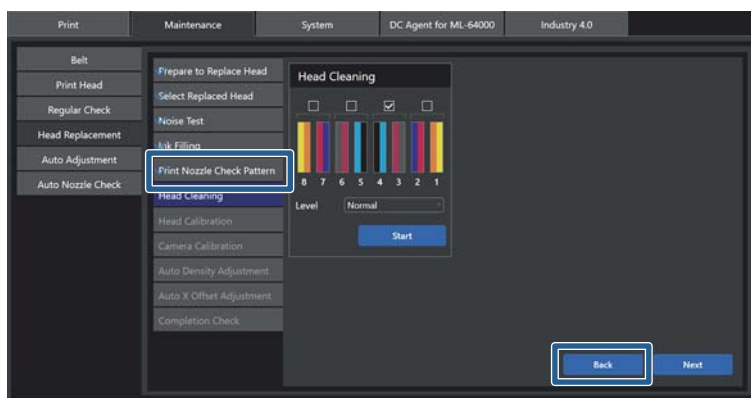

Head Calibration

Print heads are calibrated automatically. Check the calibration results to confirm whether default settings have been set for replacement print heads.

1 Press [Head Calibration] - [Start].

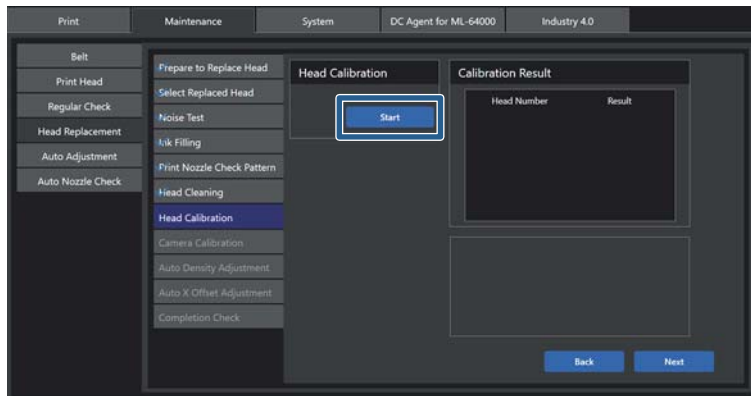

2 If the calibration results appear in [Calibration Result], the inspection is complete.

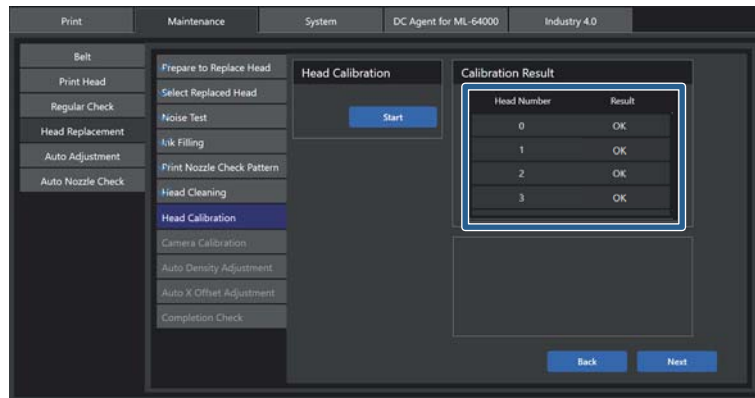

If any of the [Result] are [Fail], confirm the failure message that appears on the bottom right of the [Head Calibration] tab, and address the issue accordingly.

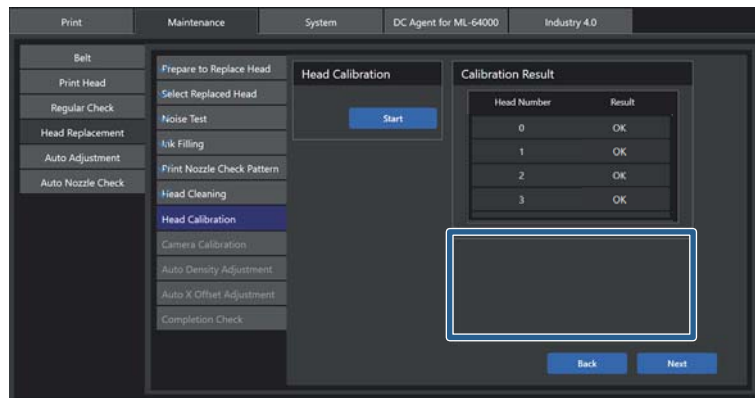

If all [Result] are [OK], press [Next].

A blue check mark will appear indicating that the [Head Calibration] procedure is complete, and you will be taken to the [Camera Calibration] screen.

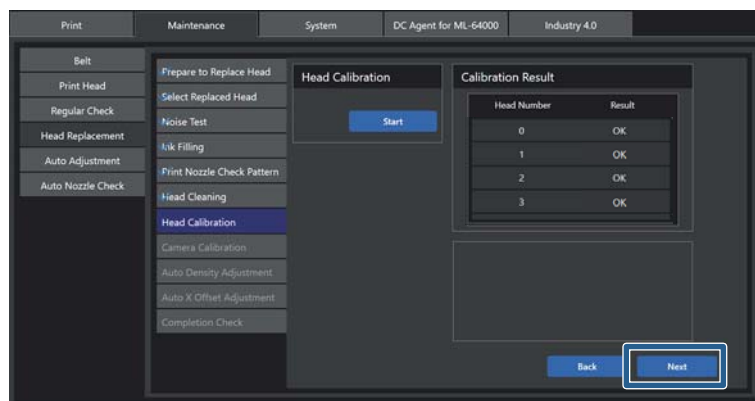

Camera Calibration

The image quality adjustment camera will be calibrated automatically. Confirm the calibration results.

Required items	<ul style="list-style-type: none"> • A2 (594 × 420 mm) size photography paper x 1 (commercially available) • Rollers (commercially available) Epson recommends using rubber.
----------------	--

CAUTION:

Use the same photography paper for camera calibration, automatic density adjustment, and automatic X offset adjustment.

Failure to do so may lead to banding (horizontal bands, uneven shading, and streaking) or issues in each adjustment.

- 1** From the control PC, open the [Print] menu and confirm that [Print Settings] - [Device Settings] - [Belt Cleaning] and [Pressure Roller] are not selected (1) or are grayed out (2).

If [Belt Cleaning] and [Pressure Roller] are not grayed out and are selected, unselect [Belt Cleaning] and [Pressure Roller], or select [Cut Sheet Mode].

Belt cleaning and the pressure roller will no longer operate even if the feed button is pressed.

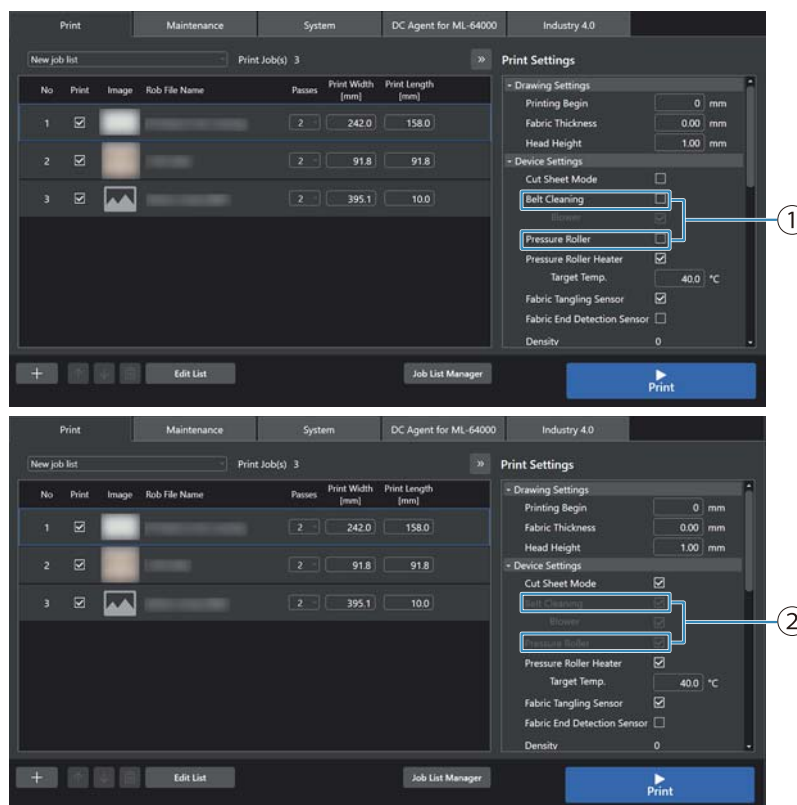

- 2** Confirm that the pressure roller has stopped at the front.

If the pressure roller has stopped at the rear, turn the pressure roller switch to the right (Swing) to move the pressure roller. When it has moved to the front, turn the switch back to its original position.

- 3** Wipe the belt surface with a soft cloth soaked in water and thoroughly wrung out. This prevents the photo paper from sticking to the belt. Wipe off any dust or lint on the belt surface.
- 4** Place the top edge of the photo paper vertically, 710 mm from the edge of the belt.

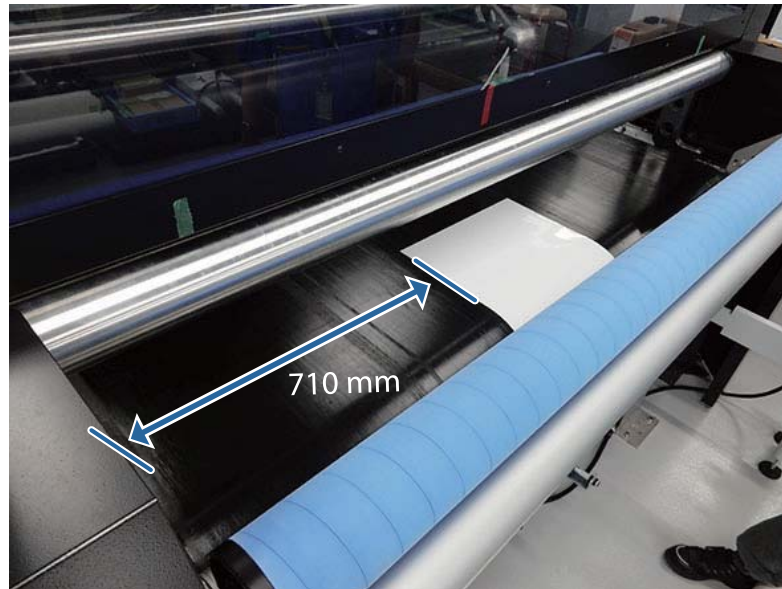

- 5** Move the rollers back and forth from the rear to attach the top of the photo paper cleanly to the belt so that there are no wrinkles or curls.



- 6** Press and hold the Feed button on the rear panel to rotate the belt in the forward direction until the bottom of the photo paper is attached to the belt.

- 7** Move the rollers to the rear to attach the bottom of the photo paper cleanly to the belt so that there are no wrinkles or curls.



- 8** Press the feed button on the rear panel so that the edge of the photography paper is fed to the threaded hole on the far rear side of the pressure roller platen on the rear Home side.

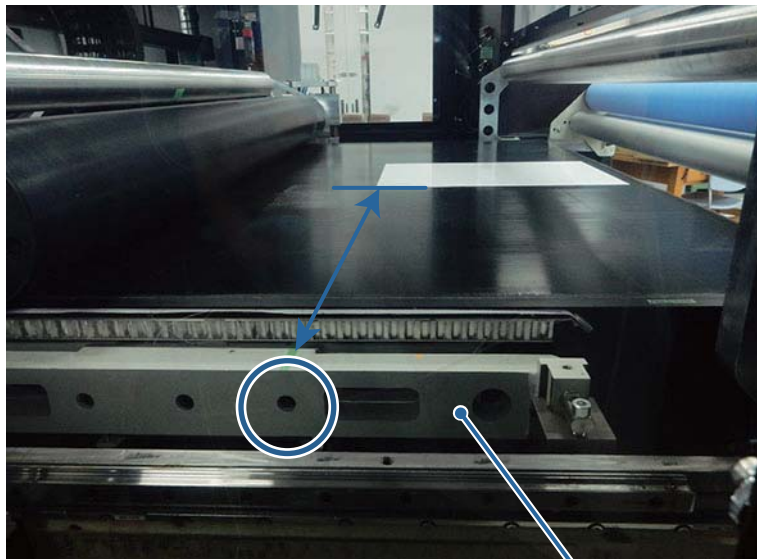

Pressure roller platen

- 9** Press [Auto Belt Rotation] - [Reset].
The specified value is displayed.

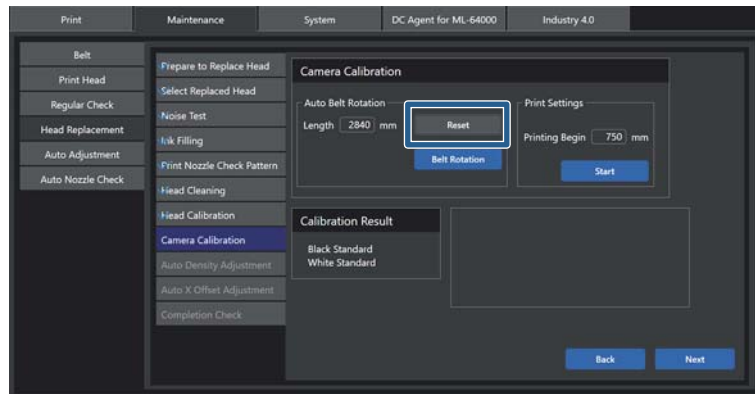

- 10** Press [Belt Rotation].
The photography paper will be fed to the printing position.

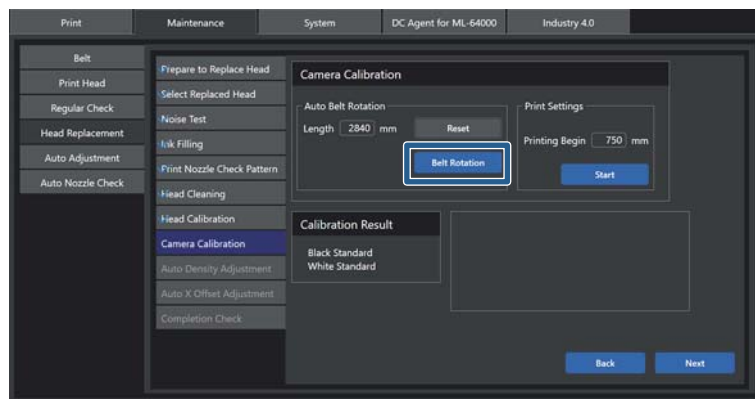

- 11** Set the [Printing Begin] position to 750 mm.

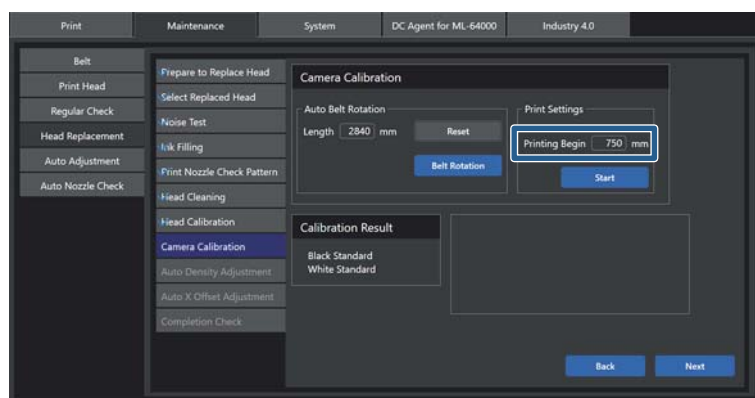

- 12** Press [Camera Calibration] - [Start].
The [Calibration Result] is displayed when the calibration is complete.

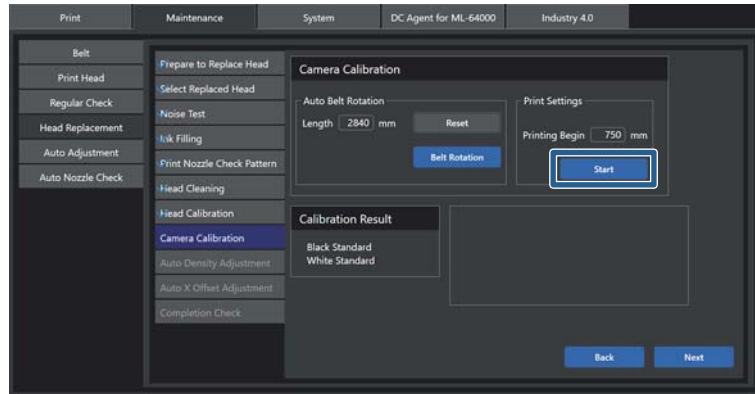

13 Confirm the [Calibration Result].

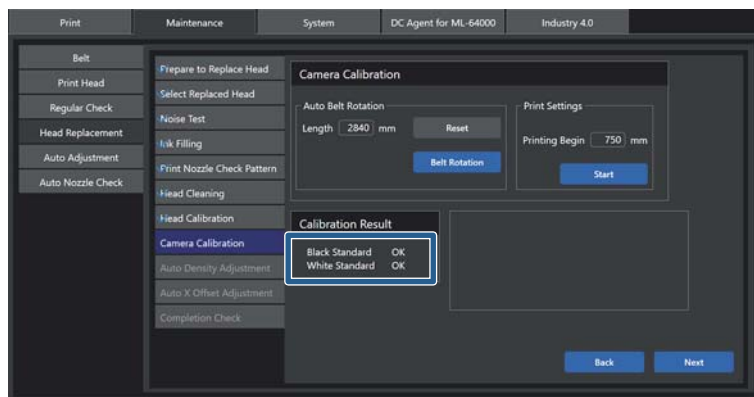

If any of the [Calibration Result] are [Fail], confirm the failure message that appears on the bottom right of the [Camera Calibration] tab, and address the issue accordingly.

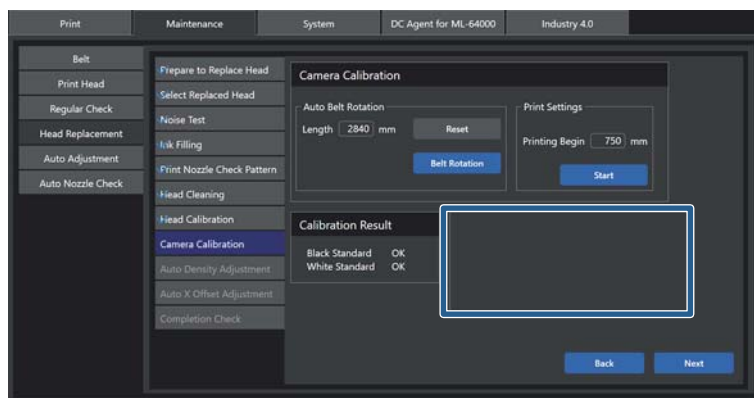

If all [Calibration Result] are [OK], press [Next].

A blue check mark will appear indicating that the [Camera Calibration] procedure is complete, and you will be taken to the [Auto Density Adjustment] screen.

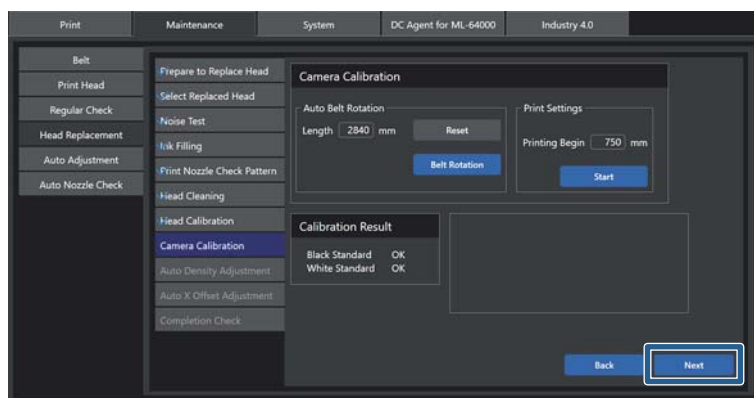

Auto Density Adjustment

This prints a pattern for automatically creating and updating values for correcting the difference in density for each print head.

Required items	<ul style="list-style-type: none"> • A2 (594 × 420 mm) size photography paper x 1 (commercially available) • Rollers (commercially available) Epson recommends using rubber.
----------------	--



CAUTION:

Use the same photography paper for camera calibration, automatic density adjustment, and automatic X offset adjustment.

Failure to do so may lead to banding (horizontal bands, uneven shading, and streaking) or issues in each adjustment.

- 1 From the control PC, open the [Print] menu and confirm that [Print Settings] - [Device Settings] - [Belt Cleaning] and [Pressure Roller] are not selected (1) or are grayed out (2).

If [Belt Cleaning] and [Pressure Roller] are not grayed out and are selected, unselect [Belt Cleaning] and [Pressure Roller], or select [Cut Sheet Mode].

Belt cleaning and the pressure roller will no longer operate even if the feed button is pressed.

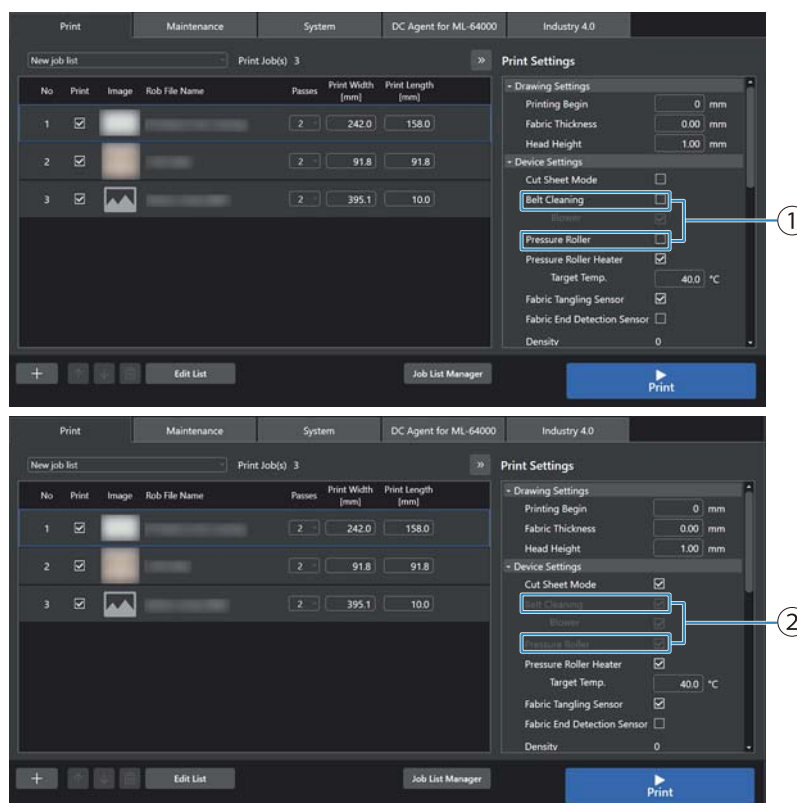

- 2 Confirm that the pressure roller has stopped at the front.

If the pressure roller has stopped at the rear, turn the pressure roller switch to the right (Swing) to move the pressure roller. When it has moved to the front, turn the switch back to its original position.

- 3** Wipe the belt surface with a soft cloth soaked in water and thoroughly wrung out. This prevents the photo paper from sticking to the belt. Wipe off any dust or lint on the belt surface.
- 4** Place the top edge of the photo paper vertically, 710 mm from the edge of the belt.

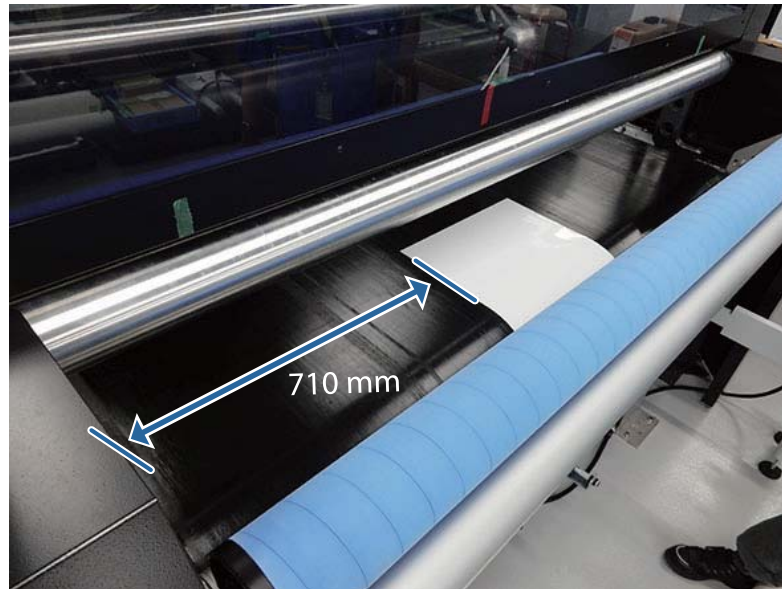

- 5** Move the rollers back and forth from the rear to attach the top of the photo paper cleanly to the belt so that there are no wrinkles or curls.



- 6** Press and hold the Feed button on the rear panel to rotate the belt in the forward direction until the bottom of the photo paper is attached to the belt.

- 7** Move the rollers to the back of the photo paper to attach the bottom of the photo paper cleanly to the belt so that there are no wrinkles or curls.



- 8** Press the feed button on the rear panel so that the edge of the photography paper is fed to the threaded hole on the far rear side of the pressure roller platen on the rear Home side.

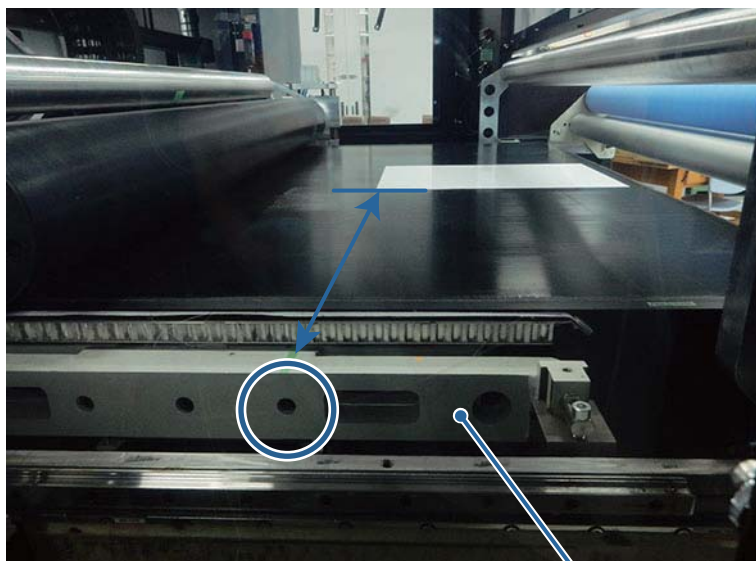

Pressure roller platen

9 Select the pattern to print from [Pattern] in [Auto Printing and Auto Imaging].

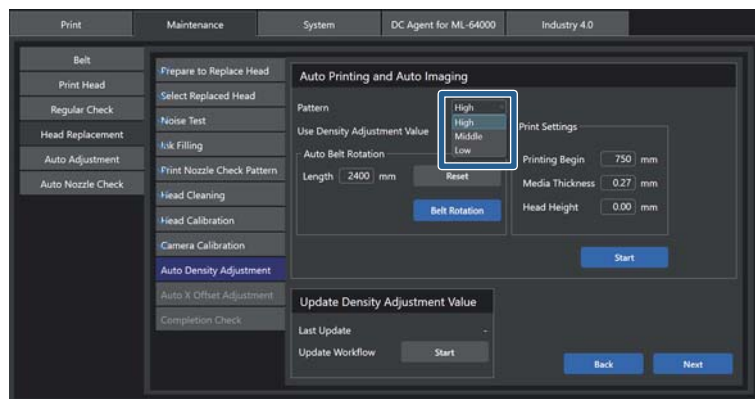

10 Press [Auto Belt Rotation] - [Reset]. The specified value is displayed.

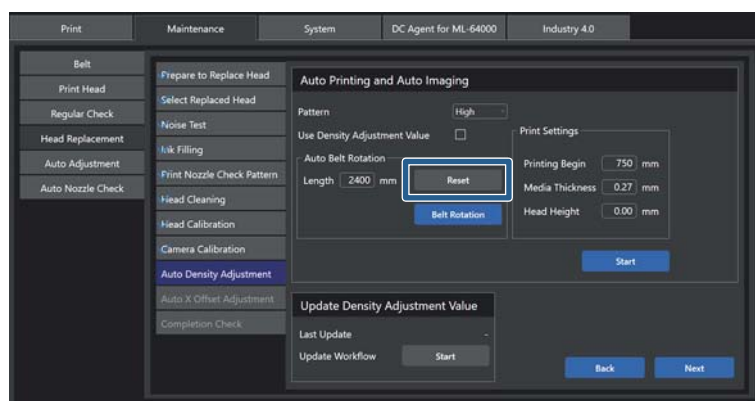

11 Press [Belt Rotation]. The photography paper will be fed to the printing position.

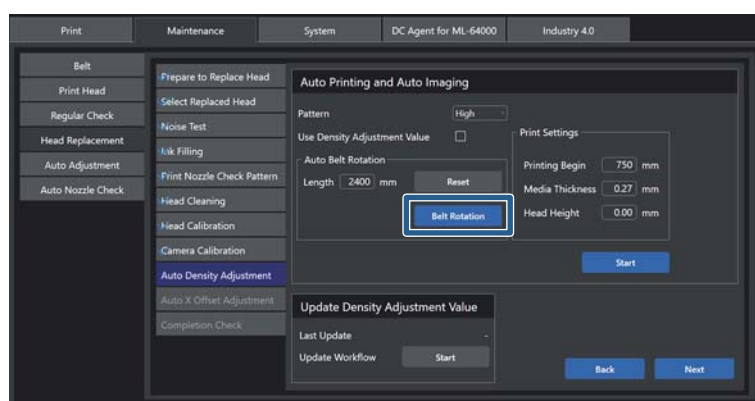

12 Configure the following settings in [Print Settings].

Printing Begin: 750 mm

Media Thickness: 0.27 mm (thickness of photography paper)

Head Height: 0.00 mm

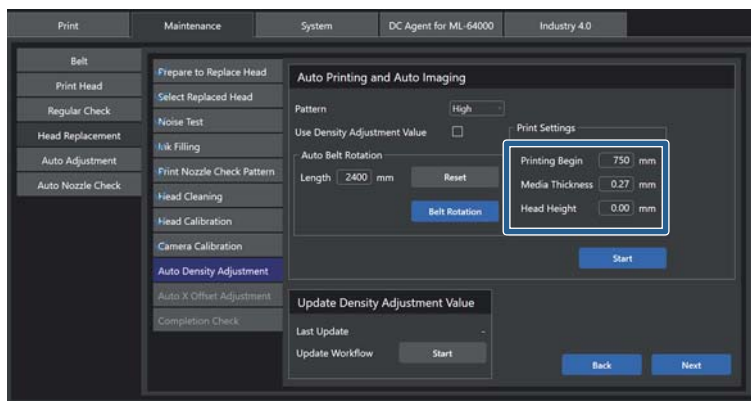
**13** Press [Start].

Print the selected pattern, and then capture an image.

Note:

If an automatic density adjustment failed message appears, confirm that the position of the photography paper and [Printing Begin] position are correct, and restart the sequence from Procedure 2.

If automatic density adjustment continues to fail after restarting the procedure, contact your dealer or Epson Support.

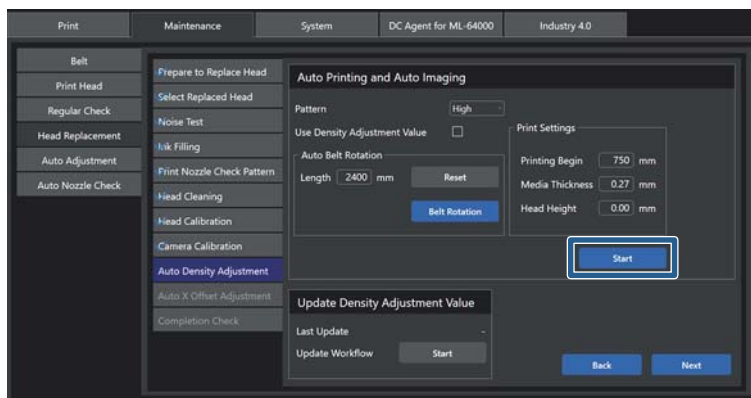
**14** Return to Procedure 2, and print a pattern other than the pattern already printed.**Note:**

Print all High, Middle, and Low patterns.

15 Once all patterns have been printed and image captures are complete, press [Update Density Adjustment Value] - [Update Workflow] - [Start].

This will update the density adjustment value.

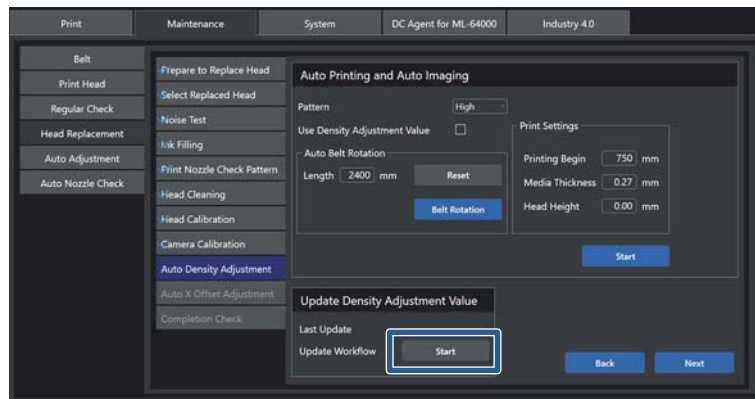

16 Press [Next].

A blue check mark will appear indicating that the [Auto Density Adjustment] procedure is complete, and you will be taken to the [Auto X Offset Adjustment] screen.

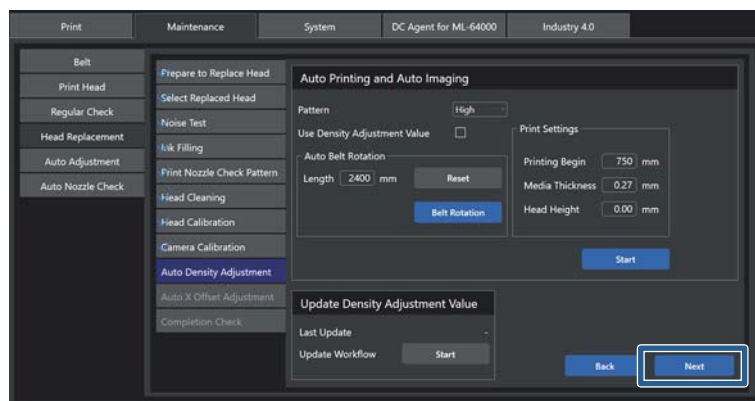

Auto X Offset Adjustment

This prints a pattern for automatically creating and updating values for correcting misalignments in ink droplet landing sites.

Required items	<ul style="list-style-type: none"> A2 (594 x 420 mm) size photo paper (commercially available) Use one sheet for each pattern printed. Rollers (commercially available) Epson recommends using rubber.
----------------	--



CAUTION:

Use the same photography paper for camera calibration, automatic density adjustment, and automatic X offset adjustment.
Failure to do so may lead to banding (horizontal bands, uneven shading, and streaking) or issues in each adjustment.

- From the control PC, open the [Print] menu and confirm that [Print Settings] - [Device Settings] - [Belt Cleaning] and [Pressure Roller] are not selected (1) or are grayed out (2).

If [Belt Cleaning] and [Pressure Roller] are not grayed out and are selected, unselect [Belt Cleaning] and [Pressure Roller], or select [Cut Sheet Mode].

Belt cleaning and the pressure roller will no longer operate even if the feed button is pressed.

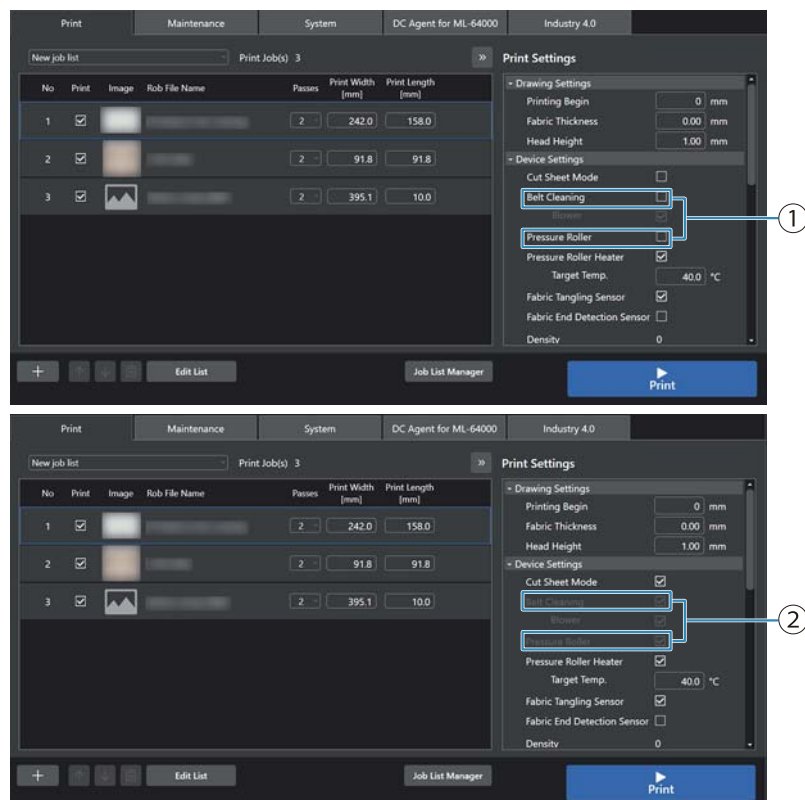

- 2 Confirm that the pressure roller has stopped at the front.**
If the pressure roller has stopped at the rear, turn the pressure roller switch to the right (Swing) to move the pressure roller. When it has moved to the front, turn the switch back to its original position.
- 3 Wipe the belt surface with a soft cloth soaked in water and thoroughly wrung out.**
This prevents the photo paper from sticking to the belt. Wipe off any dust or lint on the belt surface.
- 4 Place the top edge of the photo paper vertically, 710 mm from the edge of the belt.**

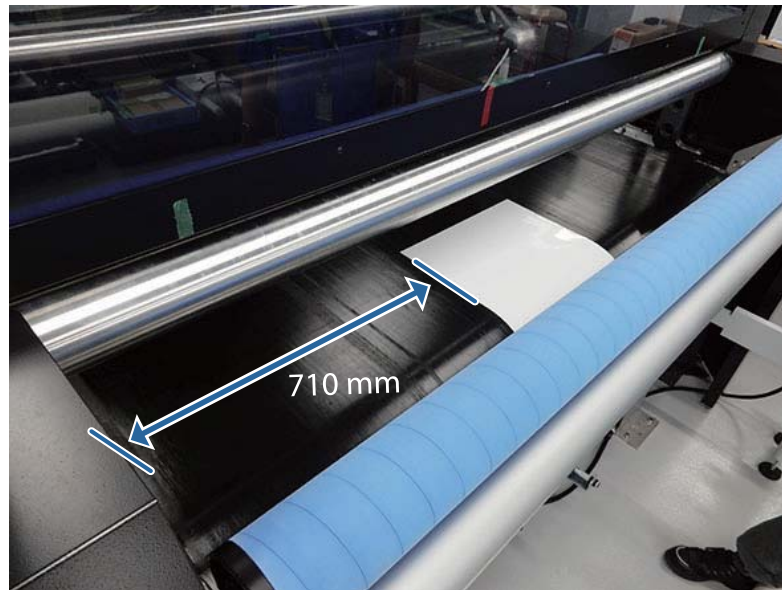

- 5 Move the rollers back and forth from the rear to attach the top of the photo paper cleanly to the belt so that there are no wrinkles or curls.**



- 6** Press and hold the Feed button on the rear panel to rotate the belt in the forward direction until the bottom of the photo paper is attached to the belt.
- 7** Move the rollers to the back of the photo paper to attach the bottom of the photo paper cleanly to the belt so that there are no wrinkles or curls.



- 8** Press the feed button on the rear panel so that the edge of the photography paper is fed to the threaded hole on the far rear side of the pressure roller platen on the rear Home side.

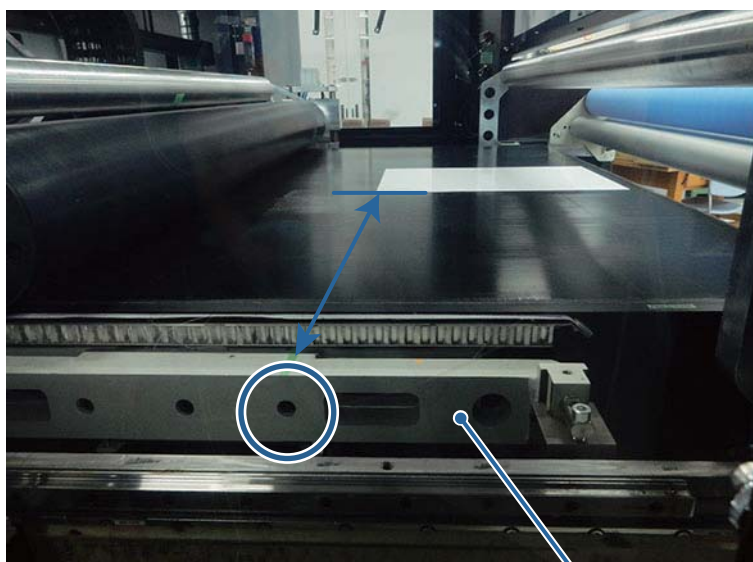

Pressure roller platen

9

Select the pattern to print from [Pattern] on the [Auto X Offset Adjustment] tab.

If the replacement print head chip is in rows 1 to 16, select [Chip1-17]. If it is in rows 17 to 32, select [Chip17-32].

Note:

When replacing multiple print heads with chips located in rows 1 to 16 and rows 17 to 32, you will need to print both patterns for [Chip1-17] and [Chip17-32]. Select and print each pattern in turn.

<Head arrangement>

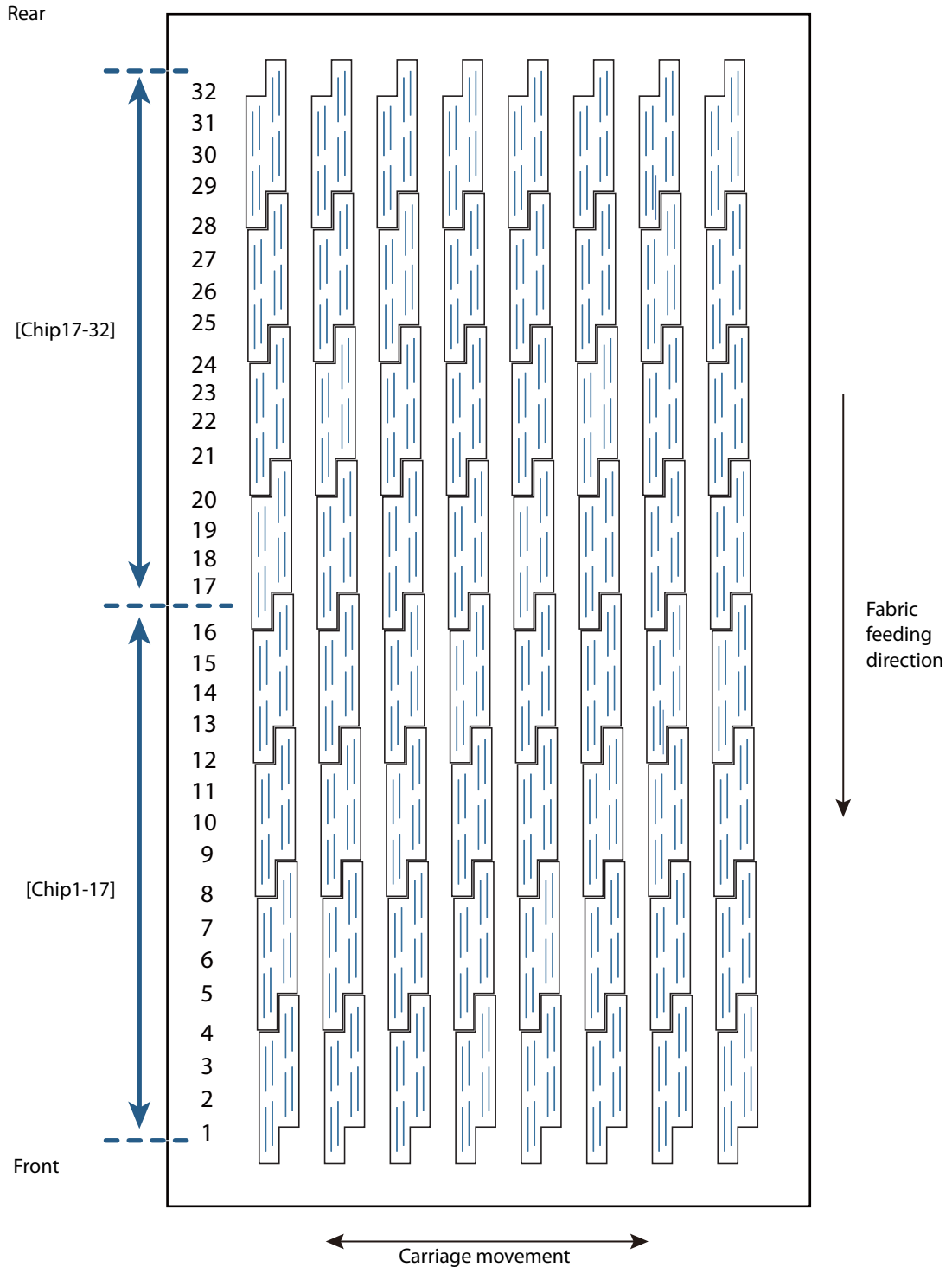

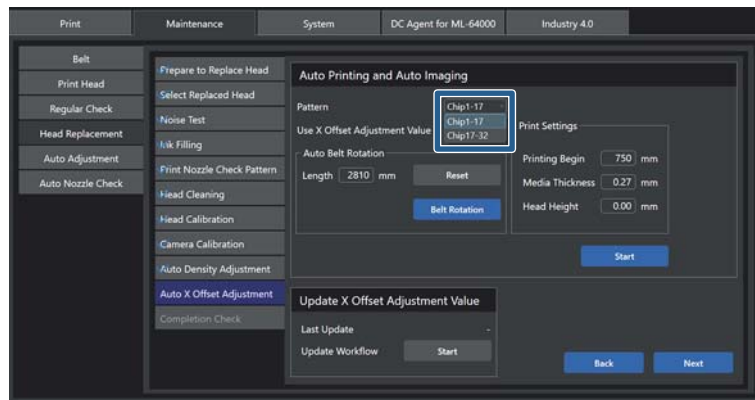

- 10** Press [Auto Belt Rotation] - [Reset].
The specified value is displayed.

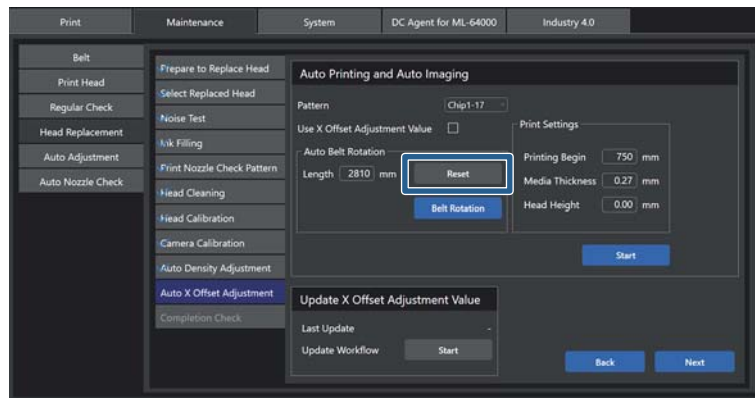

- 11** Press [Belt Rotation].
The photography paper will be fed to the printing position.

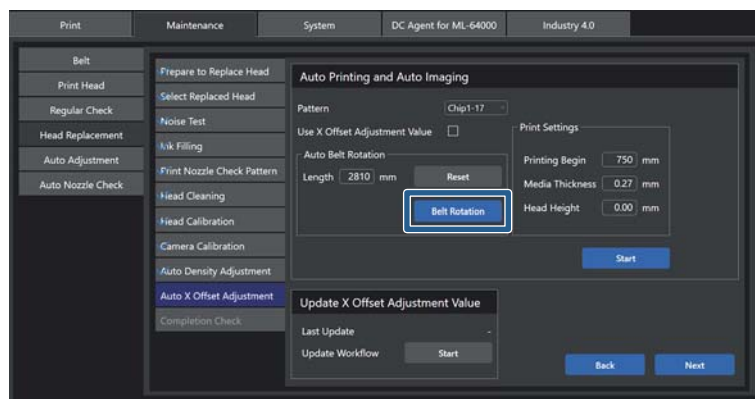

12 Configure the following settings in [Print Settings].

Printing Begin: 750 mm

Media Thickness: 0.27 mm (thickness of photography paper)

Head Height: 0.00 mm

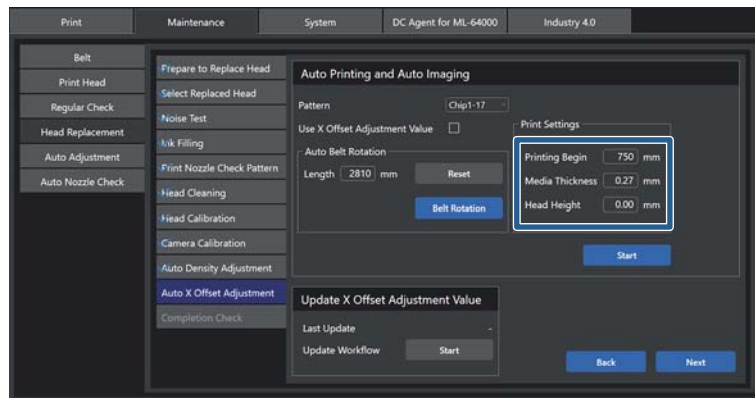

13 Press [Start].

Start printing the selected pattern and taking camera images.

Note:

If an automatic X offset adjustment failed message appears, confirm that the position of the photography paper and [Printing Begin] position are correct, and restart the sequence from step 1.

If automatic X offset adjustment continues to fail after restarting the procedure, contact your dealer or Epson Support.

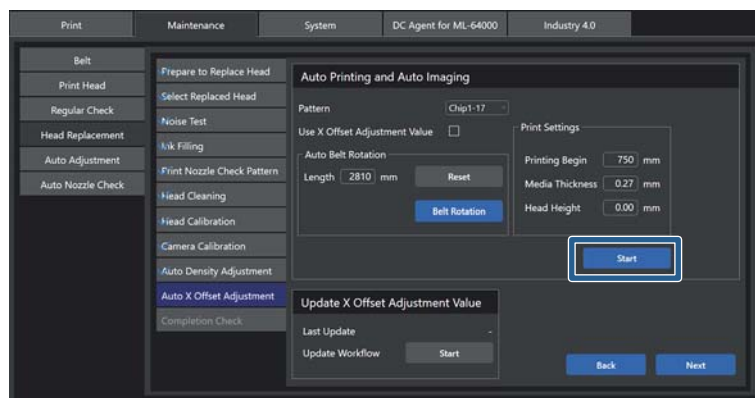

14 Press [Update Workflow] - [Start].

This will update the correction value for the X offset adjustment.

Note:

When replacing multiple print heads with chips located in rows 1 to 16 and rows 17 to 32, return to Procedure 2 and print the pattern that has not been printed.

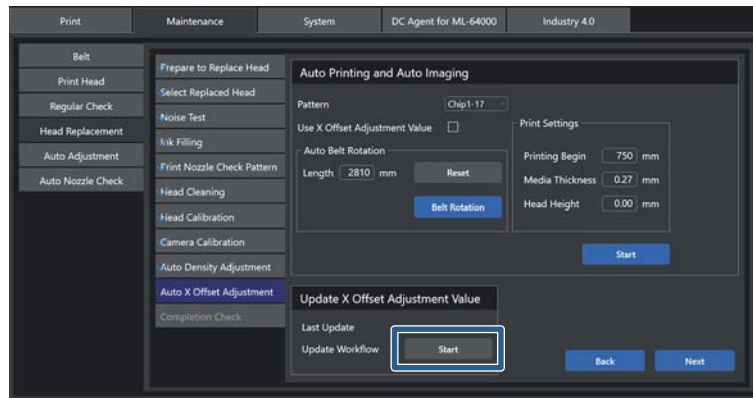
**15** Press [Next].

A blue check mark will appear indicating that the [Auto X Offset Adjustment] procedure is complete, and you will be taken to the [Completion Check] screen.

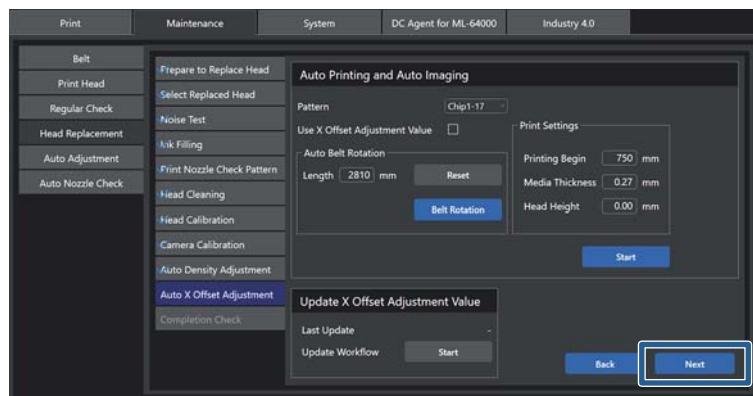

Completion Check

On the screen of the control PC, press [Finish] to confirm that the procedure is complete on the [Head Replacement] tab in the [Maintenance] menu.

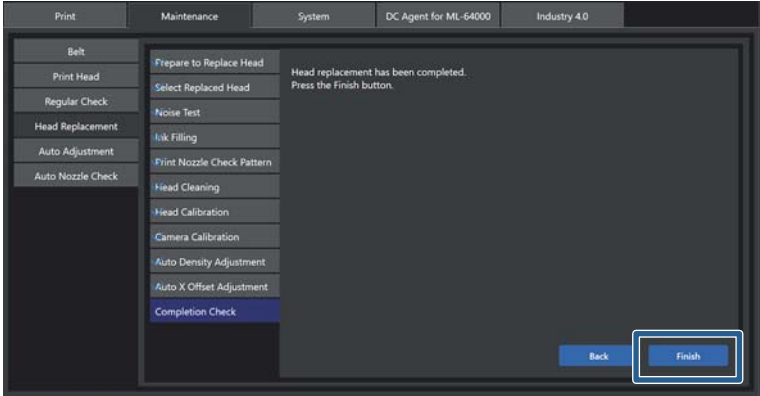

This completes the [Head Replacement] procedure.

Disposal of Used Parts

Returning the Used Print Head

Send the used print head to your dealer or Epson Support according to the procedure specified during introductory education for User Self Repair maintenance. To send the used Print Head, pack it according to the steps below, so that the ink does not leak during transport.

How to Pack

- 1** Orient the used print head as in the figure, put it in the protective case, and close the lid.
- 2** Put the protective case in the plastic bag that came with the replacement print head, and then put it all in the outer carton and seal it with adhesive tape.
Pack it securely so that the print head does not come out of the box during transport.









Problem Solver

This section describes actions to take when trouble occurs.

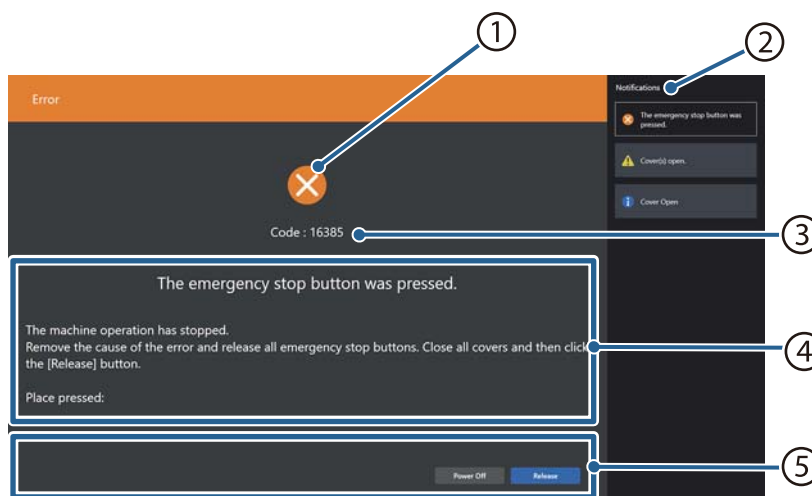
If a Message Is Displayed

When an error occurs in this machine or continuing operation would impact printing, a message appears on the control PC. If multiple notifications have occurred, they are lined up in order of importance on the right side of the screen. Click a notification, read the instructions, and then take the necessary measures.



No.	Name	Description
1	Icon	 : An error has occurred in the machine. You cannot start or continue printing or function operations. Read the instructions and take the measures described.  : If operation is continued without taking measures, you may become unable to start or continue printing or function operations. Read the instructions and take the measures described.  : The status of the machine appears in the notification section on the right side of the screen. Click to see details.
2	Notification list	Displays a list of notification information in order of importance.
3	Code number	Displays the code number. When contacting your dealer or Epson Support, be sure to include the "XXXXX" (code number).
4	Action	Displays what kind of error or warning has occurred, and the action to take for the error or warning occurring. When contacting your dealer or Epson Support, check the code number and then turn off the power to the machine. If the part ID is displayed, check the part ID as well. Do not turn the power back on again.

No.	Name	Description
5	Operation buttons	The operation buttons displayed vary depending on the message. Perform operations according to the action message.

Troubleshooting

When Printed Colors are Different

If printed colors are different from what was expected, the ink colors might be mixing. Print a check pattern to identify which ink colors are mixing, and then flush the print head(s). If you can determine from the printout which ink colors are mixing, it is not necessary to print a check pattern.

Refer to ["Nozzle Check" on page 51](#) for more information about how to print a check pattern.

Refer to ["Flushing" on page 56](#) for the flushing procedure.

Printing While the Nozzles Are Still Clogged

If you want to print while the nozzles are still clogged even after performing head cleaning several times, you can print using the four rows of print heads (32 heads) that do not have clogged nozzles.

When printing with 32 heads, productivity may drop, and you may not be able to perform auto adjustment.

- 1 Print the nozzle check pattern and specify heads with nozzles that are not clogged.**
For more information about how to print a nozzle check pattern, refer to ["Nozzle Check" on page 51](#).

In example (1), the print heads in rows 1 to 4 can be used to print.

In example (2), printing cannot be performed by reducing the print heads. Perform nozzle surface cleaning.

Refer to ["Cleaning the Head Nozzle Surface \(Clean Stick\)" on page 245](#) for the procedure.

The following describes the procedure for printing using the print heads in rows 1 to 4.

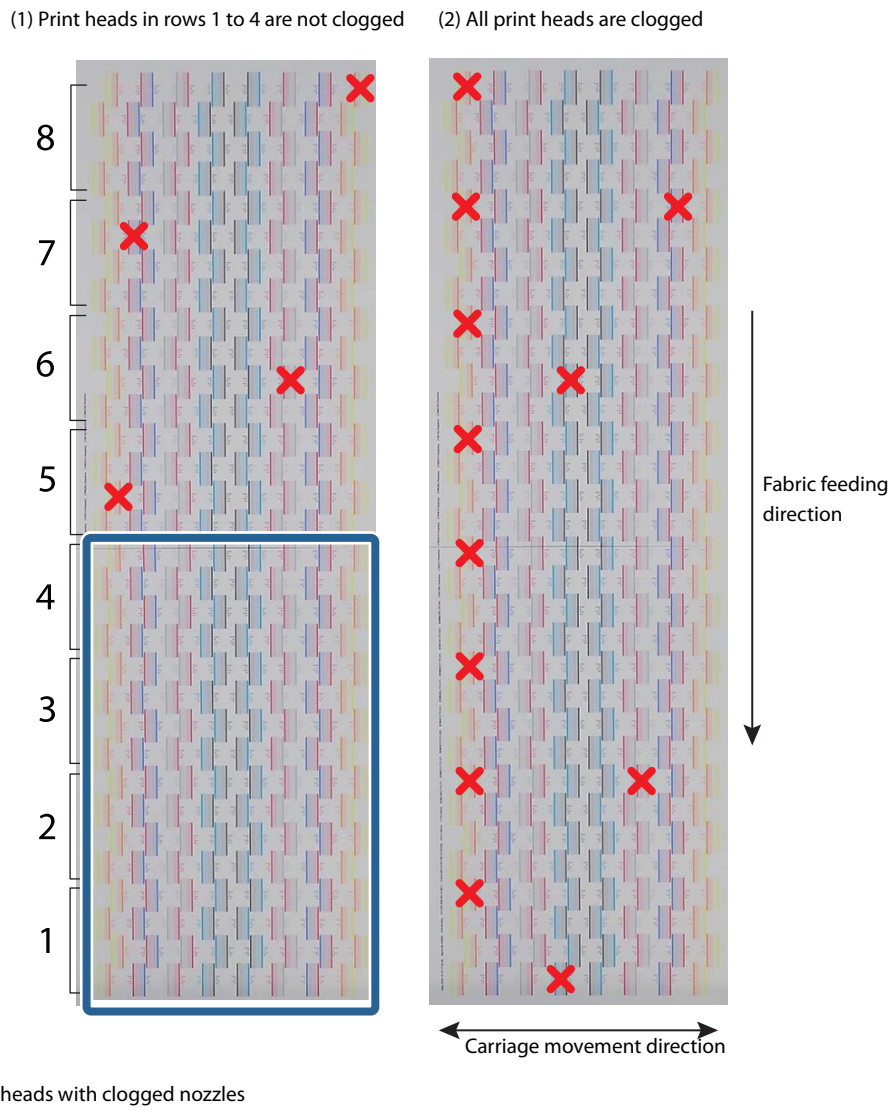

2 On the control PC, press the [System] menu, and then the [Head] tab.

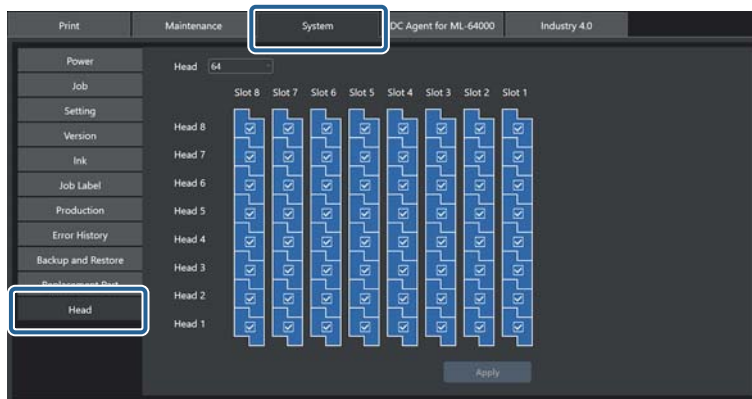

3 Select [Head], and then [32].

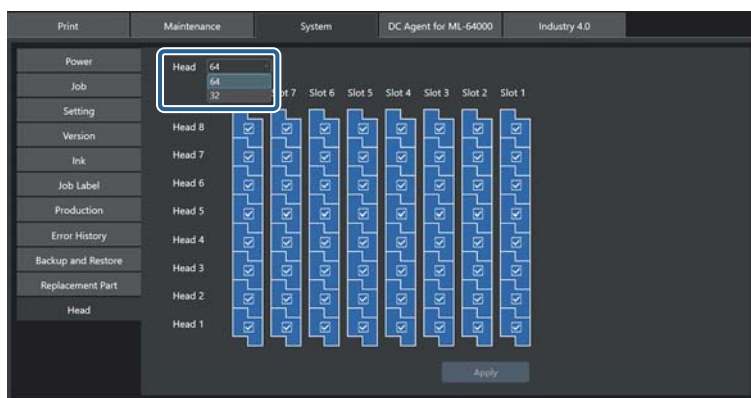

4 From [Pattern], select the rows of print heads which do not have clogged nozzles to be used for printing.

In example (1), select [Head1-4]. The selected print heads are displayed in blue and a check mark will appear.

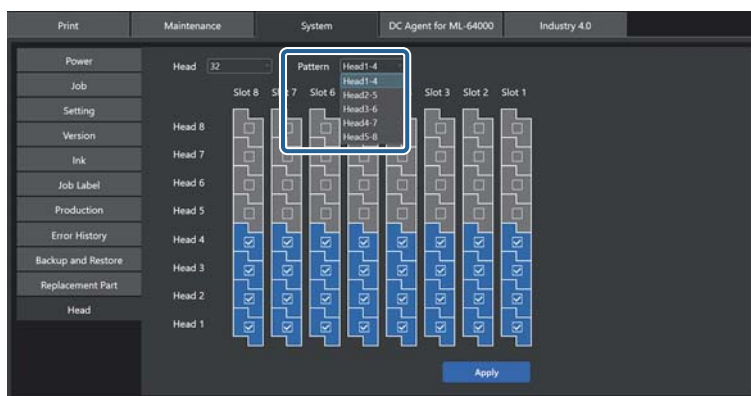

5 Press [Apply].

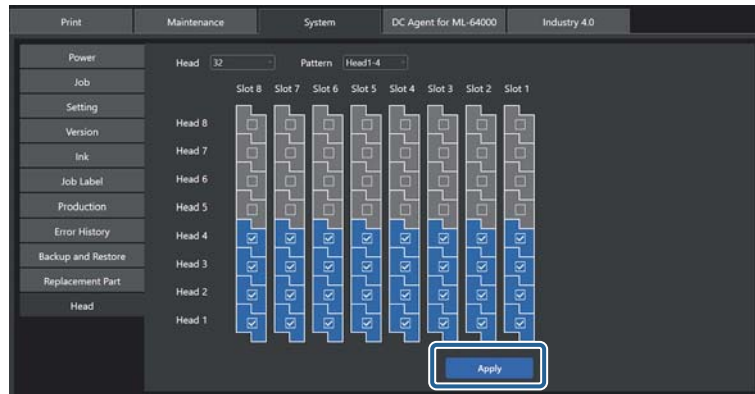

If you want to print using all the print heads, select [Head] and then [64], and then press [Apply].

Specifications

This section describes the specifications for the ML-64000-180.

Basic Specifications

Item	Specifications	Notes
Print head	On-demand ink jet	8-color
Compatible inks	"Supported Ink" on page 317.	
Printing resolution	X: Scanning direction, Min. 600 dpi to Max. 1200 dpi Y: Fabric feed direction, Min. 600 dpi to Max. 1200 dpi	
Print speed	740 m ² /h	
Max. printing width	1,800 mm	
Color number	8-color	
Ink pack	1 color/1 pack	
Ink pack capacity	10 liters	
Sound pressure level	70 dB(A) or less	During printing
Printer operating environment	Temperature: 20 to 30°C Humidity: 40 to 60 % RH (no condensation)	
Recommended printing environment	Temperature: 22 to 28°C Humidity: 40 to 60 % RH (no condensation)	
Printer storage environment	Store the printer filled with ink. Temperature: 0 to 40°C Up to 1 month Must not be any condensation	
Device dimensions	Printer: 6,500 (W) x 4,960 (D) x 2,530 (H) mm Main electric box: 1,600 (W) x 1,200 (D) x 2,635 (H) mm (including signal lamp) 1,600 (W) x 1,200 (D) x 2,473 (H) mm (not including signal lamp) Ink rack: 1,760 (W) x 960 (D) x 840 (H) mm	Not including the feeding unit, winding, and drying areas.
Equipment weight	Printer: Approx. 7,000 kg Main electric box: Approx. 700 kg Ink rack: Approx. 300 kg (not including ink cartridges)	

Printing Width

Item		Specifications
Printable fabric width	Scan direction (x)	300 to 1,800 mm
Margin specifications		No margin
Printing width settings input units		0.1 mm

Power

Item	Specifications	Notes
Voltage	400 V \pm 10%, 3-phase + Neutral + Earth	
Frequency	50/60 Hz \pm 3%	
Rated current	30 A or less	Includes internal heater 20 A
Power consumption	20.7 KVA	
Rated short-circuit current	1.5 kA	
Leakage current	300 mA or less	
Factory facilities Connected/Wired	Compatible crimped terminals: M8 Live wire (3-phase + Neutral) M5 Earth wire (Earth) Wiring specifications (recommended): Withstand voltage of 600 V (UL1063 equivalent) Wire size of 10 mm ² or larger	

Factory facilities

Item	Specifications	Notes
Electrical power	Refer to "Power" on page 315 .	
Pressurized air	Connector: ϕ 8 mm (outer diameter) Pressure: 0.6 MPa (6 bar) Flow rate: 3,550 Liter/hr	Required for raising/lowering the cleaning tank, ink pressure, etc. Please provide the compressed air required for externally connected devices, such as a feeding unit.
Water	Connector: 3/4 gas Pressure: Min 0.4 MPa (4 bar) Flow rate: Max 300 Liter/hr	Required for belt cleaning. Flow rate with 100% ink duty
Wastewater	Pipe: Applicable outer pipe diameter: ϕ 48 mm Applicable pipe diameter: 40 A	Required for wastewater for belt cleaning. Users are requested to dispose of wastewater according to local laws and regulations.
Waste ink	Connector: Three hoses with minimum ϕ 12 mm	Waste ink is discharged from a total of three locations (two on the Home side and one on the Full side). Users are requested to dispose of waste ink according to local laws and regulations.

Item	Specifications	Notes
Exhaust	Connector: \varnothing 125 mm Pipe length: 10 m Flow rate: 1,200 m ³ /hr	Required for mist exhaust in the machine. If connection with factory exhaust is not possible, please provide a mist exhaust fan.
Network	A communication speed of 100BASE-TX or more is recommended.	Please provide a network environment to which the control PC can be connected.

Supported Ink

The list of supported inks below may not be up-to-date. When making a purchase, check the latest inks at your distributor.

Acidic

Color Name	Color Code
Black	BK
Cyan	C
Magenta	M
Yellow	Y
Grey	GY
Red	R
Blue	BL
Cobalt	CO
Orange-F	OR-F
Rubine	RB
Fluorescent Pink	FP
Fluorescent Flavine	FL

Reactive

Color Name	Color Code
Black	BK
Cyan	C
Magenta	M
Yellow	Y
Grey	GY
Red	R
Blue	BL
Orange	OR
Crimson	CR
Grey (GOTS) ^{*1}	GY-G

Disperse

Color Name	Color Code
Black	BK
Cyan	C
Magenta	M
Yellow	Y
Grey	GY
Red	R
Blue	BL
Orange	OR

Pigment

Color Name	Color Code
Black	BK
Cyan	C
Magenta	M
Yellow	Y
Yellow-C	Y
Grey	GY
Red	R
Green	GR
Orange	OR

Other

Color Name	Color Code
Ink Penetration Liquid (Acid ink, reactive ink) ^{*2}	AC
Ink Penetration Liquid (Disperse ink) ^{*2}	AC

*1: GOTS: Global Organic Textile Standard

*2: Do not use the color (column) next to the ink penetration liquid in the same head. The discharge of ink penetration liquid may become unstable. Ink is not discharged if the check is removed from [Belt Speed Volume Switch] on the [Setting] tab. Contact your dealer or Epson Support for details.

Ink Cartridges

Item	Specifications
Ink Type	"Supported Ink" on page 317
External dimensions	Width (W): 150 mm Length (D): 235 mm Height (H): 412 mm
Weight	Approx. 12 kg
Ink color	"Supported Ink" on page 317
Operating environment conditions	<p>(1) Temperature: "Basic Specifications" on page 313</p> <p>(2) Relative humidity: "Basic Specifications" on page 313</p> <p>(3) The ink in a cartridge will freeze if left in an environment whose temperature is -10°C or less. If ink is frozen, thaw it at room temperature and then use the ink after it is within the operating temperature range.</p> <p>Reference: In a 25°C environment it takes approximately 34 hours for frozen ink to warm from -10°C to 20°C. In a 25°C environment it takes approximately 18 hours for ink to warm from 10°C to 20°C.</p>
Warranty period during storage and transport	"Basic Specifications" on page 313
Transport and storage environment	<p>(1) Temperature: 10 to 35°C (recommended warranty temperature)</p> <p>(2) Relative humidity: 35 to 85% (no condensation)</p>
Recommended lifetime	Indicated on ink cartridge labels
Orientation during transport and storage	<p>During transport and storage, ink cartridges should be placed with the side of the box displaying the shaking procedure explanation facing down.</p> 
Stack height during transport and storage	6 ink cartridges high

* The expiration date is indicated on the ink cartridge box.

Consumables

The list of consumables below may not be up-to-date. When making a purchase, check the latest consumables at your distributor.

Product Name	Model No.	Use
Mist filter	C13S210133	Mist filter replacement parts
Blower filter	C13S210134	Blower filter replacement parts
Washing scraper	C13S210132	Washing T-shaped scraper replacement parts
Washing silicone scraper (Soft type)	C13S210159	Washing silicone scraper replacement parts
Wiper (Large)	C13S210168	Wiper replacement parts
Cap	C13S210157	Cap unit replacement parts
Pump Tube	C13S210169	Ink tube replacement parts
Cooling fan filter (Large)	C13S210170	Cooling fan filter replacement parts
Clean Stick B	C13S090011	Cap and wiper cleaning
Head Cleaning Cloth A	C13S210050	Head cleaning
Maintenance Liquid	C13T42X000	Wetted parts cleaning
Cleaning Liquid	C13T49Q010	For cleaning before initial charging Use it after the ink replacement
Nozzle cleaning brush (nozzle clogging recovery jig)	C13S400214	Use to clean the nozzle surfaces.

Options

The list of options below may not be up-to-date. When making a purchase, check the latest options at your distributor.

Product Name	Model No.	Use
Feeding unit	C12C937761	Unit where the fabric roll is installed which feeds the fabric into the machine
2 inch feeding spindle	C12C939721	Feeding spindle for paper core with a 2-inch inner diameter (for feeding unit)
3 inch feeding spindle	C12C939731	Feeding spindle for paper core with a 3-inch inner diameter (for feeding unit)
Glue blocks (blocks for applying glue)	C12C938661	For glue application
Glue bucket (glue collection bucket)	C12C938681	For glue removal



Appendix

Screen Reference

This appendix describes the screens on the control PC.

Main Screen

The main screen is described below.

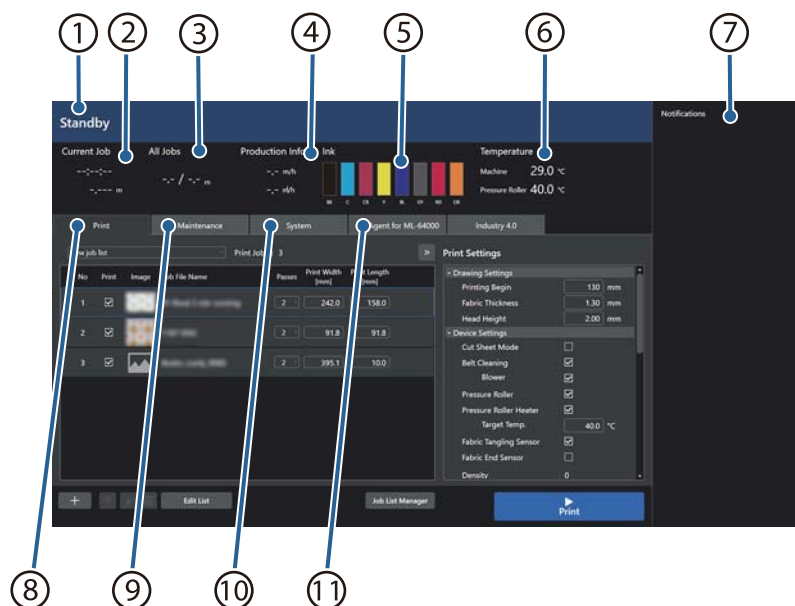

No.	Name	Description
1	Status	Displays the status of the machine.
2	Current Job	Displays the print time and printed length for the Rob file (job) currently being printed or the Rob file (job) last printed.
3	All Jobs	Displays the printed length for the job list currently being printed.
4	Production Info	Displays the print speed (length and area printed per hour).
5	Ink	Displays the ink level.
6	Temperature	Displays temperature information.
7	Notifications	Displays notification information sent from the machine.
8	Print	Displays the [Print] menu. (Page 325)
9	Maintenance	Displays the [Maintenance] menu. (Page 332)
10	System	Displays the [System] menu. (Page 333)
11	DC Agent for ML-64000	Displays the [DC Agent for ML-64000] menu. (Page 335)

Ink

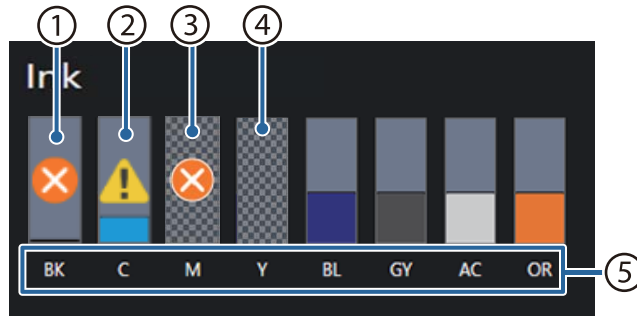

No.	Screen	Description
1		Ink is expended. Replace the old ink cartridge with a new one.
2		Indicates that little ink remains. Ready a new ink cartridge.
3		Indicates an ink cartridge error. Confirm the status of the ink cartridge.
4		The ink level could not be acquired immediately after starting the control PC.
5	Color Code	Displays the ink color. For more information about ink color and ink type, refer to [System]-[Ink].

Temperature

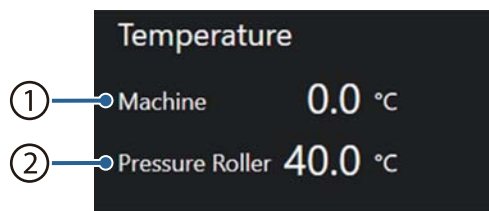



No.	Name	Description
1	Machine	Temperature inside the machine.
2	Pressure Roller	Temperature of the pressure roller.

Printing

The [Print] menu is described below.



No.	Name	Description
1	New job list	Select a job list.
2	Job list	Displays a list of the jobs (Rob files) that are registered in the job list. For more information, refer to "Job Setting Menu" on page 326 .
3	[Add Job] screen display	Adds a job. Press  to display the [Add Job] screen.
4	Edit	The Edit Job List screen is displayed.
5	Job List Manager	Displays the [Job List Manager] screen.
6	Show/hide the [Print Settings] screen	Sets whether to show/hide the [Print Settings] screen.  : Displays the [Print Settings] screen.  : Hides the [Print Settings] screen.
7	Print Job(s)	Displays the number of print jobs.

Job Setting Menu



No.	Name	Description
1	No.	Number of the Rob file.
2	Print	Select the Rob file to print. Select this box to print the file.
3	Image	Displays the thumbnail for the Rob file. Click a thumbnail to display the detailed information for the job.
4	Rob File Name	File name of the Rob file.
5	Resolution	Resolution of the Rob file. W x H [Units: dpi]
6	Passes	Select the number of passes for printing. Consider the print quality and productivity when setting the number of passes.
7	Print Width	Width to be printed. [Units: mm] Setting value: 10.0 to 1824.0
8	Print Length	Length to be printed. [Units: mm] Setting value: 10.0 to 9999000.0
9	Repeat	Sets the number of times to repeat the job printing. If this is set, job printing is repeated including the job pitch. Setting value: 1 to 999 This is displayed when [Print Settings] is hidden.
10	Bidirectional Printing	Specify the printing direction. Select this check box to enable bidirectional printing. This is displayed when [Print Settings] is hidden.
11	Pause	Sets whether to enable/disable pausing. Select this check box to enable this setting. This is displayed when [Print Settings] is hidden.
12	Draw Cut	Sets whether to enable/disable the draw cut. Select this check box to enable this setting. This is displayed when [Print Settings] is hidden.

No.	Name	Description
13	Job Pitch	<p>Sets the interval until the next job.</p> <p>This is enabled when the following settings are the same with the next job.</p> <ul style="list-style-type: none">• Resolution• Number of passes• Bidirectional Printing• Advanced Quality <p>(For more information, refer to "Job Details Information" on page 328)</p> <p>When there are consecutive jobs with the same settings, they will be consolidated and treated as a single job.</p> <p>If the settings are different, you cannot print seamlessly (margin: 0 mm) with the next job. An interval of up to one head section plus the interval set here will be the interval to the next job.</p> <p>This is displayed when [Print Settings] is hidden.</p>

Job Details Information

This can be viewed by clicking the thumbnail or file name in the Job Settings menu.

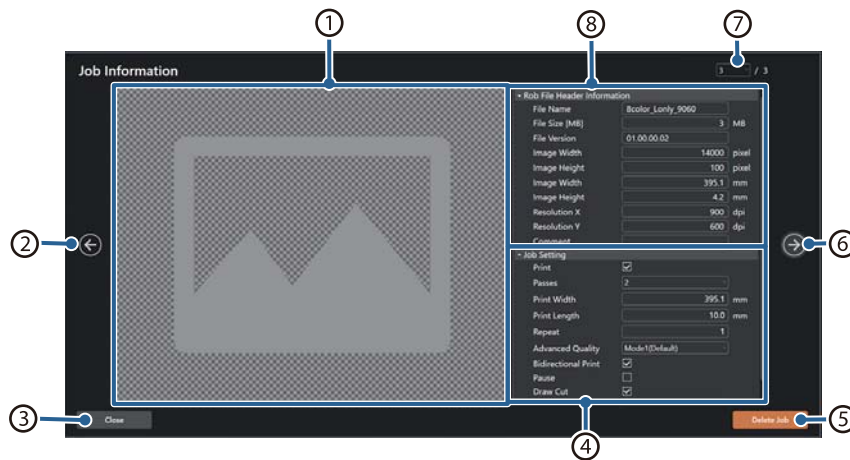

No.	Name	Description
1	Image	Displays the thumbnail for the Rob file.
2	Switch job button (Prev)	Displays the Job Details information for the previous job in the job list.
3	Close button	Click to close the Job Details screen.
4	Job Setting menu	<p>For more information, refer to "Job Setting Menu" on page 326.</p> <ul style="list-style-type: none"> Advanced Quality: If there is uneven penetration or stripes at the head seams that cannot be resolved even after implementing print adjustments, selecting the modes below may reduce the stripes and unevenness. <ul style="list-style-type: none"> Mode1: Default Mode2: When the stripe width is 5 mm Mode3: When the stripe width is 1 mm
5	Delete Job	Deletes the displayed job.
6	Switch job button (Next)	Displays the Job Details information for the next job in the job list.
7	Select Job	Specify a job number to display the Job Details information for that job.
8	Rob File Header Information	<p>Displays the Rob file header information.</p> <p>For more information, refer to "Job Setting Menu" on page 326.</p>

Print Settings

Configures the print settings for a job. Click [<<] to display this.

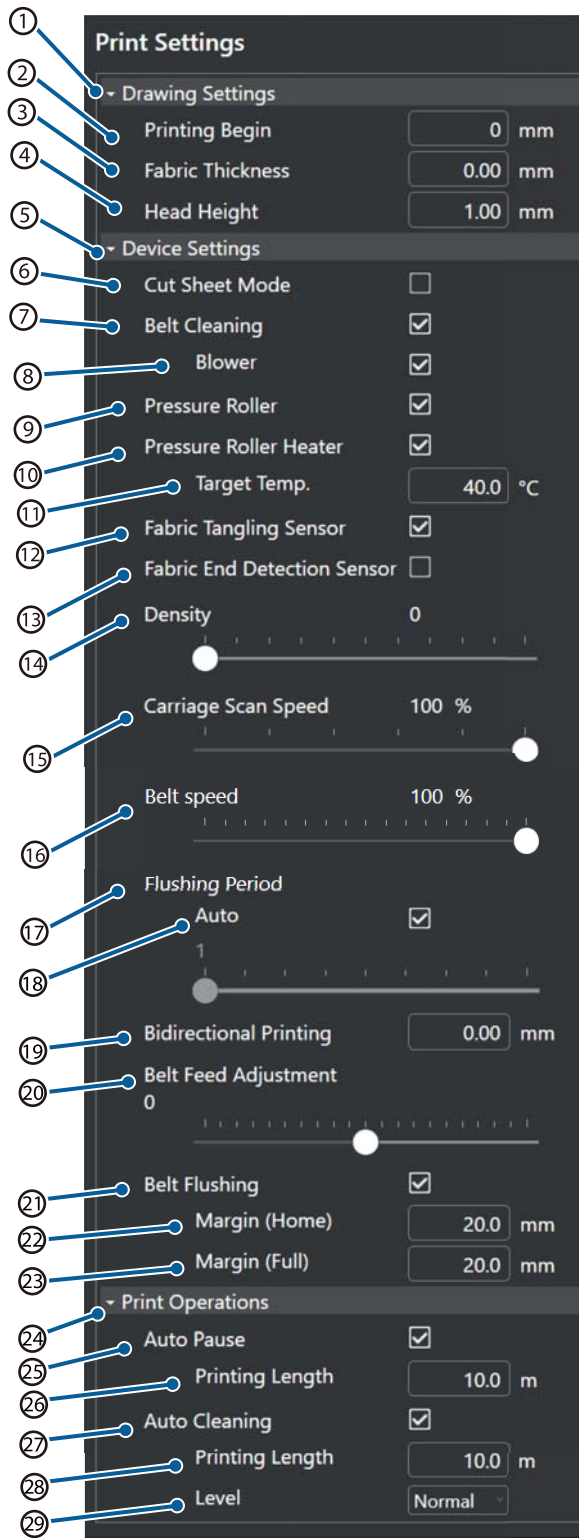

No.	Name	Description
1	Drawing Settings	Configures Printing Begin, Fabric Thickness, and other settings.

No.	Name	Description
2	Printing Begin	Sets the print start position for ROB file printing. Setting value: 0 to 1569 mm
3	Fabric Thickness	Set the fabric thickness. If the fabric does not have a consistent height, such as for shaggy fabric, enter the average value. Setting value: 0 to 10 mm
4	Head Height	Set the print head height. Setting value: 0 to 10 mm
5	Device Settings	Configures settings related to printing for this machine.
6	Cut Sheet Mode	Cut Sheet Mode. Select this check box to enable this setting.
7	Belt Cleaning	Select this to perform belt cleaning while the feed button is held. This is disabled if Cut Sheet Mode is selected.
8	Blower	After belt cleaning is complete, a blower is used to remove water droplets. Select this check box to enable the blower. This is disabled if Cut Sheet Mode is selected.
9	Pressure Roller	Select this to push on the fabric or cut sheets while the feed button is held.
10	Pressure Roller Heater	The pressure roller heater. Select this check box to enable this setting.
11	Target Temp.	Set the temperature for the pressure roller heater. This is disabled if Pressure Roller Heater is not selected. Setting value: 20 to 60°C There is no cooling function for the pressure roller. If the ambient temperature around the machine is 20°C or higher, the pressure roller will not be lower than that temperature.
12	Fabric Tangling Sensor	Sets the tangled fabric detection sensor. Select this check box to enable this setting.
13	Fabric End Detection Sensor	Detects the fabric end. A message is displayed if printing starts with this check removed.
14	Density	Set the print density. Setting value: 0 to 10
15	Carriage Scan Speed	Set the speed of the print head. Setting value: 50 to 100%
16	Belt Speed	Set the speed of the belt. Setting value: 20 to 100%
17	Flushing Period	Set the frequency for flushing. Setting value: 1 to 9
18	Auto	Automatically performs flushing during printing. Select this check box to enable this setting. A message is displayed if printing starts with this check removed.

No.	Name	Description
19	Bidirectional Printing	If you unselect this check box, one-directional printing is selected, and printing is performed only when the print head moves in a certain direction. The print quality is improved, but print speed falls below normal. If ruled lines are misaligned or unevenness occurs, selecting one-directional printing may improve the symptoms. Setting value: -2.0 to 2.0
20	Belt Feed Adjustment	Adjusts the belt feed amount. Setting value: -10 to 10
21	Belt Flushing	Sets flushing. Select this check box to enable this setting. This is disabled if Cut Sheet Mode is selected. If Belt Flushing is enabled, automatic nozzle checking is not performed during printing. If you want to perform an automatic nozzle check while printing with Belt Flushing enabled, pause printing and press the [Maintenance] menu - [Auto Nozzle Check] tab - [Start]. For more information on pausing printing, refer to "Emergency Stop and Pause" on page 20 .
22	Margin (Home)	Sets the margin for flushing on the home side. Select this check box to enable this setting. This is disabled if Belt Flushing is not selected.
23	Margin (Full)	Sets the margin for flushing on the full side. Select this check box to enable this setting. This is disabled if Belt Flushing is not selected.
24	Print Operations	Configures the settings for when printing automatically.
25	Auto Pause	Sets the machine to pause after the specified length has been printed. Select this check box to enable this setting.
26	Printing Length (Auto Pause)	Sets the length for the machine to pause after the specified length has been printed. Setting value: 0.1 to 999.9 m
27	Auto Cleaning	Sets the machine to perform cleaning after the specified length has been printed. Select this check box to enable this setting.
28	Printing Length (Auto Cleaning)	Sets the length for the machine to perform cleaning after the specified length has been printed. Setting value: 0.1 to 999.9 m
29	Level	Sets the strength for the machine to perform cleaning after the specified length has been printed. Adjust the Level setting as necessary.

Maintenance

The [Maintenance] menu is described below.

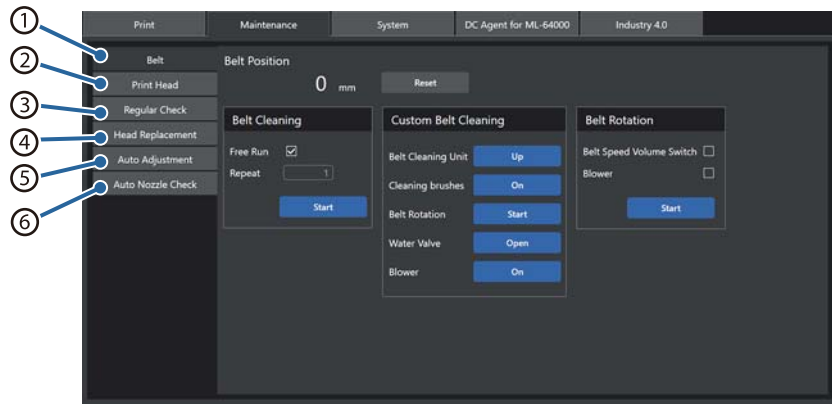

No.	Name	Description
1	Belt	Displays the [Belt] tab. Configures the settings related to belt cleaning.
2	Print Head	Displays the [Print Head] tab. Configures the settings related to heads.
3	Regular Check	Displays the [Regular Check] tab. Moves the heads and locks/unlocks the side doors during maintenance.
4	Head Replacement	Displays the [Head Replacement] tab. Configures settings related to print head replacement.
5	Auto Adjustment	Displays the [Auto Adjustment] tab. Performs camera calibration, automatic density adjustment, and automatic X offset adjustment.
6	Auto Nozzle Check	Displays [Auto Nozzle Check]. Automatically inspects whether any nozzles are clogged. If Belt Flushing is enabled, automatic nozzle checking is not performed during printing. If you want to perform an automatic nozzle check while printing with Belt Flushing enabled, pause printing and press the [Auto Nozzle Check] tab - [Start]. For more information on pausing printing, refer to "Emergency Stop and Pause" on page 20.

System

The [System] menu is described below.

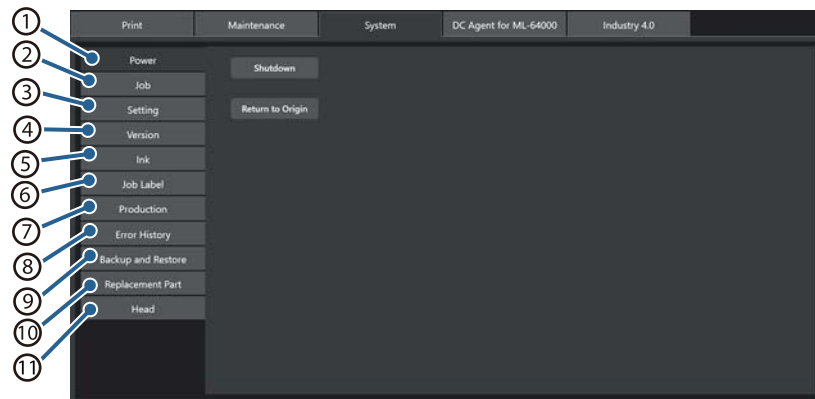

No.	Name	Description
1	Power	Displays the [Power] tab. Turns the power off and returns to the origin.
2	Job	Displays the [Job] tab. Configures settings related to print jobs.
3	Setting	Displays the [Setting] tab. Configures detailed head settings.
4	Version	Displays the [Version] tab. Displays the version of the machine's firmware.
5	Ink	Displays the [Ink] tab. Shows information about the ink installed in the machine.
6	Job Label	Displays the [Job Label] tab. This function adds information such as the settings for printing to the print data for each job file and prints said information.
7	Production	Displays the [Production] tab. Displays the print information for data printed in the past.
8	Error History	Displays the [Error History] tab. Displays the history of error information for this machine.
9	Backup and Restore	Displays the [Backup and Restore] tab. This can create a backup for basic settings and adjustment values you have set. If you create a backup, you can select the basic settings and adjustments you want to restore and then restore them.
10	Replacement Part	Displays the [Replacement Part] tab. Displays the usage for general parts, pump parts, and wiper parts, and registers the day a part was replaced.
11	Head	Displays the [Head] tab. Selects whether to use 64 print heads or 32 print heads.

Checking the Print Settings of Data Printed in the Past

Press the [System] menu, and then the [Production] tab. Select a date to display a list of print times and data. Then, select the desired print data to display its print settings.

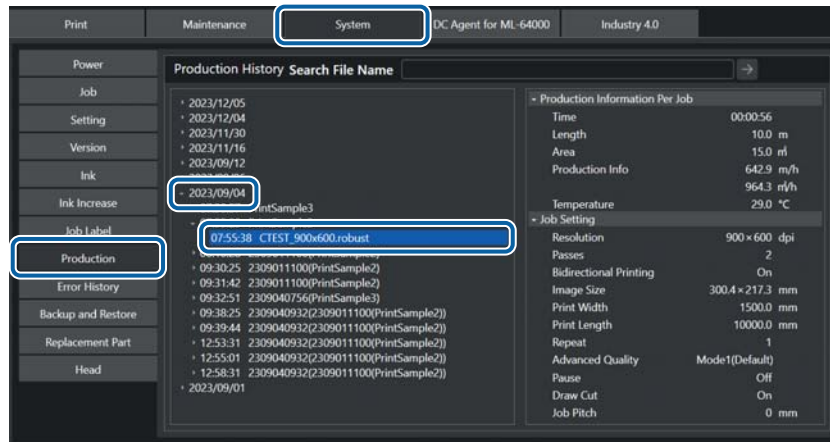

Enter a partial file name for the print data in the [Search by File Name] field and press [→] to display a list of print data.

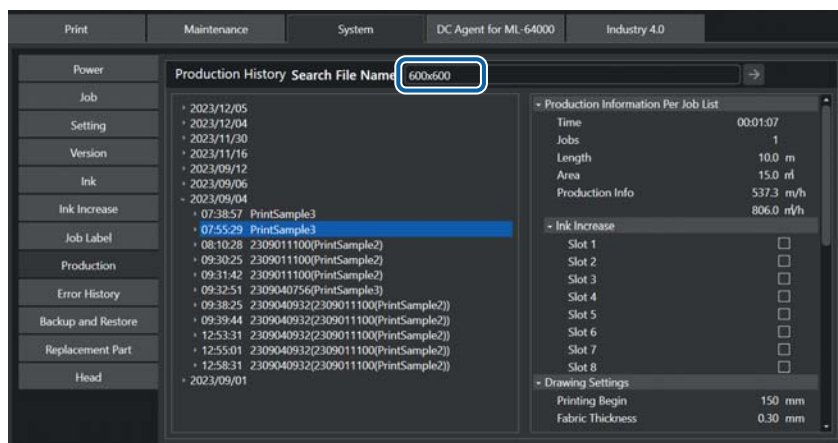

Click the name of the print data to view its print settings.

DC Agent for ML-64000

The [DC Agent for ML-64000] menu is described below.

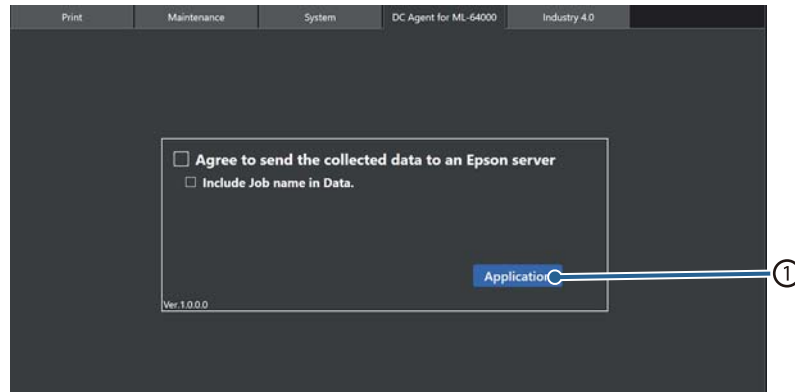

No.	Name	Description
1	Apply	Click to send the machine status and information to "Epson Cloud Solution PORT".

Job List Manager

This displays the registered job lists.

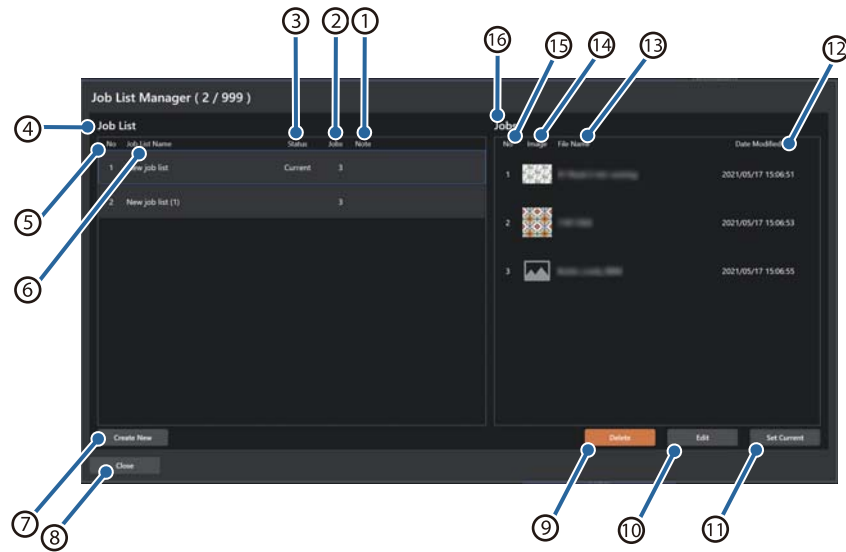

No.	Name	Description
1	Note	Displays the comment for the job list.
2	Jobs	Displays the number of registered jobs.
3	Status	Displays the status of the job list. Current: Indicates the selected job list.
4	Job List	Displays the registered job lists.
5	No	Displays the job list number.
6	Job List Name	Displays the job list name.
7	Create New	Creates a new job list.
8	Close	Closes the Job List Manager screen.
9	Delete	Deletes the selected job list.
10	Edit	Displays the edit screen for the selected job list. You can register and delete jobs.
11	Set Current	Displays the screen for selecting a job list.
12	Date Modified	Displays the date and time a job file was modified.
13	File Name	Displays the job file name.
14	Image	Displays the image for the job.
15	No	Displays the job number.
16	Jobs	Displays the jobs that are registered in the job list.